



**Western Cape
Government**

Education

**Directorate Curriculum:
FET SCHOOLS**

**WESTERN CAPE EDUCATION
DEPARTMENT**

GRADE 12

MATHEMATICAL LITERACY

ASSIGNMENT 1

TERM 1

MARKS: 70

TIME: 2 hours

INSTRUCTIONS

1. This assignment consists of 3 questions and an annexure
2. Answer All the questions, showing ALL calculations where necessary
3. Write neatly and legibly

The rapid decline of the rhino population is due to poaching. SAN parks issued a press release detailing the latest poaching statistics throughout the country between 2010 and 2012.



The table below shows the latest statistics in South Africa for rhino poaching.

QUESTION 1**TABLE 1: Rhino poaching statistics in SA from 2010 - 2012**

South Africa	2010	2011	2012
Kruger National Park (KNP)	146	252	137
Marakele National Park (MNP)	0	6	3
Gauteng(GP)	15	9	0
Limpopo (LIM)	52	74	34
Mpumalanga(MP)	17	31	8
North West (NW)	57	21	24
Eastern Cape (EC)	4	11	3
Free State (FS)	3	4	0
KwaZulu-Natal (KZN)	38	34	25
Western Cape (WC)	0	6	1
Northern Cape (NC)	1	0	0
TOTAL	333	448	235

(SOURCE: <http://www.wildernessfoundation.co.za>)

1.1.1 Calculate the following measures of central tendency for the 2012 poaching statistics:

- | | | |
|-----|--------|-----|
| (a) | mode | (2) |
| (b) | median | (2) |
| (c) | mean | (2) |

- 1.1.2 Which one of the 3 measures of central tendency would you use to represent the 2012 poaching statistics? Justify your choice. (3)
- 1.1.3 A national newspaper reported that rhino poaching in South Africa decreased by 50% between 2011 and 2012. Is the newspaper report correct? Justify showing all calculations. (3)
- 1.2.1 Calculate the following for the 2011 poaching statistics:
- the range (2)
 - first, second and third quartile value (Q1, Q2 and Q3) (4)
 - the inter-quartile range (3)
- 1.2.2 Compare the range and the inter-quartile range for 2011. (2)
- [24]**

QUESTION 2

Mr Sonn is a grade 12 Mathematical Literacy teacher at Commodore High School. He teaches 3 grade 12 classes:

- 12A: 17 learners,
- 12B: 16 learners and
- 12C: 15 learners

The June examination results of the 3 classes are represented by the box-and-whisker plots below:

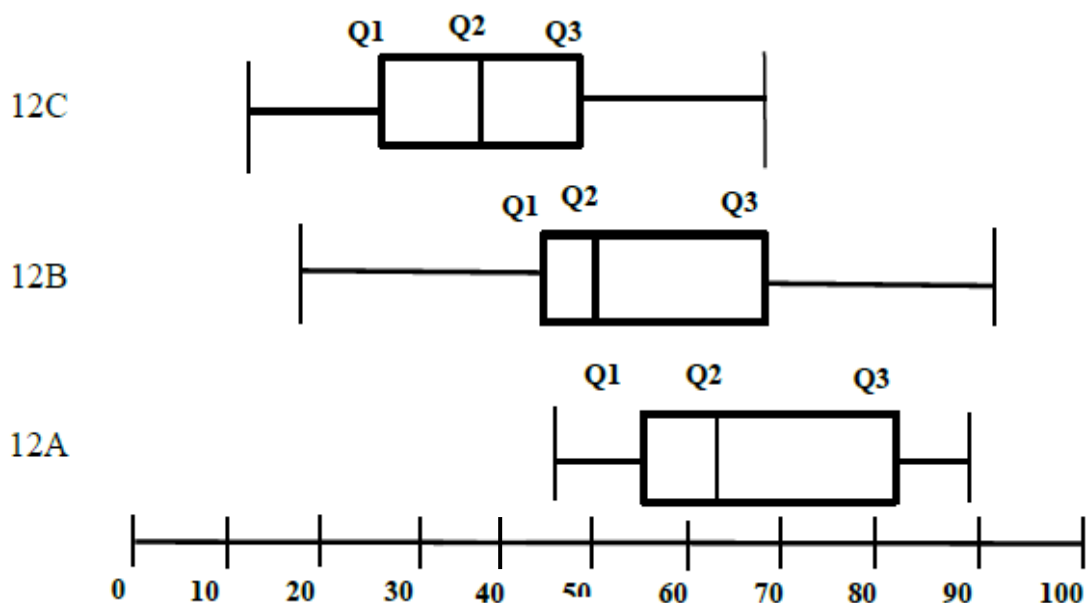

- 2.1 Estimate the median for 12C. (2)
- 2.2 Which of the three classes had the best examination performance? Explain your choice. (4)
- 2.3 From which class is the top learner? (2)

- 2.4 Learners whose scores are below 40% have failed the examination. Which class had the highest number of failures? (2)
- 2.5 Comment on 12C's performance, using the spread of marks as shown in the box-and – whisker plot for this class. (2)
- 2.6

The curriculum advisor asked Mr Sonn to identify learners for the winter school program organised by the district. All learners who scored 50% or less in the examination must attend. Learners who scored between 50% and 80% will have winter school classes at the school with their teacher. All learners who scored 80% or more will receive revision packs to work on their own in the comfort of their homes.
--
- 2.6.1 From which class will the least number of learners go to the district winter school? (2)
- 2.6.2 How many learners will receive revision packs? (6)
- 2.6.3 Which class will have the largest number of learners remaining with Mr Sonn during the winter school holiday? (2)
- [22]**

QUESTION 3

A growth chart is given to a mother at the birth of a baby to monitor the growth rate of her child. A growth chart for boys (birth to 36 months) is given on ANNEXURE A. Refer to the growth chart on ANNEXURE A to answer the following questions.

- 3.1 Determine the following percentiles and explain what each answer means:
- 3.1.1 a 3 year old boy who weighs 12kg (4)
- 3.1.2 a 15 month old boy with a length of 81 cm (4)
- 3.2 What will the length of a 27 month old boy be at the 10th percentile? (2)
- 3.3 What will the weight of a 21 month old boy be if the boy's weight falls at the 75th percentile? (2)
- 3.4 A baby weighs 3,6kg at birth and 9,8kg after a year and a half. Determine whether this child grows at a healthy rate. Explain your answer. (2)
- 3.5 Which measure of central tendency is represented by the 50th percentile? (2)
- 3.6 Timothy was born on 20 February 2011 and weighed 3.4 kg at birth. He was weighed at the clinic every three months thereafter. Draw a scatter plot of Timothy's weight-for-age from birth to 36 months on the growth chart on ANNEXURE A, using the table given on the growth chart (in the bottom right – hand corner). (4)

- 3.7 Timothy's weight dropped between the 18th and 21st months. Give one possible reason for the drop in his weight over this period. (2)

GRAND TOTAL: [24]
70

ANNEXURE A



**Western Cape
Government**

Education

**Directorate Curriculum:
FET SCHOOLS**

**WESTERN CAPE EDUCATION
DEPARTMENT**

GRADE 12

MATHEMATICAL LITERACY

ASSIGNMENT 1

TERM 1

MEMORANDUM

MARKS: 70

QUESTION 1

QUESTIONS	SOLUTION	EXPLANATION	MARK
1.1.1 (a)	0 ✓✓	2A answer	2
(b)	0 0 0 1 3 3 8 24 25 34 13 ✓ Median (Q2) = 3 ✓	1M order 1A answer	2
(c)	Mean = $\frac{0+0+0+1+3+3+8+24+25+34+137}{11}$ ✓ = 21,3636..... = 21,37 ✓	1M addition 1M dividing by 11 1CA answer	3
1.1.2	Mean ✓ It gives a better reflection of the seriousness of the situation. ✓✓	1A answer 2J reason	3
1.1.3	% decrease between 2011 and 2012: $\frac{448 - 245}{448} \times 100 = 45,31$ ✓✓ The newspaper report is incorrect. ✓	2 % decrease 1 conclusion	3
1.2.1 (a)	Range = max value – min value = 252 – 0 ✓ = 252 ✓	1M method 1A answer	2
(b)	0, 4, 6, 6, 9, 11, 21, 31, 34, 75, 252 ✓ Q1 = 6 ✓ Q2 = 11 ✓ Q3 = 34 ✓	1A order 1A Q1 1A Q2 1A Q3	4
(c)	Interquartile range (IQR) = Q3 – Q1 ✓ = 34 – 6 ✓ = 28 ✓	1M method 1CA values 1CA answer	3

1.2.2	The difference between the range and the IQR is very big ($218 = 252 - 28$). ✓ ✓ This is the result of an extreme outlier (252).	2A any suitable answer	2
			[24]

QUESTION 2

QUESTIONS	SOLUTION	EXPLANATION	MARK
2.1	38 ✓✓	2A answer	2
2.2	12A ✓✓ 50% of the learners achieved more than 60% ✓✓ or 50% of the learners achieved between 50% and 80%	2A answer 2J any suitable answer	4
2.3	12B ✓✓	2A answer	2
2.4	12C ✓✓	2A answer	2
2.5	75% of learners scored below 50% ✓✓ or 50% of learners scored higher than 38% or 25% of learners scored lower than 28% or	2A answer	2
2.6 2.6.1	12A ✓	2A answer	2
2.6.2	12A: 25% of 17 learners ✓ = 4,5 ✓ = 4 learner ✓ 12B: 12,5% of 16 learners ✓ = 2 learners ✓ 12C: = 0 Therefore, 6 learners will receive revision packs. ✓	1Mcorrect % 1A answer 1R rounding 1Mcorrect % 1A answer 1CA final answer	6
2.6.3	12A ✓	2A answer	2
			[22]

QUESTION 3

QUESTIONS	SOLUTION	EXPLANATION	MARK
3.1.1	5 th percentile ✓✓ 95% of three year old boys weigh more than him (12kg) ✓✓ or 5% of three year old boys weigh less than him	2A answer 2J any suitable answer	4
3.1.2	75th percentile ✓✓ 25% of three year old boys are taller than him (81cm) ✓✓ or 75% of three year old boys are shorter than him	2A answer 2J any suitable answer	4
3.2	85cm ✓✓	2A answer	2
3.3	13,2kg ✓✓	2A answer	2
3.4	3,6kg is on the 50th percentile. ✓ 9,8kg is on the 5th percentile. ✓ The baby is not growing at a healthy rate, because his growth rate should stay on or close to the 50th percentile throughout. ✓✓	1RG reading from chart 1RG reading from chart 2J any suitable answer	4
3.5	Median ✓✓	2A answer	2
3.6	Refer to next page for the answer	4A 1mark for every 2 points plotted	4
3.7	Timothy might have been ill during this period. (learners can mention the type of illness, like diarrhoea etc.) ✓✓	2A answer	2
			[24]
GRAND TOTAL:			70

