



# basic education

---

Department:  
Basic Education  
**REPUBLIC OF SOUTH AFRICA**

**SENIOR CERTIFICATE/  
NATIONAL SENIOR CERTIFICATE**

**GRADE 12**

**CONSUMER STUDIES**

**NOVEMBER 2020**

**MARKS: 200**

**TIME: 3 hours**

**This question paper consists of 17 pages.**

**INSTRUCTIONS AND INFORMATION**

1. This question paper consists of SIX questions.

<b>QUESTION</b>	<b>CONTENT</b>	<b>MARKS</b>	<b>TIME (minutes)</b>
1	Short Questions (All topics)	40	20
2	The Consumer	20	20
3	Food and Nutrition	40	40
4	Clothing	20	20
5	Housing and Interior	40	40
6	Entrepreneurship	40	40
<b>TOTAL:</b>		<b>200</b>	<b>180</b>

2. ALL the questions are **COMPULSORY** and must be answered in the **ANSWER BOOK**.
3. Number the answers correctly according to the numbering system used in this question paper.
4. Start **EACH** question on a **NEW** page.
5. You may use a calculator.
6. Write only in black or blue ink.
7. Pay attention to spelling and sentence construction.
8. Write neatly and legibly.

**QUESTION 1: SHORT QUESTIONS**

- 1.1 Various options are provided as possible answers to the following questions. Choose the answer and write only the letter (A–D) next to the question numbers (1.1.1 to 1.1.20) in the ANSWER BOOK, e.g. 1.1.21 D.
- 1.1.1 The money charged by the bank when borrowing money:
- A Bond
  - B Loan
  - C Interest
  - D Rates
- (1)
- 1.1.2 Choose the CORRECT statement regarding the use of gas appliances in the home:
- A It is safer to use gas than electricity.
  - B Gas is a renewable source of energy.
  - C Gas appliances cost more to maintain.
  - D Gas is more environmentally friendly than electricity.
- (1)
- 1.1.3 Electricity can be saved by using ...
- A a stove plate bigger than the saucepan.
  - B the same size saucepan as the stove plate.
  - C a preheated saucepan.
  - D the highest temperature setting of the stove plate.
- (1)
- 1.1.4 The following tax payers pay provisional tax:
- A Farmers and nurses
  - B Sole traders and administration clerks
  - C Business owners and farmers
  - D Sole traders and nurses
- (1)
- 1.1.5 A ... allows all its members to benefit from it.
- A scam
  - B stokvel
  - C chain letter
  - D pyramid scheme
- (1)
- 1.1.6 The diet of a person with gluten intolerance should include ...
- A yoghurt and white bread.
  - B yoghurt and rye bread.
  - C fruit salad and whole-wheat bread.
  - D fruit salad and potato bread.
- (1)

- 1.1.7 A diet rich in iron may help with the management of ...  
 A osteoporosis.  
 B anaemia.  
 C hypertension.  
 D diabetes. (1)
- 1.1.8 The nutrition-related health condition that is classified as type 1 and type 2:  
 A Arteriosclerosis  
 B Hypoglycaemia  
 C Hyperglycaemia  
 D Diabetes (1)
- 1.1.9 Food additives that will improve the taste of food:  
 A Monosodium glutamate (MSG) and antioxidants  
 B Antioxidants and aspartame  
 C Sweeteners and monosodium glutamate (MSG)  
 D Aspartame and lecithin (1)
- 1.1.10 Processed foods of which the bacterial load has been reduced or destroyed are ... foods.  
 A inorganic  
 B organic  
 C irradiated  
 D genetically modified (1)

<b>BACON/MACON</b>	<b>ENERGY (kJ)</b>	<b>PROTEINS (g)</b>	<b>SODIUM (mg)</b>	<b>SATURATED FAT (g)</b>
Bacon/macon 1	600	8,1	240	2,5
Bacon/macon 2	1 050	10,6	355	9,6
Bacon/macon 3	750	12	295	5,5
Bacon/macon 4	900	9,5	450	6,8

- 1.1.11 With reference to the table above, a person with hypertension should limit their intake of ...  
 A bacon/macon 1.  
 B bacon/macon 2.  
 C bacon/macon 3.  
 D bacon/macon 4. (1)
- 1.1.12 ... is an example of an eco-friendly fabric.  
 A Acrylic  
 B Hemp  
 C Nylon  
 D Polyester (1)

1.1.13 Study the picture below and answer the question that follow:



[Source: [stylecaster.com](http://stylecaster.com)]

The top is an example of a ...

- A fashion fad.
- B fashion trend.
- C standard trend.
- D classic fashion.

(1)

1.1.14 Which of the following logos is an example of brand piracy?

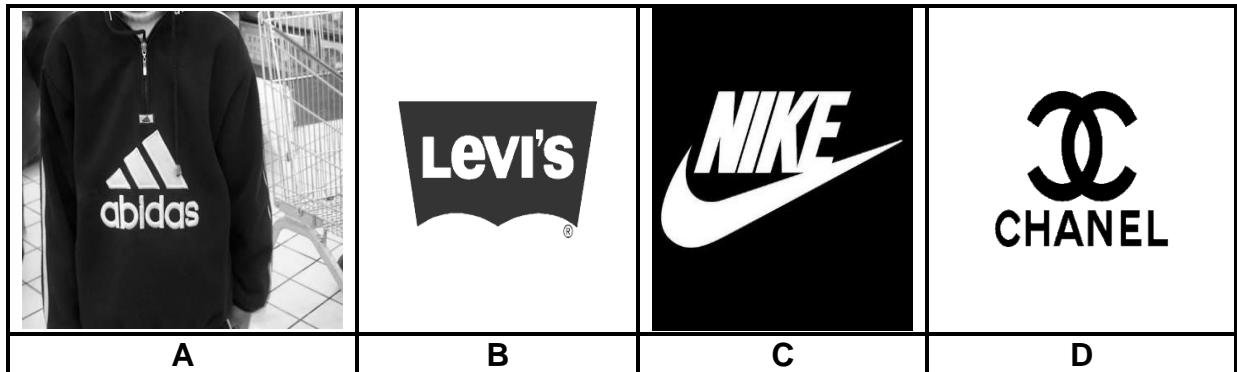

- A Logo A
- B Logo B
- C Logo C
- D Logo D

(1)

1.1.15 The levy paid by a sectional-title home owner is used for ...

- A household insurance and maintenance of gardens.
- B security and painting of the barrier walls.
- C water for each unit and general maintenance.
- D body cooperate salaries and property insurance.

(1)

- 1.1.16 A mortgage repayment may not exceed ... of the buyer's income.
- A 15% to 20%
  - B 25% to 30%
  - C 35% to 40%
  - D 45% to 50%
- (1)
- 1.1.17 ... covers the damage to the structure and fixtures of the house.
- A Household insurance
  - B Mortgage protection insurance
  - C Homeowner's comprehensive insurance
  - D Life assurance
- (1)
- 1.1.18 Product specification includes:
- A Size of the product
  - B Target market
  - C Human skills
  - D Time of production
- (1)
- 1.1.19 The purpose of staff training:
- A Hire new employees
  - B Conduct stock taking
  - C Increase productivity
  - D Attract the target market
- (1)
- 1.1.20 A business can reduce its carbon footprint by using ...
- A inorganic materials.
  - B local raw materials.
  - C plastic packaging.
  - D synthetic cleaning agents.
- (1)

1.2 Choose the stage in the fashion cycle in COLUMN B that matches the percentage of sales in a fashion cycle in COLUMN A. Write only the letter (A–E) next to the question numbers (1.2.1 to 1.2.3) in the ANSWER BOOK.

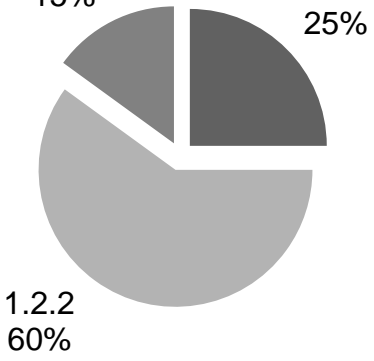
COLUMN A PERCENTAGE OF SALES	COLUMN B STAGES IN FASHION CYCLE
<p style="text-align: center;"><b>SALES</b></p>  <p>A pie chart titled 'SALES' is divided into three segments. The largest segment, representing 60% of sales, is labeled '1.2.2'. The second largest segment, representing 25% of sales, is labeled '1.2.1'. The smallest segment, representing 15% of sales, is labeled '1.2.3'.</p>	<p>A decline</p> <p>B standard</p> <p>C peak</p> <p>D obsolete</p> <p>E rise</p>

(3 x 1)

(3)

1.3 Choose THREE examples in COLUMN B that match the business costs in COLUMN A. Write only the letter (A–G) next to the question numbers (1.3.1 and 1.3.2) in the ANSWER BOOK.

COLUMN A BUSINESS COSTS	COLUMN B EXAMPLES
<p>1.3.1 Production costs</p> <p>1.3.2 Start-up costs</p>	<p>A registration fees</p> <p>B rent</p> <p>C stationery</p> <p>D staff holiday vouchers</p> <p>E business licence</p> <p>F equipment</p> <p>G water and electricity</p>

(3 x 2)

(6)

1.4 Identify SIX expenses in the list below that are payable when buying a townhouse in a new development. Write only the letters (A–L) next to the question number (1.4) in the ANSWER BOOK.

- A Connection fees
- B Labour costs
- C Initiation fees
- D Security fees
- E Administration fees
- F Renovation costs
- G Property rates
- H Estate agent fees
- I Conveyance fees
- J Transfer duty
- K Deeds office fees
- L Household insurance

(6)

1.5 Identify the food-borne disease in the list below characterised by the incubation periods. Write only the name of the food-borne disease next to the question numbers (1.5.1 to 1.5.5) in the ANSWER BOOK.

anaemia; bulimia; celiac disease; dysentery; E. coli; gastro-enteritis; hepatitis A; hypoglycaemia; lactose intolerance; tuberculosis
--

1.5.1 Three to five weeks/28 days

1.5.2 Two to 12 weeks/six weeks

1.5.3 One to three days

1.5.4 A few hours

1.5.5 Three to seven days

(5 x 1)

(5)  
[40]



**QUESTION 2: THE CONSUMER**

- 2.1 Name the body that is responsible for the increasing or decreasing of interest rates in South Africa. (1)
- 2.2 Identify the types of taxes payable on the following:
- 2.2.1 Liquor and cigarettes (1)
- 2.2.2 Petrol and diesel (1)
- 2.3 State TWO ways in which electricity can be saved when drying clothes. (2)
- 2.4 

Carol bought a television set from a shop that imports household appliances without the consent of the manufacturer.
[Own text]
- 2.4.1 Identify the type of import stated above. (1)
- 2.4.2 Discuss the type of import identified in QUESTION 2.4.1. (2)
- 2.5 Write a paragraph and discuss the negative effect of rising inflation on South African households. (6)
- 2.6 Study the information on SCHEME A and SCHEME B below and answer the questions that follow.

SCHEME A	SCHEME B
<ul style="list-style-type: none"> <li>• Recruits people</li> <li>• Recruiters earn more money</li> <li>• Buying and selling a product</li> <li>• Number of new recruits increases</li> <li>• Members do not lose money</li> <li>• Scheme continues</li> </ul>	<ul style="list-style-type: none"> <li>• Recruits people</li> <li>• Recruiters must recruit more people</li> <li>• Only money is invested</li> <li>• Number of new recruits is reduced</li> <li>• Members eventually lose money</li> <li>• Scheme collapses</li> </ul>

Redraw the table below in your ANSWER BOOK and complete the table with the following information:

	SCHEME A	SCHEME B
2.6.1	(1)	(1)
2.6.2	(2)	(2)

- 2.6.1 Name the TWO schemes above. (1 + 1) (2)
- 2.6.2 Differentiate between the TWO schemes in QUESTION 2.6.1. (2 + 2) (4)
- [20]**

**QUESTION 3: FOOD AND NUTRITION**

- 3.1 Name the soft, white, waxy, fatty substance that occurs naturally in the blood. (1)
- 3.2 Study the illustration below and answer the questions that follow.

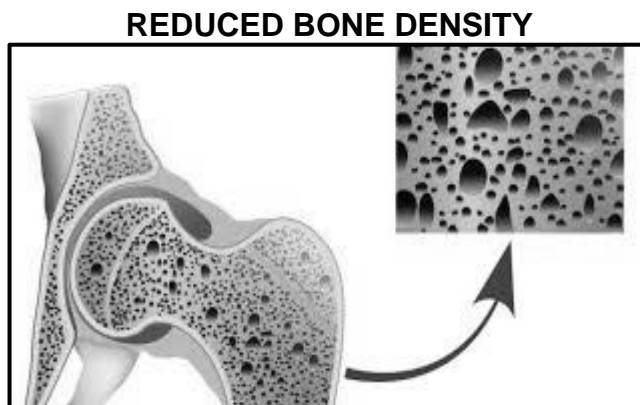

[Source: <https://www.eopcn.ca/seniors-health>]

- 3.2.1 Identify the food-related health condition above. (1)
- 3.2.2 Define the food-related health condition above. (2)
- 3.2.3 State FOUR factors that could contribute to the food-related health condition identified in QUESTION 3.2.1. (4)
- 3.3 Compare the eating disorders *anorexia nervosa* and *bulimia nervosa* with reference to the following aspects:

Redraw the table below in your ANSWER BOOK and complete the table with the following information:

	<b>ASPECT</b>	<b>ANOREXIA NERVOSA</b>	<b>BULIMIA NERVOSA</b>
3.3.1	Eating habits	(2)	(2)
3.3.2	Kilojoule intake	(1)	(1)

- 3.3.1 Eating habits (2 + 2) (4)
- 3.3.2 Kilojoule intake (1 + 1) (2)

3.4 A feeding scheme serves chicken and vegetable soup with brown bread to the local community every day. The soup consists of chicken, carrots and tomatoes.

[Own text]

Explain the nutritional benefits of the meal for a person with HIV/Aids. (5)

- 3.5 Discuss how genetically modified foods can assist with food security. (4 x 2) (8)
- 3.6 Study the label below and answer the questions that follow.

<b>LIGHT MEAT TUNA SHREDDED IN BRINE</b>		
<b>Nutritional information</b>		
<b>AVERAGE VALUES</b>	<b>PER 100 g</b>	<b>PER 80 g</b>
Energy	389 kJ	311 kJ
Protein	21,4 g	17,4 g
Carbohydrates	0 g	0 g
Total fat:	0,8 g	0,6 g
Saturated	0,2 g	0,2 g
Trans	0,0 g	0,0 g
Monounsaturated	0,1 g	0,1 g
Polyunsaturated	0,3 g	0,2 g
Cholesterol	54 mg	43 mg
Dietary fibre	0,5 g	0,5 g
Total sodium	360 mg	288 mg

Ingredients: Skipjack tuna, brine (water, salt), vegetable extract (peas, carrots)

Allergens: Fish



The logo features a stylized fish with a checkmark inside its body, set against a dark background. Above the fish, the text reads 'CERTIFIED SUSTAINABLE SEAFOOD' and 'MSC' in large letters, with 'www.msc.org' below it. A small 'TM' symbol is at the bottom right of the logo.

[Source: Pick n Pay Light Meat Tuna]

- 3.6.1 Explain why the word *allergens* appears on the label. (3)
- 3.6.2 Explain the meaning of the term *sustainable* on the label. (2)
- 3.6.3 The tuna is suitable for a person with high blood cholesterol.  
Evaluate the validity of this statement. (8)
- [40]**

**QUESTION 4: CLOTHING**

- 4.1 Define *retrospective fashion*. (2)
- 4.2 Many products bear the logo below.



[Source: [www.shutterstock.com](http://www.shutterstock.com)]

- State THREE requirements that a company should meet to be able to use the FAIRTRADE logo on its products. (3)
- 4.3 Explain the relationship between *fashion* and *style*. (2)
- 4.4 Study the jacket below and answer the question that follows.



[Source: [African inspiration.com](http://African inspiration.com)]

- Discuss how social factors influence the use of African prints in South African fashion. (3)

4.5 Study the outfit below and answer the questions that follow.

	<p>This outfit consists of:</p> <ul style="list-style-type: none"><li>• Red double-breasted jacket</li><li>• Black pants</li><li>• Black leather handbag</li></ul> <p>[Source: <a href="http://www.kartzapper.com">www.kartzapper.com</a>]</p>
--	--

- 4.5.1 Explain why this outfit is suitable for the world of work as well as for a cocktail party after work. (4)
- 4.5.2 Analyse the optical illusions created by the outfit. (6)
- [20]**

**QUESTION 5: HOUSING AND INTERIOR**

- 5.1 Define the term *title deed*. (2)
- 5.2 Give the purpose of the National Home Builders' Registration Council (NHBRC). (2)
- 5.3 Differentiate between *full-title ownership* and *sectional-title ownership*. (4)
- 5.4 Read the scenario below and answer the questions that follow.

John decided to buy a house and rent it out to supplement his income. He obtained a bond from the bank to finance the buying of the house.

[Own text]

- 5.4.1 Name THREE financial responsibilities that John will have as a landlord. (3)
- 5.4.2 Explain to John the possible disadvantages of renting out his property. (6)
- 5.4.3 Explain why it would be best for John to take a fixed interest rate on the home loan. (3)
- 5.5 State FOUR factors to consider when shopping for a vacuum cleaner to ensure that it is easy to operate. (4)
- 5.6 Read the scenario below and answer the questions that follow.

Jordan and Jamie want to buy a new microwave oven. They liked the microwave oven below that they saw at a friend's place.

[Own text]

	<p style="text-align: center;"><b>FEATURES</b></p> <ul style="list-style-type: none"> <li>• Stainless steel finish</li> <li>• Clear display text</li> <li>• Automatic programming based on weight of food</li> </ul> <p style="text-align: right;">[Source: <a href="http://www.hificoorporation.co.za">www.hificoorporation.co.za</a>]</p>
---	---

Discuss the advantage(s) of the following universal design features of the microwave oven:

- 5.6.1 Stainless steel finish (2)
- 5.6.2 Clear display text (1)
- 5.6.3 Automatic programming based on the weight of the food. (2)

- 5.7 Compare the financial aspects of buying household appliances using a *bank credit card* and with using an *instalment sale transaction*.

Redraw the table below in your ANSWER BOOK to answer the question.

CREDIT CARD TRANSACTION	INSTALMENT SALE TRANSACTION
(1)	(1)
(1)	(1)

(4)

- 5.8 Read the statement below and answer the question that follows.

Climate change is causing havoc with weather patterns all over the world. Recently many homes in South Africa were destroyed by floods or fires.

[Own text]

Predict the possible financial consequences for homeowners who have lost their homes due to floods or fires.

(7)  
[40]

**QUESTION 6: ENTREPRENEURSHIP**

- 6.1 Name TWO examples of electronic media that can be used to advertise a product or a service. (2)
- 6.2 Define the following terms:
- 6.2.1 Quality control (2)
- 6.2.2 Worst-sale scenario (2)
- 6.3 Read the scenario below and answer the questions that follow.

Buhle and his three friends learnt to make homemade ginger beer at school. They saw an opportunity to start their own small-scale business selling homemade ginger beer. The ingredients were locally available and affordable. Before Buhle and his friends started their business, they visited their neighbours, friends and local municipal officials, enquiring if they were interested in buying the homemade ginger beer they would be selling.

They collected empty, used, durable plastic bottles to use as packaging. Buhle made sure that all bottles were washed in hot soapy water and sterilised before they were filled with homemade ginger beer. They wanted to keep their business as green as possible.

They produced the homemade ginger beer on weekends in his aunt's backyard room. They delivered the orders regularly. They also started receiving orders from people outside their local community who had seen the product advertised on WhatsApp and other social networks.

[Own text]

- 6.3.1 Give THREE requirements that they had to consider when choosing suitable packaging for the homemade ginger beer. (3)
- 6.3.2 Explain how FOUR of the five P's of the marketing mix were achieved by this small-scale business. (4)
- 6.3.3 Quote, from the scenario above, the statement that indicates that market research (feasibility study) has been conducted. (1)
- 6.3.4 Discuss TWO factors that Buhle and his friends had to consider before choosing the product for their small-scale business. (2 x 2) (4)
- 6.3.5 Discuss factors that could contribute to the sustainable profitability of the homemade ginger beer small-scale business. (6)



6.3.6 Read the information below and answer the questions that follow.

The cost of ingredients to produce 30 litres of homemade ginger beer is R120. They added 75% to the production costs to cover their overheads.

- (a) Calculate the production cost of 1 litre of homemade ginger beer. Show ALL calculations. (4)
- (b) Calculate the profit of 60 litres of homemade ginger beer if the mark-up is 30%. Show ALL calculations. (4)

6.3.7 Read the information below and answer the question that follows.

Using the recycled plastic bottles as packaging (containers) for the homemade ginger beer has a positive impact on the natural environment.

- Evaluate the validity of this statement. (8)  
**[40]**

**TOTAL: 200**