



basic education

Department:
Basic Education
REPUBLIC OF SOUTH AFRICA

**SENIOR CERTIFICATE/
NATIONAL SENIOR CERTIFICATE**

GRADE 12

ENGINEERING GRAPHICS AND DESIGN P2

NOVEMBER 2020

MARKING GUIDELINES

MARKS: 100

These marking guidelines consist of 8 pages.

ANSWER		
1	TWO-LEVER DOOR LOCK	1
2	SIPO	1
3	2018/09/14	1
4	DL 04	1
5	3	1
6	13 / 10	1
7	PERSPEX	1
8	BOTTOM VIEW	1
9	A: 134 B: Ø 5 C: 24 D: 88 E:2	5
10	134°, 135°, 136°	1
11	SYMMETRY	1
12	INTERRUPTED VIEW	1
13	MULTI PLANE / OFFSET SECTION	1
14	See below	2
15	□9	1
16	7	1
17	CROSSED	1
18	10,29	2
19	See below	3
20		3
TOTAL		30

ANSWER 14:

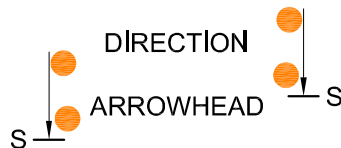

ANSWER 19: Conventional representation for a coil spring

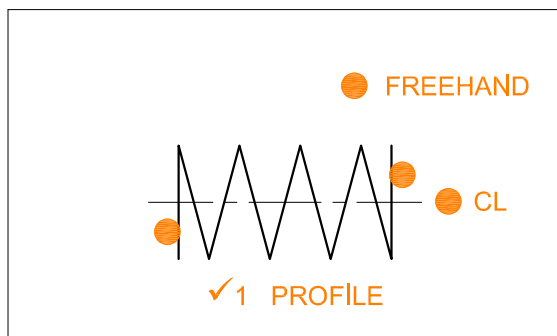

ANSWER 20: Projection symbol

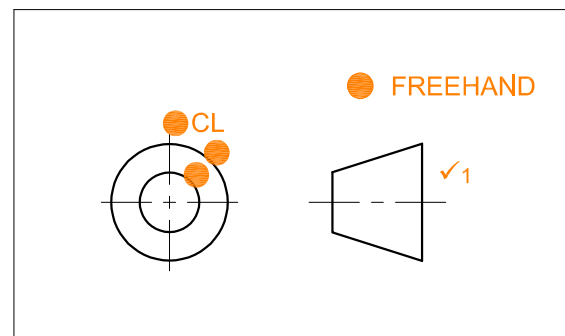

PAPER 2 QUESTION 1
 GRADE 12
 SC/NSC 2020
 MARKING GUIDELINES

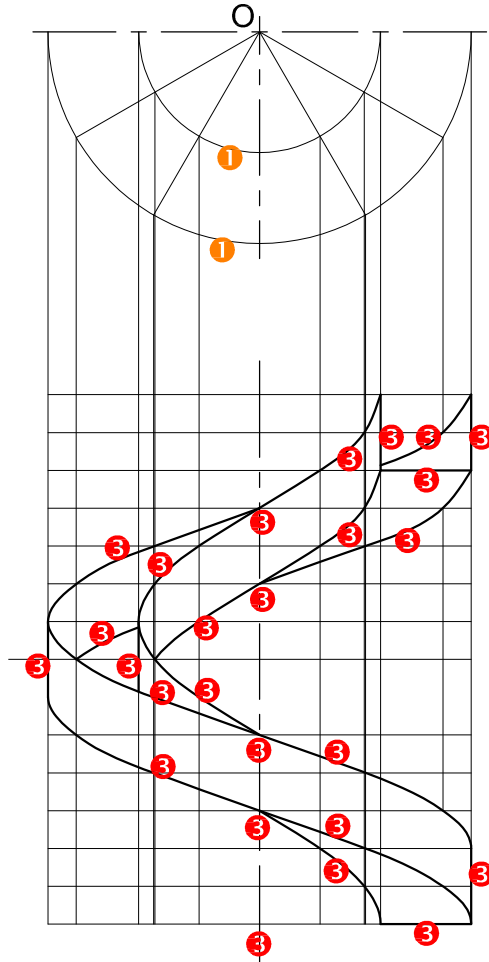

2. CONSTRUCTIONS

- CIRCLE DIVISIONS 0,5
 - PITCH 0,5
 - PITCH DIVISIONS 1
 - VERTICAL PROJECTION 1
 - HORIZONTAL PROJECTION 1
 - DIRECTION 2
- 6**

4. CURVE QUALITY

- CURVE THROUGH POINTS 1
- CURVE CONTINUOUS / SMOOTH 1/2

ASSESSMENT CRITERIA 2.1		
1	GIVEN + CL	1
2	CONSTRUCTION	6
3	HELIX	13
4	CURVE QUALITY	2
TOTAL		22

PAPER 2 QUESTION 2.1
 GRADE 12
 SC/NSC 2020
 MARKING GUIDELINE

1. CONSTRUCTIONS

- LENGTH : 120 mm 0,5
- 12 DIVISIONS 0,5

SIMPLE HARMONIC

- 15° SUBDIVISIONS 0,5
- SEMI CIRCLE 0,5
- CIRCLE DIVISION 0,5
- HORIZONTAL PROJECTION 0,5

UNIFORM ACCELERATION & RETARDATION

- 15° SUBDIVISIONS 0,5
- LINE DIVISION 0,5
- FIRST HALF CONSTRUCTION 0,5
- SECOND HALF CONSTRUCTION 0,5

LABELING 1
6

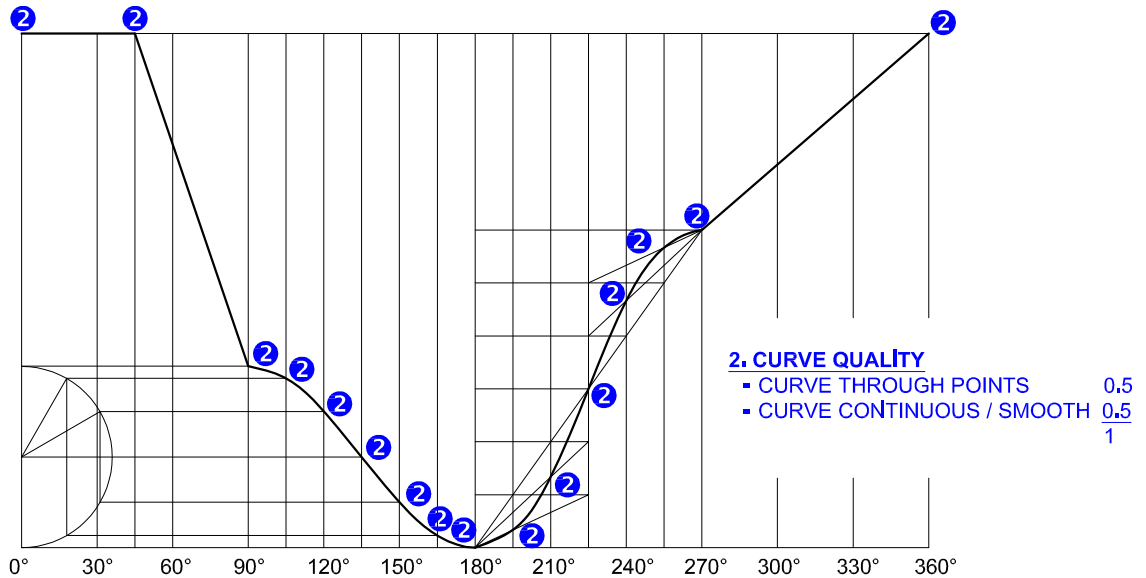

DISPLACEMENT GRAPH
SCALE 360° : 120 mm

ASSESSMENT CRITERIA 2.2		
1	CONSTRUCTION	6
2	POINTS + CURVES	9
TOTAL		15

PAPER 2 QUESTION 2.2
GRADE 12
SC/NSC 2020
MARKING GUIDELINE

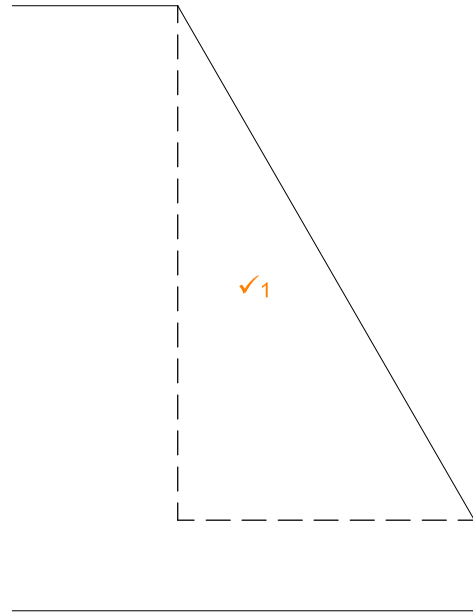
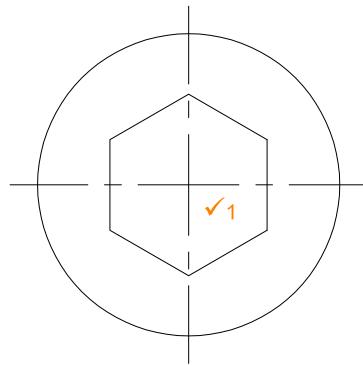

✓4 CIRCLE CONSTRUCTION

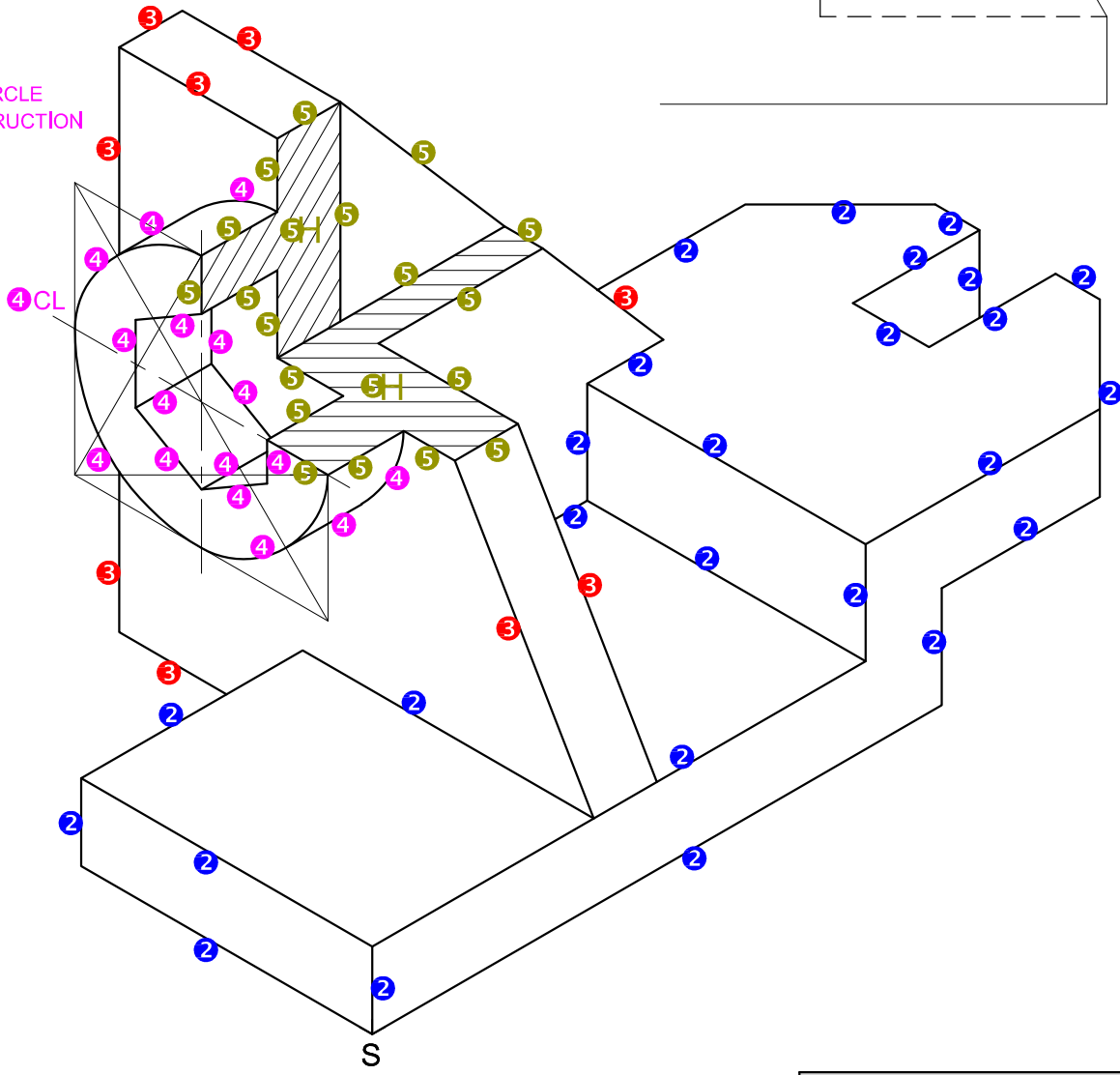

✓1 PLACEMENT

ASSESSMENT CRITERIA		
1	PLACEMENT + AUX VIEW	3
2	BASE	13
3	UPRIGHT	4½
4	CIRCLE + HEXAGON	9½
5	SECTION	10
TOTAL		40

PAPER 2 QUESTION 3
 GRADE 12
 SC/NSC 2020
 MARKING GUIDELINE

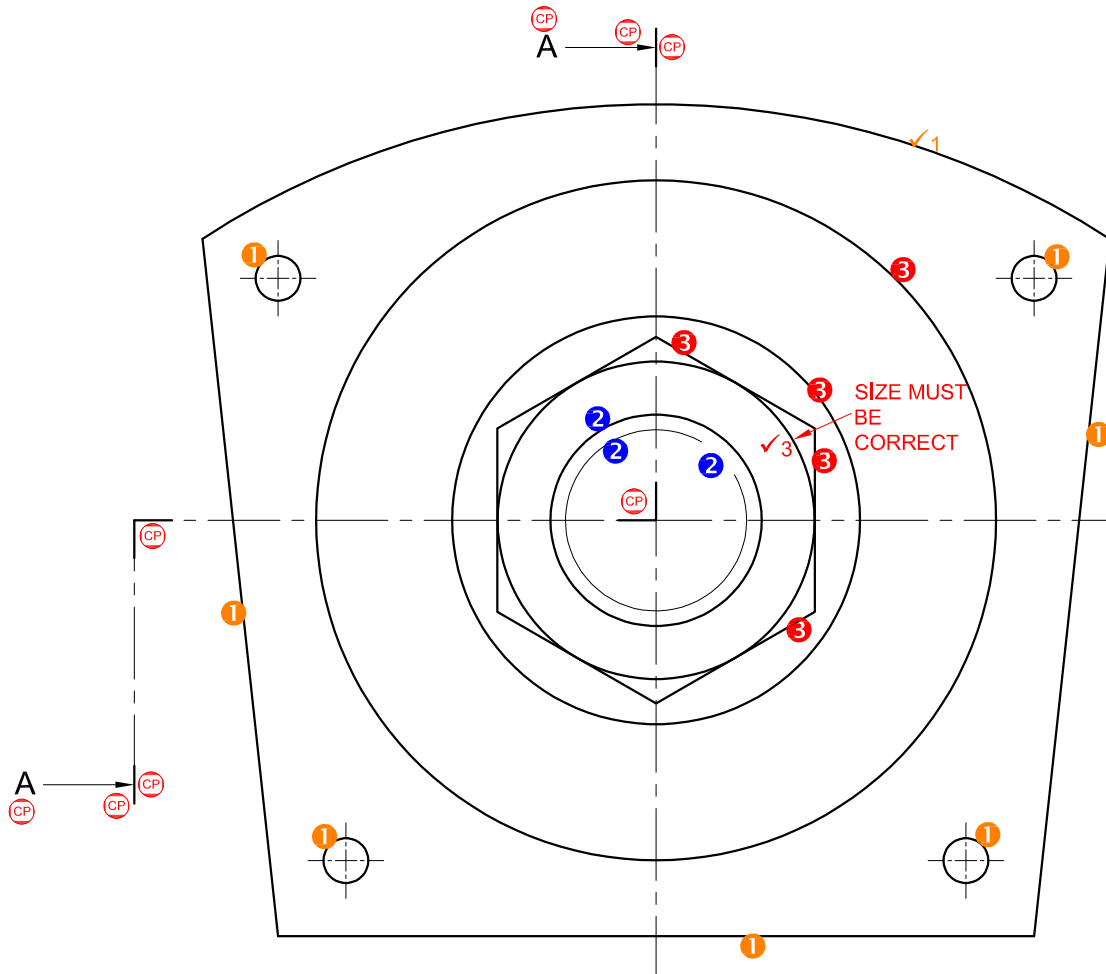

1. CENTRE LINE MARK ALLOCATION

SANS COMPLIANT (LINE TYPE)	2
CENTRE LINES	
(0 to 3 = 0); (4 to 9 = 1); (10 to 13 = 2)	2
TOTAL	4

3. ASSEMBLY

1 MARK FOR EVERY COMPONENT
CORRECTLY ASSEMBLED
(10 PARTS • 1) = 9

ASSESSMENT CRITERIA		
RIGHT VIEW		
1	BODY	4½
2	SHAFT	1½
3	M28 NUT + FLANGE	3½
SUBTOTAL		9½

PAPER 2 QUESTION 4
GRADE 12
SC/NSC 2020
MARKING GUIDELINE

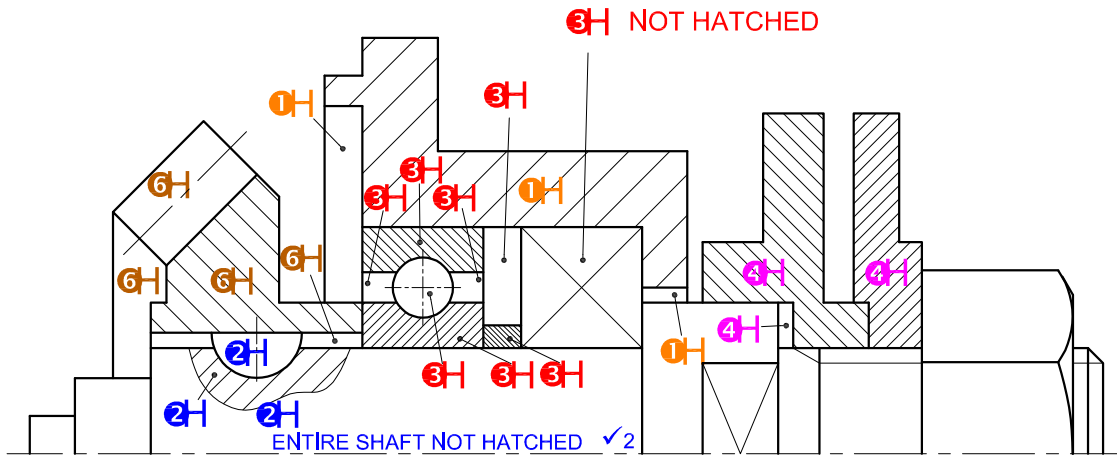

MARK ALLOCATION FOR HATCHING

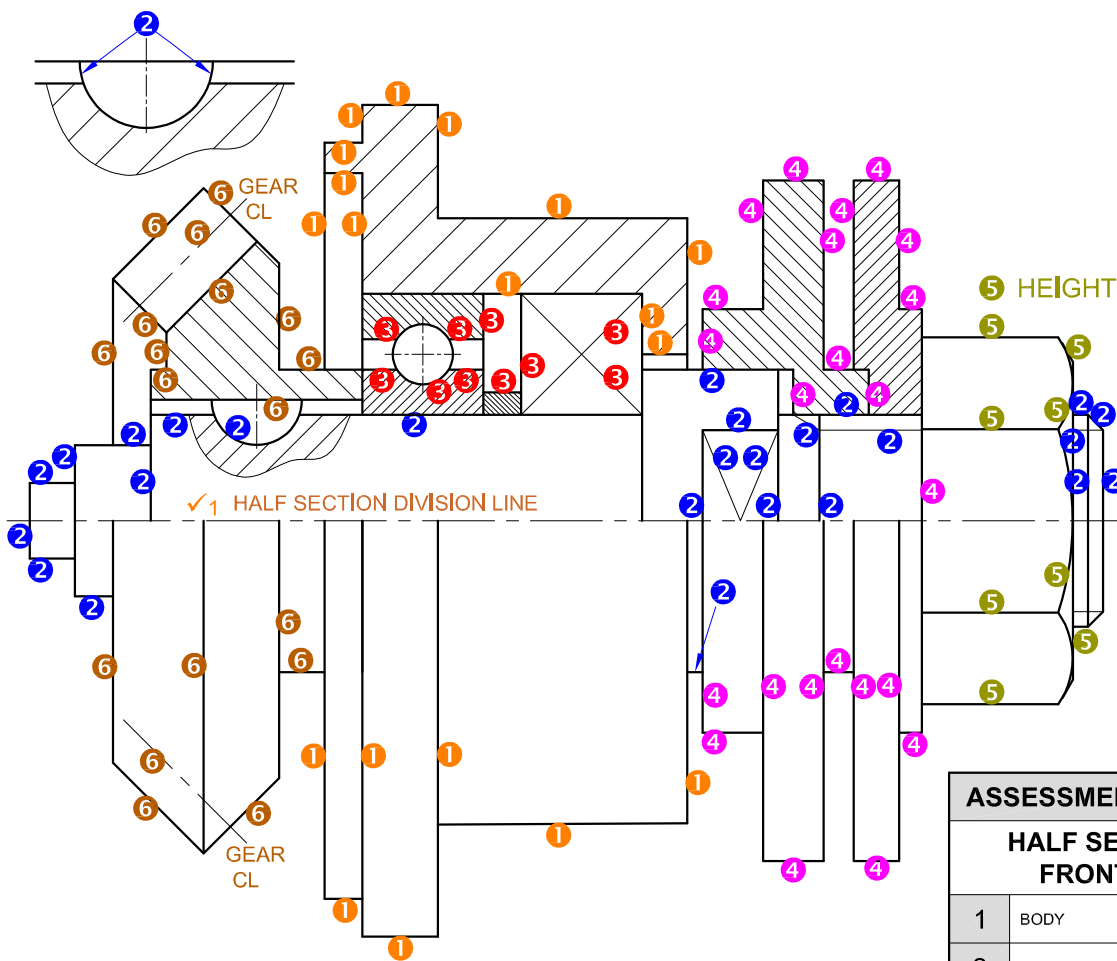

NOT SECTIONED / HATCHED IN BOTTOM HALF ✓1

ASSESSMENT CRITERIA		
HALF SECTIONAL FRONT VIEW		
1	BODY	13
2	SHAFT + KEY	16
3	BEARING + SPACER	9
4	FLANGES	13
5	M28 NUT	4½
6	GEAR	11
SUBTOTAL		66½
GENERAL		
2	CUTTING PLANE A-A	4
3	ASSEMBLY	9

PAPER 2 QUESTION 4
 GRADE 12
 SC/NSC 2020
 MARKING GUIDELINE