

MATHEMATICS GRADE 5 TEACHER GUIDE

MATHEMATICS GRADE 5

TEACHER GUIDE



basic education
Department:
Basic Education
REPUBLIC OF SOUTH AFRICA



Mathematics

Grade 5

Teacher Guide



Developed and funded as an ongoing project by the Sasol Inzalo Foundation in partnership with the Ukuqonda Institute

Published by

The Ukuqonda Institute

<http://www.ukuqonda.org.za>

9 Neale Street, Rietondale 0084, South Africa

Title 21 Company, Reg. No. 2006/026363/08

Public Benefit Organisation, PBO No. 930035134

© 2016. Copyright in the work is vested in the publisher. Copyright in the text remains vested in the authors.

Mathematics Teacher Guide Grade 5

ISBN: 978-1-4315-2291-0

This Teacher Guide and its accompanying Learner Book (ISBN: 978-1-4315-2288-0) were developed with the participation of the Department of Basic Education of South Africa (DBE) with funding from the Sasol Inzalo Foundation (SaIF).

Authors: Piet Human, Alwyn Olivier, Heather Collins, Carol MacDonald, Erna Lampen, Amanda le Roux, Andrew Hofmeyr, Manare Setati, Peter Moodie, John Laurie, Chris Human, Paul van Koersveld, Annette Nell

Contributors: Malcolm Samuel Alexander, Joseph James Gordon, Funaki Junko, John Bob Kolokoto, Nombuso Makhaza, Sylvia Sindiswa Mcosana, Thulisizwe Msomi, Victor Siphon Mthombeni, Cebisa Faith Mtumtum, Basil Sakoor, David Sekao, Nomvuyo Maureen Thobela, Patricia Whitten, Roselinah Sizane Zwane, Millard Zweni

Layout and typesetting: The authors and the Ukuqonda Institute

Illustrations and computer graphics: The authors; the Ukuqonda Institute; Lisa Steyn (p. 255)

Photographs p. 371: Nico Hamp (wall); Elsa Retief (honeycomb)

IT solution and support for file sharing: Menge Media

Cover design and illustration: Leonora van Staden and Piet Human

Acknowledgements relating to the Learner Book pages: Layout and typesetting: Anton Stark, Lebone Publishing Services. Text design: Mike Schramm. Illustrations and computer graphics: Leonora van Staden; Piet Human; Lisa Steyn; Zhandré Stark (Lebone Publishing Services). Photographer: Martin van Niekerk. Other photographs: p. 91: The African Rock Art Digital Archive; pp. 181, 333 and 334: 34 Fine Art and Esther Mahlangu; pp. 312 and 314: Kim Stevens; p. 168: Shutterstock; p. 92: Piet Human; pp. 97 and 98: Leonora van Staden. Painting on p. 92: Miemie Naude, Kroonstad.

Rights of other copyright holders: All reasonable efforts have been made to ensure that materials included are not already copyrighted to other entities, or in a small number of cases, to seek permission from and acknowledge copyright holders. In some cases this may not have been possible. The publishers welcome the opportunity for redress with any unacknowledged copyright holders.

Printed by:

Your freedom to legally copy this book

This work is published under a Creative Commons Attribution-NonCommercial 4.0 Unported License (CC BY-NC 4.0).



<http://creativecommons.org/licenses/by-nc/4.0/>

You are allowed to freely copy this book subject to the qualifications below. You can photocopy, print and distribute it as you like. You may download it onto any electronic device, distribute it via email, and upload it to your website, at no charge. You may also adapt the text and illustrations.

Attribution: When doing any of the above, you should provide clear acknowledgement of the license/copyright holders ('attribute the original work'). This attribution should include the name(s) of the original book(s) and the publisher, as well as acknowledgement of the SaIF and the DBE of South Africa. You should also provide the Creative Commons web address which explains this type of license:

<http://creativecommons.org/licenses/by-nc/4.0/>

If you made changes to the material, you must indicate what changes you have made. You may not in any way suggest that the licensor endorses you or your use of your material or your changes to the material.

Restrictions: *You may not make copies* of this book or a part of this book – in printed or electronic or audio or video or whatever form – *for a profit-seeking purpose.*

Limited rights on use of photos: A photograph in the book that shows a person or trademark emblem/insignia in an even slightly recognisable manner may not be used out of its learning context, and may not be used for an intended audience other than learners/students and teachers. A photo containing a person or trademark emblem/insignia may only be used in a web page or in print or in a slide show (or in any other media) if it is for a not-for-profit teaching/learning purpose, and if the photo on that page/web page/slide/other media is accompanied by related learning material(s) that is at least as big as the photo itself.

No photograph in the book may be used for promotional or advertising purposes, even if such promotion or advertising is not for a profit-seeking purpose.

No photograph in the book that shows a person may be used on the cover of any derived work, or in any media in a way equally prominent to the cover of a book.

Contents

Term 1

Unit 1: Whole numbers	3
Unit 2: Number sentences	14
Unit 3: Whole numbers: Addition and subtraction	23
Unit 4: Numeric patterns	48
Unit 5: Whole numbers: Multiplication and division	59
Unit 6: Time	74
Unit 7: Data handling	87
Unit 8: Properties of two-dimensional shapes	98
Unit 9: Capacity and volume	112

Term 2

Unit 1: Whole numbers	123
Unit 2: Whole numbers: Addition and subtraction	130
Unit 3: Common fractions	140
Unit 4: Length	155
Unit 5: Whole numbers: Multiplication	170
Unit 6: Properties of three-dimensional objects	181
Unit 7: Geometric patterns	191
Unit 8: Symmetry	197
Unit 9: Whole numbers: Division	204

Term 3

Unit 1: Common fractions	217
Unit 2: Mass	230
Unit 3: Whole numbers	238
Unit 4: Whole numbers: Addition and subtraction	244
Unit 5: Viewing objects	255
Unit 6: Properties of two-dimensional shapes	259
Unit 7: Transformations	266
Unit 8: Temperature	277
Unit 9: Data handling	283
Unit 10: Numeric patterns	291
Unit 11: Whole numbers: Multiplication	297

Term 4

Unit 1: Whole numbers	311
Unit 2: Whole numbers: Addition and subtraction	316
Unit 3: Properties of three-dimensional objects	326
Unit 4: Common fractions	336
Unit 5: Whole numbers: Division	346
Unit 6: Perimeter, area and volume	355
Unit 7: Position and movement	369
Unit 8: Transformations	372
Unit 9: Geometric patterns	378
Unit 10: Number sentences	383
Unit 11: Probability	388
Addendum	393

Term 1

Unit 1: Whole numbers	3
1.1 Counting	4
1.2 Place value	10
1.3 Counting, ordering and comparing numbers	12
Unit 2: Number sentences	14
2.1 State addition and subtraction facts	15
2.2 Solve and complete number sentences	19
2.3 Equivalence	22
Unit 3: Whole numbers: Addition and subtraction	23
3.1 Addition and subtraction facts	24
3.2 Addition, subtraction and doubling	27
3.3 Doubling and other ways to make facts	31
3.4 Add and subtract multiples of 100 and 1 000	36
3.5 Rounding off and compensating	38
3.6 Use brackets to describe your thinking	40
3.7 Add and subtract 4-digit numbers	43
3.8 Round off, estimate and solve problems	45
Unit 4: Numeric patterns	48
4.1 Patterns in the tables	50
4.2 Equivalent flow diagrams	52
4.3 Sequences of non-multiples	55
4.4 Flow diagrams and rules	58
Unit 5: Whole numbers: Multiplication and division	59
5.1 What is multiplication?	60
5.2 Multiplication facts	63
5.3 Double, double and double again	64
5.4 Multiply by building up from known parts	66
5.5 Strengthen your knowledge of multiplication facts	67
5.6 Practise multiplication and solve problems	69

5.7 Multiples, factors and products	70
5.8 Division	72
Unit 6: Time	74
6.1 A little history	75
6.2 Daytime hours and night-time hours	76
6.3 Read, tell and write time	77
6.4 Intervals of time	80
6.5 Calendar time	84
6.6 Years and decades	86
Unit 7: Data handling	87
7.1 Asking questions about a situation	88
7.2 Drawing and interpreting graphs	90
7.3 Summarising and analysing data	93
7.4 Project	97
Unit 8: Properties of two-dimensional shapes	98
8.1 Curved and straight lines	99
8.2 Figures with different shapes	102
8.3 Angles	105
8.4 Right angles around us	107
8.5 Angles and sides in two-dimensional figures	109
Unit 9: Capacity and volume	112
9.1 Capacity and volume	113
9.2 Make a measuring jug	116
9.3 Litre and millilitre	117
9.4 Calculations and problem solving	119

Learner Book Overview		
Sections in this unit	Content	Pages in Learner Book
1.1 Counting	Counting in groups	3 to 8
1.2 Place value	Representing numbers with place value cards, and in other ways	9 to 10
1.3 Counting, ordering and comparing numbers	Arranging numbers from smallest to biggest, and the other way round	11 to 12

CAPS time allocation	2 hours
CAPS page references	13 to 15 and 125 to 126

Mathematical background

Although a number symbol such as 357 is *formed* by writing the three digits 3, 5 and 7, the number represented by the symbol 357 is not “three five seven” or “3 and 5 and 7”, but $300 + 50 + 7$. This is what is meant by “understanding place value”. It should be made clear from the outset and emphasised whenever possible. Language constructions such as “break down a number into its place value parts” and learning aids such as place value cards were invented and are prescribed to promote understanding of place value.

There is a difference between **number symbols**, which are composed of digits, and the **numbers as ideas**, which are composed of units, tens, hundreds, etc. Probably the most dangerous **misconception** that learners can form about whole numbers is that numbers are composed of digits, for example that **the number 357** is made up of the digits 3, 5 and 7.

A distinction can be made between the “face value” of a digit in a number symbol, the “numerical value” or number (place value part) represented by the digit, and the place value of the position occupied by the digit. For example, in 357 the **face value** of the symbol “5” is 5. However, the symbol “5” represents the number 50, hence its **numerical value** is 50. The symbol “5” is in the tens position, a fact that is sometimes expressed by saying that the **place value** of the digit (actually the place value of the position it occupies) is tens (note the plural).

Resources

Two resources are absolutely critical for the work in this unit:

- Counting apparatus: wooden or plastic cubes and rods, or sticks and stick bundles
- Place value cards, all of the same colour, for units, tens, hundreds and thousands, and preferably for ten thousands too.

Each learner should have their own set of counters (cubes/rods or sticks/bundles) and their own set of place value cards.

In addition, you should have a set of large place value cards for demonstration purposes.

Master copies for place value cards are provided in the Addendum at the back of this Teacher Guide (see pages 394 to 411).

1.1 Counting

Critical knowledge and skills

There is a huge difference between

- A. saying the number names in sequence: “one, two, three, four, five, six, seven, eight ...”, and
- B. establishing how many objects there are in a given collection.

However, the ability to say the number names in sequence is a prerequisite for establishing the number of objects in a collection.

It is critical that learners understand counting not only as counting objects one by one, but also as structured counting in groups of ten, hundred, thousand, and so on.

Counting structured collections such as those on pages 4 to 7 (and similar pages in the Grade 4 and 6 Learner Books) can promote understanding of the base-ten positional number system (place value).

Teaching guidelines

Observe how learners approach question 1. Learners who try to count one by one need support, such as that described on the next page. Suggest to learners that they should consider how many stripes there are in each of the columns, and how many columns there are.

Notes on questions

Questions 3 to 5 are specifically designed to promote structured counting.

Answers

1. 100
2. 3
3. (a) 30 (b) 300 (c) 100 (d) 3 000
4. 6 000
5. (a) 10 000 (b) 100 (c) 1 000
6. 9 000

UNIT1WHOLE NUMBERS

1.1 Counting

Look at the next four pages. You will see four arrays (arrangements) of stripes. You will soon find out how many stripes there are!
You already know that ten tens are 100.

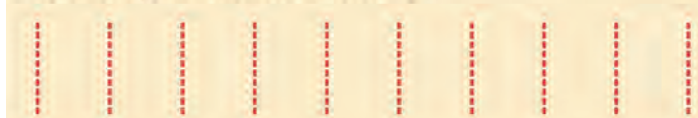

Ten hundreds are 1 000. You can see this in Array A on the next page.
Ten thousands are 10 000.

1. How many tens are shown in Array A on the next page?
2. How many hundreds are shown below?



3. (a) Now turn to Array B. How many hundreds are shown in the array?
(b) How many tens are shown in Array B?
(c) How many thirties are shown in Array B?
(d) How many stripes are shown in Array B?
4. Turn to Array C. How many stripes are shown in Array C?
5. (a) Turn to Array D. How many stripes are shown in Array D?
(b) How many hundreds are shown in Array D?
(c) How many tens are shown in Array D?
6. How many stripes are shown in Arrays B and C together?

GRADE 5: MATHEMATICS [TERM 1] 3

Teaching guidelines

Learners may fail to notice the structure of the array: that it consists of columns of 10 stripes each, with 10 such columns in a row (i.e. 100 stripes in a row), and 10 such rows from top to bottom.

One way in which you can help learners is to ask them to find a **group** of 10 stripes that are close together anywhere on the page. Ask them to point at such a group with a finger. Then ask them to point out another group of 10 stripes. Then ask how many such groups there are on the page as a whole.

It may also help learners if you introduce the ideas of **rows** and **columns**. You could make a drawing such as the one below on the board to serve as a reference for this.

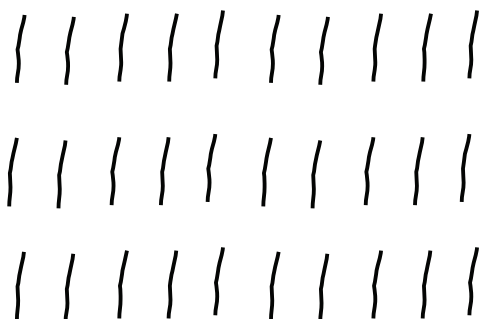

Explain to learners that you have drawn three **rows** of 10 lines each. To help them to pay attention to what you have explained, ask them to make a drawing with four rows of six lines each in their exercise books. Monitor their work.

Use your drawing on the board to show learners what a **column** is. Ask them how many lines there are in each of the columns on the board (three). Ask them how many lines there are in each of the columns in the drawing they have made (four). You may also ask them how many columns of three lines each you have drawn on the board (ten).

Additional questions you may ask

1. How many stripes would there be on two pages like this?
2. How many stripes would there be on five pages like this?
3. How many stripes would there be on ten pages like this?
4. How many stripes would there be on $1\frac{3}{4}$ pages like this?

Array of stripes A

4 UNIT 1: WHOLE NUMBERS

Teaching guidelines

In Array B the stripes are grouped in 30s with ten groups in one row.

Some learners may still feel safer to count in 10s, while others may try to count in 30s.

Learners with a well-developed number concept will be able to see almost immediately that there are 3 000 stripes on the page.

The stripes in Array C on the next page are arranged in 60s and again there are ten groups in a row. If learners reason about the situation, they should realise that Array C has exactly double the number of stripes as Array B.

Additional questions you may ask

1. How many stripes would there be on two pages like this?
2. How many stripes are there in six of the ten rows?
3. How many stripes are there in six of the ten columns?
4. How many stripes would there be on three pages like this?
5. How many stripes would there be on $1\frac{2}{5}$ pages like this?

Array of stripes B

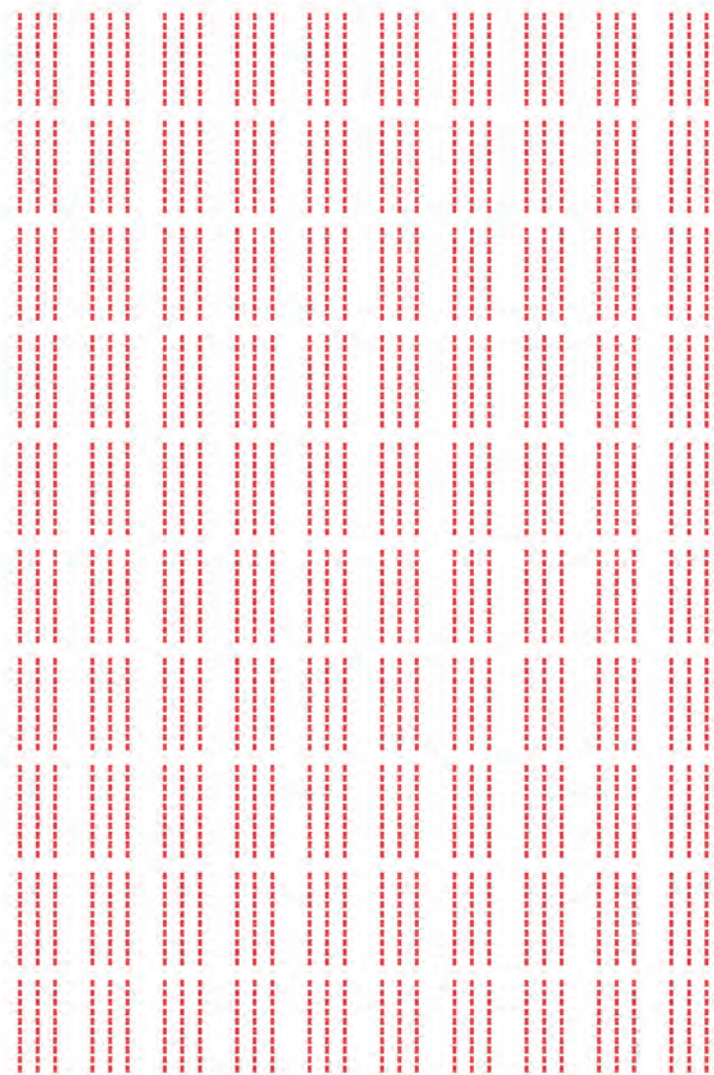

Additional questions you may ask

1. How many stripes are there in two of the ten rows?
2. How many stripes are there in three of the ten columns?
3. How many stripes would there be on two pages like this?
4. How many stripes would there be on $1\frac{3}{5}$ pages like this?
5. An array consists of 100 groups of 500 stripes each. How many groups of 250 stripes each will be the same number of stripes in total?

Array of stripes C

6 UNIT 1: WHOLE NUMBERS

Additional questions you may ask

Learners can subtract mentally or count backwards in multiples to find the answers.

1. How many stripes will there be if three rows of stripes are removed from the array?
2. How many stripes will there be if four columns are removed?
3. How many stripes will there be if ten groups of 100 stripes are removed?
4. How many stripes will there be if four groups of 100 stripes are removed?
5. How many stripes will there be if five stripes are removed?

Additional counting activities

1. Count the stripes on this page by counting in 100s.
2. Count the stripes on this page by counting aloud in 200s.
3. Count backwards from 10 000 to 0 in 1 000s.
4. Count backwards from 1 000 to 0 in 500s.

Array of stripes D

GRADE 5: MATHEMATICS [TERM 1] 7

Answers

7. (a) 4 264
(b) 736

Additional questions you may ask

1. How many more stripes are needed to fill this page up to 8 000?
2. How many more stripes are needed to fill this page up to 10 000?
3. How many more stripes are needed to fill this page up to 7 500?

7. (a) How many stripes are shown below?

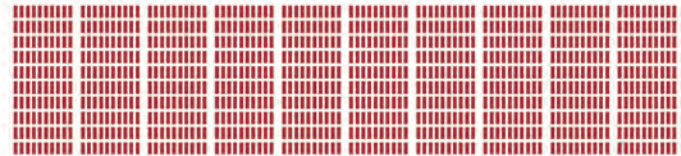
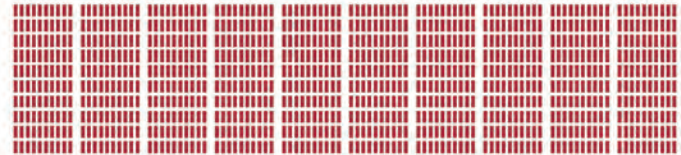
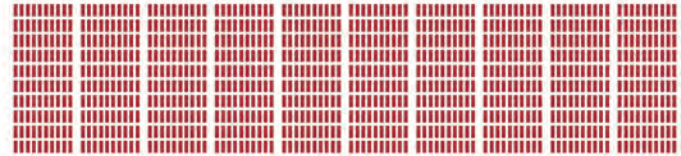

(b) How many more stripes are needed to fill this up to 5 000?

1.2 Place value

Teaching guidelines

Although pictures of place value cards are provided on many pages of the Learner Book, it is critical that each learner has their own set of place value cards like those given in the Addendum on pages 394 to 397. They also need place value apparatus such as wooden or plastic cubes and rods, or sticks and bundles of sticks. These concrete materials are indispensable supports for the development of number concept, and contribute to the understanding of place value.

Although a number symbol such as 357 is written (formed) by writing the three digits 3, 5 and 7, the number represented by the symbol 357 is not “three five seven”, but $300 + 50 + 7$. This should be made clear from the outset and emphasised whenever possible. **Numbers are ideas; number symbols and number names are marks on paper or words and sounds.** The reading of a number symbol by saying the digits should be discouraged: numbers should be read by saying the full number names. A simple but powerful classroom activity is to write a number symbol on the board and ask learners to read it aloud. Such oral work may be extended by asking questions such as: “How many tens are in 67?”, “How many hundreds are in 368?”

Place value cards are an indispensable tool to help learners to distinguish, in their own minds, between number symbols and the numbers themselves. It is important to use place value cards correctly. The basic place value card activity is to ask learners to “show” a number with cards. When learners are asked to show a number, for example 357, they should select and hold up the $\overline{300}$, $\overline{50}$ and $\overline{7}$ cards, not the $\overline{3}$, $\overline{5}$ and $\overline{7}$ cards.

Answers

- (a) 7 948 (b) 6 853 (c) 1 045
(d) 3 975 (e) 4 008
- (a) 1 000, 200, 70, 3 (b) 6 000, 500, 20, 5
(c) 3 000, 300, 50, 7 (d) 2 000, 10, 5
(e) 5 000, 40, 2 (f) 1 000, 500, 80, 9

1.2 Place value

The number symbol for seven thousand four hundred and sixty-five is 7 465. The number symbol can be built up with place value cards:

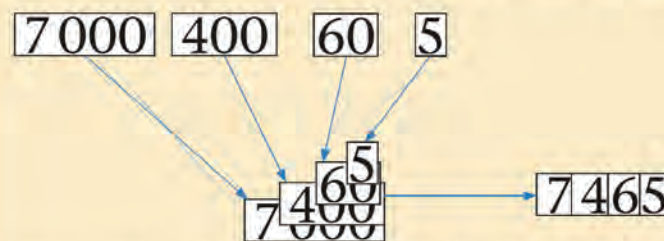

In the number symbol 7 465 we cannot see the place value parts 7 000, 400 and 60.

The 000 of the 7 000, the 00 of the 400 and the 0 of the 60 are hidden. Instead of 7 000, only “7” is written in the number symbol.
Instead of 400, only “4” is written in the number symbol.
Instead of 60, only “6” is written in the number symbol.

- Write the number symbols for these numbers.
 - seven thousand nine hundred and forty-eight
 - six thousand eight hundred and fifty-three
 - one thousand and forty-five
 - three thousand nine hundred and seventy-five
 - four thousand and eight

The **place value parts** of 7 465 are 7 000, 400, 60 and 5.

- Write the place value parts of each number.
 - 1 273 (b) 6 525
 - 3 357 (d) 2 015
 - 5 042 (f) 1 589

Possible misconceptions

A major purpose of using place value cards is to protect learners against forming the misconception that a number itself is composed of the single-digit numbers represented by the digits when used separately. The 5 in 57 is something else than the 5 in 35 or in 5. The 5 in 57 represents 50, not 5. You should consistently keep in mind that there is a difference between number symbols, which are composed of digits, and the numbers as ideas, which are composed of units, tens, hundreds, etc. This is what is meant by “understanding place value”.

Teaching guidelines

Place value cards can be used to demonstrate the relationship between expanded notation and number symbols. The number 627 can be represented in two ways with place value cards, namely

as

600	20	7
-----	----	---

and as

6	2	7
---	---	---

These two ways of arranging the place value cards correspond to the expanded notation and the number symbol.

Answers

3. (a) $1\ 000 + 200 + 70 + 3$ (b) $6\ 000 + 500 + 20 + 5$
(c) $2\ 000 + 10 + 5$
4. (a) 6 (b) 4
5. (a) 4 (b) 8
6. (a) 3 758 (b) 1 376
(c) 8 206 (d) 8 026
(e) 6 040 (f) 6 004

The **expanded notation** for 7 465 is $7\ 000 + 400 + 60 + 5$.

3. Write the expanded notation for each of these numbers.
(a) 1 273 (b) 6 525 (c) 2 015

The “7”, the “4”, the “6” and the “5” in the number symbol 7 465 are called **digits**.

The digit “7” in the number symbol 7 465 means 7 000 or 7 thousands because it is in the thousands place.

Any digit in this position indicates thousands.

thousands	hundreds	tens	units
7	4	6	5

$7\ 465 = 7\ \text{thousands} + 4\ \text{hundreds} + 6\ \text{tens} + 5\ \text{units}$

$7\ 465 = 7\ 000 + 400 + 60 + 5$

The **value** or meaning of a digit in a number symbol depends on the position or **place** of the digit in the number symbol.

4. (a) Which digit is in the tens place in the number symbol 7 465?
(b) Which digit in the symbol 7 465 represents the number 400?
5. The digit in the hundreds place in 8 243 is 2.
(a) Which digit is in the tens place in 8 243?
(b) Which digit is in the tens place in 4 283?
6. The expanded notation for some numbers is given below. Write the number symbols for these numbers.
(a) $700 + 50 + 3\ 000 + 8$ (b) $70 + 300 + 6 + 1\ 000$
(c) $8\ 000 + 200 + 6$ (d) $8\ 000 + 20 + 6$
(e) $6\ 000 + 40$ (f) $6\ 000 + 4$

1.3 Counting, ordering and comparing numbers

Teaching guidelines

As a “warm-up” for the activities in this section, you may ask learners to softly count (individually) in 500s from 500 up to 5 000 and write the number symbols as they go along.

You may also ask some of the following similar questions:

- Count softly in 400s by yourself, starting at 0 and going up to 4 000. Write the number symbols as you go along.
- Count softly in 400s by yourself, starting at 100 and going up to 4 100. Write the number symbols as you go along.
- Count softly in 400s by yourself, starting at 200 and going up to 4 200. Write the number symbols as you go along.
- Count softly in 400s by yourself, starting at 300 and going up to 4 300. Write the number symbols as you go along.

Answers

- | | | |
|-----------|-----------|-----------|
| (a) 4 800 | (b) 3 090 | (c) 4 088 |
| (d) 4 008 | (e) 3 200 | (f) 3 150 |

Arranged from smallest to biggest: 3 090 3 150 3 200 4 008 4 088 4 800
-
-
- | | | | | | | | | | |
|-----|-------|-------|-------|-------|-------|-------|-------|-------|-------|
| (a) | 3 250 | 3 255 | 3 260 | 3 265 | 3 270 | 3 275 | 3 280 | 3 285 | 3 290 |
| | 3 295 | 3 300 | | | | | | | |
| (b) | 3 250 | 3 275 | 3 300 | 3 325 | 3 350 | 3 375 | 3 400 | 3 425 | 3 450 |
| (c) | 3 250 | 3 300 | 3 350 | 3 400 | 3 450 | | | | |
| (d) | 2 158 | 2 163 | 2 168 | 2 173 | 2 178 | 2 183 | 2 188 | | |
| (e) | 2 133 | 2 183 | 2 233 | 2 283 | 2 333 | | | | |
| (f) | 2 127 | 2 152 | 2 177 | 2 202 | 2 227 | 2 252 | 2 277 | 2 302 | 2 327 |

1.3 Counting, ordering and comparing numbers

- Write the number symbols for these numbers and arrange them from smallest to biggest.
 - four thousand eight hundred
 - three thousand and ninety
 - four thousand and eighty-eight
 - four thousand and eight
 - three thousand two hundred
 - three thousand one hundred and fifty

- (a) Copy the number line.



- (b) Write the numbers 6 200, 6 400 and 6 800 at the marks where they belong on your number line.

- (a) Copy this number line with ten marks.



- (b) Write these numbers at the marks on your number line, from smallest to biggest. Leave marks open for the missing numbers.

6 330 6 390 6 370 6 310 6 350 6 380 6 320

- Write the numbers down as you go along in each counting task.
 - Count forwards in 5s from 3 250 up to 3 300.
 - Count forwards in 25s from 3 250 up to 3 450.
 - Count forwards in 50s from 3 250 up to 3 450.
 - Count forwards in 5s from 2 158 until you reach 2 188.
 - Count forwards in 50s from 2 133 until you reach 2 333.
 - Count forwards in 25s from 2 127 until you reach 2 327.

Answers

5. (a) 3 250 3 240 3 230 3 220 3 210 3 200 3 190 3 180
3 170 3 160 3 150
- (b) 3 254 3 244 3 234 3 224 3 214 3 204 3 194 3 184
3 174 3 164 3 154 3 144
- (c) 3 250 3 245 3 240 3 235 3 230 3 225 3 220 3 215
3 210 3 205 3 200
- (d) 3 227 3 222 3 217 3 212 3 207 3 202 3 197 3 192
3 187 3 182 3 177
- (e) 3 250 3 225 3 200 3 175 3 150 3 125 3 100
- (f) 3 250 3 200 3 150 3 100 3 050 3 000
6. (a) 2 600 (b) 3 200 (c) 3 800 (d) 4 400
(e) 5 000 (f) 5 600 (g) 6 200 (h) 6 800
(i) 7 400 (j) 8 000
7. (a) $3\,492 < 9\,002$ (b) $6\,768 < 6\,879$
(c) $2\,901 > 2\,899$ (d) $5\,536 < 6\,355$

5. Write the numbers down as you go along in each counting task.

- (a) Count backwards in tens from 3 250 down to 3 150.
(b) Count backwards in tens from 3 254 until you pass 3 150.
(c) Count backwards in fives from 3 250 down to 3 200.
(d) Count backwards in fives from 3 227 until you pass 3 180.
(e) Count backwards in twenty-fives from 3 250 down to 3 100.
(f) Count backwards in fifties from 3 250 down to 3 000.

6. Write down the numbers that should be in the blocks in the diagram. For example, the answer for (a) is 2 600.

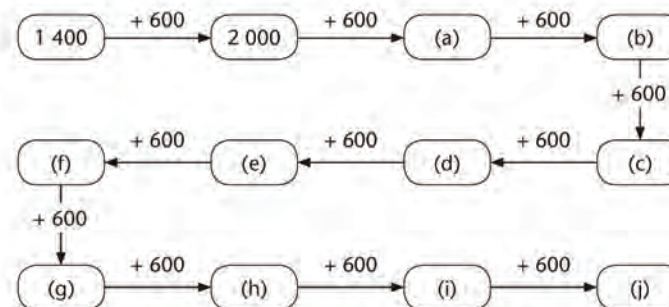

The $<$ sign for “smaller than” can be used to state that one number is smaller than another. For example, we can write $23 < 24$ and $1\,999 < 9\,991$.

The $>$ sign for “bigger than” can be used to state that one number is bigger than another. For example, we can write $24 > 23$ and $3\,492 > 1\,274$.

Notice that the open part of the sign is always towards the bigger number.

7. In each case decide which is the bigger of the two numbers. Use the $<$ or $>$ sign to write your answers.

- (a) 3 492 and 9 002 (b) 6 768 and 6 879
(c) 2 901 and 2 899 (d) 5 536 and 6 355

Learner Book Overview		
Sections in this unit	Content	Pages in Learner Book
2.1 State addition and subtraction facts	The concept of equivalence and conventions for writing calculation plans	13 to 16
2.2 Solve and complete number sentences	Open and closed sentences, and Mental Mathematics	17 to 19
2.3 Equivalence	Properties of operations	20

CAPS time allocation	3 hours
CAPS page references	20 and 127 to 131

While providing opportunities to develop understanding of number sentences, the following questions also address the content specified in the **Mental Mathematics** section of the CAPS:

- question 5 in Section 2.1
- questions 9 to 12 in Section 2.2
- question 4 in Section 2.3.

Questions 11 and 12 of Section 2.2 may be regarded as **enrichment**. Learners who complete questions 1 to 10 faster than others can also engage with questions 11 and 12.

Mathematical background

A number sentence is a statement about **numbers**, for example $3 \times 12 + 5 \times 12 = 8 \times 12$.

A number sentence is a **sentence**; the verb is =, “equals”, “is equal to” or “is equivalent to”.

$3 \times 12 + 5 \times 12$ is an expression. It can be called a **calculation plan**, a description of the intention to perform certain calculations.

A number sentence with expressions on both sides of the equal sign, for example $3 \times 12 + 5 \times 12 = 8 \times 12$, is a **statement of equivalence**.

It states that the two different calculation plans will produce the same number, which in this case is 96.

2.1 State addition and subtraction facts

Mathematical notes

This section is about the concept of equivalence, and the conventions that are to be followed when writing and interpreting the calculation plans that form the building blocks of a symbolic **statement of equivalence**.

The fact that two different sets of calculations (calculation plans) with the same numbers produce the same answer can be expressed in the form of a number sentence. For example, the fact that $3 \times 40 + 3 \times 8$ and $3 \times (40 + 8)$ give the same answer can be expressed with the number sentence

$$3 \times (40 + 8) = 3 \times 40 + 3 \times 8$$

Such a number sentence is called a statement of equivalence.

Number sentences can be **true** or **false**, for example

$$5 \times (3 + 4) = 5 \times 3 + 4 \text{ is false, but}$$

$$5 \times (3 + 4) = 5 \times 3 + 5 \times 4 \text{ is true.}$$

Teaching guidelines

You may use the tinted passage on page 13 of the Learner Book as a guideline for a presentation to explain what a statement of equivalence is.

Questions 1 and 2 are questions for learning, and are hence critical.

Question 1 provides learners with an opportunity to write statements of equivalence. Question 2 alerts learners to the difference between true and false statements.

Answers

- (a) $5 + 5 + 5 + 5 + 5 + 5 + 5 + 5 + 5 + 5 + 5 + 5 + 5 + 5 + 5 + 5 + 5 + 5 + 5 + 5 = 10 + 10 + 10 + 10 + 10 + 10 + 10 + 10 + 10 + 10$
(b) $25 \times 8 = 4 \times 50$
(c) $970 - 930 = 470 - 430$
- (a) False (b) True (c) True
(d) True (e) True (f) False

UNIT

2

NUMBER SENTENCES

2.1 State addition and subtraction facts

The number 80 can be formed by adding up 8 tens:

$$10 + 10 \rightarrow 20 + 10 \rightarrow 30 + 10 \rightarrow 40 + 10 \rightarrow 50 + 10 \rightarrow 60 + 10 \rightarrow 70 + 10 = 80$$

The number 80 can also be formed by adding up 5 sixteens:

$$16 + 16 \rightarrow 32 + 16 \rightarrow 48 + 16 \rightarrow 64 + 16 = 80$$

We can say: "Adding up 8 tens gives the same result as adding up 5 sixteens".

A number sentence like this is called a **statement of equivalence**. The number sentence tells us that two *different actions* will produce the *same result*.

This number sentence can also be written in symbols:

$$10 + 10 + 10 + 10 + 10 + 10 + 10 + 10 = 16 + 16 + 16 + 16 + 16$$

$8 \times 10 = 5 \times 16$ is a shorter sentence that gives the same information.

- Write each number sentence in symbols.
 - Adding up 20 fives gives the same result as adding up 10 tens.
 - 25 times 8 gives the same result as 4 times 50.
 - The difference between 930 and 970 is the same as the difference between 430 and 470.
- Which of these number sentences are false?

"False" means not true.

 - $9 + 9 + 9 + 9 + 9 + 9 + 9 + 9 + 9 = 6 + 6 + 6 + 6 + 6 + 6$
 - $9 + 9 + 9 + 9 + 9 + 9 = 6 + 6 + 6 + 6 + 6 + 6 + 6 + 6 + 6$
 - $5 + 5 + 5 + 5 + 5 + 5 = 6 + 6 + 6 + 6 + 6$
 - $9 \times 6 = 6 \times 9$
 - $5 \times 6 = 6 \times 5$
 - $9 \times 9 = 6 \times 6$

When numbers are multiplied, any of the numbers can be taken first. The answer is the same.

Teaching guidelines

To be able to write and interpret statements of equivalence, learners need to know certain **basic conventions about order of operations** that are used in calculation plans. Without adhering to these conventions, different people may interpret the same calculation in different ways and confusion will result. This danger of confusion is demonstrated in the tinted passage.

You may do a presentation similar to the one in the tinted passage, or you could direct learners to read the tinted passage in their books, for example by asking: “*Why do Richard and Thandi look so confused?*” If learners have difficulties in reading the text, you may explain on the board why the two characters are so confused.

You may announce that while doing questions 3 to 7, they will learn about the agreements people have made to prevent such confusion. These five questions are interrelated and form a critical learning sequence. Ensure that learners read and understand the statements describing the different conventions, and illustrate these with more examples on the board.

Richard and Thandi had to calculate $12 - 3 + 5 - 2$ and $3 \times 10 + 5 \times 2$.
Richard worked like this:

$$\begin{array}{lll} 12 - 3 = 9 & 9 + 5 = 14 & 14 - 2 = 12 \\ 3 \times 10 = 30 & 30 + 5 = 35 & 35 \times 2 = 70 \end{array}$$

Thandi worked like this:

$$\begin{array}{lll} 3 + 5 = 8 & 12 - 8 = 4 & 4 - 2 = 2 \\ 3 \times 10 = 30 & 5 \times 2 = 10 & 30 + 10 = 40 \end{array}$$

Richard and Thandi were very confused when they compared their answers!



To avoid confusion like this, people all over the world follow certain agreements about instructions.

If instructions include only addition and subtraction, the calculations are done from left to right.

Example: $12 - 3 + 5 - 2$ means you have to do this:

$$12 - 3 = 9 \quad 9 + 5 = 14 \quad 14 - 2 = 12$$

If instructions include multiplication, all multiplications are done before additions and subtractions.

Examples: $3 \times 10 + 5 \times 2$ means you have to do this:

$$3 \times 10 = 30 \quad 5 \times 2 = 10 \quad 30 + 10 = 40$$

$3 \times 10 - 5 \times 2$ means you have to do this:

$$3 \times 10 = 30 \quad 5 \times 2 = 10 \quad 30 - 10 = 20$$

Possible misconceptions

Poor understanding of the meaning of brackets can cause confusion and misconceptions. Brackets are used in calculation plans to indicate that if you follow the given calculation plan, you should do the calculations inside the brackets first.

For example, if you execute the calculation plan $45 \times (10 + 5 + 2)$, you first calculate $10 + 5 + 2$, get the answer 17, and then multiply this by 45.

But if you have to find out how much $45 \times (10 + 5 + 2)$ is, you are free to replace it with the equivalent calculation plan $45 \times 10 + 45 \times 5 + 45 \times 2$, which gives $450 + 225 + 90 = 765$. Of course 45×17 gives the same answer.

Answers

3. (a) 12 (b) 13 (c) 39 (d) 27
4. False:
- (a) $100 - 50 + 30 \neq 100 - 80$
(b) $3 \times 10 + 5 \times 2 \neq 70$
(d) $3 \times 3 + 5 \times 3 \neq 8 \times 6$
5. False:
- (a) $12 - (3 + 5) - 2 \neq 12 - 3 + 5 - 2$
(b) $3 \times 30 + 5 \times 30 \neq 3 \times (30 + 5) \times 30$
(d) $5 \times (20 + 3) \neq 5 \times 20 + 3$

3. Calculate.
- (a) $12 - 3 + 5 - 2$ (b) $20 + 5 - 10 - 6 + 4$
(c) $10 + 5 \times 5 - 3 + 7$ (d) $10 + 5 \times 5 - 3 \times 5 + 7$
4. Which of these number sentences are false?
- (a) $100 - 50 + 30 = 100 - 80$
(b) $3 \times 10 + 5 \times 2 = 70$
(c) $3 \times 10 + 5 \times 2 = 40$
(d) $3 \times 3 + 5 \times 3 = 8 \times 6$
(e) $3 \times 3 + 5 \times 3 = 8 \times 3$
(f) $3 \times 30 + 5 \times 30 = 8 \times 30$
(g) $3 \times 30 + 5 \times 30 = 10 \times 30 - 2 \times 30$

Brackets are used to indicate that certain calculations should be done first.

Examples:

In $3 \times (4 + 6)$ the brackets are used to tell you that you must calculate like this:

$$4 + 6 = 10 \text{ followed by } 3 \times 10 = 30$$

The instructions $3 \times 4 + 6$ as well as $6 + 3 \times 4$ tell you that you should calculate like this:

$$3 \times 4 = 12 \text{ followed by } 12 + 6 = 18$$

$12 - (3 + 5) - 2$ means you have to do this:

$$3 + 5 = 8 \quad 12 - 8 = 4 \quad 4 - 2 = 2$$

5. Which of these number sentences are false?
- (a) $12 - (3 + 5) - 2 = 12 - 3 + 5 - 2$
(b) $3 \times 30 + 5 \times 30 = 3 \times (30 + 5) \times 30$
(c) $3 \times 30 + 5 \times 30 = (3 \times 30) + (5 \times 30)$
(d) $5 \times (20 + 3) = 5 \times 20 + 3$
(e) $5 \times (20 + 3) = 5 \times 20 + 5 \times 3$
(f) $5 \times (20 + 3) = 5 \times 18 + 5 \times 5$
(g) $5 \times (20 - 3) = 5 \times 20 - 5 \times 3$
(h) $(20 + 3) \times 5 = 20 \times 5 + 3 \times 5$

Teaching guidelines

The associative property of addition forms the logical foundation for the statements of equivalence used in addition and subtraction, and you may alert learners to this at this stage. (Unit 3, which follows the current unit, is about addition and subtraction.)

Answers

6. None are false.
7. False:
- (c) $500 + 300 - 200 \neq 500 + 200 - 300$
- (f) $(60 - 7) + (10 - 3) \neq (60 - 10) + (7 - 3)$
8. The first, third and last actions produce the same result:
- $6 \times 1\,000 = 60 \times 100$
- $60 \times 100 = 600 \times 10$
- $600 \times 10 = 6 \times 1\,000$
9. The following actions will produce the correct answer, which is 2 000:
- (a) 20×100
- (b) $20 \times 60 + 20 \times 3 + 20 \times 30 + 20 \times 7$
- (d) $20 \times 60 + 20 \times 40$
- Action (c) $20 \times 80 \times 3 + 20 \times 50 \times 7$ will not.

6. Which of these number sentences are false?

- (a) $(1 + 3) + (5 + 7) + 9 = 1 + (3 + 5) + (7 + 9)$
- (b) $(10 + 8) + 6 = (8 + 6) + 10$
- (c) $(10 + 8) + 6 = (6 + 10) + 8$

When more than two numbers have to be added, you can add any two of them first.

7. Which of these number sentences are false?

- (a) $500 + 300 + 200 = 200 + 500 + 300$
- (b) $500 + 300 + 200 = 500 + 200 + 300$
- (c) $500 + 300 - 200 = 500 + 200 - 300$
- (d) $20 + 10 - 5 = 20 - 5 + 10$
- (e) $(60 + 3) + (10 + 7) = (60 + 10) + (3 + 7)$
- (f) $(60 - 7) + (10 - 3) = (60 - 10) + (7 - 3)$
- (g) $(60 + 7) - (10 + 3) = (60 - 10) + (7 - 3)$

8. Which of the following actions will produce the same result?

Write your answer in the form of number sentences, for example $3 \times 6 = 2 \times 9$.

$6 \times 1\,000$ 60×10 60×100 600×10

9. Suppose you want to know how much $20 \times 63 + 20 \times 37$ is. Which of the following actions will produce the correct answer, and which will not?

- (a) 20×100
- (b) $20 \times 60 + 20 \times 3 + 20 \times 30 + 20 \times 7$
- (c) $20 \times 80 \times 3 + 20 \times 50 \times 7$
- (d) $20 \times 60 + 20 \times 40$

2.2 Solve and complete number sentences

Mathematical notes

Number sentences can be **open** or **closed**. The number sentence $3 \times (7 + 4) = 3 \times 7 + 3 \times 4$ is a closed number sentence; all the numbers are given.

$73 + \dots = 100$ or $73 + \square = 100$ is an open number sentence; it is incomplete. It contains an **unknown**. In algebra this is normally called an **equation**.

It is actually a question: $73 + ? = 100$. (Also see the “Mathematical notes” about symbols for unknowns on the next page of this Teacher Guide.)

A number sentence can also have only a number on one side of the equal sign, for example $3 \times 12 + 5 \times 12 = 96$ or $8 \times 12 = 96$. Number sentences like these are used to state **number facts**, for example $4 + 5 = 9$, and the **answers** for calculations that were done, for example $256 + 322 = 578$.

Teaching guidelines

This section starts by introducing the idea of open number sentences, and completing them by finding the missing number. Learners may engage with questions 1 and 2 straightaway, without any introduction from you.

Question 3 is about the use of number sentences to describe addition facts, and it provides opportunities for practice.

Answers

- 19
- | | | | |
|--------|--------|--------|--------|
| (a) 20 | (b) 19 | (c) 18 | (d) 15 |
| (e) 30 | (f) 40 | (g) 20 | (h) 20 |
| (i) 60 | (j) 50 | (k) 70 | (l) 80 |
| (m) 75 | (n) 25 | (o) 35 | (p) 12 |
- There are numerous possibilities and only a few examples are given below. All learners' answers should be considered.

(a) $80 + 20 = 100$	$75 + 25 = 100$	$91 + 9 = 100$
(b) $65 + 35 = 100$	$78 + 22 = 100$	$40 + 60 = 100$
(c) $56 + 44 = 100$	$85 + 15 = 100$	$71 + 29 = 100$
(d) $100 + 200 = 300$	$150 + 150 = 300$	$250 + 50 = 300$
(e) $500 + 200 = 700$	$450 + 250 = 700$	$145 + 555 = 700$

2.2 Solve and complete number sentences

- Which number is hidden behind the red stickers?

$$21 + \text{[red sticker]} = 40$$

- Write down the number that is hidden behind the red stickers in each number sentence.

- | | |
|---------------------------------------|---------------------------------------|
| (a) $30 + \text{[red sticker]} = 50$ | (b) $31 + \text{[red sticker]} = 50$ |
| (c) $32 + \text{[red sticker]} = 50$ | (d) $35 + \text{[red sticker]} = 50$ |
| (e) $30 + \text{[red sticker]} = 60$ | (f) $20 + \text{[red sticker]} = 60$ |
| (g) $40 + \text{[red sticker]} = 60$ | (h) $\text{[red sticker]} + 40 = 60$ |
| (i) $\text{[red sticker]} + 40 = 100$ | (j) $\text{[red sticker]} + 50 = 100$ |
| (k) $\text{[red sticker]} + 30 = 100$ | (l) $\text{[red sticker]} + 20 = 100$ |
| (m) $25 + \text{[red sticker]} = 100$ | (n) $75 + \text{[red sticker]} = 100$ |
| (o) $65 + \text{[red sticker]} = 100$ | (p) $88 + \text{[red sticker]} = 100$ |

- Choose any two numbers for the blue and yellow stickers. The two numbers together must make 100.

$$\text{[blue sticker]} + \text{[yellow sticker]} = 100$$

Write your answer as a number sentence, for example $90 + 10 = 100$.

- Write a different number sentence that shows two other numbers that add up to 100.
- Write any other ten different number sentences that each show two numbers that add up to 100.
- Write ten different number sentences that each show two numbers that add up to 300.
- Write ten different number sentences that each show two numbers that add up to 700.

Teaching guidelines

Apart from relating number sentences to the number line, questions 5 to 7 are about using number sentences to articulate the idea of addition and subtraction as inverse operations. It may be necessary to do question 6 as a demonstration on the board.

Questions 4 to 8 are questions for learning and hence critical.

Answers

4. The number behind the blue stickers is 85, because $85 + 3 = 88$.
So, when adding 5 to the number behind the blue stickers the answer will be 90.
5. (a) Yes (b) Yes
6. (a) $120 - 62 = 58$ (b) $120 - 58 = 62$
7. (a) 78 (b) 35
8. $35 + 85 = 120$
 $120 - 85 = 35$
 $120 - 35 = 85$

Mathematical notes

In algebra a letter symbol, for example x , is normally used to represent an unknown constant, for example $73 + x = 100$.

Symbols used to represent unknown constants (or variables), such as \dots or $?$ or \square or x , are called **placeholders**.

Instead of a symbol, the phrase *a number* or *the number* can also be used. The open number sentence $73 + \square = 100$ can thus also be written as $73 + \text{a number} = 100$.

4. When you add 3 to the number behind the blue stickers, the answer is 88.

$$\square + 3 = 88$$

What will the answer be if you add 5 to the number behind the same blue stickers?

$$\square + 5 = ?$$

5. Simanga worked out that $46 + 74 = 120$.
You can see in the diagram below that his answer is right.

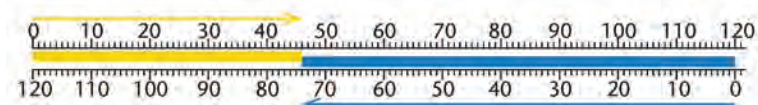

(a) Is it true that $120 - 74 = 46$?

(b) Is it true that $120 - 46 = 74$?

6. Look at the diagram below. It shows that $58 + 62 = 120$.
Complete these number sentences:

(a) $120 - 62 = \square$

(b) $120 - 58 = \square$

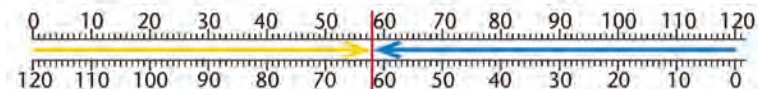

7. Nontobeko knows that $78 - 35 = 43$.

(a) How much is $43 + 35$?

(b) How much is $78 - 43$?

8. In question 5 you can read three number sentences that describe what the diagram shows.

Write three number sentences to describe what the diagram below shows.

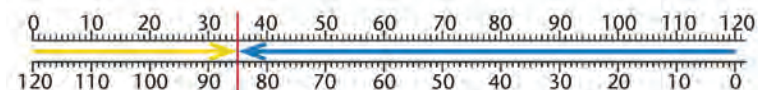

Notes on questions

Questions 9 to 12 are intended as practice of addition and subtraction bonds (Mental Mathematics).

Answers

9. There are numerous possibilities, for example:

$80 + 10 = 90$	$90 - 10 = 80$	$90 - 80 = 10$
$65 + 25 = 90$	$90 - 25 = 65$	$90 - 65 = 25$
$81 + 9 = 90$	$90 - 9 = 81$	$90 - 81 = 9$
$35 + 55 = 90$	$90 - 55 = 35$	$90 - 35 = 55$

10. There are numerous possibilities, for example:

$580 + 420 = 1\ 000$	$1\ 000 - 420 = 580$	$1\ 000 - 580 = 420$
$475 + 525 = 1\ 000$	$1\ 000 - 525 = 475$	$1\ 000 - 475 = 525$
$891 + 19 = 1\ 000$	$1\ 000 - 19 = 891$	$1\ 000 - 891 = 19$
$450 + 550 = 1\ 000$	$1\ 000 - 550 = 450$	$1\ 000 - 450 = 550$

11. There are numerous possibilities, for example:

(a) $250 + 150 + 200 = 600$	$175 + 125 + 300 = 600$
$450 + 125 + 25 = 600$	$130 + 370 + 100 = 600$
(b) $400 + 250 + 150 = 800$	$555 + 125 + 120 = 800$
$300 + 450 + 50 = 800$	$345 + 105 + 350 = 800$
(c) $750 + 150 + 100 = 1\ 000$	$480 + 220 + 300 = 1\ 000$
$505 + 245 + 250 = 1\ 000$	$870 + 115 + 15 = 1\ 000$

12. There are numerous possibilities, for example:

(a) $35 + 65 - 50 = 50$	$28 + 33 - 11 = 50$
$250 + 45 - 245 = 50$	$2 + 53 - 5 = 50$
(b) $400 + 467 - 667 = 200$	$55 + 315 - 170 = 200$
$900 + 11 - 711 = 200$	$45 + 165 - 10 = 200$
(c) $350 + 300 - 250 = 400$	$390 + 230 - 220 = 400$
$457 + 13 - 70 = 400$	$985 + 15 - 600 = 400$

9. $52 + 38 = 90$ $90 - 38 = 52$ $90 - 52 = 38$

You can see it in this diagram:



Write ten other addition number sentences that each show two numbers that add up to 90. For each addition number sentence also write two number sentences that state subtraction facts about 90.

10. Write ten addition number sentences that each show two numbers that add up to 1 000. For each addition number sentence also write two number sentences that state subtraction facts about 1 000.
11. The number sentence $100 + 200 + 300 = 600$ shows three numbers that add up to 600.
- Write three other number sentences that each show three numbers that add up to 600.
 - Write three number sentences that each show three numbers that add up to 800.
 - Write three number sentences that each show three numbers that add up to 1 000.
12. The number sentence $20 + 60 - 30 = 50$ shows how adding two numbers and subtracting a number can produce the answer 50.
- Write three other number sentences that each show how adding two numbers and subtracting a number can produce the answer 50.
 - Write three different number sentences that each show how adding two numbers and subtracting a number can produce the answer 200.
 - Write three different number sentences that each show how adding two numbers and subtracting a number can produce the answer 400.

2.3 Equivalence

Teaching guidelines

The purpose of this section is to develop the use of number sentences to make general statements of equivalence, specifically of the distributive property of multiplication. Note that learners need not know the names of the properties of multiplication (e.g. distributive property) in Grade 5.

The coloured stickers provide a way of making statements equivalent to $x \times (y + z) = x \times y + x \times z$ without using algebraic letter symbols.

Questions 1 and 2 may form the substance of an interactive whole-class discussion, whereafter learners do questions 3 and 4 individually. Questions 1 to 3 are critical questions for learning.

Answers

- (a) Learners choose their own numbers, therefore their answers will vary.
(b) Yes
- (a) No (b) Yes
- (a) Yes (b) Yes (c) Yes (d) No
- (a) False (b) True (c) True
(d) True (e) True

2.3 Equivalence

Choose a number to hide behind the blue stickers in question 1. It must be the same number for each of the blue stickers. Write your blue number down.

Also choose one number to put behind the yellow stickers. It must be same number for each of the yellow stickers. Write your yellow number down.

- (a) How much is your $\blacksquare + \blacksquare$?
(b) Is it true that $10 \times (\blacksquare + \blacksquare) = 10 \times \blacksquare + 10 \times \blacksquare$?
- (a) Do you think the other learners in the class chose the same numbers as you to hide behind the blue and yellow stickers in question 1?
(b) Do you think the other learners in the class also found that the number sentence in question 1(b) is true, although they may have chosen different numbers than you did?
- Choose two other numbers for your blue and yellow stickers.
(a) Is it again true that $10 \times (\blacksquare + \blacksquare) = 10 \times \blacksquare + 10 \times \blacksquare$?
(b) Is $5 \times (\blacksquare + \blacksquare) = 5 \times \blacksquare + 5 \times \blacksquare$?
(c) Choose a number to hide behind the red stickers below.
 $\blacksquare \times (\blacksquare + \blacksquare) = \blacksquare \times \blacksquare + \blacksquare \times \blacksquare$
Is this number sentence true?
(d) Is the number sentence below true?
 $\blacksquare \times (\blacksquare + \blacksquare) = \blacksquare \times \blacksquare + \blacksquare$
- In each case state whether you think the sentence is true or false.
(a) $5 \times (400 + 30 + 7) = 5 \times 400 + 30 + 7$
(b) $5 \times (400 + 30 + 7) = 5 \times 400 + 5 \times 30 + 5 \times 7$
(c) $5 \times (400 - 30 - 7) = 5 \times 400 - 5 \times 30 - 5 \times 7$
(d) $5 \times (400 + 60 + 8) = 10 \times (200 + 30 + 4)$
(e) $5 \times (400 + 60 + 8) = 20 \times (100 + 15 + 2)$

Learner Book Overview		
Sections in this unit	Content	Pages in Learner Book
3.1 Addition and subtraction facts	Mental Mathematics activities	21 to 23
3.2 Addition, subtraction and doubling	Mental Mathematics activities	24 to 27
3.3 Doubling and other ways to make facts	Mental Mathematics activities	28 to 32
3.4 Add and subtract multiples of 100 and 1 000	Mental Mathematics activities	33 to 34
3.5 Rounding off and compensating	Using rounding off and compensation to subtract	35 to 37
3.6 Use brackets to describe your thinking	Rearranging numbers to simplify addition and subtraction	37 to 39
3.7 Add and subtract 4-digit numbers	Calculate by breaking numbers down and building the answers up	40 to 41
3.8 Round off, estimate and solve problems	Rounding off to the nearest 100 and 1 000; solving word problems	42 to 44

CAPS time allocation	5 hours
CAPS page references	13 to 15 and 132 to 135

Mathematical background

Calculations with multi-digit numbers are done by breaking the task down into separate smaller tasks. For example, the single task $254 + 538$ can be broken down into smaller tasks, as follows:

Single task: $254 + 538 = (200 + 50 + 4) + (500 + 30 + 8)$ (The numbers are broken down into their place value parts.)

Three separate tasks: $= (200 + 500) + (50 + 30) + (4 + 8)$ (The rearrangement can be done because addition is commutative and associative.)

Learners can only use “break down, rearrange and build up” methods effectively if they know the addition and subtraction bonds for units, and for multiples of 10 and 100 well, or can quickly reconstruct these facts. The core strategy of replacing a given computational task by a combination of separate tasks can only work if the separate tasks are simpler, and in fact easy to do for learners. This can only be the case if learners are not challenged by tasks such as $200 + 500$, $50 + 30$ and $4 + 8$: the answers to such calculations should be readily available in learners’ minds, or learners should be able to find the answers quickly and easily. Unfortunately the majority of learners have inadequate knowledge of addition and subtraction bonds, and can only reconstruct addition and subtraction facts by drawing stripes and counting. In fact, it seems that many learners do not even try to remember addition facts like $5 + 7 = 12$, and adopt the **habit** to simply draw stripes and count. To overcome this habit, learners need to learn basic number facts and acquire skills to reconstruct basic number facts. Sections 3.1 to 3.4 provide for this.

Resources

A set of place value cards for each learner and five sets of large place value cards for teaching purposes (see Addendum, pages 394 to 411)

3.1 Addition and subtraction facts

Teaching guidelines

Questions 1, 8, 9 and 10 provide learners with opportunities to relate addition and subtraction to real-life situations. If learners find these questions challenging, suggest that they quickly make rough copies of the drawings so that they can fill in distances on the drawing to support their thinking. If learners make drawings, ensure that they do not waste time on trying to make the drawings accurate and realistic – the drawings should be done quickly since they only serve the purpose of supporting learners’ thinking about the situation.

Even learners who know that $70 + 30 = 100$ may be challenged by question 1(a) if they fail to visualise the situation clearly in their minds. You may support learners by making a copy of the drawing on the board and stating the given information and questions verbally, and by annotating the drawing.



If learners are challenged by question 1(b), it may help to point out that they need to use the answer to question 1(a).

Questions 2 and 3 provide for practice in Mental Mathematics.

Answers

- | | | |
|----------|-----------|-----------|
| (a) 70 m | (b) 270 m | (c) 300 m |
|----------|-----------|-----------|
- | | | |
|----------------------|----------------------|---------------------|
| (a) $40 + 60 = 100$ | (b) $80 + 20 = 100$ | (c) $50 + 50 = 100$ |
| (d) $10 + 90 = 100$ | (e) $100 - 50 = 50$ | (f) $100 - 80 = 20$ |
| (g) $100 - 60 = 40$ | (h) $100 - 70 = 30$ | (i) $100 - 90 = 10$ |
| (j) $30 + 70 = 100$ | (k) $100 - 30 = 70$ | (l) $100 - 40 = 60$ |
| (m) $400 - 30 = 370$ | (n) $700 - 40 = 660$ | |
- | | | |
|--------|---------|--------|
| (a) 60 | (b) 60 | (c) 40 |
| (d) 60 | (e) 440 | (f) 60 |

UNIT 3
WHOLE NUMBERS:
ADDITION AND SUBTRACTION

3.1 Addition and subtraction facts

- The blue flag and the red flag are exactly 100 m from each other, along a straight road. Mac walks along the road and he is now 30 m from the red flag.

(a) How far is Mac from the blue flag?

The blue flag is 200 m away from a shop along the road.

(b) How far is Mac from the shop?

(c) How far is the red flag from the shop?
- $30 + 70 = 100$

Write number sentences to state how much each of the following is.

(a) $40 + 60$	(b) $80 + 20$
(c) $50 + 50$	(d) $10 + 90$
(e) $100 - 50$	(f) $100 - 80$
(g) $100 - 60$	(h) $100 - 70$
(i) $100 - 90$	(j) $30 + 70$
(k) $100 - 30$	(l) $100 - 40$
(m) $400 - 30$	(n) $700 - 40$
- Write the numbers that will make the number sentences true.

(a) $40 + \square = 100$	(b) $100 - \square = 40$
(c) $100 - \square = 60$	(d) $440 + \square = 500$
(e) $500 - \square = 60$	(f) $500 - \square = 440$

GRADE 5: MATHEMATICS [TERM 1] 21

Notes on questions

The number lines are given as suggestions that learners **may** think about positions, distances and movements on the number lines when they do calculations. However, learners should not feel compelled to think in terms of number lines: *If learners can do the calculations and solve the number sentences easily without thinking of number lines, they should do so.*

Answers

- | | | | |
|---------------|-----------|------------|-----------|
| 4. (a) 1 000 | (b) 1 000 | (c) 1 000 | (d) 1 000 |
| 5. (a) 700 | (b) 700 | (c) 300 | (d) 300 |
| (e) 300 | (f) 300 | (g) 3 700 | (h) 3 700 |
| 6. (a) 300 | (b) 300 | (c) 5 700 | (d) 5 700 |
| 7. (a) 10 000 | (b) 2 000 | (c) 10 000 | (d) 8 000 |
| (e) 10 000 | (f) 7 000 | (g) 10 000 | (h) 4 000 |
| (i) 10 000 | (j) 5 000 | (k) 7 000 | (l) 3 000 |
| (m) 8 000 | (n) 3 000 | | |

Mathematical notes

To support thinking about the number sentence $300 + \square = 1\,000$, one may think of 300 and 1 000 as positions on the number line, and ask oneself how far one has to move from 300 to get to 1 000.

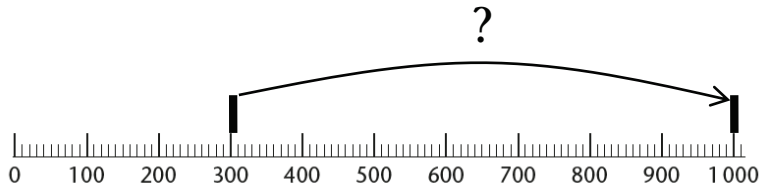

4. How much is each of the following?
 (a) $100 + 900$ (b) $500 + 500$
 (c) $200 + 800$ (d) $400 + 600$
5. Write the numbers that will make the number sentences true.
 (a) $300 + \square = 1\,000$ (b) $1\,000 - \square = 300$
 (c) $1\,000 - \square = 700$ (d) $700 + \square = 1\,000$
 (e) $3\,700 + \square = 4\,000$ (f) $4\,000 - \square = 3\,700$
 (g) $4\,000 - \square = 300$ (h) $300 + \square = 4\,000$

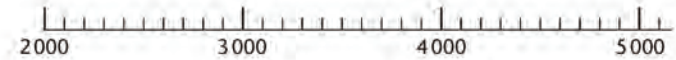

6. Write the numbers that will make the number sentences true.
 (a) $5\,700 + \square = 6\,000$ (b) $6\,000 - \square = 5\,700$
 (c) $6\,000 - \square = 300$ (d) $300 + \square = 6\,000$

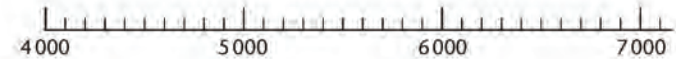

7. How much is each of the following?
 (a) $2\,000 + 8\,000$ (b) $10\,000 - 8\,000$
 (c) $8\,000 + 2\,000$ (d) $10\,000 - 2\,000$
 (e) $3\,000 + 7\,000$ (f) $10\,000 - 3\,000$
 (g) $4\,000 + 6\,000$ (h) $10\,000 - 6\,000$
 (i) $5\,000 + 5\,000$ (j) $10\,000 - 5\,000$
 (k) $3\,000 + 4\,000$ (l) $7\,000 - 4\,000$
 (m) $5\,000 + 3\,000$ (n) $8\,000 - 5\,000$

Teaching guidelines

Suggest to learners that if they have any difficulties with question 8, they could quickly make a rough drawing to help themselves to understand the situation. They should show the given distances on their drawings.

Some learners may indicate distances with arrows:



Other learners may mark the distances at specific points:

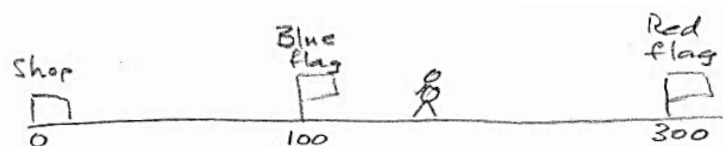

Note that drawings like these provide learners with an introduction to the number line.

Answers

8. (a) Approximately 120 m
 (b) Approximately 180 m
 (c) 300 m
 (d) 200 m
9. (a) 1 800 m
 (b) 2 600 m
 (c) 2 200 m
10. (a) 3 500 units
 (b) 4 600 units
 (c) 8 100 units

8. The blue flag is now 100 m away from the shop, and the red flag is 300 m away from the shop.



The shop

- (a) Approximately how far from the shop is Mac now?
 (b) Approximately how far from the red flag is Mac?
 (c) What should you get, if you add up your answers to questions (a) and (b)?
 (d) How far are the two flags apart in this case?
9. The blue flag is now 1 000 m away from the shop, the green flag is 2 000 m away and the red flag is 3 000 m away.

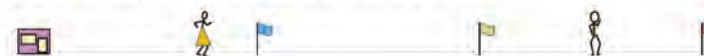

The shop

Sally, with the yellow dress, is 200 m away from the blue flag.

Mac is 400 m away from the red flag.

- (a) How far from Mac is Sally?
 (b) How far from the shop is Mac?
- If you think it may help you, you can make your own rough drawing of the situation. If you do, do not spend too much time on making the drawing. A rough drawing is all you need.
- (c) How far is Sally from the red flag?
10. (a) How far is the red flag from the blue flag on the number line?



- (b) How far is the red flag from the green flag?
 (c) How far is the green flag from the blue flag?

3.2 Addition, subtraction and doubling

Teaching guidelines

To help learners to read and make sense of the tinted passage, you may illustrate the ideas of **sum** and **difference** with drawings on the board, for example:

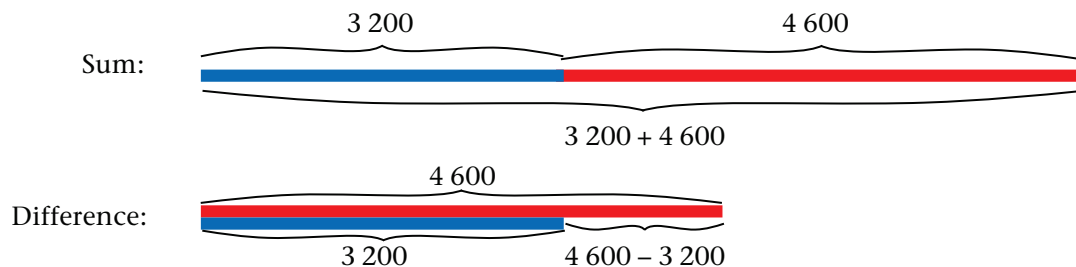

Note that in questions 1(a) and (b) learners have to calculate a sum and a difference respectively. Their responses to these questions can be used to assess the effectiveness of the introductory discussion.

Mathematical notes

Question 1 involves different meanings of subtraction.

In 1(b) subtraction is used to establish the **difference** between two amounts.

In 1(c) subtraction is used to establish a **shortfall**.

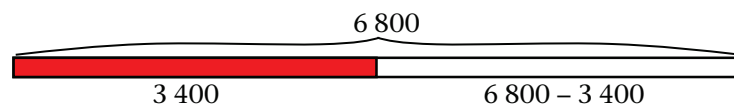

In 1(d) subtraction is used to establish how much is **left over** after some money was taken away from a given amount.

While learners usually know that they have to subtract in a situation like 1(d), they often do not realise that subtraction can be used in situations like 1(b) and 1(c). It is quite acceptable if learners do 1(c) like this:

$$3\ 400 + 600 \rightarrow 4\ 000 + 2\ 800 = 6\ 800, \text{ so he needs another } R600 + R2\ 800 = R3\ 400.$$

Notes on questions

Questions 1 and 2 are intended to make learners aware of how important it is that they have good knowledge of basic addition and subtraction facts for units and multiples of 10, 100 and 1 000. Discuss this in class to motivate learners for the work that follows.

Answers

- (a) R9 100 (b) R2 300 (c) R3 400 (d) R2 300
- 1 128 chickens

3.2 Addition, subtraction and doubling

Suppose you walk 3 200 m in the morning and 4 600 m in the afternoon.

To know how far you walked in total on that day you have to find the **sum** of the two numbers:

$$3\ 200 + 4\ 600 = 7\ 800$$

We can also say you **add** 4 600 to 3 200.

To know how much farther you walked in the afternoon than in the morning, you have to find the **difference** between the two numbers:

$$4\ 600 - 3\ 200 = 1\ 400$$

We can also say you **subtract** 3 200 from 4 600.

- Bongani is Tebogo's husband. They both work, and save regularly. Bongani has already saved R3 400 and Tebogo has saved R5 700.

(a) What is the total of Bongani's and Tebogo's savings?

(b) How much more than Bongani has Tebogo saved?

Bongani wants to buy a laptop computer for R6 800 from his savings. Tebogo says she will lend Bongani the money that he is short of.

(c) How much is Bongani short of what he needs to pay for the laptop computer?

(d) How much will Tebogo have left after she lends Bongani the money he needs?

- Mr Mudau is a farmer. He has to deliver 2 760 chickens to a big supermarket, but he has only 1 632 chickens ready for delivery. How many chickens is he short?

We often have to add and subtract to find the information that we need. That is why it is very important that you know the addition and subtraction facts for thousands, hundreds, tens and units very well.

Notes on questions

Learners are generally used to only doing calculations with, or stating facts about, numbers that are given to them. In question 3 they are required to state facts without any numbers given to them. Learners may need some encouragement and prompting to get started on this.

It is critical that learners acquire the habit of trying to be smart and to avoid doing unnecessary work. Question 4 provides an opportunity for this. Some learners may be inclined to answer the three questions by doing the full calculations. For example, they may do the following for question 4(a):

$$\begin{aligned}(400 + 30 + 2) + (100 + 60 + 8) &= (400 + 100) + (30 + 60) + (2 + 8) \\ &= 500 + 90 + 10 \\ &= 600\end{aligned}$$

If learners do this, demonstrate on the board that if you know that $432 + 165 = 597$, the answer for $432 + 168$ can quickly and easily be found by adding 3 to 597, because 168 is 3 more than 165. Use this as an opportunity to encourage learners to try to be smart when they do calculations, and challenge them to be smart when they do questions 4(b) and (c).

Also impress on learners that they need to be able to do calculations with small numbers quickly in order to make good progress in Mathematics. The questions that follow will give them opportunities to strengthen their knowledge and skills for adding and subtracting multiples of 10, 100 and 1 000.

Answers

3. Learners write down ten different addition facts as well as two subtraction facts together with each addition fact, for example:

$$\begin{array}{lll}3 + 5 = 8 & 8 - 3 = 5 & 8 - 5 = 3 \\ 40 + 20 = 60 & 60 - 20 = 40 & 60 - 40 = 20\end{array}$$

4. (a) 600
(b) 566
(c) 710
5. (a) 50 tins
(b) 500 sausages

3. Here are some addition and subtraction facts:

$$\begin{array}{lll}2 + 6 = 8 & 8 - 2 = 6 & 8 - 6 = 2 \\ 60 + 30 = 90 & 90 - 30 = 60 & 90 - 60 = 30\end{array}$$

Write ten other addition facts that you know.

Write two subtraction facts together with each addition fact.

4. Moshanke knows that $432 + 165 = 597$.
Moshanke also knows that 168 is 3 more than 165.

- (a) How much is $432 + 168$?
(b) $324 + 239 = 563$
How much is $327 + 239$?
(c) $541 + 165 = 706$
How much is $545 + 165$?

5. Here are two red boxes and three yellow boxes.

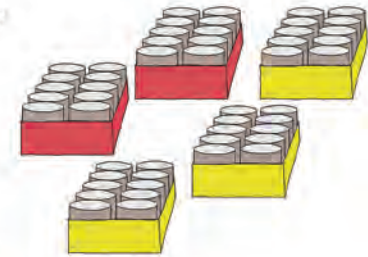

Each box contains 10 tins of Vienna sausages.

- (a) How many tins are there in all the boxes together?

There are 10 sausages in each tin.

- (b) How many sausages are there in all five boxes together?



Each box has 10 tins.



Each tin has 10 Vienna sausages.

Teaching guidelines

Point out to learners that each row of the picture represents several number facts.

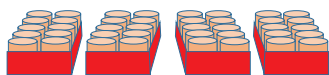

The above picture shows that 2 boxes + 2 boxes = 4 boxes, i.e. that $2 + 2 = 4$.

It also shows that 20 tins + 20 tins = 40 tins, i.e. that $20 + 20 = 40$.

If each tin contains 10 sausages, the picture also shows that 200 sausages + 200 sausages = 400 sausages.

Answers

6. (a) 20 tins (b) 40 tins (c) 60 tins (d) 80 tins
7. $3 + 3 = 6$ $30 + 30 = 60$ $300 + 300 = 600$
 $4 + 4 = 8$ $40 + 40 = 80$ $400 + 400 = 800$
 $5 + 5 = 10$ $50 + 50 = 100$ $500 + 500 = 1\ 000$
 $6 + 6 = 12$ $60 + 60 = 120$ $600 + 600 = 1\ 200$
 $7 + 7 = 14$ $70 + 70 = 140$ $700 + 700 = 1\ 400$
 $8 + 8 = 16$ $80 + 80 = 160$ $800 + 800 = 1\ 600$
 $9 + 9 = 18$ $90 + 90 = 180$ $900 + 900 = 1\ 800$
 $10 + 10 = 20$ $100 + 100 = 200$ $1\ 000 + 1\ 000 = 2\ 000$
 $11 + 11 = 22$ $110 + 110 = 220$ $1\ 100 + 1\ 100 = 2\ 200$
8. (a) 350 (b) 400 (c) 500
(d) 250 (e) 125 (f) 150
9. (a) 200 sausages (b) 400 sausages (c) 600 sausages (d) 800 sausages

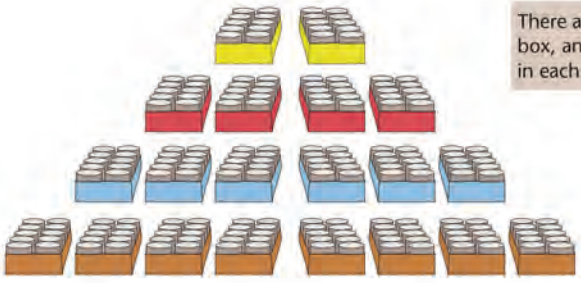

6. (a) How many tins are in the yellow boxes shown above?
(b) How many tins are in the red boxes?
(c) How many tins are in the blue boxes?
(d) How many tins are in the brown boxes?

Doubling is an easy way to make addition facts.
For example, it is easy to double 30:
 $30 + 30 = 60$
We can say: **60 is the double of 30.**

7. Write number sentences to state the doubles of the numbers below.
Example: $3 + 3 = 6$; $30 + 30 = 60$; $300 + 300 = 600$

3	4	5	6	7	8	9	10	11
30	40	50	60	70	80	90	100	110
300	400	500	600	700	800	900	1 000	1 100

8. 300 is half of 600. How much is half of each number below?
(a) 700 (b) 800 (c) 1 000
(d) 500 (e) 250 (f) 300

9. (a) How many sausages are in the yellow boxes above?
(b) How many sausages are in the red boxes?
(c) How many sausages are in the blue boxes?
(d) How many sausages are in the brown boxes?

26 UNIT 3: WHOLE NUMBERS: ADDITION AND SUBTRACTION

Answers

10. (a) 200 tins
 (b) 2 000 sausages
11. $10 + 12 + 14 + 16 + 20 = 72$ boxes \rightarrow 720 tins \rightarrow 7 200 sausages
12. (a) 70 (b) 60 (c) 80 (d) 90 (e) 40
 (f) 50 (g) 80 (h) 70 (i) 60 (j) 90

Possibilities for extension

Doubles can be used as starting points for making other number facts, as suggested by the pictures below.

- $4 + 4 = 8$ (boxes)
 $40 + 40 = 80$ (tins)
 $400 + 400 = 800$ (sausages)

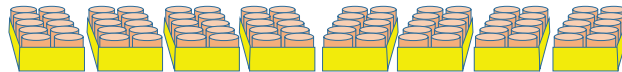

$40 - 10 + 40 = 30 + 40$ $80 - 10 = 70$

- $3 + 4 = 7$
 $30 + 40 = 70$
 $300 + 400 = 700$

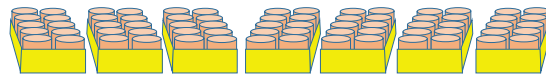

- $3 + 5 = 8$
 $30 + 50 = 80$
 $300 + 500 = 800$

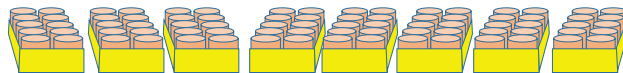

Suppose each sausage contains 10 g protein.
 How much protein is in a tin of 10 sausages?
 How much protein is in a box of 10 tins?

10. (a) How many tins are there altogether in all the boxes in the picture above question 6?
 (b) How many sausages are there altogether in all the tins in the picture above question 6?
11. How many sausages are there altogether in the tins below?

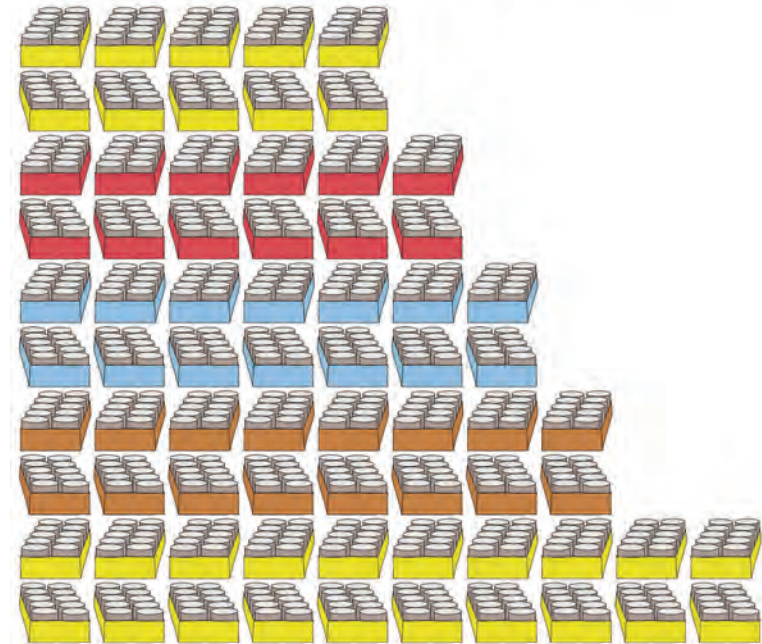

12. How much is each of the following?
- (a) $140 - 70$ (b) $140 - 80$
 (c) $140 - 60$ (d) $140 - 50$
 (e) $140 - 100$ (f) $140 - 90$
 (g) $160 - 80$ (h) $160 - 90$
 (i) $160 - 100$ (j) $180 - 90$

3.3 Doubling and other ways to make facts

Critical knowledge and skills

It is critical that learners acquire skills to reconstitute basic addition and subtraction facts that they may have forgotten, and not rely on drawing stripes and counting.

Doubling numbers and extending from doubles is a powerful way of forming addition facts. For example, if you know that $60 + 60 = 120$, it is easy to form other facts by performing easy additions or subtractions on both sides of the equal sign:

$$60 + 60 + 10 = 120 + 10, \text{ hence } 60 + 70 = 130$$

$$60 + 60 - 10 = 120 - 10, \text{ hence } 60 + 50 = 110$$

Answers

- (a) 11 (b) 17 (c) 18
(d) 21 (e) 18 (f) 15
- 600 1 200 800
1 000 1 600 400
1 400 1 800 2 000
50 150 70
- (Learners may phrase their explanations in different ways.)
 $60 + 60 = 120$, and 90 is 30 more than 60.
So $60 + 90$ is $120 + 30$, which is 150.
- (a) $75 + 75 + 4 \rightarrow 150 + 4 = 154$ (or phrased like above)
(b) $400 + 400 + 300 \rightarrow 800 + 300 = 1 100$
(c) $60 + 60 + 30 \rightarrow 120 + 30 = 150$
(d) $50 + 50 + 40 \rightarrow 100 + 40 = 140$

Teaching guidelines

It may be valuable to share the following idea with learners:

What to do when you do not know an addition fact

Suppose you do not know how much $30 + 50$ is.

You can double the smaller number: $30 + 30 = 60$

Can this help you to know how much $30 + 50$ is?

3.3 Doubling and other ways to make facts

- How much is each of the following?
(a) 3 more than 8 (b) 5 more than 12
(c) 2 more than 16 (d) 3 more than 18
(e) 4 more than 14 (f) 1 more than 14
- How much is each of the following?

$300 + 300$	$600 + 600$	$400 + 400$
$500 + 500$	$800 + 800$	$200 + 200$
$700 + 700$	$900 + 900$	$1\ 000 + 1\ 000$
$25 + 25$	$75 + 75$	$35 + 35$

You have to be able to make a plan when you do not quickly know the answer to a simple addition or subtraction question. One of the things you can do is to use your knowledge of doubles.

For example, you may not know immediately how much $70 + 80$ is. But if you know that $70 + 70 = 140$, you can add 10 and then you know that $70 + 80 = 150$.

If you do not quickly know how much $25 + 28$ is, your knowledge that $25 + 25 = 50$ can help you, for example like this:

28 is 3 more than 25, so $25 + 28$ is 3 more than $25 + 25$.

So, $25 + 28 = 50 + 3 = 53$.

If you do not know how much $40 + 70$ is, your knowledge that $40 + 40 = 80$ can help you like this:

Because 70 is 30 more than 40, $40 + 70$ is 30 more than $40 + 40$, so $40 + 70$ is $80 + 30$, which is 110.

- Explain how doubling 60 can be used to find out how much $60 + 90$ is. Write your explanation clearly, so that someone else can easily understand you.
- Explain how doubling can be used to find the answer to each of the following.
(a) $75 + 79$ (b) $400 + 700$
(c) $60 + 90$ (d) $50 + 90$

Teaching guidelines

Like all the other work in this section, question 5 is a Mental Mathematics activity. It provides learners with an opportunity to self-assess their knowledge of simple addition and subtraction facts. Learners have to identify the number sentences for which they cannot give the answers quickly and easily, and write them down. Tell learners that the activities that follow may help them to learn how to find the answers quickly and easily. They will then revisit these number sentences when they do question 7 on page 31 of the Learner Book.

Answers

5.

$9 + 6 = 15$	$7 + 6 = 13$	$7 + 8 = 15$
$900 + 600 = 1\ 500$	$700 + 600 = 1\ 300$	$700 + 800 = 1\ 500$
$1\ 500 - 600 = 900$	$1\ 300 - 700 = 600$	$1\ 500 - 800 = 700$
$60 + 60 = 120$	$80 + 50 = 130$	$700 + 700 = 1\ 400$
$50 + 80 = 130$	$40 + 90 = 130$	$30 + 100 = 130$
$130 - 50 = 80$	$130 - 40 = 90$	$1\ 300 - 300 = 1\ 000$
$13 - 8 = 5$	$13 - 9 = 4$	$12 - 3 = 9$
$170 - 60 = 110$	$18 - 6 = 12$	$13 - 6 = 7$
$15 - 8 = 7$	$150 - 70 = 80$	$110 - 60 = 50$
$16 - 8 = 8$	$16 - 7 = 9$	$1\ 100 - 500 = 600$
$180 - 90 = 90$	$18 - 8 = 10$	$140 - 60 = 80$
$17 - 8 = 9$	$600 + 900 = 1\ 500$	$170 - 90 = 80$
$9 + 8 = 17$	$7 + 9 = 16$	$70 + 40 = 110$
$900 + 800 = 1\ 700$	$700 + 900 = 1\ 600$	$700 + 400 = 1\ 100$
$1\ 700 - 600 = 1\ 100$	$1\ 600 - 700 = 900$	$1\ 100 - 400 = 700$

5. Copy the open number sentences for which you *cannot* give the answers quickly. You will work on them later.

$9 + 6 = \dots$	$7 + 6 = \dots$	$7 + 8 = \dots$
$900 + 600 = \dots$	$700 + 600 = \dots$	$700 + 800 = \dots$
$1\ 500 - 600 = \dots$	$1\ 300 - 700 = \dots$	$1\ 500 - 800 = \dots$
$60 + 60 = \dots$	$80 + 50 = \dots$	$700 + 700 = \dots$
$50 + 80 = \dots$	$40 + 90 = \dots$	$30 + 100 = \dots$
$130 - 50 = \dots$	$130 - 40 = \dots$	$1\ 300 - 300 = \dots$
$13 - 8 = \dots$	$13 - 9 = \dots$	$12 - 3 = \dots$
$170 - 60 = \dots$	$18 - 6 = \dots$	$13 - 6 = \dots$
$15 - 8 = \dots$	$150 - 70 = \dots$	$110 - 60 = \dots$
$16 - 8 = \dots$	$16 - 7 = \dots$	$1\ 100 - 500 = \dots$
$180 - 90 = \dots$	$18 - 8 = \dots$	$140 - 60 = \dots$
$17 - 8 = \dots$	$600 + 900 = \dots$	$170 - 90 = \dots$
$9 + 8 = \dots$	$7 + 9 = \dots$	$70 + 40 = \dots$
$900 + 800 = \dots$	$700 + 900 = \dots$	$700 + 400 = \dots$
$1\ 700 - 600 = \dots$	$1\ 600 - 700 = \dots$	$1\ 100 - 400 = \dots$

Here is a way to see that $8 + 6 = 14$:

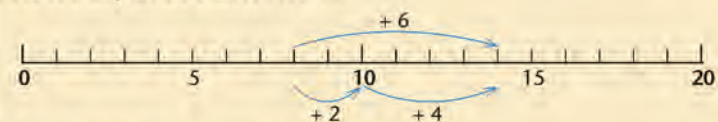

6 can be added to 8 in two steps:

$8 + 2 = 10$ followed by $10 + 4 = 14$.

We can write as follows to show this thinking:

$8 + 2 \rightarrow 10 + 4 = 14$.

You can also think of a number line to know how much $800 + 600$ is:

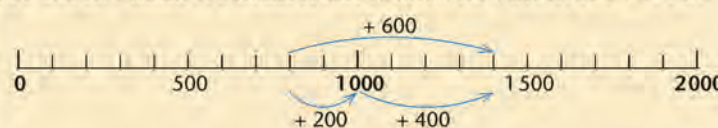

Mathematical notes

The tinted passage is not just about different ways of representing subtraction on the number line. The passage describes three ways of thinking about subtraction (three “meanings” of subtraction):

- subtraction as finding the difference between two numbers
- subtraction as filling up a gap between two quantities (addressing a shortfall)
- subtraction as taking something away from a given quantity.

When learners have to engage with an “abstract” subtraction question (no context) such as “How much is $1\,500 - 700$?”, they can interpret the question in any of the three ways – it becomes a choice between three methods of subtraction.

Answers

6. (a) $50 + 80 = 130$ $130 - 50 = 80$ $130 - 80 = 50$
 (b) $500 + 800 = 1\,300$ $1\,300 - 800 = 500$ $1\,300 - 500 = 800$
 (c) $7 + 7 = 14$ $14 - 7 = 7$
 (d) $70 + 70 = 140$ $140 - 70 = 70$

To find out how much $1\,500 - 700$ is, it may help to ask yourself what the **difference** between the two numbers is.



Another way is to ask yourself what you need to add to the smaller number to reach the bigger number.

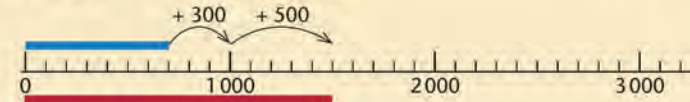

This thinking can be shown as follows:

$$700 + 300 \rightarrow 1\,000 + 500 = 1\,500$$

The above number line diagram shows an **addition fact** and **two subtraction facts**:

$$700 + 800 = 1\,500 \quad 1\,500 - 700 = 800 \quad 1\,500 - 800 = 700$$

You may also think of moving backwards on the number line:



This thinking can also be shown like this:

$$1\,500 - 500 \rightarrow 1\,000 - 300 = 700$$

6. Write the addition fact and the two subtraction facts that are shown by each number line diagram.

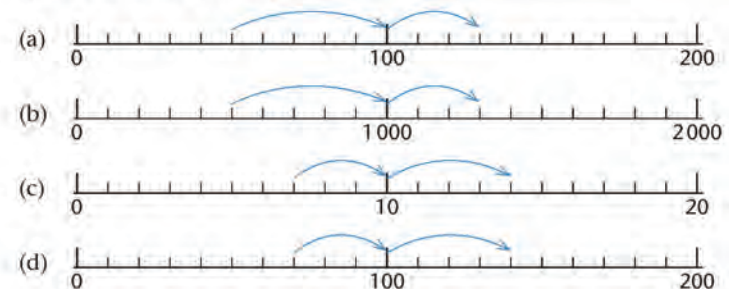

Teaching guidelines

Ensure that learners feel free to use any method they prefer when they do question 8. They should not feel obliged to use the number line. Ideally, they should be able to write most of the answers straightaway without even thinking about it.

Answers

7. Refer to question 5, two pages back.

8. (a) 150 (b) 1 500 (c) 70 (d) 80
(e) 800 (f) 700 (g) 90 (h) 900
(i) 9 000 (j) 9 000 (k) 130 (l) 1 300
(m) 600 (n) 1 500 (o) 1 400 (p) 600
(q) 600 (r) 2 200
9. (a) $350 + 80 = 430$ $430 - 80 = 350$ $430 - 350 = 80$
(b) $550 + 80 = 630$ $630 - 80 = 550$ $630 - 550 = 80$
(c) $1\,350 + 80 = 1\,430$ $1\,430 - 80 = 1\,350$ $1\,430 - 1\,350 = 80$
(d) $6\,950 + 80 = 7\,030$ $7\,030 - 80 = 6\,950$ $7\,030 - 6\,950 = 80$
(e) $6\,500 + 800 = 7\,300$ $7\,300 - 800 = 6\,500$ $7\,300 - 6\,500 = 800$
(f) $3\,930 + 90 = 4\,020$ $4\,020 - 90 = 3\,930$ $4\,020 - 3\,930 = 90$

7. Go to the number sentences which you copied in question 5. Try to find answers for them without counting.

8. How much is each of the following?

- (a) $70 + 80$ (b) $700 + 800$
(c) $150 - 80$ (d) $150 - 70$
(e) $1\,500 - 700$ (f) $1\,500 - 800$
(g) $40 + 50$ (h) $400 + 500$
(i) $4\,000 + 5\,000$ (j) $5\,000 + 4\,000$
(k) $70 + 60$ (l) $700 + 600$
(m) $1\,300 - 700$ (n) $900 + 600$
(o) $600 + 800$ (p) $1\,500 - 900$
(q) $1\,400 - 800$ (r) $3\,000 - 800$

9. Write the addition fact and the two subtraction facts that are shown by each number line diagram.

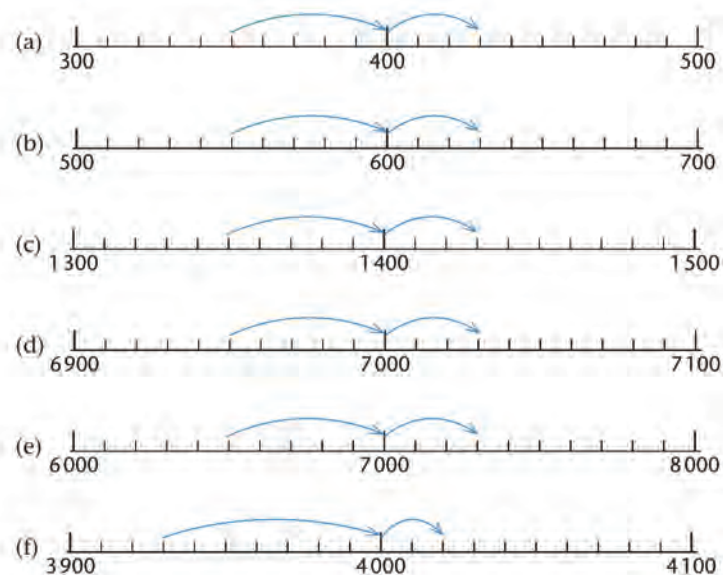

Answers

10. and 11.

$160 - 100 = 60$	$160 - 40 = 120$	$160 - 30 = 130$
$100 - 80 = 20$	$180 - 50 = 130$	$180 - 70 = 110$
$180 - 90 = 90$	$180 - 80 = 100$	$180 - 60 = 120$
$180 - 100 = 80$	$80 - 40 = 40$	$80 - 30 = 50$
$100 - 30 = 70$	$130 - 80 = 50$	$130 - 70 = 60$
$130 - 90 = 40$	$130 - 30 = 100$	$130 - 60 = 70$
$130 - 100 = 30$	$130 - 40 = 90$	$130 - 50 = 80$
$100 - 20 = 80$	$120 - 80 = 40$	$120 - 70 = 50$
$120 - 90 = 30$	$120 - 20 = 100$	$120 - 60 = 60$
$120 - 100 = 20$	$120 - 40 = 80$	$120 - 30 = 90$
$100 - 50 = 50$	$150 - 80 = 70$	$150 - 70 = 80$
$150 - 90 = 60$	$150 - 50 = 100$	$150 - 60 = 90$
$150 - 100 = 50$	$150 - 40 = 110$	$50 - 30 = 20$
$100 - 70 = 30$	$170 - 80 = 90$	$170 - 90 = 80$
$90 - 70 = 20$	$170 - 70 = 100$	$170 - 60 = 110$
$170 - 100 = 70$	$70 - 40 = 30$	$70 - 30 = 40$
$100 - 40 = 60$	$140 - 80 = 60$	$140 - 70 = 70$
$140 - 90 = 50$	$140 - 40 = 100$	$140 - 60 = 80$
$140 - 100 = 40$	$140 - 90 = 50$	$140 - 30 = 110$
$100 - 90 = 10$	$190 - 80 = 110$	$190 - 70 = 120$
$190 - 90 = 100$	$190 - 20 = 170$	$190 - 60 = 130$
$190 - 100 = 90$	$190 - 40 = 150$	$190 - 30 = 160$
$100 - 60 = 40$	$160 - 80 = 80$	$160 - 70 = 90$
$160 - 90 = 70$	$160 - 60 = 100$	$160 - 50 = 110$

10. Copy the number sentences for which you *cannot* find the answers quickly.

$160 - 100 = \dots$	$160 - 40 = \dots$	$160 - 30 = \dots$
$100 - 80 = \dots$	$180 - 50 = \dots$	$180 - 70 = \dots$
$180 - 90 = \dots$	$180 - 80 = \dots$	$180 - 60 = \dots$
$180 - 100 = \dots$	$80 - 40 = \dots$	$80 - 30 = \dots$
$100 - 30 = \dots$	$130 - 80 = \dots$	$130 - 70 = \dots$
$130 - 90 = \dots$	$130 - 30 = \dots$	$130 - 60 = \dots$
$130 - 100 = \dots$	$130 - 40 = \dots$	$130 - 50 = \dots$
$100 - 20 = \dots$	$120 - 80 = \dots$	$120 - 70 = \dots$
$120 - 90 = \dots$	$120 - 20 = \dots$	$120 - 60 = \dots$
$120 - 100 = \dots$	$120 - 40 = \dots$	$120 - 30 = \dots$
$100 - 50 = \dots$	$150 - 80 = \dots$	$150 - 70 = \dots$
$150 - 90 = \dots$	$150 - 50 = \dots$	$150 - 60 = \dots$
$150 - 100 = \dots$	$150 - 40 = \dots$	$50 - 30 = \dots$
$100 - 70 = \dots$	$170 - 80 = \dots$	$170 - 90 = \dots$
$90 - 70 = \dots$	$170 - 70 = \dots$	$170 - 60 = \dots$
$170 - 100 = \dots$	$70 - 40 = \dots$	$70 - 30 = \dots$
$100 - 40 = \dots$	$140 - 80 = \dots$	$140 - 70 = \dots$
$140 - 90 = \dots$	$140 - 40 = \dots$	$140 - 60 = \dots$
$140 - 100 = \dots$	$140 - 90 = \dots$	$140 - 30 = \dots$
$100 - 90 = \dots$	$190 - 80 = \dots$	$190 - 70 = \dots$
$190 - 90 = \dots$	$190 - 20 = \dots$	$190 - 60 = \dots$
$190 - 100 = \dots$	$190 - 40 = \dots$	$190 - 30 = \dots$
$100 - 60 = \dots$	$160 - 80 = \dots$	$160 - 70 = \dots$
$160 - 90 = \dots$	$160 - 60 = \dots$	$160 - 50 = \dots$

11. Now complete the sentences you have copied in question 10. You may work from the facts that you know or work in any other way you prefer.

3.4 Add and subtract multiples of 100 and 1 000

Teaching guidelines

Work through the tinted passage with learners. Make them aware that filling up to the nearest 100 or 1 000 makes the subtraction calculations simpler and easier.

Answers

- $3\ 600 + 400 \rightarrow 4\ 000 + 1\ 300 = 5\ 300$
 $5\ 300 - 1\ 700 = 3\ 600$ and $5\ 300 - 3\ 600 = 1\ 700$
 - $3\ 800 + 200 \rightarrow 4\ 000 + 400 = 4\ 400$
 $4\ 400 - 600 = 3\ 800$ and $4\ 400 - 3\ 800 = 600$
 - $3\ 500 + 500 \rightarrow 4\ 000 + 400 = 4\ 400$
 $4\ 400 - 900 = 3\ 500$ and $4\ 400 - 3\ 500 = 900$
 - $3\ 700 + 300 \rightarrow 4\ 000 + 1\ 300 = 5\ 300$
 $5\ 300 - 1\ 600 = 3\ 700$ and $5\ 300 - 3\ 700 = 1\ 600$
- $3\ 700 + \underline{300} \rightarrow 4\ 000 + \underline{4\ 200} = 8\ 200$
 $8\ 200 - 3\ 700 = \underline{4\ 500}$ (from $\underline{300} + \underline{4\ 200}$)
- $2\ 700 + \underline{300} \rightarrow 3\ 000 + \underline{3\ 500} = 6\ 500$
 So, $6\ 500 - 2\ 700 = 3\ 800$ (from $\underline{300} + \underline{3\ 500}$)
 and $3\ 800 + \underline{200} \rightarrow 4\ 000 + \underline{2\ 500} = 6\ 500$
 So, $6\ 500 - 3\ 800 = 2\ 700$ (from $\underline{200} + \underline{2\ 500}$)

3.4 Add and subtract multiples of 100 and 1 000

To calculate $5\ 700 + 1\ 800$ you may fill up to 6 000:

$$300 + 1\ 500 = 1\ 800$$

$$5\ 700 + 300 \rightarrow 6\ 000 + 1\ 500 = 7\ 500$$

When you know that $5\ 700 + 1\ 800 = 7\ 500$, you also know that $7\ 500 - 1\ 800 = 5\ 700$ and that $7\ 500 - 5\ 700 = 1\ 800$.

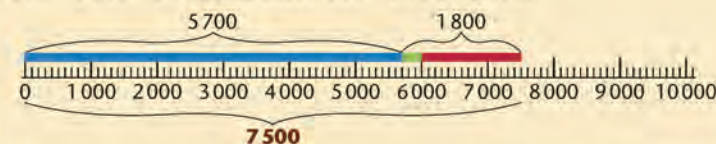

- Show how filling up to 4 000 can be used to calculate each of the following. In each case write two subtraction facts as well.
 - $3\ 600 + 1\ 700$
 - $3\ 800 + 600$
 - $3\ 500 + 900$
 - $3\ 700 + 1\ 600$

To calculate $8\ 200 - 3\ 700$, you may ask yourself how much should be added to 3 700 to get 8 200:

$$3\ 700 + ? = 8\ 200$$

To make it easier to answer this question, you can start by filling up to 4 000:

$$3\ 700 + ? \rightarrow 4\ 000 + ? = 8\ 200$$

- Find the missing numbers:
 $3\ 700 + ? \rightarrow 4\ 000 + ? = 8\ 200$,
 and use them to find the answer for $8\ 200 - 3\ 700$.
- Calculate $6\ 500 - 2\ 700$ and $6\ 500 - 3\ 800$.

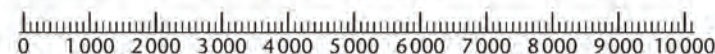

Answers

- (a) 5 000
(b) 5 000
(c) 5 000
- Learners check and correct their answers.
- Learners copy the number sentences for which they *cannot* find the answers quickly.
- Learners complete their copied number sentences in any way they prefer.

$360 - 80 = 280$	$360 + 90 = 450$	$760 - 670 = 90$
$560 - 480 = 80$	$680 + 70 = 750$	$430 - 270 = 160$
$380 - 90 = 290$	$780 + 80 = 860$	$780 - 60 = 720$
$720 - 50 = 670$	$770 + 40 = 810$	$940 - 70 = 870$
$810 - 730 = 80$	$330 + 80 = 410$	$670 - 90 = 580$

$3\ 200 - 900 = 2\ 300$	$2\ 300 + 900 = 3\ 200$
$6\ 700 - 500 = 6\ 200$	$3\ 500 + 800 = 4\ 300$
$4\ 500 - 900 = 3\ 600$	$3\ 600 + 900 = 4\ 500$
$8\ 400 + 800 = 9\ 200$	$9\ 200 - 800 = 8\ 400$
$9\ 200 - 8\ 400 = 800$	$5\ 500 + 700 = 6\ 200$
$6\ 200 - 700 = 5\ 500$	$6\ 200 - 5\ 500 = 700$
$7\ 200 - 700 = 6\ 500$	$7\ 200 - 800 = 6\ 400$
$7\ 300 - 800 = 6\ 500$	$7\ 400 - 900 = 6\ 500$

- How much is each of the following? If it will help you, you may think of movements on the number line.

- $1\ 700 + 900 + 700 + 800 + 900$
- $800 + 500 + 900 + 400 + 800 + 700 + 900$
- $1\ 900 + 600 + 800 + 800 + 500 + 400$



- Your answers for questions 4(a), (b) and (c) should be the same. If they are not, you have made mistakes. Find and correct your mistakes.
- Copy the number sentences for which you *cannot* find the answers quickly.

$360 - 80 = \dots$	$360 + 90 = \dots$	$760 - 670 = \dots$
$560 - 480 = \dots$	$680 + 70 = \dots$	$430 - 270 = \dots$
$380 - 90 = \dots$	$780 + 80 = \dots$	$780 - 60 = \dots$
$720 - 50 = \dots$	$770 + 40 = \dots$	$940 - 70 = \dots$
$810 - 730 = \dots$	$330 + 80 = \dots$	$670 - 90 = \dots$

$3\ 200 - 900 = \dots$	$2\ 300 + 900 = \dots$
$6\ 700 - 500 = \dots$	$3\ 500 + 800 = \dots$
$4\ 500 - 900 = \dots$	$3\ 600 + 900 = \dots$
$8\ 400 + 800 = \dots$	$9\ 200 - 800 = \dots$
$9\ 200 - 8\ 400 = \dots$	$5\ 500 + 700 = \dots$
$6\ 200 - 700 = \dots$	$6\ 200 - 5\ 500 = \dots$
$7\ 200 - 700 = \dots$	$7\ 200 - 800 = \dots$
$7\ 300 - 800 = \dots$	$7\ 400 - 900 = \dots$

- Now complete the number sentences that you have copied in question 6. You may work from the facts that you know or work in any other way you prefer.

3.5 Rounding off and compensating

Teaching guidelines

Use the tinted passages to make learners aware of various ways to do subtraction. You can do some more examples with different numbers on the board.

Answers

1. Any one of the following:

$$3\ 756 + \underline{244} \rightarrow 4\ 000 + \underline{1\ 254} = 5\ 254$$

$$\text{So, } 5\ 254 - 3\ 756 \rightarrow \underline{244} + \underline{1\ 254} = 1\ 498$$

or

$$3\ 756 + \underline{44} \rightarrow 3\ 800 + \underline{200} \rightarrow 4\ 000 + \underline{1\ 254} = 5\ 254$$

$$\text{So, } 5\ 254 - 3\ 756 \rightarrow \underline{44} + \underline{200} + \underline{1\ 254} = 1\ 498$$

or

$$3\ 756 + \underline{4} \rightarrow 3\ 760 + \underline{40} \rightarrow 3\ 800 + \underline{200} \rightarrow 4\ 000 + \underline{1\ 254} = 5\ 254$$

$$\text{So, } 5\ 254 - 3\ 756 \rightarrow \underline{4} + \underline{40} + \underline{200} + \underline{1\ 254} = 1\ 498$$

2. (a) 3 643
(b) 4 628
(c) 3 694
(d) 5 326
3. (a) $8\ 000 - 3\ 000 = 5\ 000$
 $800 - 200 = 600$
 $50 - 40 = 10$
 $6 - 3 = 3$
 $5\ 000 + 600 + 10 + 3 = 5\ 613$
So, $8\ 856 - 3\ 243 = 5\ 613$
- (b) $6\ 000 - 1\ 000 = 5\ 000$
 $800 - 500 = 300$
 $70 - 40 = 30$
 $6 - 2 = 4$
 $5\ 000 + 300 + 30 + 4 = 5\ 334$
So, $6\ 876 - 1\ 542 = 5\ 334$

3.5 Rounding off and compensating

To calculate $5\ 254 - 3\ 756$, you may ask yourself how much should be added to 3 756 to get 5 254:

$$3\ 756 + ? = 5\ 254$$

To make it easier to answer this question, you can start by filling up to 4 000:

$$3\ 756 + ? \rightarrow 4\ 000 + ? = 5\ 254$$

To make it even easier, you can use more steps:

$$3\ 756 + ? \rightarrow 3\ 800 + ? \rightarrow 4\ 000 + ? = 5\ 254$$

In fact, you can insert another step if you need one:

$$3\ 756 + ? \rightarrow 3\ 760 + ? \rightarrow 3\ 800 + ? \rightarrow 4\ 000 + ? = 5\ 254$$

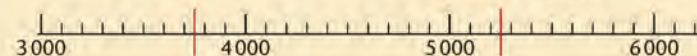

- Use any of the above ways to build up the answer for $5\ 254 - 3\ 756$.
- Work like in the above example to calculate each of the following:
(a) $7\ 178 - 3\ 535$ (b) $6\ 572 - 1\ 944$
(c) $9\ 062 - 5\ 368$ (d) $7\ 869 - 2\ 543$

Here is a different way to subtract 2 543 from 7 869:

$$7\ 869 \text{ is } 7\ 000 + 800 + 60 + 9 \text{ and}$$

$$2\ 543 \text{ is } 2\ 000 + 500 + 40 + 3.$$

To calculate $7\ 869 - 2\ 543$,

you can subtract 2 000 from 7 000,

500 from 800,

40 from 60,

3 from 9, and

then put the answers together to build up the answer for $7\ 869 - 2\ 543$.

- Use the above method to calculate the following:
(a) $8\ 856 - 3\ 243$ (b) $6\ 876 - 1\ 542$

Notes on questions

Question 4 is intended to prepare learners for the explanation in the tinted passage.

Teaching guidelines

Two closely related methods of subtraction are described in the two tinted passages – the underlying strategy in both methods is to **replace** the place value expansion of the bigger number with a different decomposition of the number.

Emphasise replacement as the underlying strategy when you do examples of both methods on the board.

Answers

4. (a) 543
(b) 544
5. (a) $6\,000 - 2\,000 = 4\,000$
 $900 - 800 = 100$
 $90 - 60 = 30$
 $9 - 6 = 3$
So, $6\,999 - 2\,866 = 4\,000 + 100 + 30 + 3 = 4\,133$
(b) Add 544; $7\,543 - 2\,866 = 4\,133 + 544 = 4\,677$
(c) $4\,677 + 2\,866 = 7\,543$
6. (a) 3 648
(b) 4 486
7. Yes, it is.
8. $13 - 6 = 7$
 $130 - 60 = 70$
 $1\,400 - 800 = 600$
 $6\,000 - 2\,000 = 4\,000$
So, $7\,543 - 2\,866 = 4\,000 + 600 + 70 + 7 = 4\,677$

4. What are the missing numbers in these number sentences?

- (a) $7\,000 + \dots = 7\,543$
(b) $6\,999 + \dots = 7\,543$

A difficulty arises when we try to calculate $7\,543 - 2\,866$ by breaking down both numbers into place value parts.

$7\,543$ is $7\,000 + 500 + 40 + 3$ and $2\,866$ is $2\,000 + 800 + 60 + 6$.

Now you will have to subtract 2 000 from 7 000,

800 from 500,

60 from 40 and

6 from 3.

Can you do this?

One way to deal with this difficulty is to keep in mind that

$$7\,543 = 544 + 6\,999,$$

and to then first subtract 2 866 from 6 999.

5. (a) Calculate $6\,999 - 2\,866$ by breaking down both numbers into place value parts.
(b) What do you have to add to your answer for $6\,999 - 2\,866$, to get the correct answer for $7\,543 - 2\,866$? Do that.
(c) Add 2 866 to your answer for (b) to check whether your answer for $7\,543 - 2\,866$ is correct.
6. Calculate the following in the way you have just calculated $7\,543 - 2\,866$.
(a) $6\,435 - 2\,787$ (b) $9\,362 - 4\,876$

Another way to calculate $7\,543 - 2\,866$ is to replace $7\,000 + 500 + 40 + 3$ with $6\,000 + 1\,400 + 130 + 13$.

7. Check whether $7\,000 + 500 + 40 + 3$ is equal to $6\,000 + 1\,400 + 130 + 13$.
8. Calculate $7\,543 - 2\,866$ by subtracting the place value parts of 2 866 from 13, 130, 1 400 and 6 000.

Mathematical notes

“Transfer” as mentioned in the tinted passage was traditionally referred to as “borrowing”.

Teaching guidelines

Note that learners are not required to perform any subtractions in question 9. The aim is to focus their attention on the step prior to actually subtracting (as they will do in question 10), namely the replacement.

Answers

9. (a) $8\ 000 + 400 + 30 + 2 \rightarrow 7\ 000 + 1\ 300 + 120 + 12$
(b) $9\ 000 + 10 + 4 \rightarrow 8\ 000 + 900 + 100 + 14$
(c) $7\ 000 + 500 + 60 + 6 \rightarrow 6\ 000 + 1\ 400 + 150 + 16$
(d) $8\ 000 + 100 + 40 + 1 \rightarrow 7\ 000 + 1\ 000 + 130 + 11$
10. (a) 2 534 (b) 3 116 (c) 1 668 (d) 2 243

3.6 Use brackets to describe your thinking

Teaching guidelines

Learners need to access the information recorded in this step of the calculation in the tinted passage, but may be challenged by what the brackets actually mean here:

$$(7\ 000 + 1\ 000) + (100 + 100) + (20 + 10) + 5$$
$$= 7\ 000 + (1\ 000 + 100) + (100 + 20) + (10 + 5)$$

The different placing of the brackets in the two lines is the conventional mathematical way of indicating two different orders in performing additions, which are possible because of the associative property of addition. In words:

“Instead of doing $(7\ 000 + 1\ 000) + (100 + 100) + (20 + 10) + 5$ by doing the calculations inside brackets first, one may do $7\ 000 + (1\ 000 + 100) + (100 + 20) + (10 + 5)$ by doing the calculations inside brackets first.”

Using horizontal curly brackets is a different way to represent the same rearrangement, and may help learners to understand more quickly:

$$= \underbrace{7\ 000 + 1\ 000} + \underbrace{100 + 100} + \underbrace{20 + 10} + 5$$

Use the example in the tinted passage to explain the rearrangement of the order of additions, and how this may be represented in two ways: with ordinary brackets and with horizontal curly brackets.

To change the expanded notation $8\ 000 + 200 + 30 + 5$ for the number $8\ 235$ to a form that will make it easier to subtract numbers from $8\ 235$, you can **transfer** parts of numbers as shown below:

$$8\ 235 = 8\ 000 + 200 + 30 + 5$$
$$= 7\ 000 + 1\ 100 + 120 + 15$$

9. Write each of these numbers in expanded notation. Then change the expanded notation to a form that will make it easy to subtract $5\ 898$ from the number.

To “transfer” means to move something; to take it from one place to another.

- (a) 8 432 (b) 9 014 (c) 7 566 (d) 8 141
10. How much is each of the following? You can use any method.
(a) $8\ 432 - 5\ 898$ (b) $9\ 014 - 5\ 898$
(c) $7\ 566 - 5\ 898$ (d) $8\ 141 - 5\ 898$

3.6 Use brackets to describe your thinking

When you want to calculate $8\ 235 - 4\ 789$ by breaking down both numbers into their place value parts, you will have to replace $8\ 000 + 200 + 30 + 5$ by something else to make it easy to subtract the parts from the parts.

Your thinking to do this can be shown in the following ways:

$$8\ 235 = 8\ 000 + 200 + 30 + 5$$
$$= 7\ 000 + 1\ 000 + 100 + 100 + 20 + 10 + 5$$
$$= 7\ 000 + 1\ 100 + 120 + 15$$

Another way to show how you are thinking is to use **brackets**:

$$8\ 235 = 8\ 000 + 200 + 30 + 5$$
$$= (7\ 000 + 1\ 000) + (100 + 100) + (20 + 10) + 5$$
$$= 7\ 000 + (1\ 000 + 100) + (100 + 20) + (10 + 5)$$
$$= 7\ 000 + 1\ 100 + 120 + 15$$

Mathematical notes

The associative property of addition provides the logical basis for replacing the place value expansion of a number with a different expansion. The associative property means that when you have to add a collection of numbers, you can group (associate) them in any way you like. Using brackets is one of a variety of ways to show a particular choice of what numbers are grouped together for the purposes of addition. Questions 1 and 2 are about subtraction; then the focus shifts to addition.

The replacement of $6\ 000 + 400 + 20 + 5$ with $5\ 000 + 1\ 300 + 110 + 15$ in question 2 involves the associative property only, but the replacement of $(5\ 000 + 200 + 30 + 5) + (3\ 000 + 300 + 50 + 2)$ with $(5\ 000 + 3\ 000) + (200 + 300) + (30 + 50) + (5 + 2)$ involves the associative as well as the commutative property of addition.

Answers

- $9\ 000 + 200 + 40 + 5$
 $= (8\ 000 + 1\ 000) + (100 + 100) + (30 + 10) + 5$
 $= 8\ 000 + (1\ 000 + 100) + (100 + 30) + (10 + 5)$
 $= 8\ 000 + 1\ 100 + 130 + 15$
- $6\ 425 = \overbrace{6\ 000} + \overbrace{400} + \overbrace{20} + 5$
 $= \overbrace{5\ 000 + 1\ 000} + \overbrace{300 + 100} + \overbrace{10 + 10} + 5$
 $= 5\ 000 + \overbrace{1\ 300} + \overbrace{110} + 15$

Teaching guidelines

With a view to get yourself informed about the state of your learners' grasp of addition, you may ask them to calculate $6\ 364 + 2\ 435$ and $6\ 364 + 2\ 877$ on a loose sheet of paper and take it in so that you can later analyse their work.

Then demonstrate how $5\ 235 + 3\ 352$ can be calculated by breaking each number down into place value parts, rearranging the parts, adding the similar parts and building up the answer, as described in the first tinted passage.

When learners have completed question 4, ask them to again calculate $6\ 364 + 2\ 435$ on a loose sheet of paper and hand it in. This will help you to assess the impact of your presentation and the practice learners experienced by doing questions 3 and 4.

Answers

- $5\ 235 + 3\ 352$
 $= (5\ 000 + 200 + 30 + 5) + (3\ 000 + 300 + 50 + 2)$
 $= (5\ 000 + 3\ 000) + (200 + 300) + (30 + 50) + (5 + 2)$
 $= 8\ 000 + 500 + 80 + 7$
 $= 8\ 587$
- (a) $9\ 416$ (b) $8\ 789$

- Use brackets to show how you would think to replace $9\ 000 + 200 + 40 + 5$ to make it easier to calculate $9\ 245 - 3\ 678$ by breaking down both numbers into place value parts.
- Use $\underbrace{\quad}$ signs instead of brackets to describe the thinking that is shown below.

$$\begin{aligned} 6\ 425 &= 6\ 000 + 400 + 20 + 5 \\ &= (5\ 000 + 1\ 000) + (300 + 100) + (10 + 10) + 5 \\ &= 5\ 000 + (1\ 000 + 300) + (100 + 10) + 15 \\ &= 5\ 000 + 1\ 300 + 110 + 15 \end{aligned}$$

To add numbers you can break them down into their place value parts. You can then rearrange and recombine the place value parts and build up the answer.

For example, to calculate $5\ 235 + 3\ 352$ you can think as follows:

$$\begin{aligned} & \quad 5\ 235 \quad + \quad 3\ 352 \\ &= \overbrace{5\ 000 + 200 + 30 + 5} + \overbrace{3\ 000 + 300 + 50 + 2} \\ &= \overbrace{5\ 000 + 3\ 000} + \overbrace{200 + 300} + \overbrace{30 + 50} + \overbrace{5 + 2} \\ &= 8\ 000 + 500 + 80 + 7 \\ &= 8\ 587 \end{aligned}$$

- Use brackets to show how $5\ 235 + 3\ 352$ was calculated in the above example.
- You can write in any way you prefer to do these calculations.
(a) $4\ 253 + 5\ 163$ (b) $6\ 134 + 2\ 655$

In some cases there is a slight problem.

For example, when you calculate $2\ 768 + 3\ 547$ in the way shown above, you end up with

$$\begin{aligned} & \quad 2\ 000 + 3\ 000 + 700 + 500 + 60 + 40 + 8 + 7 \\ &= 5\ 000 + 1\ 200 + 100 + 15 \end{aligned}$$

This must be replaced with the normal expanded notation before the answer can be built up:

$$\begin{aligned} & \quad 1\ 000 \quad 100 \quad 10 \\ & 5\ 000 + 1\ 200 + 100 + 15 = 6\ 000 + 300 + 10 + 5 = 6\ 315 \end{aligned}$$

Mathematical notes

A different format for addition and subtraction is introduced in Section 3.7 (page 40 of the Learner Book) as a first step towards adding and subtracting in columns (Term 3).

Answers

5. (a) $7\ 000 + 800 + 90 + 6$
(b) $4\ 000 + 200 + 30 + 1$
(c) $7\ 000 + 600 + 60 + 3$
6. (a) 8 275
(b) 7 346
(c) 7 783
(d) 6 552

Teaching guidelines

When learners have completed question 6, let them again calculate $6\ 364 + 2\ 877$ on a loose sheet of paper and hand it in, to allow you to assess whether the class has improved as a result of what happened in the classroom.

You may utilise the example in the first tinted passage to point out that the method they use for addition is only possible because numbers can be added in any order (the associative property of addition).

Answers

7. (a) 420
(b) 440
(c) 4 200
(d) 4 550
8. $6\ 154 - 2\ 769 = (155 + 5\ 999) - 2\ 769$
 $= 155 + (5\ 999 - 2\ 769)$
 $= 155 + 3\ 230$
 $= 3\ 385$

5. Write the following in the normal expanded notation.

- (a) $6\ 000 + 1\ 700 + 180 + 16$
(b) $3\ 000 + 1\ 100 + 120 + 11$
(c) $6\ 000 + 1\ 300 + 340 + 23$

6. Calculate each of the following by first breaking down both numbers into their place value parts.

- (a) $3\ 489 + 4\ 786$ (b) $2\ 784 + 4\ 562$
(c) $5\ 287 + 2\ 496$ (d) $3\ 987 + 2\ 565$

It is quite fortunate that numbers can be added in any order.

For example, to calculate $20 + 30 + 40$ it does not matter whether you do

$$(20 + 30) + 40 = 50 + 40 \text{ or}$$

$$(30 + 40) + 20 = 70 + 20 \text{ or}$$

$$(20 + 40) + 30 = 60 + 30.$$

The answer is 90 in all three cases.

7. Work out each total in the easiest way that you can.

- (a) $30 + 40 + 50 + 60 + 70 + 80 + 90$
(b) $20 + 30 + 40 + 50 + 60 + 70 + 80 + 90$
(c) $300 + 400 + 500 + 600 + 700 + 800 + 900$
(d) $350 + 450 + 550 + 650 + 750 + 850 + 950$

To calculate $7\ 234 - 3\ 576$

you can replace $7\ 000 + 200 + 30 + 4$ by $6\ 000 + 1\ 100 + 120 + 14$,

or

you can replace 7 234 by $235 + 6\ 999$.

You can use brackets to describe the second method:

$$7\ 234 - 3\ 576 = (235 + 6\ 999) - 3\ 576$$

$$= 235 + (6\ 999 - 3\ 576)$$

$$= 235 + 3\ 423$$

$$= 3\ 658$$

8. Calculate $6\ 154 - 2\ 769$ and show your thinking by using brackets. You can use any method to do the calculation.

3.7 Add and subtract 4-digit numbers

Teaching guidelines

Place value cards, included in the Addendum on pages 398 to 411 (which you may copy and laminate), can be used to act out the content of the tinted passage in the classroom. This will help learners to experience the breaking down of numbers into their place value parts and the rearrangement of the parts, which will not change the total because of the commutative and associative properties of addition.

Learners can work in pairs to form the numbers with their place value cards, and you can do the same by sticking your large place value cards on the board.

3487 2274

Ask learners to now take the numbers apart. Do the same on the board with another set of large cards so that the above remains on the board.

3000 400 80 7 2000 200 70 4

Ask learners to rearrange the cards so that the thousands cards are together, the hundreds cards are together, the tens cards are together and the units cards are together. Do the same on the board with another set of large cards.

3000 2000 400 200 80 70 7 4

Ask learners to add the numbers in each group and to represent the answer with cards in each case. Also do this on the board.

5000 600 100 50 10 1

The cards (parts) can be rearranged again. The answer 5 761 is now clear.

5000 600 100 5 10 1

Ask learners to write down what they did with the cards, using the tinted passage as a guideline if they wish.

Answers

- (a) 8 681 (b) 9 022 (c) 6 771 (d) 9 640 (e) 4 742 (f) 9 421
- (a) $8\ 681 - 6\ 297 = 2\ 384$ $8\ 681 - 2\ 384 = 6\ 297$
 (b) $9\ 022 - 7\ 834 = 1\ 188$ $9\ 022 - 1\ 188 = 7\ 834$
 (c) $6\ 771 - 3\ 902 = 2\ 869$ $6\ 771 - 2\ 869 = 3\ 902$
 (d) $9\ 640 - 6\ 771 = 2\ 869$ $9\ 640 - 2\ 869 = 6\ 771$
 (e) $4\ 742 - 1\ 795 = 2\ 947$ $4\ 742 - 2\ 947 = 1\ 795$
 (f) $9\ 421 - 5\ 432 = 3\ 989$ $9\ 421 - 3\ 989 = 5\ 432$

3.7 Add and subtract 4-digit numbers

Addition can be done by taking the following steps:

- Step 1:** Break both numbers down into their place value parts.
- Step 2:** Add each kind of place value part separately. This means add thousands to thousands, hundreds to hundreds, tens to tens and units to units.
- Step 3:** Make transfers if it is necessary.
- Step 4:** Combine the parts to build up the answer.

Example: Calculate $3\ 487 + 2\ 274$.

Step 1: $3\ 487 = 3\ 000 + 400 + 80 + 7$ and $2\ 274 = 2\ 000 + 200 + 70 + 4$

Step 2: $3\ 000 + 2\ 000 = 5\ 000$

$$400 + 200 = 600$$

$$80 + 70 = 150$$

$$7 + 4 = 11$$

Step 3: $3\ 487 + 2\ 274 = 5\ 000 + 600 + 150 + 11$

$$= 5\ 000 + 700 + 60 + 1$$

Step 4: $= 5\ 761$

Steps 2 and 3 can also be recorded as follows, to make it easier to keep track of the different place value parts:

$$3\ 487 = 3\ 000 + 400 + 80 + 7$$

$$2\ 274 = 2\ 000 + 200 + 70 + 4$$

$$3\ 487 + 2\ 274 = 5\ 000 + 600 + 150 + 11$$

- Calculate.

(a) $2\ 384 + 6\ 297$	(b) $7\ 834 + 1\ 188$
(c) $3\ 902 + 2\ 869$	(d) $6\ 771 + 2\ 869$
(e) $1\ 795 + 2\ 947$	(f) $5\ 432 + 3\ 989$
- Use your answers for question 1 to write two subtraction facts for each of the addition facts you have formed.

Teaching guidelines

Some learners are challenged by subtraction that involves “borrowing”.

In the explanation in the tinted passage, subtraction is not described as a stepwise process working “from right to left” through the different place value columns. Instead, with a view to make the mathematical nature of the process more transparent, subtraction is described as a series of steps enacted on the numbers in expanded notation.

Learners should preferably do a subtraction question that does not require “borrowing”, for example $7\ 854 - 2\ 532$, before engaging with the tinted passage. Demonstrate a simple case of subtraction on the board, for example $6\ 768 - 3\ 254$:

$$6\ 768 = 6\ 000 + 700 + 60 + 8$$

$$3\ 254 = 3\ 000 + 200 + 50 + 4$$

$$\begin{aligned} 6\ 768 - 3\ 254 &= 3\ 000 + 500 + 10 + 4 \\ &= 3\ 514 \end{aligned}$$

To confront learners with the challenge involved in more difficult cases, you may then write the task in the tinted passage on the board, leaving some space below the first line:

$$7\ 234 = 7\ 000 + 200 + 30 + 4$$

$$3\ 876 = 3\ 000 + 800 + 70 + 6$$

$$7\ 234 - 3\ 876 = ?$$

The problem in this case is that 6 cannot be subtracted from 4, the 70 cannot be subtracted from 30 and 800 cannot be subtracted from 200. Learners may be given some time to propose a solution to the problem, either of their own thinking or by consulting the tinted passage in their textbooks.

Answers

3. (a) 3 756 (b) 1 548 (c) 3 583 (d) 3 649

4. (a) 8 436

(b) Learners check and correct their answers to question 3(d).

5. (a) $7\ 632 - 3\ 876 = 633 + (6\ 999 - 3\ 876) = 633 + 3\ 123 = 3\ 756$

(b) Learners check their answers to questions 3(b) and (c) in the same way.

6. R4 367

7. R1 339

8. R3 777

Subtraction can be done by taking the following steps:

Step 1: Break down both numbers into their place value parts.

Step 2: Make changes to the place value parts of the first number if necessary.

Step 3: Subtract each kind of place value part separately. This means subtract thousands from thousands, hundreds from hundreds, tens from tens and units from units.

Step 4: Combine the parts to build up the answer.

Example: Calculate $7\ 234 - 3\ 876$.

$$\begin{aligned} \text{Step 1: } 7\ 234 &= 7\ 000 + 200 + 30 + 4 \\ &= 6\ 000 + 1\ 100 + 120 + 14 \quad (\text{Step 2}) \\ 3\ 876 &= 3\ 000 + 800 + 70 + 6 \end{aligned}$$

$$\begin{aligned} \text{Step 3: } 7\ 234 - 3\ 876 &= (6\ 000 - 3\ 000) + (1\ 100 - 800) + (120 - 70) + (14 - 6) \\ &= 3\ 000 + 300 + 50 + 8 \end{aligned}$$

$$\text{Step 4: } = 3\ 358$$

3. Calculate each of the following by using the above method.

(a) $7\ 632 - 3\ 876$

(b) $5\ 114 - 3\ 566$

(c) $6\ 457 - 2\ 874$

(d) $8\ 436 - 4\ 787$

4. (a) Calculate $4\ 787 + 3\ 649$.

(b) Is your answer for question 3(d) correct? If not, do it again.

5. (a) $7\ 632 - 3\ 876$ can also be calculated by replacing 7 632 by 633 + 6 999. Do this and check whether you get the same answer as when you did question 3(a).

(b) Check your answers for questions 3(b) and (c) in the same way.

6. Paul earned R8 245 and used R3 878 to buy a bicycle. How much money does he have left?

7. Mustafizur earns R5 225 per week and Cyril earns R3 886. How much more than Cyril does Mustafizur earn?

8. Carla has saved R5 678 to buy a leather couch that costs R9 455. How much more must she save before she can buy the couch?

3.8 Round off, estimate and solve problems

Teaching guidelines

Rounding off means that each of a group of different numbers is represented by the same number. For example, when rounding off to the nearest ten, each of the numbers 25, 26, 27, 28, 29, 30, 31, 32, 33 and 34 is represented by 30:

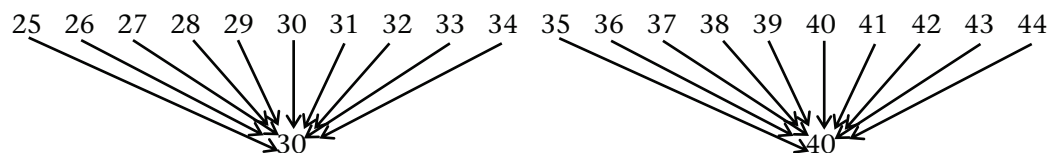

Similarly, when rounding off to the nearest hundred, each of the numbers 250, 251, 252, 253, 254, 255, 256, 257, 345, 346, 347, 348 and 349 is represented by 300:

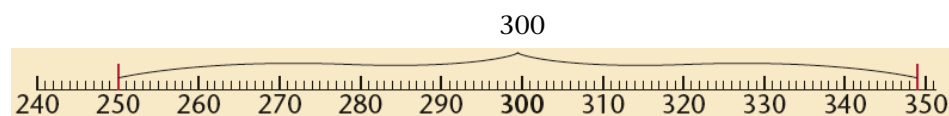

3.8 Round off, estimate and solve problems

It is sometimes useful to estimate approximate answers for addition and subtraction. A good way to do this is to round off the numbers, and to calculate using the rounded-off numbers.

For example, $7\,258 - 3\,574$ can be approximated by rounding off to the nearest thousand:

$$7\,000 - 4\,000 = 3\,000, \text{ so } 7\,258 - 3\,574 \text{ is approximately } 3\,000.$$

$7\,258 - 3\,574$ can also be approximated by rounding off to the nearest hundred:

$$7\,300 - 3\,600 = 3\,700, \text{ so } 7\,258 - 3\,574 \text{ is approximately } 3\,700.$$

The table below shows how rounding off to the nearest 100 is done. For example, all numbers between 150 and 249, including 150 and 249, are rounded off to 200.

Range	Rounded off to nearest 100	Examples
0 to 49	0	14, 34, 48, 49
50 to 149	100	50, 73, 101, 149
150 to 249	200	150, 188, 210, 249
250 to 349	300	250, 277, 325, 349
350 to 449	400	350, 359, 435, 449
.....
750 to 849	800	750, 786, 823, 849
850 to 949	900	850, 866, 899, 949
950 to 1 049	1 000	950, 967, 988, 1 049
1 050 to 1 149	1 100	1 050, 1 079, 1 149
.....
1 450 to 1 549	1 500	1 450, 1 485, 1 549

All the numbers between 250 and 349, including 250 and 349, are rounded off to 300.

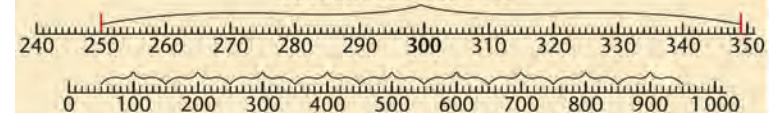

Answers

1. (a) 249
(b) 150
2. (a) 649
(b) 550
3. (a) Any five numbers between 350 and 449, including 350 and 449.
(b) Any five numbers between 1 150 and 1 249, including both 1 150 and 1 249.
4. (a) 1 649
(b) 1 550
5. (a) Any five numbers between 750 and 849, including both 750 and 849.
(b) Any five numbers between 2 250 and 2 349, including both 2 250 and 2 349.
(c) Any five numbers between 3 650 and 3 749, including both 3 650 and 3 749.
6. 500 500 600 1 100 3 200 3 300 8 700

Range	Rounded off to nearest 1 000	Examples
4 500 to 5 499	5 000	4 540, 5 340, 4 801, 5 489
5 500 to 6 499	6 000	5 600, 6 309, 6 010, 6 459
6 500 to 7 499	7 000	6 590, 6 880, 7 459, 7 009

8. 2 499 to nearest 1 000: 2 000
2 499 to nearest 100: 2 500

1. (a) What is the biggest number that is rounded off to 200?
(b) What is the smallest number that is rounded off to 200?
2. (a) What is the biggest number that is rounded off to 600?
(b) What is the smallest number that is rounded off to 600?
3. (a) Write five different numbers that are all rounded off to 400.
(b) Write five different numbers that are all rounded off to 1 200.
4. (a) What is the biggest number that is rounded off to 1 600?
(b) What is the smallest number that is rounded off to 1 600?
5. (a) Write five different numbers that are all rounded off to 800.
(b) Write five different numbers that are all rounded off to 2 300.
(c) Write five different numbers that are all rounded off to 3 700.
6. Round off each of the following numbers to the nearest 100:
513 548 550 1 111 3 249 3 250 8 749

Rounding off to the nearest 1 000 works in a similar way.

3 499 rounded off to the nearest 1 000 is 3 000 but
3 500 rounded off to the nearest 1 000 is 4 000.

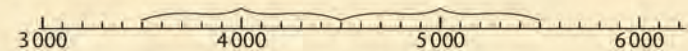

Range	Rounded off to nearest 1 000	Examples
0 to 499	0	140, 340, 480, 499
500 to 1 499	1 000	500, 730, 1 010, 1 499
1 500 to 2 499	2 000	1 500, 1 880, 2 499
2 500 to 3 499	3 000	2 500, 3 250, 3 499
3 500 to 4 499	4 000	3 500, 4 350, 4 499
.....

7. Continue the above table for numbers from 4 500 up to 7 499.
8. Round off 2 499 to the nearest 1 000, and to the nearest 100.

Teaching guidelines

Learners' efforts should be directed at understanding and solving the stated problem, not at trying to identify the correct operation as quickly as possible and applying a recipe to execute it.

Answers

9. Rounded off to the nearest...	10	100	1 000
2 317	2 320	2 300	2 000
2 344	2 340	2 300	2 000
2 345	2 350	2 300	2 000
2 349	2 350	2 300	2 000
2 499	2 500	2 500	2 000
8 005	8 010	8 000	8 000

10. (a) $2\ 000 + 5\ 000 = 7\ 000$
 (b) $2\ 400 + 4\ 500 = 6\ 900$
 (c) $2\ 370 + 4\ 520 = 6\ 890$
11. (a) $6\ 000 + 3\ 000 = 9\ 000$ (b) $9\ 000 - 4\ 000 = 5\ 000$
 (c) $9\ 000 - 5\ 000 = 4\ 000$ (d) $3\ 000 + 6\ 000 = 9\ 000$
12. (a) $6\ 500 + 3\ 200 = 9\ 700$ (b) $9\ 000 - 3\ 800 = 5\ 200$
 (c) $9\ 300 - 4\ 900 = 4\ 400$ (d) $3\ 500 + 5\ 600 = 9\ 100$
13. (a) 9 704 (b) 5 244 (c) 4 489 (d) 9 063
14. (a) 11(a) 704
 11(b) 244
 11(c) 489
 11(d) 63
 (b) 12(a) 4
 12(b) 44
 12(c) 89
 12(d) 37

9. Round off each of the following numbers to the nearest 10, the nearest 100, and the nearest 1 000.
 2 317 2 344 2 345 2 349 2 499 8 005
10. Estimate in three ways how much $2\ 366 + 4\ 522$ is:
 (a) by first rounding off each number to the nearest 1 000
 (b) by first rounding off each number to the nearest 100
 (c) by first rounding off each number to the nearest 10.
11. Estimate the answers to each of the following questions by rounding off the numbers to the nearest 1 000.
 (a) Lennie needs 6 468 bricks to build a small house and 3 236 bricks to build a wall around his plot. How many bricks does Lennie need in total?
 (b) The bricklayer has already used 3 786 bricks of the 9 030 bricks that were delivered at a building site. How many bricks are still left?
 (c) A school ordered 9 348 books from a supplier. When the school started in January, 4 859 books had been received. How many books are still outstanding?
 (d) There are 3 478 learners in School District A and 5 585 learners in School District B. How many learners are there in the two districts together?
12. Make new estimates for questions 11(a) to (d), this time by rounding off the numbers to the nearest 100.
13. Make accurate calculations to find the exact answers for questions 11(a) to (d).

The difference between an estimate and an accurate answer is called the **error**. For example, you can estimate that $3\ 747 + 4\ 874$ is 9 000. The accurate answer is 8 621. The error in this case is 379.

14. (a) Calculate the errors for your estimates in question 11.
 (b) Calculate the errors for your estimates in question 12.

Learner Book Overview		
Sections in this unit	Content	Pages in Learner Book
	Introducing numeric patterns	45
4.1 Patterns in the tables	Consolidating sequences of multiples	46 to 47
4.2 Equivalent flow diagrams	Developing properties of multiplication (order and grouping)	48 to 51
4.3 Sequences of non-multiples	Finding rules for families of sequences with a constant difference	51 to 53
4.4 Flow diagrams and rules	Consolidating completing flow diagrams	54

CAPS time allocation	4 hours
CAPS page references	18 to 19 and 136 to 139

Mathematical background

Numeric patterns, as part of the Content Area “Patterns, Functions and Algebra”, should serve as building blocks to develop the basic concepts of algebra in the Senior and FET phases. The study of numeric patterns should develop the idea of a relationship between two variable quantities, for example:

One variable quantity (the “input numbers”)	1	2	3	4	5	6	7	8	9	10	11
Another variable quantity (the “output numbers”)	4	7	10	13	16	19	22	25	28	31	34

The word “pattern” means that something is repeated. In the above case, the sequence 4, 7, 10, 13, 16, ... can be formed by repeatedly adding 3.

This pattern in the sequence can be formed by performing the same calculation each time to move from one number to the next.

Such a pattern is called a **recursive pattern**. The word “recur” means that something occurs repeatedly or repeats itself.

The above sequence of output numbers can also be formed by multiplying each input number by 3 and adding 1:

1	2	3	4	5	6	7	8	9	10	11
$3 \times 1 + 1$	$3 \times 2 + 1$	$3 \times 3 + 1$	$3 \times 4 + 1$	$3 \times 5 + 1$	$3 \times 6 + 1$	$3 \times 7 + 1$	$3 \times 8 + 1$	$3 \times 9 + 1$	$3 \times 10 + 1$	$3 \times 11 + 1$
4	7	10	13	16	19	22	25	28	31	34

A relationship between two variable quantities, in which each value of the second quantity is uniquely determined by the corresponding value of the first quantity, is called a **function** – the middle word in the CAPS title for this Content Area.

In the above case, the link between the input and output numbers (also called the independent and dependent variables) is given by the calculation plan (rule) “multiply the input number by 3 and add 1”, which can also be represented as $3 \times \square + 1$, or with this flow diagram:

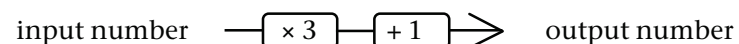

Overview of the approach to Numeric Patterns

The work on numeric patterns was designed along the following principles and guides:

Sequences of multiples

First, sequences of multiples (the “tables”) are thoroughly developed and reinforced with the intention that fluency with multiples will serve as a building block to study other sequences.

It is established that all the sequences of multiples are of the same type:

- The multiples of k have a constant difference of $+k$ between consecutive numbers (the “horizontal” pattern).
- The multiples of k have a rule of the form $\times k$ (the “vertical” pattern).

Families of sequences

Then it is established that sequences that are obviously different, can be the same in some respects. For example, the sequences in the series of sequences below are clearly different, but they are nevertheless the same in that they share the property that they have a constant difference of 4:

3, 7, 11, 15, 19, 23, 27, ...

4, 8, 12, 16, 20, 24, 28, ...

5, 9, 13, 17, 21, 25, 29, ...

6, 10, 14, 18, 22, 26, 30, ...

We call them “a family of sequences”.

By comparing the flow diagrams, tables and rules with a focus on the *relationship between these sequences*, a relationship between the calculation rules for these families of sequences can be identified, like this:

Sequence	Description in words	Flow diagram/ Rule
3, 7, 11, 15, 19, 23, 27, ...	One less than multiples of 4	$\boxed{-\times 4} \boxed{-1} \rightarrow$
4, 8, 12, 16, 20, 24, 28, ...	Multiples of 4 <i>Easy! Start here!</i>	$\boxed{-\times 4} \rightarrow$
6, 10, 14, 18, 22, 26, 30, ...	Two more than multiples of 4	$\boxed{-\times 4} \boxed{+2} \rightarrow$

UNIT
4
NUMERIC PATTERNS

What is mathematics?

Most mathematicians and scientists say,

“Mathematics is the study of patterns.”

The more patterns you can see in mathematics, the better you are at mathematics!

So, this year, we continue studying patterns ...

You will learn that in **number sequences** such as the one below, there is a **pattern** that does not change although the numbers change: there is a horizontal and a vertical **calculation plan (rule)** that is the same for all the input and output numbers:

Input numbers: 1 2 3 4 5 ...

$\downarrow \times 6$ $\downarrow \times 6$ $\downarrow \times 6$ $\downarrow \times 6$ $\downarrow \times 6$

Output numbers: 6 12 18 24 30 ...

$\curvearrowright +6$ $\curvearrowright +6$ $\curvearrowright +6$ $\curvearrowright +6$

We can describe the patterns in such sequences in **words**, in a **table**, in a **flow diagram** and in a **calculation plan**. These help us to solve problems such as the following:

1. Write down the next five numbers in the sequence 6, 12, 18, 24, ...
2. Calculate the 100th number in the sequence 6, 12, 18, 24, ...
3. Is 436 a number in the sequence 6, 12, 18, 24, ... or not? Explain!

GRADE 5: MATHEMATICS [TERM 1]
45

4.1 Patterns in the tables

Teaching guidelines

In starting our work on **sequences**, we connect it to the familiar work of counting in multiples and counting on in multiples.

You can therefore tell learners that it is not really new work; it is only different in the way it is represented. When counting, we usually do so *verbally*, but in our work with sequences we have to *write* it down.

Of course our focus is also different. Whereas our counting activities are mostly aimed at number concept development and mental fluency, our work with numeric patterns (number patterns) studies the relationships between the numbers in the sequences we produce.

And we ask different questions, for example:

If Sally would continue counting 5, 10, 15, 20, ...

- *what would the 100th number that she counted be?*
- *would she count 436?*

Our work on numeric patterns must develop the knowledge that will enable Sally to *calculate* the 100th number *instead of actually counting* all the way up to the 100th number, and to *reason* whether 436 is in the sequence or not, without actually having to count past 436.

Answers

1.

×	1	2	3	4	5	6	7	8	9	10
1	1	2	3	4	5	6	7	8	9	10
2	2	4	6	8	10	12	14	16	18	20
3	3	6	9	12	15	18	21	24	27	30
4	4	8	12	16	20	24	28	32	36	40
5	5	10	15	20	25	30	35	40	45	50
6	6	12	18	24	30	36	42	48	54	60
7	7	14	21	28	35	42	49	56	63	70

- Learners discuss methods used to complete the table, e.g. counting on in multiples.
- Learners discuss the patterns that they see in the table.

4.1 Patterns in the tables

Here is part of the multiplication table.

×	1	2	3	4	5	6	7	8	9	10
1	1	2	3	4	5	6	7	8	9	10
2	2	4	6	8	10	12	14	16	18	20
3	3	6	9	12	15					
4	4	8	12							
5	5	10	15				35			
6	6	12	18					48		
7	7	14	21							

- Complete the table.
- Which method(s) did you use to complete the table? Discuss.
- Discuss what patterns you see in the table, and how that helps you to “remember” the tables.

Sally completes the tables by using a **horizontal pattern**. The pattern is to add the same number every time, like this:

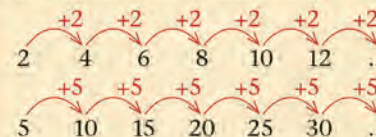

John completes the tables by using a **vertical pattern**. The pattern is to multiply by the same number every time, like this:



Teaching guidelines

You should let learners discuss what methods they are using, to help them realise that the different methods (horizontal differences and vertical rule) are useful for different purposes, so that they can make good decisions when deciding which method to use:

- To calculate the next five numbers, counting on in multiples is a good method.
- Counting on is not a good method to determine the 100th number. Rather use the multiplication rule.

Critical knowledge

The work in the next section (sequences of multiples) requires that learners fully understand the rule for sequences of multiples. It is therefore important that you consolidate this knowledge with learners.

Notes on questions

It is important that learners understand that flow diagrams and tables are equivalent representations. You should let learners discuss how the one is transformed into the other, and how they contain the same information.

Answers

4. (a) ..., 18, 20, 22, 24, 26 100th number: 200
 (b) ..., 24, 27, 30, 33, 36 100th number: 300
 (c) ..., 40, 45, 50, 55, 60 100th number: 500
 (d) ..., 56, 63, 70, 77, 84 100th number: 700
 (e) ..., 72, 81, 90, 99, 108 100th number: 900
 (f) ..., 80, 90, 100, 110, 120 100th number: 1 000

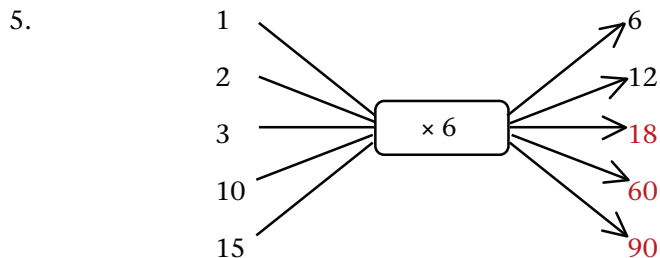

Position no.	1	2	3	10	15	20	40
$\times 6$	6	12	18	60	90	120	240

For every consecutive input number the output number increases by 6.
 The output number is always 6 times the input number.

4. Calculate the next five numbers and the 100th number in each table below. Are you going to use Sally's method, John's method, or a different method altogether?

- (a) 2, 4, 6, 8, 10, 12, 14, 16, ...
 (b) 3, 6, 9, 12, 15, 18, 21, ...
 (c) 5, 10, 15, 20, 25, 30, 35, ...
 (d) 7, 14, 21, 28, 35, 42, 49, ...
 (e) 9, 18, 27, 36, 45, 54, 63, ...
 (f) 10, 20, 30, 40, 50, 60, 70, ...

When the tables are written like this we call each row a **sequence**. We also call them **multiples**.
 3, 6, 9, ... is the sequence of **multiples of 3**.

We can also describe the sequences with a flow diagram or with a table.

5. Complete this flow diagram and table for multiples of 6.
 What patterns do you notice?

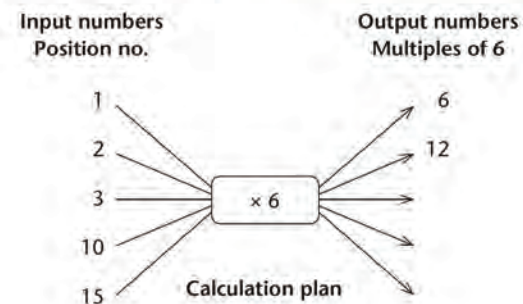

Position no.	1	2	3	10	15	20	40
$\times 6$	6	12					

4.2 Equivalent flow diagrams

Teaching guidelines

The main teaching and learning idea in this section is twofold:

- Establishing the *concept* of equivalence of flow diagrams (flow diagrams giving the same output numbers for the same input numbers) with the *implication* that one can therefore choose to use the one in the place of the other for specific purposes.
- Applying* the concept of equivalence to make calculation easier, especially to make mental calculation easier.

You should make sure that learners understand flow diagrams with two operators – see the note on the next page.

Answers

1. (a)

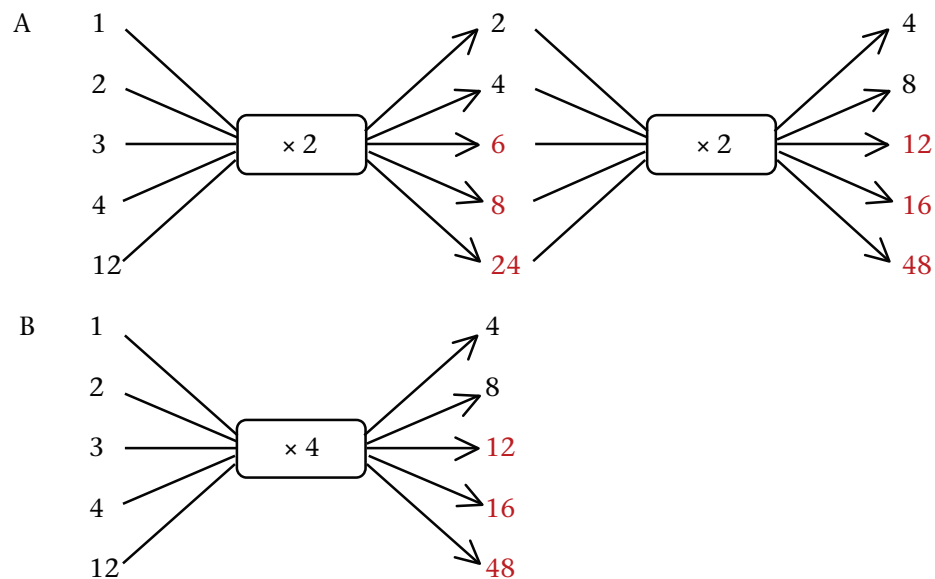

- (b) The flow diagrams are different in that they have different operators. They are the same in that the same input gives the same output. They are the same because multiplying by 2 and then by 2 again is the same as multiplying by 4.

4.2 Equivalent flow diagrams

- (a) Complete Flow diagrams A and B.
(b) Note that Flow diagram A has two parts of a calculation plan, and the output numbers of the first part are the input numbers for the second part.

Compare Flow Diagrams A and B. How are they different, and how are they the same?

Flow diagram A

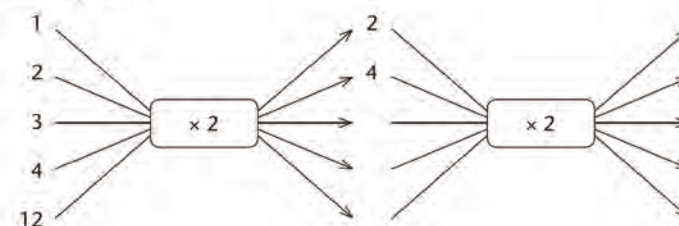

Flow diagram B

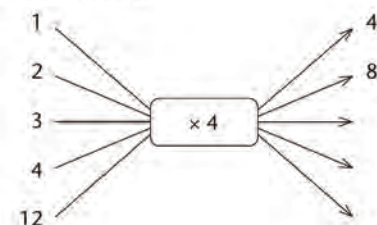

If two flow diagrams with different operators or order of operators give the same results, we say the flow diagrams are **equivalent**. Because they give the same results, we can choose which one we want to use.

So, because $4 = 2 \times 2$, instead of multiplying by 4, we can get the same answer by doubling, and then doubling the answer again.

Note on order of operations (BODMAS) and flow diagrams

You should make sure that learners understand flow diagrams with two operators.

The flow diagram representation carries an intuitive left-to-right procedure: the first input produces the first output; the second input produces the second output. For example:

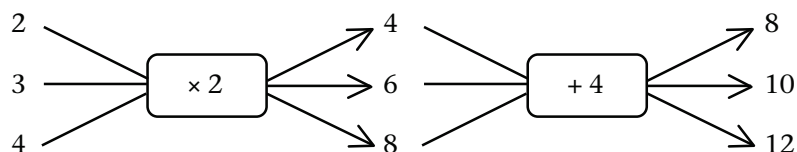

The left-to-right convention means that there is no need to learn rules such as BODMAS for the order of operations (first multiply before you add). BODMAS does *not* apply in the flow diagrams. For example, the following flow diagram is equivalent to the above.

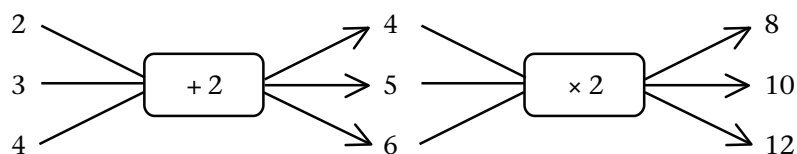

The flow diagram's left-to-right procedure plays the same role as brackets in numeric expressions. For example, to calculate the output value for the input 3, the first diagram uses the arithmetic expression $(3 \times 2) + 4$, and the second diagram uses $(3 + 2) \times 2$, and of course $(3 \times 2) + 4 = (3 + 2) \times 2$.

Answers

- 4×8 : double 8 is 16 and double 16 is 32, so $4 \times 8 = 32$
 - 4×9 : double 9 is 18 and double 18 is 36, so $4 \times 9 = 36$
 - 4×14 : double 14 is 28 and double 28 is 56, so $4 \times 14 = 56$
 - 4×11 : double 11 is 22 and double 22 is 44, so $4 \times 11 = 44$
 - 4×23 : double 23 is 46 and double 46 is 92, so $4 \times 23 = 92$
 - $8 \times 23 = 2 \times 4 \times 23 = 184$ (the previous answer, i.e. 92, doubled again)
 - $16 \times 14 = 14 \times 2 \times 2 \times 2 \times 2 \rightarrow 14, 28, 56, 112, 224$ (double 4 times), so $16 \times 14 = 224$
 - For C, D and E: $3 \rightarrow 18, 4 \rightarrow 24, 12 \rightarrow 72$
 - They have the same output values, so they are equivalent, because $2 \times 3 = 3 \times 2 = 6$.

- Madeleine says she does not have to learn the four times table, because she can very easily get the answer by doubling and doubling again. For example, for 4×7 she says: "7 doubled is 14 and 14 doubled is 28, so $4 \times 7 = 28$."

Use a plan like Madeleine's to easily calculate these:

$$4 \times 8 \quad 4 \times 9 \quad 4 \times 11 \quad 4 \times 14 \quad 4 \times 23 \quad 8 \times 23 \quad 16 \times 14$$

- Complete Flow diagrams C, D and E.
 - Now compare the flow diagrams. How are they different, and how are they the same?

Flow diagram C

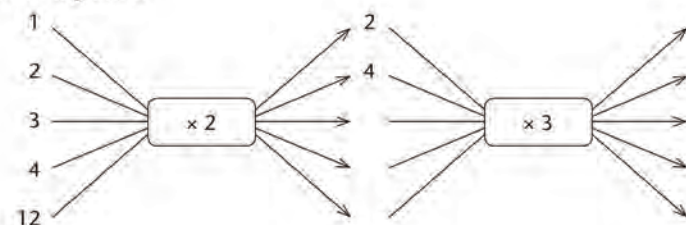

Flow diagram D

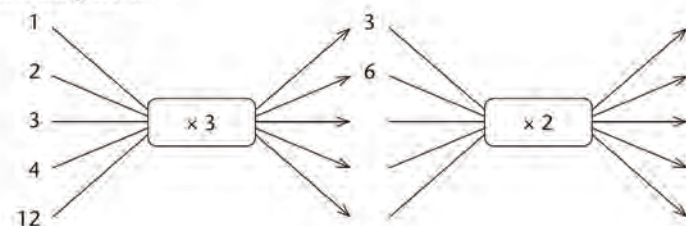

Flow diagram E

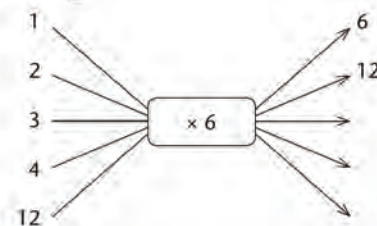

Teaching guidelines

In the answer for question 2(c) below, we use brackets to show which operations we are doing first, but you should not insist that learners use brackets.

Answers

2. (c) Various possibilities, for example:

$$9 \times 6 = (9 \times 3) \times 2 = 27 \times 2 = 54$$

$$9 \times 12 = (9 \times 6) \times 2 = 54 \times 2 = 108; 9 \times 3 \times 2 \times 2 = 27 \times 2 \times 2 = 54 \times 2 = 108$$

$$9 \times 24 = (9 \times 12) \times 2 = 108 \times 2 = 216; 9 \times 6 \times 4 = 54 \times 4 = 54 \times 2 \times 2 = 108 \times 2 = 216$$

$$8 \times 6 = (8 \times 3) \times 2 = 24 \times 2 = 48$$

$$11 \times 14 = (11 \times 7) \times 2 = 77 \times 2 = 154$$

$$32 \times 12 = (32 \times 3) \times 2 \times 2 = 96 \times 2 \times 2 = 192 \times 2 = 384$$

$$14 \times 20 = (14 \times 2) \times 10 = 28 \times 10 = 280$$

3. (a)

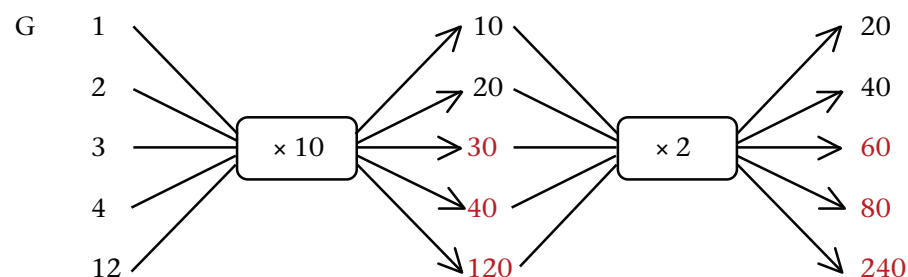
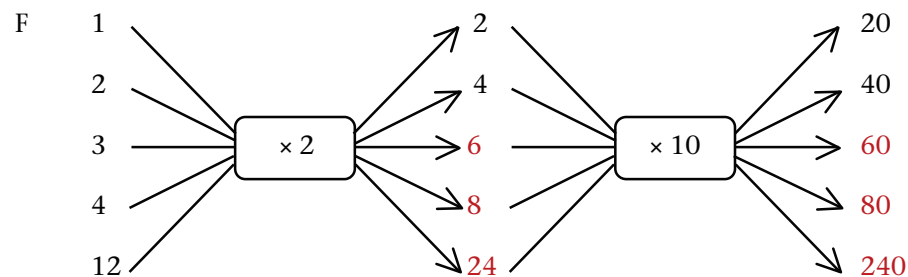

H $3 \times 20 = 60$ $4 \times 20 = 80$ $12 \times 20 = 240$

(b) The operators have been swapped in Flow diagrams F and G, but the output values are the same for the same input values, because the order does not matter. The output values of Flow diagram H are the same as for Flow diagrams F and G, but the operator is the product of the two operators, i.e. $\times 10 \times 2$ (or 2×10).

To multiply by 6, we can multiply by 2 and then multiply the answer by 3. Or we can first multiply by 3 and then by 2. The order does not matter.

(c) Try to split the numbers into smaller factors to make these calculations easier.

$$9 \times 6 \quad 9 \times 12 \quad 9 \times 24 \quad 8 \times 6 \quad 11 \times 14 \quad 32 \times 12 \quad 14 \times 20$$

3. (a) Complete Flow diagrams F, G and H.

(b) Compare the flow diagrams. How are they different, and how are they the same?

Flow diagram F

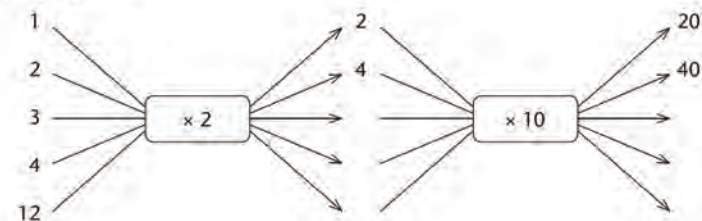

Flow diagram G

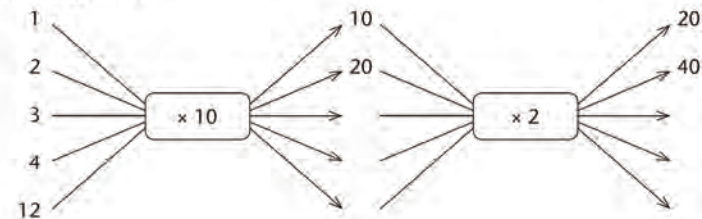

Answers

3. (c) Various possibilities, for example:

$$9 \times 20 = (9 \times 2) \times 10 = 18 \times 10 = 180$$

$$20 \times 12 = 10 \times (2 \times 12) = 10 \times 24 = 240$$

$$20 \times 20 = (2 \times 2) \times (10 \times 10) = 4 \times 100 = 400$$

$$8 \times 30 = 8 \times 3 \times 10 = 24 \times 10 = 240$$

$$8 \times 60 = 8 \times 6 \times 10 = 48 \times 10 = 480$$

$$9 \times 70 = 9 \times 7 \times 10 = 63 \times 10 = 630$$

$$9 \times 80 = 9 \times 8 \times 10 = 72 \times 10 = 720$$

4.3 Sequences of non-multiples

Teaching guidelines

We need to thoroughly reinforce sequences of multiples (“the times tables”) so that they will become easy for learners as a building block to study other sequences.

Have some **calculators** available for question 1.

Critical knowledge

All learners should understand, know and be able to apply the knowledge common to all multiple sequences: the multiples of k (1) have a constant difference of $+k$ and (2) have a rule of the form $\times k$, for example the rule for multiples of 3 is *Multiple no.* = $3 \times$ *Position no.*

Notes on questions

Problem solving is all about asking yourself the right questions, by *reformulating* a question from new information that you have. For A(c), the original question is: “Is 436 a number in the sequence?” After recognising A as multiples of 3, the question should be reformulated to: “Is 436 a multiple of 3?”, followed by “How do I find out if it is a multiple of 3?”

And then you answer your own question: “If 436 divided by 3 has no remainder.” Then you *do* it (let learners use the **calculator**): $436 \div 3 = 145.333\dots$ So 436 is not a multiple of 3. Therefore 436 is not in the sequence 3, 6, 9, 12, ...

Answers

1. A (a) ..., 21, 24, 27, 30, 33 (b) 300 (c) No

B (a) ..., 28, 32, 36, 40, 44 (b) 400 (c) Yes

C (a) ..., 42, 48, 54, 60, 66 (b) 600 (c) No

Flow diagram H

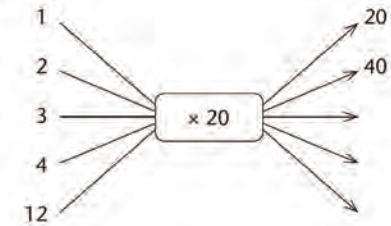

To multiply by 20, we can multiply by 2 and then multiply the answer by 10.
Or we can first multiply by 10 and then multiply the answer by 2.

(c) Try to split the numbers into smaller factors to make these calculations easier.

$$9 \times 20 \quad 20 \times 12 \quad 20 \times 20 \quad 8 \times 30 \quad 8 \times 60 \quad 9 \times 70 \quad 9 \times 80$$

4.3 Sequences of non-multiples

1. For each of the sequences of multiples below, do the following:

(a) Continue the sequence for the next five numbers.

(b) Find the 100th number in the sequence.

(c) Is 436 a number in the sequence? How do you know?

Sequence A: 3, 6, 9, 12, 15, 18, ...

Sequence B: 4, 8, 12, 16, 20, 24, ...

Sequence C: 6, 12, 18, 24, 30, 36, ...

You already know the above sequences of multiples (tables).

But what about sequences of non-multiples? Try question 2 now.

Teaching guidelines

Questions 2 to 4 are developmental activities, designed for learners to engage with the problem of finding rules for families of sequences with the same constant difference.

Question 5 is for consolidation. Learners should therefore complete and discuss all these activities.

The activities take learners through the problem (continuing the sequences and finding the 100th number) in different contexts, which all reinforce each other: flow diagrams, tables, rules.

It is important timewise, but especially conceptually, that learners do not have the mindset of answering each question as a stand-alone, isolated question. Rather, the vitally important idea here is that learners will see the *relationship between Sequences A, B, C and D* and therefore the relationship between the flow diagrams for the different sequences, and the relationships between the rules for the different sequences. For example:

$$\begin{array}{l}
 +1 \swarrow \quad 4, 8, 12, 16, 20, \dots \quad \text{Multiples of 4} \quad \text{Easy!} \quad 100\text{th number} = 100 \times 4 = 400 \\
 \quad \quad \quad \searrow \quad 5, 9, 14, 17, 21, \dots \quad \text{One more than multiples of 4} \quad 100\text{th number} = 100 \times 4 + 1 = 401 \quad \swarrow +1
 \end{array}$$

If learners can do this, they will have developed a very important and powerful problem-solving tool. It will make the work easy, and they can finish quickly.

Answers

2. (a) Same: the difference between the numbers is 4 in all four sequences.

Different: each sequence starts with a different number.

(b) A: ..., 32, 36, 40, 44, 48 100th number: 400

B: ..., 33, 37, 41, 45, 49 100th number: 401

C: ..., 34, 38, 42, 46, 50 100th number: 402

D: ..., 35, 39, 43, 47, 51 100th number: 403

(c) $436 \div 4 = 109$, so 436 is a multiple of 4. So, 436 is in Sequence A but not in B, C or D.

3. (a) A: ..., 100 $\xrightarrow{\times 4}$ $\xrightarrow{+0}$..., 400

B: ..., 100 $\xrightarrow{\times 4}$ $\xrightarrow{+1}$..., 401

C: ..., 100 $\xrightarrow{\times 4}$ $\xrightarrow{+2}$..., 402

D: ..., 100 $\xrightarrow{\times 4}$ $\xrightarrow{+3}$..., 403

Note: This alternative one-line flow diagram notation is for teachers, NOT for learners!

(b) They all have the same multiplication operator $\xrightarrow{\times 4}$ but different addition operators.

2. (a) What is the same and what is different in Sequences A to D?
 (b) Calculate the next five and the 100th number in each sequence.
 (c) For each sequence: Is 436 a number in the sequence or not?

Sequence A: 4, 8, 12, 16, 20, 24, 28, ...

Sequence B: 5, 9, 13, 17, 21, 25, 29, ...

Sequence C: 6, 10, 14, 18, 22, 26, 30, ...

Sequence D: 7, 11, 15, 19, 23, 27, 31, ...

Sequences A to D have *different* numbers, and they all start with different numbers. But they are all *the same* in the sense that all of them have the same horizontal pattern:

To get the next number you add 4.

So they are family!

If they are family, how are their flow diagrams and vertical patterns the same and how are they different?

3. (a) Fill in the calculation plan (rule) for each of the sequences in question 2 in these flow diagrams.
 (b) How are the flow diagrams (rules) different, and how are they the same?

Flow diagram A

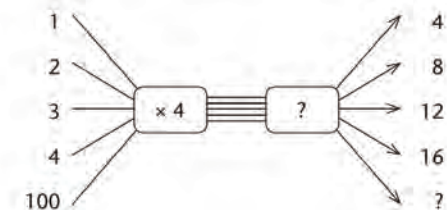

Flow diagram B

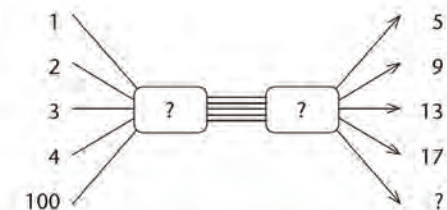

Mathematical notes

We emphasise again that for the required learning process and thinking strategy, learners need to concentrate on the *relationship between consecutive* sequences, flow diagrams and rules. Then, because the multiples are easy, the others follow, for example:

Position $\times 4 + 0$	4	8	12	16	20	24	120
	$\downarrow +1$	$\downarrow +1$	$\downarrow +1$				$\downarrow +1$
Position $\times 4 + 1$	5	9	13	17	21	25	121
	$\downarrow +1$	$\downarrow +1$	$\downarrow +1$				$\downarrow +1$
Position $\times 4 + 2$	6	10	14	18	22	26	122
	$\downarrow +1$	$\downarrow +1$	$\downarrow +1$				$\downarrow +1$
Position $\times 4 + 3$	7	11	15	19	23	27	123

Answers

3. C: ..., 100 $\xrightarrow{\times 4}$ $\xrightarrow{+2}$..., 402

D: ..., 100 $\xrightarrow{\times 4}$ $\xrightarrow{+3}$..., 403

4. (a)

Position	1	2	3	4	5	6	30
Position $\times 4$	4	8	12	16	20	24	120
Position $\times 4 + 1$	5	9	13	17	21	25	121
Position $\times 4 + 2$	6	10	14	18	22	26	122
Position $\times 4 + 3$	7	11	15	19	23	27	123

(b) All the sequences have a constant difference of 4 and the rules all have $\times 4$.

5. (a) All the sequences have a constant difference of 5, but different starting numbers.

(b) A: 500

B: 501

C: 502

D: 503

E: 504

(c) No

Flow diagram C

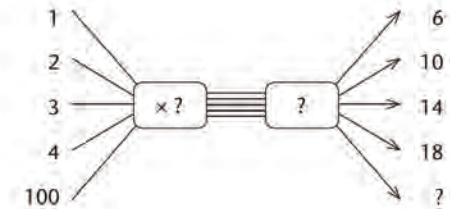

Flow diagram D

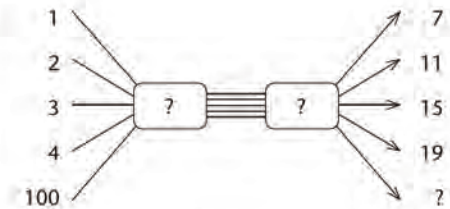

4. (a) Complete this table. Describe and discuss your methods.

Position	1	2	3	4	5	6	30
Position $\times 4$	4	8	12				
Position $\times 4 + 1$	5	9					
Position $\times 4 + 2$	6						
Position $\times 4 + 3$							

(b) What patterns do you see in the table? What is the same in each sequence, and what is the same in each calculation plan (rule)?

5. (a) What is the same and what is different in the sequences below?

(b) Calculate the 100th number in each sequence.

(c) For each sequence: Is 435 a number in the sequence or not?

Sequence A: 5, 10, 15, 20, 25, 30, 35, ...

Sequence B: 6, 11, 16, 21, 26, 31, 36, ...

Sequence C: 7, 12, 17, 22, 27, 32, 37, ...

Sequence D: 8, 13, 18, 23, 28, 33, 38, ...

Sequence E: 9, 14, 19, 24, 29, 34, 39, ...

4.4 Flow diagrams and rules

Teaching guidelines

For learners who have grasped the previous work on families of sequences and their flow diagram representations, this is a quick consolidation or reinforcement exercise, maybe leading to new insights. For learners who have not yet grasped the necessary concepts and notation, it offers another opportunity to do so.

Answers

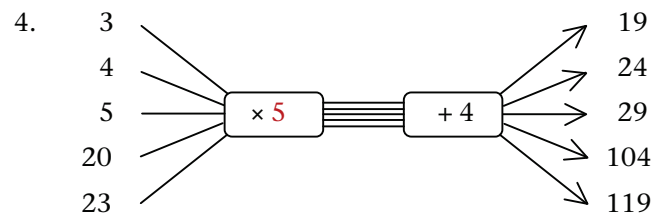
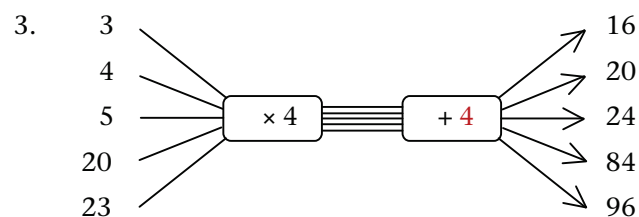
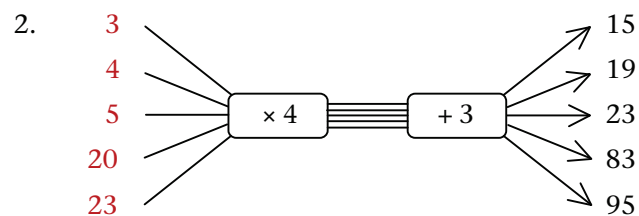
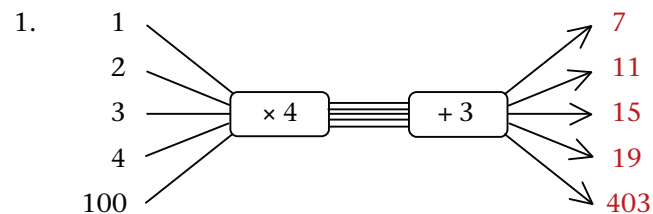

4.4 Flow diagrams and rules

Complete the missing parts in each of these flow diagrams.

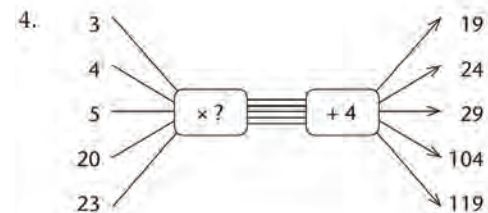
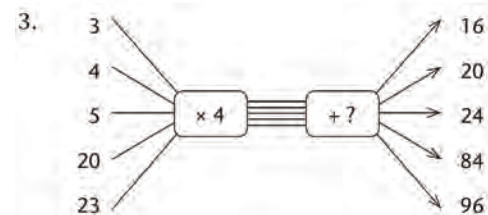
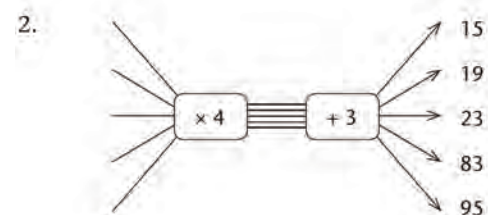
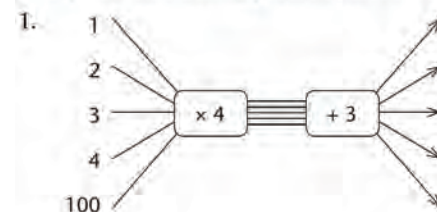

Learner Book Overview		
Sections in this unit	Content	Pages in Learner Book
5.1 What is multiplication?	The concept of multiplication	55 to 57
5.2 Multiplication facts	Mental Mathematics	58 to 59
5.3 Double, double and double again	Mental Mathematics	59 to 60
5.4 Multiply by building up from known parts	Breaking down and building up to multiply	61 to 62
5.5 Strengthen your knowledge of multiplication facts	Mental Mathematics	62 to 63
5.6 Practise multiplication and solve problems	Practice and problem solving	64 to 65
5.7 Multiples, factors and products	Terminology relating to multiplication	65 to 67
5.8 Division	Using the idea of division as the inverse of multiplication to solve grouping and sharing problems	67 to 68

CAPS time allocation	6 hours
CAPS page references	13 to 15 and 140 to 143

Mathematical background

The break down and build up method of multiplication comprises the following steps:

Step 1: Break down the numbers into place value parts, for example:

$$36 \times 47 = (30 + 6) \times (40 + 7)$$

Step 2: Distribute multiplication over addition:

$$(30 + 6) \times (40 + 7) = (30 + 6) \times 40 + (30 + 6) \times 7, \text{ and again:}$$

$$= 30 \times 40 + 6 \times 40 + 30 \times 7 + 6 \times 7$$

Step 3: Calculate the small products by using known facts:

$$= 1\,200 + 240 + 210 + 42$$

Step 4: Add up the parts:

$$= 1\,692$$

Division is normally performed by adding up multiples of the divisor. For example, the following combination of multiples can be used to calculate $578 \div 7$:

$$50 \times 7 = 350$$

$$20 \times 7 = 140, \text{ hence } 70 \times 7 = 350 + 140 = 490$$

$$10 \times 7 = 70, \text{ hence } 80 \times 7 = 490 + 70 = 560$$

$$2 \times 7 = 14, \text{ hence } 82 \times 7 = 560 + 14 = 574$$

So $578 \div 7 = 82$ and the remainder is 4.

5.1 What is multiplication?

Teaching guidelines

It is important that learners have some awareness of the wide variety of situations to which multiplication is applicable. Understanding multiplication narrowly, namely as repeated addition only, is a serious misconception that may withhold learners from noticing when the solution of problems requires multiplication for which repeated addition is not helpful.

By way of introduction, you may alert learners to some of the wide variety of real situations in which multiplication is applicable, including Situations A, B and C on page 55 of the Learner Book. Explain the difference between Situations A and C.

In Situation A it makes sense to think of a number of cans each costing R8.



In Situation C it makes *no sense* to think of a number of pictures of houses.



Rather, Situation C is about a **comparison** between the size of a picture and the size of an actual house:



To interpret Situation C, one may also think of “stretching” the picture in all directions so that it attains the size of the actual house.

Situation A is a **rate** situation – the cans of juice sell at a fixed rate (price in this case).

Situation C is a **ratio** or scale factor situation.

UNIT

5

WHOLE NUMBERS:

MULTIPLICATION AND DIVISION

5.1 What is multiplication?

We often know certain things about a situation, but then there may also be things that we do not know. Here are some examples.

- A. You may know that one can of juice costs R8 and that you need 23 cans. You may not know what the total cost of 23 cans is.



- B. You may know that there is 200 g of honey in a jar and that you will get only one eighth of it. You may not know how many grams of honey you will get.
 $\frac{1}{8}$ of 200 is $\frac{1}{4}$ of 100 which is . . .



- C. You may know that this house is 50 times bigger than the picture shows, and that the picture of the house is 4 cm high. You may want to know how high the actual house is.



What you do to find the information you need in situations like the above, is called **multiplication**.

Multiplication can be done in different ways, for example by repeated addition, by repeated doubling and by breaking down numbers into parts of which you already know the answers.

Teaching guidelines (continued)

Situation B (the jar of honey) on the previous page is related to Situation A, but it extends the meaning of multiplication into the domain of fractions.

A sequence of questions like these may help learners to understand that Situation B is similar to Situation A:

1. How many grams of honey are there in 3 jars of 200 g each?
2. How many grams of honey are there in $2\frac{1}{2}$ jars?
3. How many grams of honey are there in 2 jars?
4. How many grams of honey are there in $1\frac{1}{2}$ jars?
5. How many grams of honey are there in $1\frac{1}{4}$ jars?
6. How many grams of honey are there in $1\frac{1}{8}$ jars?
7. How many grams of honey are there in $1\frac{3}{8}$ jars?
8. How many grams of honey are there in $\frac{3}{4}$ of a jar?
9. How many grams of honey are there in $\frac{1}{8}$ of a jar?

Apart from enriching the meanings learners assign to multiplication, a sequence of questions like these may strengthen learners' concept of fractions.

Note that Situation B can also be understood as a situation that requires division: $200 \div 8$.

While it is important that learners know that multiplication can be performed as repeated addition, as shown for 23×8 in the tinted passage on page 56 of the Learner Book, it is important that they can do it in quicker ways, as shown. Learners should also realise that multiplication by doubling is only easy if you are skilled at doubling, and that multiplication by building up from known parts is only easy if you know basic multiplication facts. Emphasise this and tell learners that over the next two lessons, when they will be doing Sections 5.2 and 5.3, they will strengthen their knowledge of multiplication facts, their skills at forming multiplication facts and their skills at doubling.

Answers

1. $8 \times 23 = 8 \times 20 + 8 \times 3 = 160 + 24 = 184$
2. (a) $6 \times 32 = 6 \times 30 + 6 \times 2 = 180 + 12 = 192$
(b) Yes. $32 + 32 + 32 + 32 + 32 + 32 = 192$

Here and on the next page you can see four different ways to calculate the total cost of 23 cans of juice if each can costs R8.

By repeated addition

The total cost of 23 cans of juice at R8 each is

$$8 + 8.$$

To find the total you may add 8 repeatedly, 23 times:

$$8 + 8 \rightarrow 16 + 8 \rightarrow 24 + 8 \rightarrow 32 + 8 \rightarrow 40 \dots$$

Fortunately there are quicker and easier methods of multiplication.

By building up from known or easy parts

If you know some **multiplication facts**, for example that $10 \times 8 = 80$ and $3 \times 8 = 24$, you can work out 23×8 much more quickly.

$$8 + 8$$

$\underbrace{\hspace{10em}}_{10 \times 8} \quad \underbrace{\hspace{10em}}_{10 \times 8} \quad \underbrace{\hspace{3em}}_{3 \times 8}$

Clearly,

$$\begin{aligned} 23 \times 8 &= 10 \times 8 + 10 \times 8 + 3 \times 8 \\ &= 80 + 80 + 24 \\ &= 184 \end{aligned}$$

In this method, the 23 is actually broken down into 10 and 10 and 3, or into 20 and 3. That is why the method is sometimes called the **breaking down and building up method**.

1. Show how 23×8 can be calculated even more quickly if you know that $20 \times 8 = 160$.
2. (a) Suleiman buys 32 loaves of bread at R6 each. Work out how much this will cost in total. You can do it by adding 6 repeatedly, or by breaking the work down into easy parts.
(b) Can the total cost of the loaves of bread be calculated by adding 32 repeatedly? Try it.

Teaching guidelines

Demonstrate *doubling* and *rounding off and compensating* on the board with either the example 23×8 used in the tinted passages, or with another example (e.g. 42×17).

Answers

3. Yes. $28 + 28 = 56$, that is 2×28
 $56 + 56 = 112$, that is 4×28
 $112 + 112 = 224$, that is 8×28
4. $30 \times 8 = 240$, so $28 \times 8 = 240 - 2 \times 8 = 240 - 16 = 224$
5. (a) 32×29 by doubling:
 $32 + 32 = 64$, that is 2×32
 $64 + 64 = 128$, that is 4×32
 $128 + 128 = 256$, that is 8×32
 $256 + 256 = 512$, that is 16×32
 $29 = 16 + 8 + 4 + 1$
So, $32 \times 29 = 32 \times 16 + 32 \times 8 + 32 \times 4 + 32 \times 1$
 $= 512 + 256 + 128 + 32$
 $= 928$
- (b) 32×29 by rounding off and compensating:
Example: Round both numbers off to 30: $30 \times 30 = 900$
We still need 2×29 (double 29) = 58, but we took 1×30 too much.
 $32 \times 29 = 900 + 58 - 30 = 928$
(There are many other ways with rounding off and compensating. Consider learners' methods.)
- (c) 32×29 by breaking down into known or easy parts:
Example: $32 \times 29 = (30 + 2) \times (20 + 9)$
 $= (30 \times 20) + (30 \times 9) + (2 \times 20) + (2 \times 9)$
 $= 600 + 270 + 40 + 18$
 $= 928$

Multiplication by repeated doubling

$8 + 8 = 16$, that is 2×8
 $16 + 16 = 32$, that is 4×8
 $32 + 32 = 64$, that is 8×8
 $64 + 64 = 128$, that is 16×8

To "double a number" means to add it to itself. For example, to double 26 you may add it to itself:
 $26 + 26 = 52$

$23 = 16 + 4 + 2 + 1$ so
 $23 \times 8 = 16 \times 8 + 4 \times 8 + 2 \times 8 + 1 \times 8$
 $= 128 + 32 + 16 + 8$
 $= 184$

3. Do you think you can calculate 8×28 by doubling 28 repeatedly? Try it.

Multiplication by rounding off and compensating

To calculate 23×8 you may first round off the 23 to 20:
 $20 \times 8 = 160$

Of course this is not 23×8 .
We must change the 160 to undo the mistake we made by taking three eights too few.

So $23 \times 8 = 160 + 3 \times 8$
 $= 160 + 24$
 $= 184$

Changing an answer to undo a mistake is called **compensation**. In this case we compensate for the rounding off to 20 by adding 24 to 160.

4. Calculate 28×8 by rounding off and compensating.
5. Calculate 32×29 in three different ways:
- (a) by doubling
 - (b) by rounding off and compensating
 - (c) by breaking down into known or easy parts

5.2 Multiplication facts

Teaching guidelines

A good way to start this lesson is to put some 1-digit multiplication questions to the whole class, stating the questions verbally and also writing the questions and the answers (when given) on the board, for example:

How much is ...?

$$5 \times 6$$

$$5 \times 10$$

$$3 \times 7$$

$$6 \times 7$$

$$12 \times 7 \quad (\text{Suggest doubling if learners hesitate.})$$

$$6 \times 14$$

Draw learners' attention to the fact that the answers for 6×7 , 12×7 and 6×14 can all be obtained from $3 \times 7 = 21$, by doubling. Emphasise the idea that **if you know one fact you can form other facts from it**, for example by doubling.

Impress on learners that they need to know basic facts in order to be able to multiply with larger numbers.

Answers

- (a) 150, 175, 200, 225, 250, 275
(b) 90, 105, 120, 135, 150, 165
(c) 48, 56, 64, 72, 80, 88
(d) 54, 63, 72, 81, 90, 99
(e) 42, 49, 56, 63, 70, 77
- (a) 125 (b) 200 (c) 250 (d) 90
(e) 56 (f) 54 (g) 63 (h) 72
- (a) 18 (b) 120 (c) 21
(d) 42 (e) 420 (f) 28
- (a) 280 (b) 2 800 (c) 45
(d) 60 (e) 32 (f) 320

5.2 Multiplication facts

To be able to multiply bigger numbers by breaking them down into known parts, you need to know many multiplication facts. The work in this section will help you to form a greater knowledge of multiplication facts.

1. Write the next six numbers in each sequence:

(a) 25 50 75 100 125 ...

(b) 15 30 45 60 75 ...

(c) 8 16 24 32 40 ...

(d) 9 18 27 36 45 ...

(e) 7 14 21 28 35 ...

2. How much is each of the following?

(a) 5×25 (b) 8×25

(c) 10×25 (d) 6×15

(e) 7×8 (f) 6×9

(g) 7×9 (h) 8×9

When you multiply bigger numbers, for example 73×46 , you often have to do simple calculations like those above and below quickly. It will help you to practise. If you cannot do all the calculations below in the time that the teacher allows, you should complete these exercises in your own time.

Start by answering the questions for which you can give the correct answers *immediately*. You can think about the other questions later.

3. (a) 3×6 (b) 3×40

(c) 3×7 (d) 7×6

(e) 70×6 (f) 7×4

4. (a) 70×4 (b) 70×40

(c) 3×15 (d) 5×12

(e) 4×8 (f) 80×4

Answers

5. (a) 2 920 (b) 3 220
(c) 3 340 (d) 3 340
(e) 3 358 (f) 3 358
6. (a) 2 010 (b) 2 280
(c) 2 490 (d) 2 490
(e) 2 546 (f) 2 546
7. (a) 2 160 (b) 1 920
(c) 2 280 (d) 2 280
(e) 2 304 (f) 2 304
8. (a) 2 240 (b) 2 150
(c) 2 390 (d) 2 390
(e) 2 408 (f) 2 408

5.3 Double, double and double again

Mathematical notes

In order to use doubling effectively as a method of multiplication, it is important that learners learn to keep track of which multiples of the starting number are formed when the number is repeatedly doubled. For example, when 5 is repeatedly doubled, the following multiples of 5 are formed:

5	10	20	40	80	160	320
1×5	2×5	4×5	8×5	16×5	32×5	64×5

When 7 is doubled, the following multiples of 7 are formed:

7	14	28	56	112	224	448
1×7	2×7	4×7	8×7	16×7	32×7	64×7

You may do the above examples on the board to empower learners for questions 2 and 3 on the next page.

Answers

1. 400

5. (a) $2\,800 + 120$ (b) $2\,800 + 420$
(c) $2\,920 + 420$ (d) $3\,220 + 120$
(e) $3\,340 + 18$ (f) 73×46
6. (a) $1\,800 + 210$ (b) $1\,800 + 480$
(c) $2\,010 + 480$ (d) $2\,280 + 210$
(e) $2\,490 + 56$ (f) 38×67
7. (a) $1\,800 + 360$ (b) $1\,800 + 120$
(c) $2\,160 + 120$ (d) $1\,920 + 360$
(e) $2\,280 + 24$ (f) 96×24
8. (a) $2\,000 + 240$ (b) $2\,000 + 150$
(c) $2\,240 + 150$ (d) $2\,150 + 240$
(e) $2\,390 + 18$ (f) 43×56

5.3 Double, double and double again

You already know that to **double** a number means to add it to itself.

For example, when you double 5, you get 10.

When you double 10, you get 20.

When you double 20, you get 40.

When you double 50, you get 100.

When you double 100, you get 200.

1. What do you get when you double 200?

When you double 50 you get 100 which is $50 + 50$.

We can also say it is “two fifties” or 2×50 .

When you double again you get 200 which is $50 + 50$ and another $50 + 50$.

So when you double 50 and double again, you get 200 which is $50 + 50 + 50 + 50$.

We can also say this is “four fifties” or 4×50 .

By doubling, we have found the multiplication fact $4 \times 50 = 200$.

Teaching guidelines

Suggest to learners that they produce extended answers for questions 2 and 3, as demonstrated in the notes on the previous page for doubling 5 and 7 repeatedly.

Answers

2. (a) 8 fifties
(b) $8 \times 50 = 400$
3. (a) 240
(b) 2×30 ; 4×30 ; 8×30
(c) 480
(d) 2×60 ; 4×60 ; 8×60
4. (a) By adding 3 repeatedly 21 24 27
(b) By doubling repeatedly 48 96 192
(c) By adding 25 repeatedly 175 200 225
(d) By doubling repeatedly 400 800 1 600
(e) By doubling repeatedly 48 96 192
(f) By doubling repeatedly 72 144 288
(g) By adding 7 repeatedly 28 35 42
(h) By doubling repeatedly 56 112 224
(i) By doubling repeatedly 168 336 672
(j) By adding 6 repeatedly 24 30 36
5. (a) By repeated addition of 90
(b) 270
(c) 540
(d) 360
6. (a) By repeated doubling
(b) 560
(c) 280
(d) 1 120

2. (a) How many fifties do you get when you double 50, double again, and double once more?
(b) Which multiplication fact for 50 have you now found?
3. (a) Double 30, double again, and double once more.
(b) Which three multiplication facts for 30 have you found?
(c) Double once more.
(d) Which three multiplication facts for 60 have you found?
4. In each case, say whether the sequence was formed by doubling repeatedly or by adding repeatedly. Also write the next three numbers in each sequence.
- (a) 3 6 9 12 15 18 ...
(b) 3 6 12 24 ...
(c) 25 50 75 100 125 150 ...
(d) 25 50 100 200 ...
(e) 6 12 24 ...
(f) 9 18 36 ...
(g) 7 14 21 ...
(h) 7 14 28 ...
(i) 21 42 84 ...
(j) 6 12 18 ...
5. (a) How was this sequence formed?
90 180 270 360 450 540 630
(b) Which number in this sequence is equal to 90×3 ?
(c) Which number in this sequence is equal to 90×6 ?
(d) Which number in this sequence is equal to 4×90 ?
6. (a) How was this sequence formed?
70 140 280 560 1 120 2 240 4 480
(b) Which number in this sequence is equal to 70×8 ?
(c) Which number in this sequence is equal to 70×4 ?
(d) Which number in this sequence is equal to 16×70 ?

5.4 Multiply by building up from known parts

Teaching guidelines

The break down and build up method of multiplication is based on the distributive property of multiplication and addition. You can use the diagram in question 2(b) to discuss the distributive property at the start of this section. Ask learners to think of a quick way to find out how many blue rings there are in the diagram, and how many red rings.

Take feedback and conclude the discussion by stating that since there are 7 groups of 40 red rings each, the number of red rings is $7 \times 40 = 280$, and the number of blue rings is $7 \times 8 = 56$. Write these two results on the board. Then ask learners if it is true that the total number of rings in the picture is 7×48 . When this is agreed upon, ask learners whether the answer can be found by calculating $280 + 56$. Allow learners time to reflect on this, and discuss it in small groups.

Let learners then do questions 1 to 6, which will provide them with many opportunities to use the distributive property. The intimidating term “distributive property” need not and should preferably not be raised in class. Rather use an informal description such as “if you have to multiply two numbers by the same other number and find the total, you can first add the two numbers and then multiply”, with reference to a specific example like in question 2.

When learners have completed question 6, ask them to indicate which facts about smaller numbers they used to produce their answers.

Answers

- $4 \times 6 + 4 \times 9 = 4 \times (6 + 9)$, so $4 \times 15 = 24 + 36 = 60$
 - $4 \times 9 + 4 \times 15 = 4 \times (9 + 15)$, so $4 \times 24 = 36 + 60 = 96$
- 336
 - 336
- 288
- $6 \times 79 = 474$
 - $87 \times 4 = 348$
 - $363 \times 6 = 2\,178$
- 5×30 and 5×6 (b) 30×5 and 6×5
- $34 \times 50 = 1\,700$ (b) $34 \times 8 = 272$
 - $34 \times 50 + 34 \times 8 = 1\,972$ (d) $34 \times 58 = 1\,972$

5.4 Multiply by building up from known parts

- $4 \times 6 = 24$ and $4 \times 9 = 36$.
 - Combine the above two facts to find out how much 4×15 is.
 - Now you know how much 4×6 is, and 4×9 , and 4×15 . Note that $9 + 15 = 24$, and use what you know to find out how much 4×24 is.
- $7 \times 40 = 280$ and $7 \times 8 = 56$.
 - How much is $7 \times 40 + 7 \times 8$?
 - How much is 7×48 ?

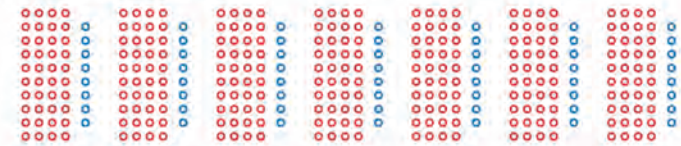

- Here are two multiplication facts: $8 \times 30 = 240$ and $8 \times 6 = 48$. How much is 8×36 ?
- Combine the given facts in each case to form another fact.
 - $6 \times 70 = 420$ and $6 \times 9 = 54$
 - $80 \times 4 = 320$ and $7 \times 4 = 28$
 - $300 \times 6 = 1\,800$, $60 \times 6 = 360$ and $3 \times 6 = 18$
- Which multiplication facts will make it easy to find out how much 5×36 is?
 - Which multiplication facts will make it easy to find out how much 36×5 is?

Here are some multiplication facts that you may use to find the answers for question 6:

$$30 \times 50 = 1\,500 \quad 4 \times 50 = 200 \quad 30 \times 8 = 240 \quad 4 \times 8 = 32$$

- How much is each of the following?
 - 34×50 (b) 34×8
 - $34 \times 50 + 34 \times 8$ (d) 34×58

Teaching guidelines

Questions 7 and 8 are intended to impress on learners that they need to have good knowledge of basic multiplication facts (“tables”) in order to be able to multiply fluently with larger numbers. Tell them that in Section 5.5 they will strengthen their knowledge of basic multiplication facts.

The second tinted passage is about alternative methods of multiplication. Do the example on the board and let learners then engage with question 9.

Answers

7. 50×40 and 3×40 and 50×7 and 3×7
8. (a) 50×60 and 7×60 and 50×8 and 7×8 $57 \times 68 = 3\ 876$
(b) 90×40 and 4×40 and 90×9 and 4×9 $94 \times 49 = 4\ 606$
(c) 60×60 and 8×60 and 60×8 and 8×8 $68 \times 68 = 4\ 624$
(d) 70×10 and 3×10 and 70×9 and 3×9 $73 \times 19 = 1\ 387$
(e) 80×80 and 7×80 and 80×8 and 7×8 $87 \times 88 = 7\ 656$
(f) 30×90 and 4×90 and 30×8 and 4×8 $34 \times 98 = 3\ 332$
(g) 50×50 and 7×50 and 50×2 and 7×2 $57 \times 52 = 2\ 964$
(h) 60×80 and 3×80 and 60×5 and 3×5 $63 \times 85 = 5\ 355$
9. $73 \times 19 = 73 \times 20$ (i.e. double 73 multiplied by 10) – 73 (i.e. one 73 less) = 1 387
 $34 \times 98 = 34 \times 100 - 2 \times 34$ (two 34s less) = 3 332
 $57 \times 100 = 5\ 700$, and half of that is 2 850
so, $57 \times 52 = 57 \times 50 + 57 \times 2$ (double 57)
= 2 850 + 114
= 2 964

5.5 Strengthen your knowledge of multiplication facts

Teaching guidelines

This section provides learners with opportunities to strengthen their knowledge of basic multiplication facts. Please see “Notes on questions” on the next page.

Answers

1. (a) 24 (b) 35 (c) 36 (d) 35 (e) 360
(f) 350 (g) 14 (h) 1 400 (i) 21 (j) 42
(k) 18 (l) 36 (m) 72 (n) 3 600 (o) 1 200
(p) 1 800 (q) 2 400 (r) 3 000

7. Which facts do you need to know to find out how much $53 \times 40 + 53 \times 7$ and 53×47 are?

To find out how much 46×73 is by using the breaking down and building up method, you need to know how much 46×70 is and how much 46×3 is. To know that, you need to know how much 40×70 , 6×70 , 40×3 and 6×3 are.

8. In each case state which facts you need to know so that you can easily find the answer by using the breaking down and building up method. If you know the facts that are needed, give the answer too.
- (a) 57×68 (b) 94×49 (c) 68×68 (d) 73×19
(e) 87×88 (f) 34×98 (g) 57×52 (h) 63×85

Note that 94×49 can be calculated as follows:

$94 \times 100 = 9\ 400$, and half of that is 4 700,
so $94 \times 50 = 4\ 700$.

94×49 is 94 less than 94×50 ,
so $94 \times 49 = 4\ 700 - 94 = 4\ 606$.

9. Show how 73×19 , 34×98 and 57×52 can be calculated in similar ways.

5.5 Strengthen your knowledge of multiplication facts

1. Write only the answers that you know in your book. If you do not know an answer, copy the question into your book, for example (d) $5 \times 7 =$. You will answer those questions later.

- | | | |
|--------------------|--------------------|--------------------|
| (a) 4×6 | (b) 7×5 | (c) 4×9 |
| (d) 5×7 | (e) 40×9 | (f) 5×70 |
| (g) 2×7 | (h) 20×70 | (i) 3×7 |
| (j) 6×7 | (k) 9×2 | (l) 4×9 |
| (m) 8×9 | (n) 40×90 | (o) 20×60 |
| (p) 30×60 | (q) 40×60 | (r) 50×60 |

Notes on questions

Questions 1, 3, 4(b), 5 and 6 provide learners with opportunities to assess their own knowledge of multiplication facts, and specifically to identify products for which they do not know the answers straightaway or cannot find the answers quickly. Questions 2 and 4(c) guide learners towards repeated counting as a way to establish multiplication facts that they do not know as yet.

Answers

2. (a) 30, 36, 42, 48, 54, 60

(b) 300, 360, 420, 480, 540, 600

(c) 3 000, 3 600, 4 200, 4 800, 5 400, 6 000

3. to 5. These questions can be done in table format under your guidance.

6. $70 \times 90 = 6\,300$ $60 \times 90 = 5\,400$ $70 \times 80 = 5\,600$ $60 \times 70 = 4\,200$

$80 \times 90 = 7\,200$ $40 \times 70 = 2\,800$ $80 \times 80 = 6\,400$ $90 \times 90 = 8\,100$

2. Write the next six numbers in each sequence. While you do this you may find the answers for some parts of question 1. Fill those answers in when you find them.

(a) 6 12 18 24 ...

(b) 60 120 180 240 ...

(c) 600 1 200 1 800 2 400 ...

3. Copy and complete this table of multiplication facts. In cases where you do not know the answer, you may look at the sequences that you wrote in question 2, or use any other method.

$3 \times 6 =$	$30 \times 6 =$	$3 \times 60 =$	$30 \times 60 =$
$7 \times 6 =$	$70 \times 6 =$	$7 \times 60 =$	$70 \times 60 =$
$8 \times 6 =$	$80 \times 6 =$	$8 \times 60 =$	$80 \times 60 =$
$5 \times 6 =$	$50 \times 6 =$	$5 \times 60 =$	$50 \times 60 =$
$2 \times 6 =$	$20 \times 6 =$	$2 \times 60 =$	$20 \times 60 =$
$9 \times 6 =$	$90 \times 6 =$	$9 \times 60 =$	$90 \times 60 =$
$6 \times 6 =$	$60 \times 6 =$	$6 \times 60 =$	$60 \times 60 =$
$4 \times 6 =$	$40 \times 6 =$	$4 \times 60 =$	$40 \times 60 =$
$10 \times 6 =$	$100 \times 6 =$	$10 \times 60 =$	$100 \times 60 =$

4. (a) Make a similar table for the multiplication facts for 7 and 70, but do not fill in any answers yet.

(b) Now fill in the answers that you know immediately.

(c) Try to find more answers. If you need to, you may also write sequences for 7, 70 and 700, like the sequences in question 2.

5. Do what you have done for 7 and 70 in question 4, for each of the following.

(a) 8 and 80

(b) 9 and 90

6. For which of the following can you give the answers straight away?

70×90

60×90

70×80

60×70

80×90

40×70

80×80

90×90

5.6 Practise multiplication and solve problems

Teaching guidelines

You may do some examples on the board at the start, for example:

$$\begin{aligned}56 \times 38 &= 50 \times 38 + 6 \times 38 \\ &= 50 \times 30 + 50 \times 8 + 6 \times 30 + 6 \times 8 \\ &= 1\,500 + 400 + 180 + 48 \\ &= 2\,128\end{aligned}$$

Emphasise the strategy to break the multiplication down into smaller parts for which the answers can be found easily.

Learners who do not read questions thoroughly will easily make mistakes in question 4. For example, some learners may simply add R22 and R34 and produce the false answer R56. Suggest to learners that for questions in which more than two numbers occur, they write a **calculation plan** before doing any calculations, and then reconsider the calculation critically by checking whether it corresponds to the given situation. A correct calculation plan for question 4 is $36 \times 22 + 48 \times 34$.

$12 \times 36 - 338$ is a correct calculation plan for question 5.

Both of $55 \times 43 - 346 - 129$ and $55 \times 43 - (346 + 129)$ are correct calculation plans for question 7.

Once learners have done question 5, you may use it to explain the concept “capacity”, which is important in the work on volume and capacity that learners will do later in the year. In the situation in question 5, the capacity of the train is $12 \times 36 = 432$ seated passengers.

Question 6 looks complicated, but there is a short way of doing it. The long route is to calculate the total cost of 43 ℓ in January ($43 \times R59 = R2\,537$), use this to calculate the total cost in February ($R2\,537 + R86 = R2\,623$), and use this to calculate the new selling price ($R2\,623 \div 43 = R61$). The short route is to argue that R86 more for 43 ℓ is R2 more for 1 ℓ, since $2 \times 43 = 86$.

Answers

- (a) 3 219 (b) 1 073 (c) 2 496 (d) 2 146
(e) 1 248 (f) 2 496 (g) 1 944 (h) 1 944
(i) 1 183 (j) 2 964 (k) 2 964 (l) 3 116
- (a) 2 496 trees (b) 1 248 trees
- (a) 1 944 apples (b) 1 656 apples
- R2 424 5. 94 empty seats
- R61 per litre 7. R1 890

5.6 Practise multiplication and solve problems

- How much is each of the following?
(a) 87×37 (b) 29×37
(c) 78×32 (d) 58×37
(e) 26×48 (f) 48×52
(g) 72×27 (h) 54×36
(i) 91×13 (j) 76×39
(k) 78×38 (l) 76×41
- (a) In a new plantation, 32 rows of 78 pine trees in each row were planted. How many trees were planted in this plantation?
(b) In another new plantation, 39 rows of trees were planted. Each row had 32 trees. What is the total number of trees planted in this plantation?
- For the export market, the apple packers have to wrap and pack the apples in boxes of 36.
(a) How many apples are packed in 54 boxes?
(b) How many more apples are needed to fill 100 boxes in total?
- Nandi is buying 36 cups and 48 bowls to serve coffee and soup at a netball tournament. The cups cost R22 each and the bowls cost R34 each. How much will Nandi pay in total for the cups and bowls?
- A passenger train has 12 carriages with 36 seats per carriage. How many empty seats are there if 338 people boarded the train?
- The Olive Farm Stall sold 43 ℓ of olive oil at R59 per litre in January. In February the farm stall owner put up the price and received R86 more for 43 ℓ. What was the new selling price for 1 ℓ of olive oil?
- Pam earns R55 for every hour that she babysits. Last month she looked after babies for 43 hours. She spent R346 on a pair of shoes and R129 on a dress. How much money does she have left over?

Teaching guidelines

Although learners may not recognise and do it as such, question 9(b) is a grouping situation. It can be calculated as $100 \div 26$, which has the answer 3 remainder 22. This means that with 3 rows only, 22 learners still need chairs. Hence the answer to the real question is 4 rows of chairs.

Question 10 involves ratio. Learners who quickly recognise the relationship between 18 and 72, i.e. that $72 = 18 \times 4$, may find the answer as follows:

If she sells 18 pancakes, she sells 42 muffins.

If she sells another 18 pancakes, she sells another 42 muffins.

If she sells another 18 pancakes, she sells another 42 muffins.

If she sells another 18 pancakes, she sells another 42 muffins.

*So if she sells $18 + 18 + 18 + 18 = 72$ pancakes,
she sells $42 + 42 + 42 + 42 = 168$ muffins.*

If learners do not make progress with question 10, you may ask them how many muffins they think Mrs Baker would sell if she sells 36 pancakes. This may put them on a path towards the solution.

Answers

8. (a) 1 494 cm (b) 6 cm
9. (a) 1 248 cm (b) 4 rows
10. 168 muffins

5.7 Multiples, factors and products

Teaching guidelines

Preferably use a different example than the one in the tinted passage to introduce the terms “factor”, “product” and “multiple”, for example $5 \times 9 = 45$.

The term “product” is used in two ways. The calculation plan 5×9 is called the product of 5 and 9, and the number 45 is also called the product of 5 and 9.

Answers

1. Any three, e.g. 2×18 ; 3×12 ; 4×9 ; 6×6
2. Example: 18, 30, 36, 54, 66 (*and many more; consider all answers*)

8. A wire artist has used up all his steel wire. He still needs 83 pieces of wire, each 18 cm long, to complete a wire sculpture.
 - (a) What is the total minimum length of wire that he needs?
 - (b) How many centimetres of wire will be left over if he can only buy wire in full metres?
9. Chairs are arranged in rows next to each other in the school hall for assembly. Each row has 26 chairs.
 - (a) How long is a row of chairs, if the width of each chair is 48 cm?
 - (b) How many rows of 26 chairs each are needed to seat 100 learners?
10. Last week, Mrs Baker sold 18 pancakes for every 42 muffins that she sold. If she sold 72 pancakes, how many muffins did she sell?

5.7 Multiples, factors and products

The number 48 can be obtained by calculating 6×8 .

We can say:

- 48 is the **product** of 6 and 8.
- 48 is a **multiple** of 6.
48 is also a multiple of 8.
- 8 is a **factor** of 48.
6 is also a factor of 48.

We can also **express** (write) 48 as the product of two whole numbers in other ways:

$$2 \times 24 = 48 \qquad 3 \times 16 = 48 \qquad 4 \times 12 = 48$$

And then we can also express 48 as the product of 1 and 48 because $1 \times 48 = 48$.

1. Write down three ways in which 36 can be expressed as a product of two numbers. The two factors may be equal.
2. 42 is a multiple of 6, because $6 \times 7 = 42$. 60 is also a multiple of 6, because $6 \times 10 = 60$. Write down five other multiples of 6.

Answers

3. (a) 1×24 2×12 3×8 4×6
(b) 1×36 2×18 3×6 4×9 6×6
(c) 1×60 2×30 3×20 4×15 5×12 6×10
(d) 1×72 2×36 3×24 4×18 6×12 8×9
(e) 1×100 2×50 4×25 5×20 10×10
(f) 1×120 2×60 3×40 4×30 5×24
 6×20 8×15 10×12
(g) 1×180 2×90 3×60 4×45 5×36
 6×30 9×20 10×18 12×15
(h) 1×240 2×120 3×80 4×60 5×48
 6×40 8×30 10×24 12×20 15×16
4. Examples: 80, 120, 160, 200, 240, 280, 320, 360, 400, 800, ...
5. (a) 7 (b) 12
6. (a) 40×10 (b) 40×11 (c) 40×12
(d) 40×13 (e) 40×16 (f) 40×18
7. (a) 30×20 (b) 30×23 (c) 30×24 (d) 30×28
8. (a) 468 (b) 472

Teaching guidelines

There is some danger that the focus on multiples and factors may lead learners to think that numbers can only be expressed as products, for example $472 = 8 \times 59$. Yet it is important that learners realise that numbers can also be expressed in the form product + remainder, for example $472 = 6 \times 78 + 4$. This is a formal way to express the answer for $472 \div 78$.

You may explain the content of the tinted passage without reference to division at this stage.

Answers

9. Learners' answers will vary. Consider all answers.
Example: $8 \times 109 = 872$ and $872 + 1 = 873$; so, $873 = 8 \times 109 + 1$
 $7 \times 124 = 868$ and $868 + 5 = 873$; so, $873 = 7 \times 124 + 5$

3. Find all the different ways in which each of the following numbers can be expressed as a product of two numbers.
(a) 24 (b) 36 (c) 60 (d) 72
(e) 100 (f) 120 (g) 180 (h) 240
4. Write down 10 multiples of 40.
5. (a) By what number do you have to multiply 40 to get 280?
(b) By what number do you have to multiply 40 to get 480?
6. Express each of the following numbers as a multiple of 40.
(a) 400 (b) 440
(c) 480 (d) 520
(e) 640 (f) 720
7. Express each of the following numbers as a multiple of 30.
(a) 600 (b) 690
(c) 720 (d) 840
8. How much is each of the following?
(a) 6×78 (b) $468 + 4$

Now think about what you worked out in question 8:

- In question (a) you worked out that $6 \times 78 = 468$.
- In question (b) you worked out that $468 + 4 = 472$.

So, the number 472 can be expressed as $6 \times 78 + 4$.

Note that the number added to the product is smaller than both factors of 468. (4 is smaller than 78 and it is also smaller than 6.)

Also note that one of the two factors of 468 is smaller than 10. (6 is smaller than 10.)

9. Now express 873 in the way 472 is expressed above.
The one factor must be smaller than 10, and the number added must be smaller than the smaller of the two factors.

Answers

10. (a) $8 \times 93 + 6$ (b) $8 \times 48 + 6$ (c) $8 \times 111 + 0$ (d) $8 \times 82 + 0$
11. (a) $6 \times 125 + 0$ (b) $6 \times 65 + 0$ (c) $6 \times 148 + 0$ (d) $6 \times 109 + 2$

5.8 Division

Teaching guidelines

It is important that learners distinguish between grouping and sharing in situations where a quantity is divided into equal parts. Use questions A and B as a vehicle to let learners experience the difference between grouping and sharing, i.e. between finding the number of equal parts and finding the size of the equal parts.

Put questions A and B in the tinted passage to learners, ask them to estimate the answers and to write the estimates down. Let them then check their estimates. You may have to demonstrate how they can check by multiplying in each case. There is no need to mention “division” at this stage: Learners should focus on the real Situations A and B to develop an understanding of the difference between sharing and grouping. Talking about division now may turn their minds away from the situations and make them think in terms of the given numbers only.

Let learners work for about 5 minutes, trying to find the accurate answers; then do questions A and B on the board. Use one side of the board for working on question A and the other side of the board for working on question B. In question A you have to find out how many pieces of 4 cm will make up 824 cm. You can build the number up in parts: 100 pieces of 4 cm each gives 400 cm of tape. Another 100 pieces brings you to 800 cm of tape. You can then add pieces one by one. (These actions are very similar to the steps in formal “long division”.) You may set the work out as follows:

Question A

100 pieces of 4 cm = 400 cm
100 pieces of 4 cm = 400 cm
5 pieces of 4 cm = 20 cm
1 piece of 4 cm = 4 cm
So, 206 pieces of 4 cm = 824 cm

Question B

If each piece is 100 cm, 8 pieces are 800 cm.
If each piece is 2 cm longer, the total is 816 cm.
If each piece is another 1 cm longer, the total is 824 cm.
So, each piece must be 103 cm long.

At this stage there is no need to set the work out more formally. The primary focus should be on learners thinking in terms of the real situations.

Answers

1. 42 classrooms 2. R60

10. Express each of the following numbers in the same way as above, using 8 as the smaller factor of the product part.

(a) 750 (b) 390 (c) 888 (d) 656

11. Now express each of the numbers in question 10 as a product of 6 and another number, plus a number smaller than 6.

5.8 Division

We use division to find information about situations like A and B below.

- A. How many ribbons, each 4 cm long, can be cut from a roll of 824 cm ribbon tape?
B. How long will each piece be if a roll of 824 cm ribbon tape is divided into 8 equal pieces?

In both situations, 824 cm of ribbon tape is divided into equal parts.

In Situation A, the **size of each part is known**, but the number of parts is not known.

In Situation B, it is the other way round: the number of equal parts is known, but the **size of the parts is not known**.

We use division for both these kinds of situations where a given quantity is made up of equal parts:

- A. to work out *how many parts there are*, if we know the size of the parts
B. to work out *how big each part is*, if we know the number of parts.

To do division, we may use our knowledge of multiplication facts.

For example, $824 \div 4$ can be worked out as follows:

$$200 \times 4 = 800 \text{ and } 6 \times 4 = 24.$$

$$\text{So, } 206 \times 4 = 824 \text{ and this means that } 824 \div 4 = 206.$$

Division is called the **inverse** of multiplication. “To invert” means “to go the opposite way”.

1. How many classrooms can get 6 new chairs each, if 252 new chairs are available?
2. What is the cost of one table if 7 tables cost R420?

Mathematical notes

Remainders have to be dealt with in different ways in different contexts.

In the situation described in question 3, the answer for $925 \div 4$ is 231 remainder 1. Yet the proper answer to the question is 231 pieces; the 1 cm left over (the remainder) is only a quarter of a 4 cm piece.

In the situation described in question 8(a), the answer for $194 \div 8$ is 24 remainder 2. However, this cannot be the answer to the question how many buses are needed. The number of buses needed is 25.

Notes on questions

Questions 3, 8(a) and (b), 9(a), (b) and (c) and 10 are grouping problems.

Questions 4 and 6(a) are sharing problems.

Question 7 is a two-step problem: the cost of one loaf must be calculated first (grouping).

Teaching guidelines

Questions 6 and 7 are similar. Question 7 is more demanding in the sense that learners have to decide by themselves to first calculate the cost of one loaf. Allow them the opportunity to struggle with question 7 and to devise the plan of first calculating the cost of one loaf themselves.

Answers

3. 231 pieces
4. 90 balls
5. (a) 141 (b) 113 (c) 113
(d) 86 (e) 125 (f) 81
6. (a) R9
(b) R342
7. R344
8. (a) 25 minibuses
(b) 59 minibuses
9. (a) 78 boxes (3 muffins left over)
(b) 52 boxes (3 muffins left over)
(c) 63 boxes
(d) R3
10. 14 days

3. How many pieces of 4 cm each can be cut from a roll of wire that is 925 cm long?
4. 720 netball balls are packed in 8 large crates. All the crates have the same number of balls. How many balls are there in each crate?
5. Calculate.
(a) $846 \div 6$ (b) $904 \div 8$ (c) $452 \div 4$
(d) $774 \div 9$ (e) $625 \div 5$ (f) $729 \div 9$
6. Fourteen cans of cooldrink costs R126.
(a) How much does one can cost?
(b) How much do 38 cans cost altogether?
7. Sixteen loaves of bread cost R128. How much do 43 loaves cost?
8. (a) How many minibuses are needed to transport 194 learners on an outing if each minibus can only seat 8 learners?
(b) How many minibuses are needed to transport 466 learners if each minibus can only seat 8 learners?
9. (a) Magda packs 315 muffins into boxes of 4 muffins each. How many boxes does she need?
(b) How many boxes will she need if she packs 6 muffins in each box?
(c) How many boxes will she need if she packs 5 muffins in each box?
(d) If Magda sells all 315 muffins for R945 in total, how much does she get for each muffin?
10. The Natural Sciences teacher has to mark 126 projects. If she marks 9 projects per day, how long will it take her to finish marking the projects?



Learner Book Overview		
Sections in this unit	Content	Pages in Learner Book
6.1 A little history	How people measured time before modern watches and clocks were invented	69
6.2 Daytime hours and night-time hours	Calculating time using 12-hour clocks	70
6.3 Read, tell and write time	24-hour time; digital and analogue clocks; hours, minutes and seconds	71 to 73
6.4 Intervals of time	Developing a sense of short time intervals; using language to describe time intervals; calculating time intervals in hours, minutes and seconds; reading stopwatches	74 to 78
6.5 Calendar time	Working with calendars; converting between days, weeks and months	78 to 79
6.6 Years and decades	Working with years and decades	80

CAPS time allocation	6 hours
CAPS page references	27 and 144

Mathematical background

Learners deal with time and time-related issues every day. Many Grade 5 learners can read clocks and watches, but just as many learners find them difficult to read. There are three issues that make the concept of time difficult:

- Firstly, time cannot be seen, touched or physically experienced like length, capacity/volume, area and mass. We measure time by looking at environmental changes or changes in the position of the hands of a clock or the numbers on a clock face.
- Secondly, unlike the number system and other forms of measurement, the numbers do not get bigger forever. We measure time in modular units: when we reach certain numbers (e.g. 60 seconds, 60 minutes, 24 hours, 365 days) the numbers wrap around and go back to the beginning. This is different to the way primary school learners work with numbers in other aspects of Mathematics.
- Thirdly, in all other topics in primary school Mathematics, numbers are organised in groups and powers of ten, but in the topic of time, numbers are organised in groups of 60, 24, 7, 12 and 365.

The topic of time involves more than just reading clocks. There are in fact three aspects of time that need to be developed:

- the duration of time
- the passing and sequencing of time
- identifying a point in time by, for example, reading a clock.

Note: Sections 6.1, 6.2, 6.5 and 6.6 are much shorter than the middle sections (6.3 and 6.4). You may want to consider combining Sections 6.1 and 6.2 into one lesson (i.e. aim to cover both in 1 hour). This will leave you more time for the two middle sections. Sections 6.5 and 6.6 can also be done together.

Resources

Analogue and digital clocks for demonstration purposes; stopwatches – see Section 6.4; calendars of the current year

6.1 A little history

Teaching guidelines

You can use the information on page 69 of the Learner Book as the basis for a discussion on how people told the time and kept track of time before there were clocks and watches.

You can start by asking learners how they can tell the time of year without a calendar and the time of day without a clock, watch (or cell phone). Learners would have made a water clock in Grade 4.

As suggested on the previous page, you might like to cover both Sections 6.1 and 6.2 in one lesson, i.e. in 1 hour.

UNIT

6

TIME

6.1 A little history

Very, very long ago, the ancient people were more concerned about “calendar time” than the time of day. To till their crops, knowledge of the seasons was important. It was only 5 000 to 6 000 years ago that the civilizations in the Middle East and Egypt found that they also needed ways to organise the time of day.



A sundial



An hourglass



A Greek water clock

In Egypt, at about 3 500 BC, the shadows of tall **obelisks** (tall pointed stone columns) moved like a kind of sundial dividing a day into “before noon” and “after noon”. These shadows also showed the shortest and the longest days of the year.

The Egyptians also developed the **sundial** around 1 500 BC to show the passing of hours. This device could of course only be used during daytime when the sun was shining.

Using a **water clock** was another way to measure time. The amount of water flowing out of or into a container at a steady pace was measured, and indicated the passing of time. Water clocks were used in Babylon (in modern-day Iraq) and Egypt around 1 600 BC. It is said that the Chinese used water clocks long before that.

Even today we sometimes use an old instrument in our kitchens to measure time, for example when we boil an egg. This instrument, filled with fine sand, is called an **hourglass**. Do you know how it works? Find out!

6.2 Daytime hours and night-time hours

Mathematical notes

In the Intermediate Phase, learners work with both 12-hour time (using a.m. and p.m.) and 24-hour time. This section focuses on 12-hour time; in the next section learners will work with 24-hour time.

Teaching guidelines

You might like to cover both Sections 6.1 and 6.2 in one lesson (see the note on the first page of this Teacher Guide unit).

Learners could answer questions 1, 3 and 5 in class, and do questions 2 and 4 for additional practice (e.g. as homework).

Possible misconceptions

Learners may not be sure how to write midday and midnight in 12-hour time. You may need to clarify for them that midday is called 12 p.m. and midnight is called 12 a.m. (see the table on page 72 of the Learner Book). This is simply a rule that has been adopted so that everyone uses the same notation (way of writing).

p.m. means after midday (from Latin “post meridiem”; “post” means after and “meridiem” means midday). a.m. means before midday (from Latin “ante meridiem”; “ante” means before).

Answers

1. 12 hours
2. 12 hours
3. 4:30 p.m.
4. 7:30 a.m.
5. 8 hours

6.2 Daytime hours and night-time hours

A **day** is the time it takes for the Earth to spin around on its own axis once. Half of the Earth faces the Sun. This half has light. The other half faces away from the Sun and so this half has darkness.

A day is divided into **24 hours**. We start counting the hours from midnight.

Even though we have 24 hours in one day most clocks show only 12 hours. The hour hand on this 12-hour clock moves around the clock twice in 24 hours.

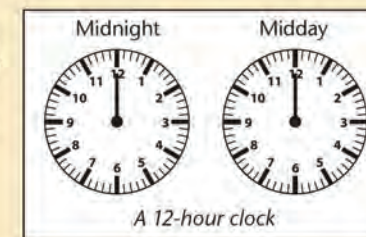

When your friend says he will phone at 7 o'clock, you need to know whether it is 7 o'clock in the morning or 7 o'clock in the evening. We write **7 a.m.** for the morning. We write **7 p.m.** for the evening.

1. Thembi travelled from Soweto to Port Elizabeth. She started her journey at 6 a.m. She arrived at 6 p.m. How many hours did she travel?
2. Mishack worked at the restaurant from midday to midnight. How many hours did he work?
3. Tim starts working at 8:30 a.m. He works for 8 hours. What time does he finish work?
4. Rose works for 8 hours each day. She finishes work at 3:30 p.m. What time does she start working?
5. Navi slept from 10 p.m. to 6 a.m. How many hours did she sleep?

6.3 Read, tell and write time

Teaching guidelines

You can check whether learners remember how many minutes there are in an hour, and whether they know how many seconds there are in a minute.

This section is quite long, so you might consider splitting the questions between classwork and homework (or work for additional practice in class whenever there is time). One option is to use

- question 1, the first two rows of question 3, and questions 4, 7, 8 and 9 as classwork, and
- question 2, the last two rows of question 3, and questions 5, 6, 10 and 11 as homework.

Possible misconceptions

Learners may find it difficult to understand why midnight is written as 00:00 in 24-hour time. You can show them what happens on the display of a digital clock, for example between 5 to 12 and 5 past 12. Also refer them to the tinted passage on pages 71 to 72.

Notes on questions

Learners could do question 2 in pairs or in small groups (maximum of three learners). Ask different pairs or groups to explain how they completed the table. Ways include: doubling and halving; addition or repeated addition; multiplication and division; counting in multiples of 15 ($\frac{1}{4}$ hour = 15 minutes) and 900 ($\frac{1}{4}$ hour = 900 seconds).

Answers

- (a) 1 hour = 60 minutes = 3 600 seconds (b) $\frac{1}{2}$ hour = 30 minutes = 1 800 seconds
(c) $\frac{1}{4}$ hour = 15 minutes = 900 seconds (d) $\frac{3}{4}$ hour = 45 minutes = 2 700 seconds

Hours	$\frac{1}{2}$	$\frac{3}{4}$	$1\frac{1}{2}$	2	$2\frac{1}{4}$	$2\frac{1}{2}$	3
Minutes	30	45	90	120	135	150	180
Seconds	1 800	2 700	5 400	7 200	8 100	9 000	10 800

Here is an example of how learners might explain their calculations:

For the first answer, we said that 1 hour is 60 minutes, so $\frac{1}{2}$ hour is 30 minutes. But an hour is also equal to 3 600 seconds, so $\frac{1}{2}$ an hour is 3 600 divided by 2, which is 1 800 seconds.

6.3 Read, tell and write time

About 4 000 years ago the Babylonians divided the **day** into 24 shorter parts of equal length, called **hours**. Each hour was then divided into 60 shorter parts of equal length, called **minutes**. Each minute was divided into 60 shorter parts called **seconds**.

How long is a minute?
Count steadily up to 60: "1 and 2 and 3 and 4 and 5 and 6... and 59 and 60."

We also talk about fractions of an hour, for example half an hour or a quarter of an hour.

- Complete the following:
 - 1 hour = ___ minutes = ___ seconds
 - Half an hour = ___ minutes = ___ seconds
 - One quarter of an hour = ___ minutes = ___ seconds
 - Three quarters of an hour = ___ minutes = ___ seconds
- Copy and complete the table. Explain your calculations.

Hours	$\frac{1}{2}$	$\frac{3}{4}$	$1\frac{1}{2}$	2	$2\frac{1}{4}$	$2\frac{1}{2}$	3
Minutes							
Seconds							

These two clocks show the same time: 30 minutes and 10 seconds past three in the morning.



The **analogue clock** on the left measures 12-hour time around a circle.

The **digital clock** on the right measures 24-hour time in numbers. Which clock do you find easier to read?

People catching aeroplanes may get confused between 8 a.m. and 8 p.m., so flight carriers use the 24-hour time notation. 8 p.m. is 20:00.

The hours from midnight through to the next midnight start at zero. In 24-hour time notation, one minute after midnight is written as 00:01.

Answers

3.

12-hour time	24-hour time	12-hour time	24-hour time
5 a.m.	05:00	2:00 p.m.	14:00
7:30 a.m.	07:30	3:12 p.m.	15:12
9:15 a.m.	09:15	5:32 p.m.	17:32
11:35 a.m.	11:35	11:45 p.m.	23:45
4. (a) D (b) C (c) A (d) B

Teaching guidelines

Do some language work with learners before you begin the next lesson. You can explain to them that the word “night” (which they know already) is used for all the hours between sunset and sunrise. But English also uses the word “evening” for the *first part* of the night – “evening” means the time between sundown and midnight.

English also uses the word “afternoon” for the last part of the day, between midday (noon) and sunset.

Note about resources and practical work

For Grade 5, the Curriculum and Assessment Policy Statement (CAPS)* states the following: “Learners continue to read, record and calculate time in 12-hour and 24-hour formats and to work with **analogue and digital instruments**. This is practised regularly. Once learners have been taught to tell the time, it can be practised during the **Mental Mathematics** section of the lesson, and frequently at other times during the day.”

*DBE (2011). *Curriculum and Assessment Policy Statement. Grades 4–6. Mathematics*. Government Printers, p. 144

	12-hour time	24-hour time
12 midnight	12 a.m.	00:00
5 minutes past midnight	12:05 a.m.	00:05
12 noon (midday)	12 p.m.	12:00
12 minutes past noon	12:12 p.m.	12:12
a quarter to 10 at night	9:45 p.m.	21:45

3. Complete the table.

12-hour time	24-hour time	12-hour time	24-hour time
5 a.m.			14:00
	07:30	3:12 p.m.	
9:15 a.m.			17:32
	11:35	11:45 p.m.	

4. Match the 12-hour clocks with the 24-hour clocks. Notice that a.m. or p.m. is written below the 12-hour clocks. Give your answer by writing the letter of the 24-hour clock next to the question number of the 12-hour clock, for example (a) E.

(a) 
p.m.

(b) 
a.m.

(c) 
p.m.

(d) 
p.m.

A	17:45:30
B	16:00:40
C	00:20:30
D	15:45:30

Notes on questions

To save classroom time, you can photocopy the clock faces provided in the Addendum on pages 417 and 418 for use with questions 6 and 8.

Answers

5. (a) 02:00 (b) 22:15 (c) 11:30 (d) 23:45
 (e) 04:00:30 (f) 21:00:15 (g) 19:39:50

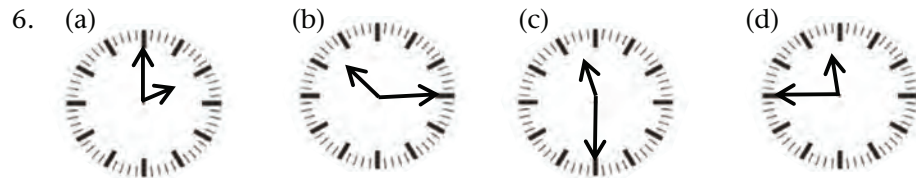

7. (a) 25 seconds past 9 in the morning
 (b) 15 minutes and 30 seconds past 8 in the morning
 (c) 5 seconds past 9 at night/in the evening
 (d) 15 minutes and 25 seconds past 12 in the afternoon
 (e) 50 minutes and 50 seconds past 11 at night or 9 minutes and 10 seconds before midnight
 (f) 12 minutes and 40 seconds past midnight
 (g) 54 minutes and 1 second past 7 in the evening or 5 minutes and 59 seconds before 8 at night/in the evening
 (h) 15 seconds past 3 in the afternoon

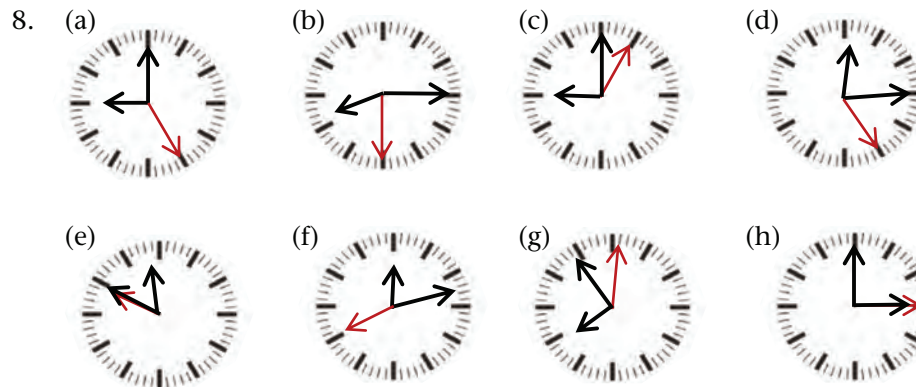

9. 2 hours 10 minutes 10. 06:45 11. 16:40

5. Write these times in 24-hour notation.
 (a) two o'clock in the morning
 (b) quarter past 10 at night
 (c) half past 11 in the morning
 (d) quarter to 12 at night
 (e) 30 seconds past 4 in the morning
 (f) 15 seconds past 9 in the evening
 (g) 20 minutes and 10 seconds to 8 in the evening
6. Draw analogue clocks that show the times in questions 5(a) to (d).
7. Write the times in words. For example:
 22:04:55 is 4 minutes and 55 seconds past 10 in the evening
 (a) 09:00:25 (b) 08:15:30
 (c) 21:00:05 (d) 12:15:25
 (e) 23:50:50 (f) 00:12:40
 (g) 19:54:01 (h) 15:00:15
8. Draw analogue clocks to show the times in question 7.
9. An aeroplane leaves from OR Tambo International Airport (Johannesburg) for Cape Town International Airport at 18:00. It lands at 20:10. How long was the flight?
10. A flight from King Shaka Airport (Durban) to OR Tambo International Airport took 45 minutes. The flight left at 06:00. At what time did the plane land?
11. A flight from Mthatha was scheduled to arrive at Cape Town International Airport at 16:00. It was 40 minutes late. At what time did the plane land?



6.4 Intervals of time

Teaching guidelines

Learners can either use stopwatches that occur as single instruments, or stopwatches on cell phones or wrist watches.

Digital stopwatches are usually easier to read than analogue stopwatches. Many cell phones have a stopwatch function, or the possibility of downloading a free stopwatch app. While learners are busy with classwork, you could work with small groups of learners to show them how a stopwatch works, and let them practise using it to measure intervals of time, for example timing the activities in questions 3(a), (b) and (c).

Answers

- I visited him *for a period of 20 minutes*.
 - during some other activity*: I shall walk *and* talk at the same time.
 - throughout* the time that school is taking place
 - starts = *begins*; ends = *stops* or *finishes*
 - lasted 4 hours = *came to an end after 4 hours*
 - Something happened between 10 o'clock and 11 o'clock: It could have been something quick, e.g. a tree fell down, or it could have been something that went on for an hour, for example a thunderstorm.
 - I *used up* an hour.
 - What is the period of time?*
- Answers will differ. Examples are:
long: How long will you be away?
between: The exam takes place between 09:00 and 12:00.
lasted: The party lasted 5 hours.
while: I ate my apple while I waited for the taxi.
during: We eat our sandwiches during break.
- Learners' estimates will differ.
- (c), (b), (a), (d), (e), (f)
- 5 days. There are 24 hours in a day. 5 days = 120 hours
- 87 months. There are 12 months in a year. 7 years = 84 months
- $2\frac{1}{2}$ minutes. There are 60 seconds in a minute. $2\frac{1}{2}$ minutes = 150 seconds

6.4 Intervals of time

- Discuss the meanings of the words printed in *italics*.
 - I visited him *for 20 minutes*.
 - I will speak to her *while* I walk home.
 - During school time* I don't use my cell phone.
 - The show *starts at eight* and *ends at eleven*.
 - The show *lasted 4 hours*.
 - It happened *between 10 and 11*.
 - It took me* an hour to walk to the train station.
 - How long* does it take a silkworm to spin a cocoon?
- Write your own sentences like those in question 1 using the following time words: long; between; lasted; while; during.
- Estimate the following lengths of time:
 - the time it takes a full kettle to boil
 - the time it takes to write "I am in Grade 5."
 - the time it takes to read "Last year, when I was in Grade 4, I was 9 years old."
 - the time it takes to walk the length of a soccer field
 - the time it takes for a shadow made by the sun to get 5 cm shorter
 - the time it takes a new candle to burn out
- Order your time estimates in question 3 from short to long lengths of time.
- Which is longer: 96 hours or 5 days? How do you know?
- Which is longer: 87 months or 7 years? How do you know?
- Which is shorter: $2\frac{1}{2}$ minutes or 160 seconds? How do you know?

An experiment

Use a candle that is at least 5 cm long. Measure and mark off the candle in 1 cm increments (parts), starting from the upper end of the candle. Estimate how long it will take the candle to burn down 1 cm, 2 cm and so on, and for it to burn out. Now light the candle and time it. How close were your estimates?

Answers

8. (a) Morning. It was before midday. The clock showed 08:35; in the evening it would have shown 20:35.
- (b) Twenty-five minutes to nine in the morning; 8:35 a.m.
- (c) 205 minutes
- (d) 15 minutes
- (e) Card 2: 16 minutes Card 3: 18 minutes
Card 4: 14 minutes Card 5: 17 minutes
- (f) It takes her between 14 to 18 minutes to make one card; the time varies by four minutes. Average time per card is about 16 minutes.
- (g) 80 minutes or 1 hour and 20 minutes
- (h) 125 minutes or 2 hours and 5 minutes
- (i) 10:20
- (j) Approximately 48 to 50 minutes. Yes, she will finish before her sister returns.

8. Annika is making eight greeting cards as a gift for her sister on her birthday. When she started, her digital watch showed 08:35. Annika wants to finish at 12 o'clock before her sister comes home from the netball game she is playing.
- (a) Is this in the morning or in the evening? How do you know?
- (b) Write the time she started in words and in 12-hour notation.
- (c) How many minutes does Annika have before her sister returns?
- (d) When Annika finishes the first card, the time is 08:50. How long did it take her to make the card?
- (e) Here you can see at what time the next four cards were finished. How long did she work on each card?
- Card 2: 09:06 Card 3: 09:24
Card 4: 09:38 Card 5: 09:55
- (f) What do you notice about the time she worked on each card?
- (g) How long did she work on the five cards?
- (h) How much time is left before her sister comes home?
- (i) After the fifth card Annika takes a 25 minute break. At what time does she start again?
- (j) Annika has to make three more cards. What do you think – how long will it take her? Why do you say that? (Look at your answer for question (f) again.) Will she finish before her sister returns?

We use a **stopwatch** to measure how long an activity takes. Look at this picture of an analogue stopwatch.

The numbers on the large dial (circle) indicate seconds and half seconds. The hand moves around once in 30 seconds (half a minute). While this hand turns, the minute hand on the smaller dial (circle) also turns.

When the second hand has completed two complete full turns, the minute hand on the smaller dial (circle) shows one minute. It takes 15 minutes for the minute hand to make a full turn in the small circle.



Answers

9. (a) 5 minutes 22 seconds
(b) 3 minutes 13 seconds
(c) 19 seconds
(d) 12 minutes $11\frac{1}{2}$ seconds

To start measuring how long an activity takes, you press the black button at the top. To stop measuring, when the activity is completed, you press the same button again. You press the button on the side to reset the stopwatch.

9. Four activities were timed with a stopwatch. How long did each activity take?



Answers

10. Learners' answers will vary.

These days we usually use digital stopwatches. Most cell phones have a digital stopwatch. A digital stopwatch is even more accurate than an analogue stopwatch. It accurately counts hundredths of a second, which are also called centiseconds.

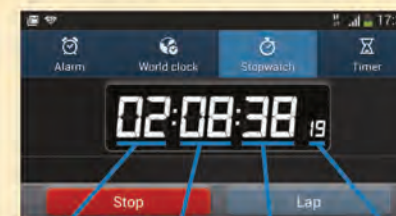

Counting in hours

Counting in minutes up to 59

Counting in seconds up to 59

Counting in centiseconds up to 99

10. You need to practise to use a stopwatch accurately.

- (a) Measure the lengths of time for activities such as those in question 3 as accurately as possible. (Note: some of the activities in question 3 may take too long to measure with a stopwatch.)
- (b) Compare your estimates to the measured time intervals. Work out how far your estimates were out.

11. In 2014, Bongumusa Mthembu from KwaZulu-Natal won the Comrades Marathon (about 90 km) in 5 hours 28 minutes and 34 seconds (05:28:34). Ludwick Mamabolo came second in a time of 5 hours 33 minutes and 14 seconds (05:33:14).

The times of the five fastest runners are recorded in the table below.

Runner	Country	Measured time	
1. Bongumusa Mthembu	KZN, SA	5h 28min 34s	05:28:34
2. Ludwick Mamabolo	Gauteng, SA	5h 33min 14s	05:33:14
3. Gift Kelehe	Limpopo, SA	5h 34min 39s	05:34:39
4. Stephen Muzhingi	Zimbabwe	5h 35min 18s	05:35:18
5. Rufus Photo	Limpopo, SA	5h 35min 30s	05:35:30

Answers

11. (a) 11:28:34
(b) 12 seconds
(c) 1 minute 25 seconds
(d) 4 minutes 40 seconds

6.5 Calendar time

Teaching guidelines

This section and Section 6.6 are much shorter than the middle sections (6.3 and 6.4). You might like to cover Sections 6.5 and 6.6 in 1 hour.

First assess how much learners know about how a year is put together – how many days there are in a year, in different months, and in a week, as well as how many months there are in a year. You can use the tinted passage on page 78 to fill in any gaps. You might need to check that learners know the difference between leap years and other years.

You could let learners complete question 1 in class and use question 2 for additional practice (e.g. as homework).

Answers

1. (a) to (d) Learners' answers will differ.
(e) Learners can count on their knuckles, starting with January on a knuckle, February off a knuckle, March on a knuckle, etc. All the months on knuckles have 31 days, as long as you count both July and August on knuckles. Learners can also recite rhymes such as:
*Thirty days has September,
April, June and November,
all the rest have thirty-one
except for February,
which has twenty-eight
– rain or shine –
but in leap years, twenty-nine.*
Accept any other correct ways that learners may suggest.
(f) Depends on the year.
(g) Depends on the year. No.

- (a) Mthembu started his race at 6 a.m. At what time did he cross the finishing line? Write the time in 24-hour notation.
(b) Muzhingi and Photo were very close. How much faster was Muzhingi than Photo?
(c) How much faster was Mamabolo than Kelehe?
(d) How much slower was Mamabolo than Mthembu?

6.5 Calendar time

Our **calendar year** is based on the time it takes the Earth to move once around the Sun, which is $365\frac{1}{4}$ days.

To make the calendar year a whole number of days, years do not all have the same number of days. Three **normal years** have 365 days each, and then every fourth year is called a **leap year** and has 366 days. The extra day is 29 February. 2012 was a leap year, so 2013, 2014 and 2015 were normal years.

The calendar year is divided into 12 periods called **months**. The months do not all have the same number of **days**: some months have 31 days, some months have 30 days, and February has 28 or 29 days.

A period of seven days is called a **week**, usually taken as starting on Sunday and ending on Saturday.

1. Find a calendar of this year.
(a) Mark today's date on the calendar.
(b) Mark your teacher's birthday on the calendar.
(c) Work out how long before or after your teacher's birthday it is today. Give the answer in months, weeks and days.
(d) How old are you today, in years, months, weeks and days? Show in writing how you calculated it.
(e) Some months have 31 days and other months have 30 days (except for February). Is there a pattern that you can use to tell quickly which months have 30 days?
(f) Which months have four full weeks? Which months have only three full weeks?
(g) On what day of the week was 1 January this year? Will it be on the same day of the week next year?

Answers

2. (a) 31 days
 (b) 4 full weeks
 (c) Yes. February has 29 days.
 (d) Thursday
 (e) 81 days
 (f) 56 days
 (g) 19 July; Tuesday (Note: 9 August is Women's Day, hence it is not a school day.)
 (h) Freedom Day; South Africa's first fully democratic election
 (i) 99 days
 (j) 18 August

2. The days marked in yellow on this 2016 calendar are public holidays.

JANUARY 2016							FEBRUARY 2016							MARCH 2016							APRIL 2016							
S	M	T	W	T	F	S	S	M	T	W	T	F	S	S	M	T	W	T	F	S	S	M	T	W	T	F	S	
				1	2		1	2	3	4	5	6			1	2	3	4	5							1	2	
3	4	5	6	7	8	9	7	8	9	10	11	12	13	6	7	8	9	10	11	12	3	4	5	6	7	8	9	
10	11	12	13	14	15	16	14	15	16	17	18	19	20	13	14	15	16	17	18	19	10	11	12	13	14	15	16	
17	18	19	20	21	22	23	21	22	23	24	25	26	27	20	21	22	23	24	25	26	17	18	19	20	21	22	23	
24	25	26	27	28	29	30	28	29						27	28	29	30	31		24	25	26	27	28	29	30		
31																												
MAY 2016							JUNE 2016							JULY 2016							AUGUST 2016							
S	M	T	W	T	F	S	S	M	T	W	T	F	S	S	M	T	W	T	F	S	S	M	T	W	T	F	S	
1	2	3	4	5	6	7			1	2	3	4							1	2	1	2	3	4	5	6		
8	9	10	11	12	13	14	5	6	7	8	9	10	11	3	4	5	6	7	8	9	7	8	9	10	11	12	13	
15	16	17	18	19	20	21	12	13	14	15	16	17	18	10	11	12	13	14	15	16	14	15	16	17	18	19	20	
22	23	24	25	26	27	28	19	20	21	22	23	24	25	17	18	19	20	21	22	23	21	22	23	24	25	26	27	
29	30	31					26	27	28	29	30			24	25	26	27	28	29	30	28	29	30	31				
														31														
SEPTEMBER 2016							OCTOBER 2016							NOVEMBER 2016							DECEMBER 2016							
S	M	T	W	T	F	S	S	M	T	W	T	F	S	S	M	T	W	T	F	S	S	M	T	W	T	F	S	
				1	2	3						1			1	2	3	4	5							1	2	3
4	5	6	7	8	9	10	2	3	4	5	6	7	8	6	7	8	9	10	11	12	4	5	6	7	8	9	10	
11	12	13	14	15	16	17	9	10	11	12	13	14	15	13	14	15	16	17	18	19	11	12	13	14	15	16	17	
18	19	20	21	22	23	24	16	17	18	19	20	21	22	20	21	22	23	24	25	26	18	19	20	21	22	23	24	
25	26	27	28	29	30		23	24	25	26	27	28	29	27	28	29	30			25	26	27	28	29	30	31		
							30	31																				

- (a) How many days are there in July?
 (b) How many full weeks does October have?
 (c) Is 2016 a leap year? Give a reason for your answer.
 (d) 16 June is Youth Day. On what day of the week does it fall in 2016?
 (e) The second school term starts on 5 April and ends on 24 June. How long is the school term? Give your answer in *days*.
 (f) How many *school days* does the second school term have?
 (g) The third term ends on 30 September. It has 53 *school days*. When does the third term start? And what day of the week is that?
 (h) What is 27 April called? Why is it a public holiday in South Africa?
 (i) Which is longer: 14 weeks or 99 days?
 (j) What is the date, three weeks from 28 July?

6.6 Years and decades

Teaching guidelines

Work through the tinted passage and the “timeline” with the class. You could also draw a timeline on the board, and ask learners to suggest events/information that you can add to it, for example:

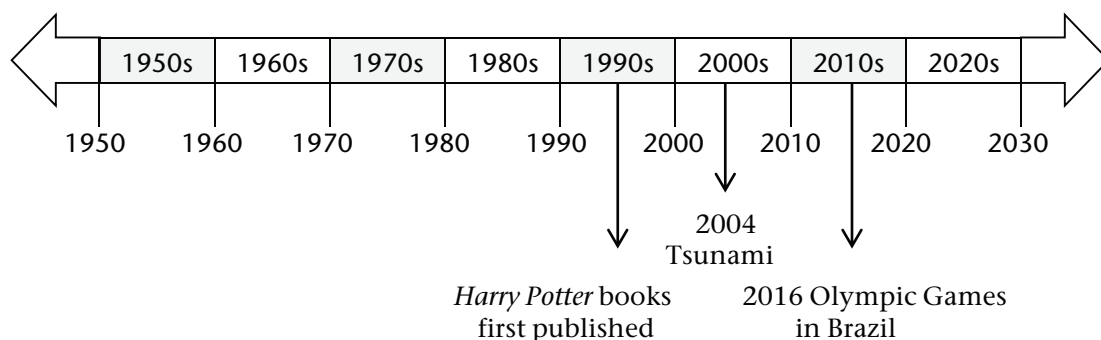

You could then also add the information that the learners bring to class – see question 5.

Answers

1. The answer depends on what today’s date is.
2. Learners’ answers are determined by their current age. They have to add 10 years to it.
3. Learners’ answers will differ, because it depends on how old they are now.
4. Learners’ answers will differ.
5. Learners’ answers will differ.

6.6 Years and decades

We talk about decades in two ways:

A **decade** is a period of 10 years.

We group the years in tens. We talk, for example, about the decade of the 1990s. The 1990s is the decade when South Africa became a true democracy.

We can also add ten years or subtract ten years from now. Then we say “in the next decade” and “in the previous decade” or “a decade ago”.

Here is a timeline of decades with some important events that took place, some of them from our own history.

1950s	1960s	1970s	1980s
Freedom Charter adopted	Sharpeville Massacre First man on the moon	Student protests Television in South Africa First cell phone	More protests FW de Klerk became President
1990s	2000s	2010s	2020s
South Africa's first democratic election Nelson Mandela became president	Cell phones became widely available	Soccer World Cup in SA Marikana Massacre	Still to come

1. What will the date be a decade from today?
2. How old will you be in a decade’s time?
3. How old were you a decade ago?
4. Who is the oldest person you know? In which decade was this person born?
5. Ask older people in your community what they remember from the decades in the timeline. Name more events or incidents that are not mentioned in the timeline.

Learner Book Overview		
Sections in this unit	Content	Pages in Learner Book
7.1 Asking questions about a situation	Asking questions that can be answered by collecting and analysing data	81 to 82
7.2 Drawing and interpreting graphs	Drawing and interpreting bar graphs, interpreting pie charts, and interpreting and drawing pictographs	83 to 86
7.3 Summarising and analysing data	Working with a data table, identifying the mode, drawing conclusions and making predictions	86 to 89
7.4 Project	Gathering data about waste at school	90

CAPS time allocation	10 hours
CAPS page references	30 to 31 and 145 to 146

In this unit we help learners to become familiar with the context of recycling from a data point of view. The unit provides opportunities to work on every step of the data-handling cycle, namely asking questions, gathering data, representing data, analysing and summarising data, and interpreting and reporting data about recycling. The topic lends itself to integration with Natural Sciences. If possible, you could get the latest information about waste recycling in South Africa and adapt the answers. This would enhance the relevance of the topic.

Mathematical background

Data are bits of information about a particular context. We ask questions about a situation or context that lead to the collection of information. The way in which the data are organised and represented, and the further questions that we ask, allow us to see trends in the data. In data handling we usually work with large amounts of information related to particular contexts. Instead of focusing on each bit of information separately, the way we organise, represent and analyse the data gives us ways of talking in general about the data. We look at the data in a global way and draw out trends or characteristics that describe the data.

Data handling differs from other parts of Mathematics in three respects:

- **The answer to data questions is in the information from lots of data gathered.**

Data handling is necessary where measurements and frequencies vary, and therefore one measurement cannot provide accurate information about a situation. Lots of different data can be confusing, so we organise the data that we collect in different ways to get a “picture” of the situation.

- **The numbers we use in data handling always have some description of a category they belong to, or some unit of measurement.**

In Mathematics, learners work mostly with abstract numbers. In data handling the numbers must be interpreted in a context. The same number 245 can be 245 kg or 245 people, depending on the question.

- **Data questions are always answered with a story about the context.**

Data handling starts when we need to answer a question about a situation where the property we look at varies. The numerical answers we get by data handling must be interpreted to answer the question about the situation.

7.1 Asking questions about a situation

Teaching guidelines

You may introduce the work in this unit by explaining the meaning of the word “data”: Say we want to answer questions such as “How many learners in our school don’t like to read storybooks?”, “Why don’t they like to read storybooks?”, “If they were told by their teacher to read at least one storybook this term, what type of storybook would they choose?”, etc. The facts, information or opinions that we collect and use as a basis to analyse and discuss a problem or to suggest answers or solutions, are called data.

Discuss the benefits of recycling with learners, especially from an environmental point of view. Also discuss possible recyclable material in the school environment.

Some of the questions in this section are designed to help learners clarify their own thoughts and questions about recycling. Writing down their own questions about recycling can help to stimulate learners’ interest in the topic. Their questions will also help you to better understand learners’ prior knowledge about recycling.

You might like to ask learners to discuss the answers to questions 1 and 2 in pairs but to record their work individually. It is important that you let learners share their answers and have class discussions so that everyone can learn from each other. You might like to let learners share their answers to questions 1 and 2 before working through question 3 on page 82. The ideas generated here will help with the project in the final section.

Answers

- Here are some possible questions: I wonder how much glass (or paper or plastic) is recycled every month in the town where I live? I wonder how much recyclable waste ends up in our town’s landfill(s)? I wonder how much waste we can recycle at home and what kinds of waste? I wonder how much glass (or paper or plastic) a waste collector collects every day? I wonder how many people sort their waste? I wonder why some people recycle and others don’t? I wonder how much we can earn by recycling glass (or paper or plastic)? I wonder what is the most popular material to collect for recycling?
- Waste is anything that someone does not need anymore. Things *become* waste when they are not needed any more, for example when we have used the milk in a container or food in a tin, the container or tin becomes waste.
 - Learners think about the route to the landfill of waste that is collected. If we run out of landfill space, we will pollute land and rivers with excess waste, affecting our drinking water and the quality of the food we eat. Birds, animals and indigenous plants will be affected.
 - Learners’ answers will vary. If we know how much and what types of waste we create, then we can plan to create less waste, and to recycle waste more efficiently. Municipalities can use the information to plan how much landfill space they will need. Waste buy-back centres can use the information for planning.

UNIT

7

DATA HANDLING

In this unit we will investigate data about waste and recycling. People who collect waste and deliver it to recycling businesses often work in the informal sector.

People who work to recycle waste help to conserve the environment while they are earning money. They are called “Green Entrepreneurs”.

An entrepreneur is someone who starts a new business.

7.1 Asking questions about a situation

- Suppose you are chosen to represent your town at a conference on recycling. At the conference you have to tell other people about recycling in your town. To be able to do this, you need information. Write down some questions about recycling in your town, for which you would like to have answers.

Since 2011, the Department of Environmental Affairs has been gathering information from municipalities about how they manage the waste that people create. All this information becomes **data** about waste management and recycling.

- Write down what you think “waste” is. How do things become waste?
 - Where does the waste end up where you are living? What do you think will happen if South Africa’s towns and cities run out of landfill space?
 - Do you think data about waste in your town or village can be used to plan better? Explain why you say so.

Waste is removed to landfill sites that are managed by the municipalities.

The table on the next page gives information about the waste that was produced by people living in the different provinces of South Africa in 2011. *Municipal waste* is the waste of *households, restaurants and shops*, but not the waste of factories or mines.

Possible misconceptions

The idea of “average waste per person” will be new for most learners. They may think that every person actually wastes the amount given. No one knows exactly how much waste was produced by any individual in different provinces; they only know the total waste produced and the number of people living in the province. The kilogram amounts given in the table are amounts calculated by dividing the total waste in any of the provinces by the total number of people in that specific province. For instance, the 113 kg of the Eastern Cape province indicates that people in the Eastern Cape produce on average 113 kg; some people will produce a lot more waste and others will produce less waste.

Mathematical notes

Part of data handling is using facts such as the numbers generated – for example the answers to questions 3(a) and (b) – as the basis for making an opinion, drawing conclusions or asking further questions. In general, the facts are used for further reasoning, as in question 3(c).

Teaching guidelines

Allow learners to share their answers to question 3(c), so that they can learn from each other.

Answers

3. (a) Western Cape, Northern Cape, Gauteng and Mpumalanga
(b) North West, Limpopo, Free State, Eastern Cape and KwaZulu-Natal
(c) Learners’ answers will vary; accept all reasonable answers. Some examples of answers are provided:
Provinces with many big cities, which have many shops and restaurants, may generate more waste per person than provinces that are more rural. (Northern Cape is an exception to this reason. Ask learners to think of a reason why this province generated such a large amount of waste per person).
It may also be that the wealthier provinces produce more waste than the poorer provinces.
Provinces with many tourists and migrant workers may show a large mass of waste per person. However, the tourists are not counted as *living* in the province. Similarly, it may be that not all people, for example migrant workers, who work and stay in a certain province (and therefore also generate waste in that province) are registered as living in the province and so they are not included in the calculation.

The sources of the information in the table are The South African Waste Information Centre and the Department of Environmental Affairs.

Municipal waste contributed by province in South Africa: 2011

Province	Average kilograms of waste per person in 2011
Western Cape	675
Eastern Cape	113
Northern Cape	547
Free State	119
KwaZulu-Natal	158
North West	68
Gauteng	761
Mpumalanga	518
Limpopo	103

3. Read the information in the table.
What does it tell you?
Answer the questions:
- (a) Which provinces generate high amounts of waste per person?
(b) Which provinces generate rather small amounts of waste per person?
(c) Write down some reasons why you think the waste contribution per person in the different provinces varies so much.

The waste per person is calculated as follows: The total mass of waste collected by all the municipalities in the province is calculated (added up). Then the total mass is divided by the number of people that live in the province. The kilogram waste per person in 2011 is the waste of the average person in 2011.

7.2 Drawing and interpreting graphs

Mathematical notes

Converting the data in the table on page 82 to a bar graph allows learners to see at a glance in which provinces the average waste generated per person is high and in which provinces it is low. Learners are asked to compare the data per province in two ways: firstly by finding the difference (subtracting) and secondly by finding how many times more one is than the other (multiplying or dividing). This lays the basis for working with pie charts. Pie charts also look at proportions of data in relation to each other.

Teaching guidelines

Prepare a frame of the bar graph and copies of the pie charts on the board or on posters to use during a class discussion.

Answers

1.

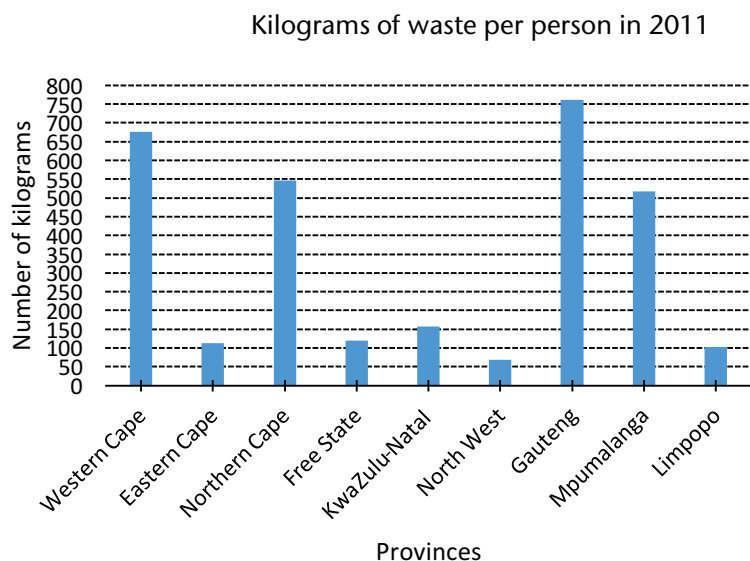

2. (a) Western Cape: about 675 kg of waste collected per person; Eastern Cape: about 113 kg of waste collected per person; $675 \text{ kg} - 113 \text{ kg} = 562 \text{ kg}$
The waste per person collected in the Western Cape was 562 kg more than the waste per person collected in the Eastern Cape.
- (b) The bar for the Eastern Cape fits almost seven times into the bar for the Western Cape. Therefore, on average, a person in the Western Cape generates almost seven times the amount of waste that a person in the Eastern Cape does.

7.2 Drawing and interpreting graphs

- Copy and label the axes and the heading below, and then complete the graph using the data in the table on the previous page.

Use the number line along the vertical axis to mark the numbers above each province. Then draw each bar from the bottom up to the correct height, in other words up to the marks that you have made.

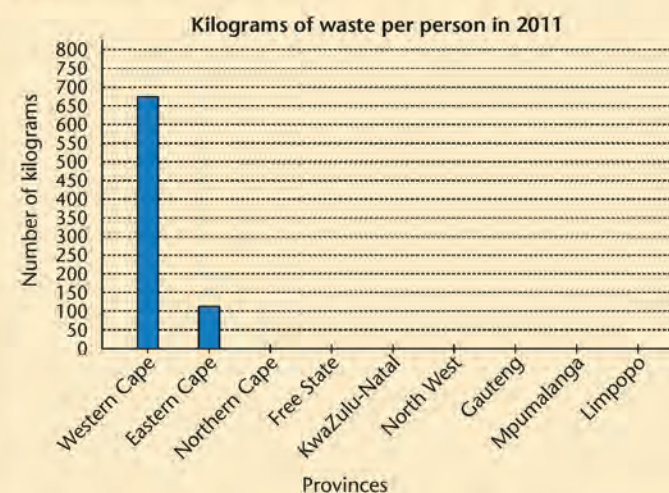

The number line where we can read the number of kilograms of waste per person is called the **frequency axis**.

- Compare the amount of waste per person in 2011 in the Western Cape and in the Eastern Cape.
 - Use the table to work out how much more waste per person was collected in the Western Cape than in the Eastern Cape.
 - Use your bar graph to say how many times more the waste per person collected in the Western Cape was than the waste per person collected in the Eastern Cape.

Teaching guidelines

Learners will have seen and interpreted fractions as sectors of a circle in the Foundation Phase. However, they may only have worked with examples where all the sectors in any circle are the same size. In question 4, each sector represents a different fraction (fifths, quarters, eighths, etc.). You can first let learners work with cut-out circles, which they fold into quarters. Then ask them to mark half and three eighths. Show learners a circle with a quarter and five eighths marked, and ask them to identify the fraction parts with reason.

In question 4 learners will have to approximate what fraction of the circle each sector is.

In question 4(e), learners may at first say the statement is false. You can then ask the class how they think builders' rubble could be at least partially recycled.

Answers

3. (a) Learners can compare any two bars, so their answers will vary. One example is provided here:
Northern Cape: about 547 kg per person; Free State: about 119 kg per person.
Therefore, a person in the Northern Cape generates about 428 kg more waste than a person in the Free State.
The bar for the Free State fits about four and a half times into the bar for the Northern Cape. Therefore, a person in the Northern Cape generates about four and a half times more waste than a person in the Free State.
- (b) Learners check each other's calculations and estimates.
4. (a) The green sector is about one fifth of the circle, therefore organic waste formed about one fifth of all municipal waste in the Western Cape in 2011.
- (b) The waste that could be recycled was between a quarter and a fifth of all municipal waste in the Western Cape in 2011.
- (c) The blue sector is about three eighths of the circle, so about three eighths of all waste in Gauteng in 2011 was waste that could not be recycled.
- (d) In Gauteng. The red sector represents recyclable waste: it is about one quarter of the circle.
- (e) True. Composting will eliminate the organic waste represented by the green sectors; recycling will eliminate the waste represented by the red sectors and some of the builders' rubble represented by the yellow sectors. Then it is only a little more than the waste represented by the blue sectors that will go to the landfills.

3. (a) Choose two other provinces to compare. Answer the same questions as in question 2 about the provinces you chose.
- (b) Work with a classmate. Think critically about the comparisons you made between the provinces. Make corrections if necessary.
4. The pie charts show different kinds of municipal waste collected in the Western Cape and Gauteng in 2011.

A **key** tells the meaning of the colours used in the pie chart.

Types of municipal waste collected in the Western Cape in 2011

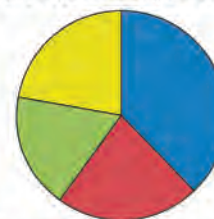

Key: ■ Non-recyclables ■ Recyclable waste
■ Organic waste ■ Builders' rubble

Types of municipal waste collected in Gauteng in 2011



Key: ■ Non-recyclables ■ Recyclable waste
■ Organic waste ■ Builders' rubble

- (a) Estimate the fraction of organic waste in the Western Cape in 2011: Is it less than a quarter or more than a quarter of all the municipal waste in the Western Cape?
- (b) Estimate the fraction of municipal waste in the Western Cape in 2011 that could be recycled.
- (c) Estimate the fraction of municipal waste in Gauteng in 2011 that could not be recycled.
- (d) In which province was the recyclable waste one quarter of the municipal waste in 2011?
- (e) Use the pie charts to decide whether the following statement is true or false. Explain how you made your decision.

Organic waste includes food waste and garden waste.

If we would make compost of all the organic waste and would recycle all the waste that we can recycle, the landfill sites in the Western Cape and Gauteng would have received only about half the waste that they received in 2011.

Teaching guidelines

Data handling is about making sense of large sets of data. In data representations the information is rounded to approximate values. Learners are used to working with exact answers in Mathematics and may resist working with approximations. Explain to learners that they have to find a scale where the rounding shows the relative size of the groups as accurately as possible. In question 6, let learners try out a scale of 25 and of 50 and discuss the amount of inaccuracy. Then let them try scales of 30, 20 and 10. Thirty is the most convenient rounding for the data, as it shows the relative proportions of the groups of waste pickers most accurately, and yet the bars are not too long. Learners must remember to always say “almost” when they read the frequencies from pictographs.

Answers

5. (a) Yes, the number of people who earn an income by recycling is slowly increasing. You can see this at a glance by looking at the pictograph. In 2009 there were about 35 000 workers and in 2014 about 50 000 workers.
 (b) 2011: about 40 000 people (c) 2013: about 45 000 people

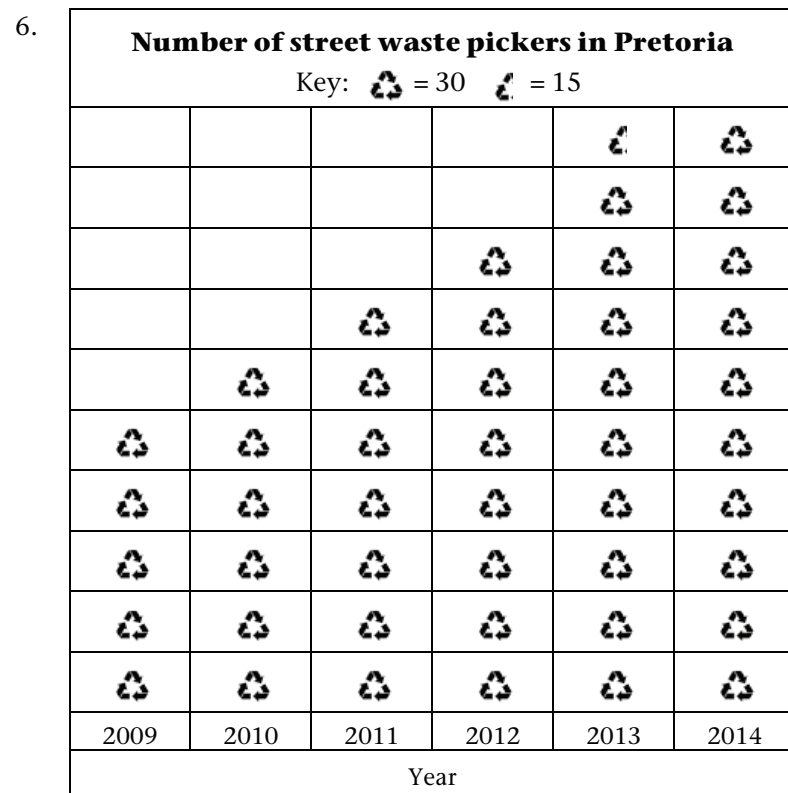

Learners can choose any sensible icon, such as stick figures for example, to represent groups of people. Some learners may use a scale of 1:10 or 1:20 instead of the scale of 1:30 used here.

5. The pictograph below gives a summary of the number of people who earn their income by recycling plastic. These people are informal workers.

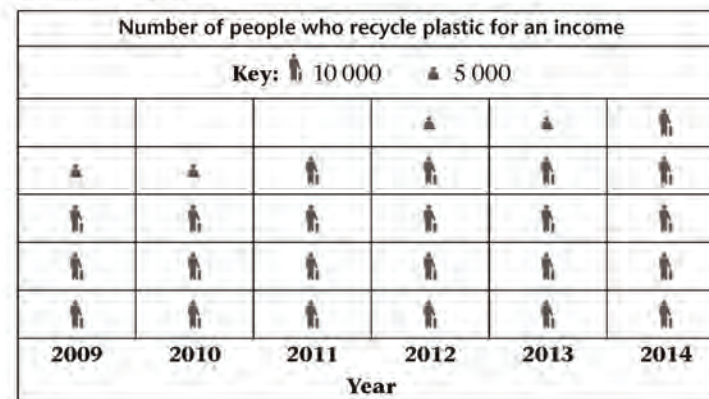

- (a) Look at the pictograph. Do you think the number of people who earn their income by recycling plastic is increasing? Explain why you say so.
 (b) Use the key to work out how many people earned their income by recycling plastic in 2011.
 (c) Use the key to work out how many people earned their income by recycling plastic in 2013.
6. The table below gives data about the number of street waste pickers that have worked in Pretoria since 2009.

2009	2010	2011	2012	2013	2014
154	185	215	235	289	301

Read the text on the next page about how to make a pictograph.

Make a pictograph to show the data in the table above.

Make sure your pictograph has a heading and a key.

A street waste picker collects recyclables from waste bins and sells it to buy-back centres.

Possible misconceptions

This may be the first time that learners work with pictographs with many-to-one representations. Some learners may not realise that each icon represents more than one data item. You may need to alert learners to the key. You can ask learners why each person in the information is not represented by one icon, i.e. why do icons represent *groups of people*.

7.3 Summarising and analysing data

Mathematical background

Graphs provide a visual image of data. Another way of analysing data is to look at the shape of the data, i.e. how spread out or clustered it is. Measures of data allow one to describe the spread and the centre of the data. In this section learners begin to examine the typical value or centre of the data by using the concept of mode. The mode of ungrouped numerical data is the data value that appears most.

In many areas of Mathematics there are one or more definite answers to questions or calculations. Data handling often involves a much higher degree of uncertainty. Reasoning in uncertain situations may make learners feel insecure, because they are not used to doing it. In data handling learners need to use their analysis of the data as evidence to back up an argument. In question 3 you may need to support learners to give reasons for their answers that they find in the data in the table.

How to make a pictograph

Step 1: Draw a horizontal line and mark it off in equal lengths. Write the years in the correct order below the line. This is the **category axis**.

Step 2: Decide on an icon (symbol) and on the number of people that your icon will represent. To do this, look at the size of your largest data value. You may choose a number such as 10, 20, or 30.

You may also make an icon that represents half the number you chose; for example, if you decided your icon will represent 30, then half your icon will represent 15.

Step 3: Round off the data values by counting in the number you chose. If you chose 30, count in 30s. As you count, write down the number closest to each data value. For example, if you count in 30s, then 150 is closest to 154.

Calculate the number of icons you need to represent the data for each year. For example, if your icon represents 30 people, you will need 5 icons to represent 150 people.

Step 4: Draw the icons neatly above each year. The icons must be arranged evenly so that you can see at a glance what the data tell.

7.3 Summarising and analysing data

Mrs Mmako works at a buy-back centre. She has to keep track of how much waste they receive and sort. They need the information to plan how much money to have on the site to pay the waste collectors who bring in the recyclable waste, and how many waste sorters they need. They also need to know when to arrange for recycling companies to collect full truckloads of sorted waste.

The buy-back centre is not open on Saturdays and Sundays, because they use those days to complete the sorting of the week's waste.

The table on the next page gives some of the buy-back centre's data. Mrs Mmako says the data are of a typical week.

If data are typical it means we can accept that they tell the story of what you can expect (more or less) when you look at any other week.

Teaching guidelines

You can begin by clarifying what a recycling buy-back centre is. You can also ask learners what kinds of information will help a recycling buy-back centre to run more efficiently and effectively. You can compare their answers with the information provided on page 86 of the Learner Book.

Completing the table in question 3 requires doing 20 calculations of the same type, i.e. adding four values. To save class time and prevent learners from getting bored, you can let different learners do different calculations. Let at least two learners do each calculation so that they can check each other's answers. It is more valuable for learners to add one group of numbers and check to find the reason for any mistake they might have made, than to ask all learners to do all 20 sets of addition.

There are some questions in this section that require calculations: these questions will have exact answers. However, most of the questions require learners to reason about the context and the data. In these questions learners' answers will vary. It is important to accept all reasonable answers, but it is more important that learners share these answers with each other, and that you allow time for learners to discuss these answers and to learn from each other.

Mass of recyclable waste received in Week 12

Day	Time	Mass of unsorted waste	Mass of sorted waste		
			Paper	Glass	Plastic
Monday	10:00	106 kg	21 kg	56 kg	29 kg
	12:00	100 kg	23 kg	52 kg	25 kg
	14:00	116 kg	41 kg	54 kg	21 kg
	16:00	78 kg	25 kg	41 kg	12 kg
Tuesday	10:00	114 kg	25 kg	49 kg	40 kg
	12:00	81 kg	24 kg	33 kg	24 kg
	14:00	94 kg	35 kg	40 kg	19 kg
	16:00	84 kg	34 kg	49 kg	1 kg
Wednesday	10:00	82 kg	25 kg	34 kg	23 kg
	12:00	91 kg	46 kg	40 kg	5 kg
	14:00	100 kg	31 kg	47 kg	22 kg
	16:00	115 kg	24 kg	58 kg	33 kg
Thursday	10:00	113 kg	23 kg	48 kg	42 kg
	12:00	101 kg	50 kg	41 kg	10 kg
	14:00	112 kg	30 kg	56 kg	26 kg
	16:00	92 kg	47 kg	45 kg	0 kg
Friday	10:00	101 kg	36 kg	38 kg	27 kg
	12:00	102 kg	50 kg	30 kg	22 kg
	14:00	117 kg	44 kg	60 kg	13 kg
	16:00	113 kg	32 kg	43 kg	38 kg

Answers

- Learners' answers will vary, for example: I wonder if she receives more waste on a Monday, i.e. after a weekend, than on other days? I wonder if she receives more glass than paper? I wonder if she receives more waste in the morning or in the afternoon? I wonder how much glass/paper/plastic she typically receives per day?
 - The sample questions in (a) can all be answered with the data. Three examples are provided:
To answer "I wonder if she receives more waste on a Monday, i.e. after a weekend, than on other days?": Compare the total amounts of waste that she receives each day. Draw a bar graph.
To answer "I wonder if she receives more glass than paper?": Compare the amounts of glass per day to the amounts of paper per day. Draw two bar graphs.
To answer "I wonder if she receives more waste in the morning or in the afternoon?": Compare the total amounts of waste received each morning with the total amounts of waste received each afternoon. Draw two bar graphs.

- 25 kg
 - There are four modes: 40 kg, 41 kg, 49 kg and 56 kg

Day	Total mass of unsorted waste	Total mass of paper	Total mass of glass	Total mass of plastic
Monday	400 kg	110 kg	203 kg	87 kg
Tuesday	373 kg	118 kg	171 kg	84 kg
Wednesday	388 kg	126 kg	179 kg	83 kg
Thursday	418 kg	150 kg	190 kg	78 kg
Friday	433 kg	162 kg	171 kg	100 kg

- On a Friday. It may be because the buy-back centre is in an area where people put out their bins on a Friday; it may be because the street waste pickers collect during the week and deliver on a Friday; it may be that more waste pickers deliver waste on a Friday than on other days. We need more information to be sure.
- They receive more glass on a Monday than on any other day. It may be that people drink more beer and wine over weekends and that there are more bottles to collect on a Monday. We need more information to be sure.

- Work with a classmate. Study the data in the table and think about waste collection. Write down some questions that start with "I wonder if ..."
 - Which of your questions can you answer with the data in the table? Explain how you will work with the data to answer the questions.

Mrs Mmako also asked "I wonder if ..." questions about her data.

She said: "I wonder if we tend to receive more glass than plastic. I will add up the mass of the sorted glass we got in the week and compare it with the total mass of the sorted plastic we got in the week. Then I will have an idea."

When we say "tend to..." we mean there may be a pattern for all the data together, although not every single data value will follow the pattern exactly.

- What is the mode of the amount of paper that was delivered in Week 12?
 - What is the mode of the amount of glass that was delivered in Week 12?

The **mode** is the value that occurs the *most*.

- Work with the data to complete the table, and answer the questions.

Day	Total mass of unsorted waste	Total mass of paper	Total mass of glass	Total mass of plastic
Monday				
Tuesday				
Wednesday				
Thursday				
Friday				

- On what day of the week does the buy-back centre typically receive the biggest mass of unsorted waste? Can you think of a reason why this is so?
- On what day of the week does the centre typically receive lots of glass? Can you think of a reason why?

Answers

3. (c) Plastic is lighter than glass. If you compare two bottles of the same size, the plastic bottle is lighter than the glass bottle. So, a trolley full of plastic will be lighter than a trolley full of glass.
4. Learners' answers will vary. One example could be:
On Monday the greatest number of waste pickers delivered waste: 25. On Thursday the smallest number delivered waste: 12. On both Wednesday and Friday 20 waste pickers delivered waste. On Tuesday 15 waste pickers delivered waste.

5. (a)

Day	Total mass of unsorted waste	Money paid
Monday	400 kg	R4 000
Tuesday	373 kg	R3 730
Wednesday	388 kg	R3 880
Thursday	418 kg	R4 180
Friday	433 kg	R4 330

She should plan to have about R4 500 available if this is a typical week. Some weeks may vary, but R4 500 is enough for 17 kg more than the biggest amount of waste this week.

- (b) No, it is very unlikely that the data will be exactly the same every week. The amounts of waste collected vary, the number of waste pickers that deliver vary, and the times at which they deliver waste to the buy-back centre vary. But if Mrs Mmako says this week is typical, then she means there is not much variation from week to week.
- (c) Amount paid: R4 000
Total number of waste pickers: 25
 $R4\ 000 \div 25 = R160$
On a Monday each person typically received about R160.

- (c) Why do you think the mass of the plastic that waste pickers bring in to the centre is generally lower than the mass of the glass?

4. Mrs Mmako also gathers data of the number of waste pickers that visit the buy-back centre every day to deliver recyclable waste. She made this bar graph with the data for Week 12.

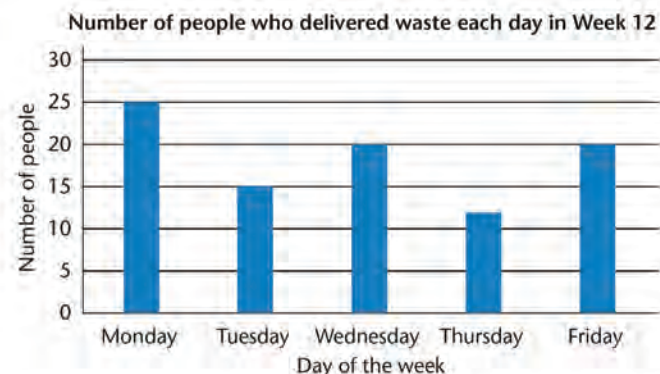

Write a short paragraph to interpret the information in the graph.

5. (a) The buy-back centre pays R10 per kilogram for unsorted waste (if the waste consists only of paper, glass and plastic). How much money must Mrs Mmako plan to have on the site every day of the week?
- (b) Do you think the amounts of waste will be exactly the same every week? Explain why you say so.
- (c) Work with the total amount that the buy-back centre paid for unsorted waste on Monday. Share the money evenly between the number of people who delivered the waste. How much money did they typically get for the waste they delivered on Monday?

7.4 Project

Teaching guidelines

This project will take about three weeks to complete. Learners must plan the project in the first week and inform the participants (people from whom the data is going to be collected). During the second week they must gather data by sorting and weighing the waste every day, and record the data. During the third week they must represent, analyse and interpret the data.

Week 1

Help learners with the following preparations:

- Make labels for the different containers that will be used to hold the waste.
- Talk to the school during assembly to inform them about the project.
- Find a suitable scale to weigh the waste.
- Prepare a data-collecting sheet (see assessment criteria below) that shows the day, the kind of waste and the mass.
- Form groups and decide who will gather and analyse data of different kinds of waste.

Week 2

- Help the groups to collect data about different kinds of waste.
- Help the groups to collect, sort and weigh the waste daily (remember to collect waste paper from the office too).

Week 3

- Share your assessment criteria with learners. For example:
 - Data gathering:** The data must be recorded daily in a table. (5 marks)
 - Data representation and analysis:** The data must be represented in bar graphs or pictographs. The graphs must have a heading, labels on the axes and/or a key. The scale must be correct. The bars must be drawn accurately. The graphs must be neat and easy to read. (10 marks)
 - Data interpretation and reporting:** Each group must write a report to say what questions they wanted to answer, how and where they gathered the data, and what they found. (10 marks)
- Provide learners with paper to draw the graphs.
- Arrange for learners to present their findings to each other, or to an audience of schoolmates and teachers.

Resources

Containers for waste collection; a scale to weigh waste; data-collecting sheets; paper to draw graphs (see Addendum, pages 413 and 414)

7.4 Project

Gather data about the amount of recyclable waste on your school grounds or at your house. You must gather *at least* one week's data.

Step 1: Set up the project

Label different containers for recyclable waste, organic waste and non-recyclable waste. Ask your Natural Sciences teacher to help you understand what kinds of waste should go where.

Inform the other learners in the school (or your people at home) about your project and ask them to dispose of their waste in the correct bins.

Step 2: Gather data

Decide whether you want daily data or weekly data. Weigh the bags with waste at the same time of day, for example after the last period or after sports practice.

Decide whether you want to gather data about specific kinds of recyclable waste. If so, sort the waste so that you can weigh the different kinds of waste (for example paper, glass, tins, and plastic) separately.

Step 3: Represent and analyse the data

Use your knowledge of data handling to draw pictographs or bar graphs of the data.

Step 4: Interpret and report the data

Write a report of your findings. Make recommendations to the school or to your family about working together to recycle waste. If you can, use the internet to find out about waste recycling projects in your area.

Learner Book Overview		
Sections in this unit	Content	Pages in Learner Book
8.1 Curved and straight lines	Lines are essential parts of all shapes	91 to 93
8.2 Figures with different shapes	Identifying and naming polygons by counting the number of sides	94 to 96
8.3 Angles	Angles are used to compare the orientations of pairs of straight lines	97 to 98
8.4 Right angles around us	Right angles occur when two lines cross to form four equal angles	99 to 100
8.5 Angles and sides in two-dimensional figures	Comparing shapes by comparing lengths of sides, and angles	101 to 103

CAPS time allocation	7 hours
CAPS page references	21 to 22 and 147 to 149

Mathematical background

Figures are made up of curved and straight lines. The lines may be connected, or not, to form closed or open figures. The lengths of the lines may vary within a figure and also from figure to figure. The directions that lines face (orientations of lines) vary within a particular figure and also from figure to figure. We use the concept of angle to compare the orientations of pairs of straight lines. Length and angle size are the basic quantities we use in geometry.

Both length and angle are measurable quantities. Learners go through four stages when learning to measure:

1. **Identifying and understanding the property they are measuring**
Most Grade 5 learners know when they are measuring length, mass or capacity/volume. Angle, however, is a new measure and most learners struggle to understand what they are measuring when they first encounter angles. Spend time developing the concept of angle.
2. **Comparing and ordering examples of a particular measure** (see questions 1 and 2 of Section 8.4)
Instead of measuring angles, learners are asked to compare different angles between straight lines. This is to allow them the opportunity to develop a feel for the sizes of angles. Learners who can say “This angle is bigger than that angle” with the same confidence as when they say “This line is longer than that line” will be in a very strong position when they eventually begin to measure angles. In this unit learners first compare angles by sight.
3. **Using informal or non-standard units to measure** (see question 6 of Section 8.4 and question 2 of Section 8.5)
In this unit learners make templates of angles and use them to check whether angles are the same size or not.
4. **Using formal or standard units to measure**
Measuring with formal or standard units allows many people in many different places to measure, quantify and compare measurements using the same measure. Learners will measure angles with protractors from Grade 7 onwards.

The aim is to develop an understanding of what an angle is, and what does and does not affect the size of an angle, before working with formal instruments to measure angles in later grades. Without this focus on **angle concept**, many learners may never understand what an angle is. In this unit many of the activities must be allowed to be learner driven.

8.1 Curved and straight lines

Mathematical notes

There are two basic kinds of lines: straight lines and curved lines. Curved lines may be parts of circles, or they may not.

This section is an informal look at straight lines and curved lines. When we speak of these types of lines we usually *mean* smooth lines. There are also “lines” that are not smooth. They may look straight or curved as a whole, but they may be quite crooked close-up. The lines we attempt to draw freehand may not be smooth; they may be rather crooked.

Teaching guidelines

If possible, encourage learners to find interesting examples of shapes made up of curved lines and straight lines.

You can begin by asking learners: “*What kinds of lines do we find in the shapes around us?*”

For enrichment (you may decide if the time is ripe for your learners to explore a bit further) you may ask your learners a question like: “*Is a crooked line crooked everywhere?*” or “*Can we imagine a crooked line as many tiny straight or curved lines?*”

Drawing lines helps to focus learners’ attention on the features of the lines. In this section learners are asked to draw various curved and straight lines freehand. Often our skill at representing our ideas in diagrams does not do those ideas full justice. So, when your learners draw freehand straight lines and freehand circles, encourage them to do so as neatly as they can, but do not allow them to spend too much time on each line or circle. We often draw freehand sketches to explain something to someone else. Everyone agrees that the not-so-smooth straight and curved lines we draw represent perfectly smooth straight and curved lines in our heads.

UNIT

8

PROPERTIES OF TWO-DIMENSIONAL SHAPES

8.1 Curved and straight lines

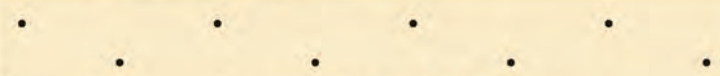



You can join dots such as these with **straight lines**:



You can also draw a **curved line** that passes through the dots:







Rock artists used both curves and straight lines in their art.

GRADE 5: MATHEMATICS [TERM 1]91

Notes on questions

Curved lines may or may not be parts of circles. In question 1 there are two shapes with curved sides and two shapes with four straight sides. Drawing lines helps to focus learners' attention on the kind of line (in these examples straight or curved). Seeing shapes within shapes is a useful skill: learners will use this skill often when they do FET geometry.

Answers

- (a) Learners' own freehand drawings of the two circles of different sizes
(b) Learners' own freehand drawings of the two squares of different sizes and with different orientations

A South African artist used straight lines and curves to make this painting.

These are some of the curves she used:

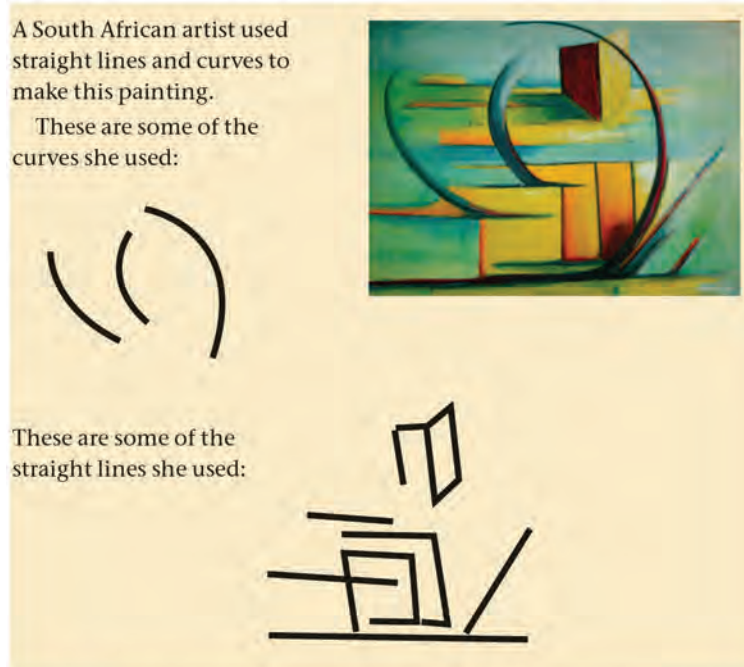

These are some of the straight lines she used:



- (a) Make a rough drawing of the curved parts of the diagram on the right.
(b) Make a rough drawing of the straight line parts of the diagram on the right.

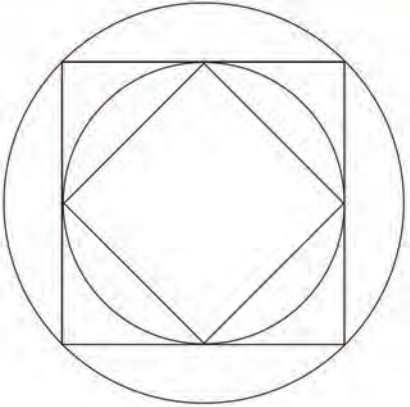

92 UNIT 8: PROPERTIES OF TWO-DIMENSIONAL SHAPES

Notes on questions

The picture of a curve drawn over rectangles in question 2 is used to focus learners' attention first on curved lines and then on straight lines.

One kind of spiral is shown on page 93 of the Learner Book. There are other kinds of spirals. An example is shown alongside.

The only requirement for a spiral is that, as it continues to spiral (widen), the line becomes longer and moves further away from the starting point at the centre of the spiral.



Answers

2. (a) Learners' freehand drawing of a spiral. It does not have to be the same kind of spiral as the one shown on page 93.
- (b) Learners' freehand drawing of the blue lines that make up the eight rectangles, i.e. they copy the blue diagram but not the red spiral on it.
3. Learners' freehand drawing of lines
4. Learners' freehand drawing of circles

2. The red curve in the drawing on the right is called a spiral.
 - (a) Make a drawing of a spiral, without any straight lines on your drawing.
 - (b) Make a drawing of all the straight lines in the drawing, without the spiral.

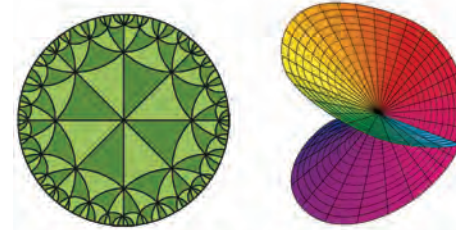
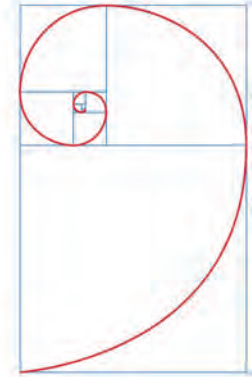

Two more examples of drawings with curves and straight lines

Make some freehand drawings

3. Try to draw a straight line without using a ruler. Try to do it better than the line below has been drawn.



If you draw two lines close to each other, you can see which one is a better attempt to draw a straight line.



4. Try to draw a circle without using a cup or glass or saucer or other guide. Some attempts are shown below.



8.2 Figures with different shapes

Mathematical notes

Two-dimensional figures are characterised by

- the number of sides they have,
- whether the sides are straight lines or curved lines,
- the lengths of the sides, and
- how the sides are oriented towards each other at the places where they join (i.e. the size of the angle between them).

In the Intermediate Phase, learners begin to focus on the properties of shapes. When we group shapes according to their properties, we call it classifying shapes.

Notes on questions

Question 1 draws learners' attention to angles. The concept of angle is introduced informally here. This is further explored in Sections 8.3, 8.4 and 8.5. Question 2 continues the focus on straight and curved lines. Question 3 focuses on open and closed figures. In questions 4 to 8 and Section 8.5 learners work with closed figures and their shapes.

Teaching guidelines

Encourage learners to begin thinking about the properties of shapes and how different shapes are related to each other. Drawing figures and talking about their shapes is a way to start.

You may open the section with a few questions that will help learners to compare shapes and, in so doing, to group and classify them. The following two questions may be useful: "What do these figures have in common?" and "In what way do the figures differ?"

It is advisable to view this section as being about more than just its contents. Focus also on the process of organising and classifying.

Answers

1. (a) to (c) Learners' own freehand drawings of the angles
2. (a) to (b) Learners' own freehand drawings of the shapes
3. Open figures: A and C
Closed figures: B and D

8.2 Figures with different shapes

1. Draw figures with shapes like these. Do not use a ruler but try to make the lines as straight as you can. Do not lift your pencil at the corners.

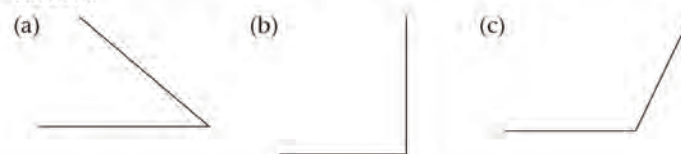

In each of the figures that you have drawn above, two straight lines meet. When two straight lines meet, we say an **angle** is formed.

2. Draw figures like these. Do not lift the pencil before the drawing is finished.

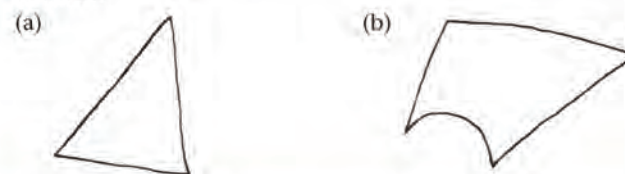

The figures that you have drawn in question 2 are called **closed figures**.

The figures that you have drawn in question 1 are called **open figures**.

3. Which figures below are closed, and which are open?



Teaching guidelines

In question 4 learners will classify the figures by looking only at their number of sides. You may find that some learners lose focus and start looking at other properties of the figures. If so, help them to return their focus to counting the number of sides of each figure.

Learning to focus on specific things when there are many things that may grab our attention is a very important skill in Mathematics and in life. Generally, refocus learners' attention on the particular characteristic under discussion whenever they blur different characteristics and lose focus (e.g. if they muddle up length and angle size when asked about only one of these).

Possible misconceptions

Sometimes when learners see figures that look like stars, they count the pointers of the stars instead of counting the sides of the figures. If learners incorrectly call Figure G in the Learner Book a pentagon or Figure I a quadrilateral, then they have counted the number of pointers and not the number of sides. You can ask learners that make this mistake to draw larger versions of these figures, and to count the sides as they draw them.

Answers

4. (a) Triangles: H
(b) Quadrilaterals: B, D, M, S, U
(c) Pentagons: A, O, P, Q
(d) Hexagons: C, F, K
(e) Heptagons: E, J, L, N, R, T

Closed figures with *five* straight sides are called **pentagons**.

“Penta” means five.

Closed figures with *six* straight sides are called **hexagons**.

“Hexa” means six.

Closed figures with *seven* straight sides are called **heptagons**.

“Hepta” means seven.

4. Write down the letters of all the figures that have the shapes of:

- (a) triangles
(b) quadrilaterals
(c) pentagons
(d) hexagons
(e) heptagons.

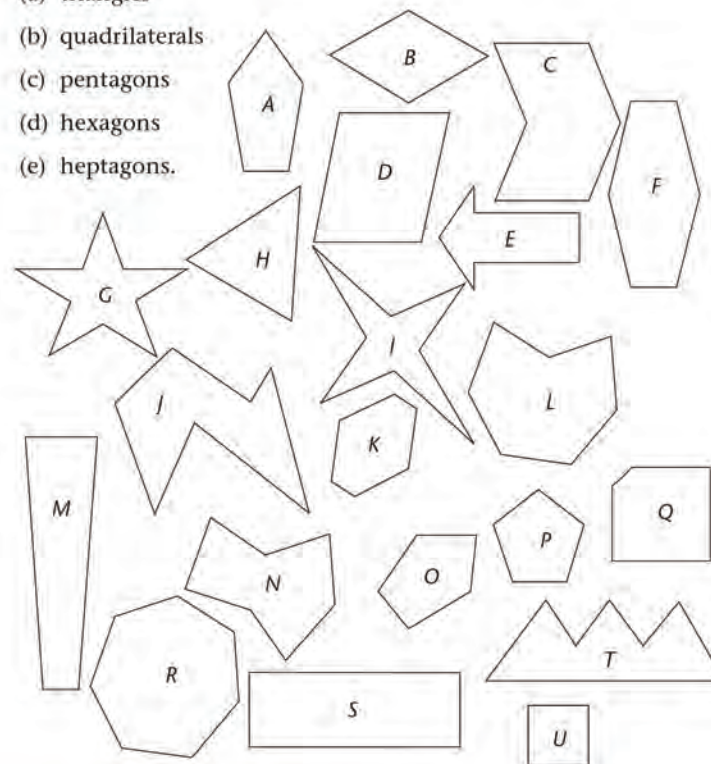

Teaching guidelines

In questions 5, 6, 7 and 8 you can start by asking learners to talk about “*What is the same in all three figures?*” This will consolidate the fact that we name polygons according to their number of sides. However, now they will also need to think about the lengths of the lines and the sizes of the angles. Let learners puzzle this out themselves.

Notes on questions

Questions 5 to 8 anticipate the work that learners will do on angle size and side length in Section 8.5. You might like to read ahead to that section.

Intermediate Phase learners are exposed to both irregular and regular shapes. Learners are expected to recognise two-dimensional shapes, whether they are irregular or regular. Question 4 on page 95 of the Learner Book is a good example of the range of each kind of shape that learners are expected to recognise and name. Irregular shapes are the more general form. Learners are not examined on either the definition of regular shapes or the ability to distinguish regular from irregular shapes. You will notice that they are not expected to do either in this unit.

This section ends with a definition of regular polygons, and the red figures are examples of these. This definition is intentionally left to the end of the section because it is not a focus in the unit.

Possible misconceptions

Learners may have the regular two-dimensional shapes (like those in red) in mind when they are asked to make decisions about the characteristics or names of figures they are shown. For example, they may recognise only the red figure in question 7 as a pentagon. They may say that irregular pentagons are not pentagons (e.g. the black figures in question 7 or pentagons that are shaped like an outline of a house: ). In such cases remind learners that the **naming** is about the **number of sides**, not about the orientations or lengths of sides.

For a polygon to be regular, both the following conditions must be met: all the sides must be the same length and all the angles must be the same size. If only one of the conditions is met, a figure will not be regular. A square is regular because all its sides are the same length and all its angles are right angles. A rectangle is not regular because although all its angles are right angles, all its sides are not the same length. A rhombus is not regular because although all its sides are the same length, all its angles are not the same size.

Answers

5. to 8. Different side lengths and different angle sizes

5. These figures are all triangles. How are they different?

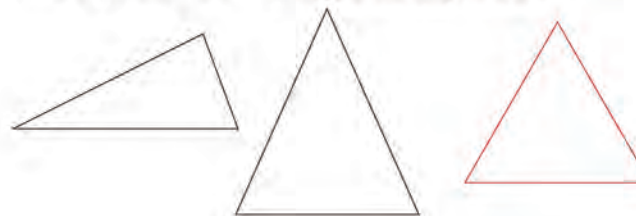

6. These figures are all quadrilaterals. How are they different?

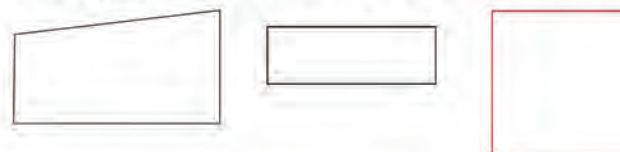

7. These figures are all pentagons. How are they different?



8. These figures are all hexagons. How are they different?

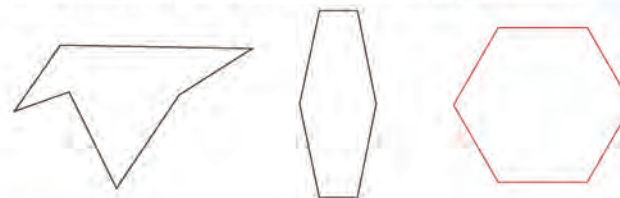

The red figures above are called **regular polygons**. All their sides have the **same length** and all their angles have the **same size**.

8.3 Angles

Mathematical notes

The idea of angle can only be properly understood with reference to the ideas of direction and rotation (turn). Two lines that do not have the same direction are said to be at an angle to each other.

The difference between the directions of two lines can be measured in terms of how much you have to turn the one line to make its direction equal to that of the other line.

Only when the *concept* of angle is grasped does the need to be able to measure angles become important. Resist the temptation to talk about degrees or to focus on using protractors; learners will get to this in Grade 7. Focus on developing the *concept* of angle.

Teaching guidelines

You can let your learners experience angles as *changeable* things (i.e. variables). The examples of opening a door, lifting an arm and opening a book will help fix this idea in learners' minds. Ask them simple questions such as "Is the angle getting bigger or smaller?" and "Describe how the angle is changing" while a door or book is being opened or closed, or a volunteer lifts or drops a straightened arm.

You can also use two sticks to show the concept of angle described in the first paragraph of the "Mathematical notes" above, or let learners work with two strips of cardboard (see the Grade 6 Learner Book, page 93).

Possible misconceptions

The angle concept is one of the most troublesome in school mathematics. Many learners go on to tertiary education without a meaningful grasp of what an angle is. The most common misconception is that an angle is somehow a length measurement.

There are two ways you can try to avoid or change this misconception. One way is to give learners a set of cut-outs of shapes of different sizes, but ensure that they all have the same angle at one corner. First ask learners whether, just by looking carefully, they think the angles are the same or not. Then ask learners to put the shapes on top of each other to confirm they have the same angle. Another way is to have a volunteer stand with his one arm extended and raised away from his side to form an angle between his arm and upper torso. Ask the volunteer to keep his arm in a fixed position. Place a straight stick or ruler in his hand and ask learners if the angle has changed. Place another stick/ruler along his side and ask the same question again. As long as the volunteer keeps very still, the angle between his arm and torso is unchanged.

Answers

1. Learners' descriptions of angles in the classroom will differ from class to class.



8.3 Angles

You can see many angles in your environment, for example:

- The edges of a page form right angles.
- An open door is at an angle to the door frame.
- Two walls form an angle where they meet.
- A broom against a wall forms an angle with the floor and with the wall.
- If you lift your arm there is an angle between your body and your arm.



1. Describe other angles in your surroundings.

When you open a book, the two opposite pages form an angle with each other.

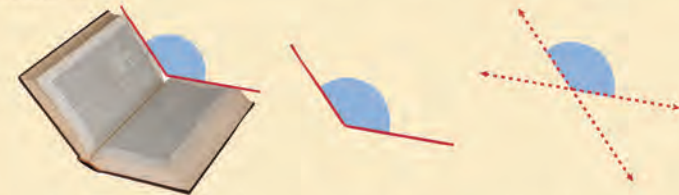

When two lines meet to form an angle, you can imagine the lines going on so that four angles are formed. The red **arcs** below show two of the four angles:



The arrowheads mean the lines can be as long as you want them to be, the angles stay the same.

Answers

2. (a) to (f) Learners' own drawings of lines and arcs to show angles. Some examples are shown below.

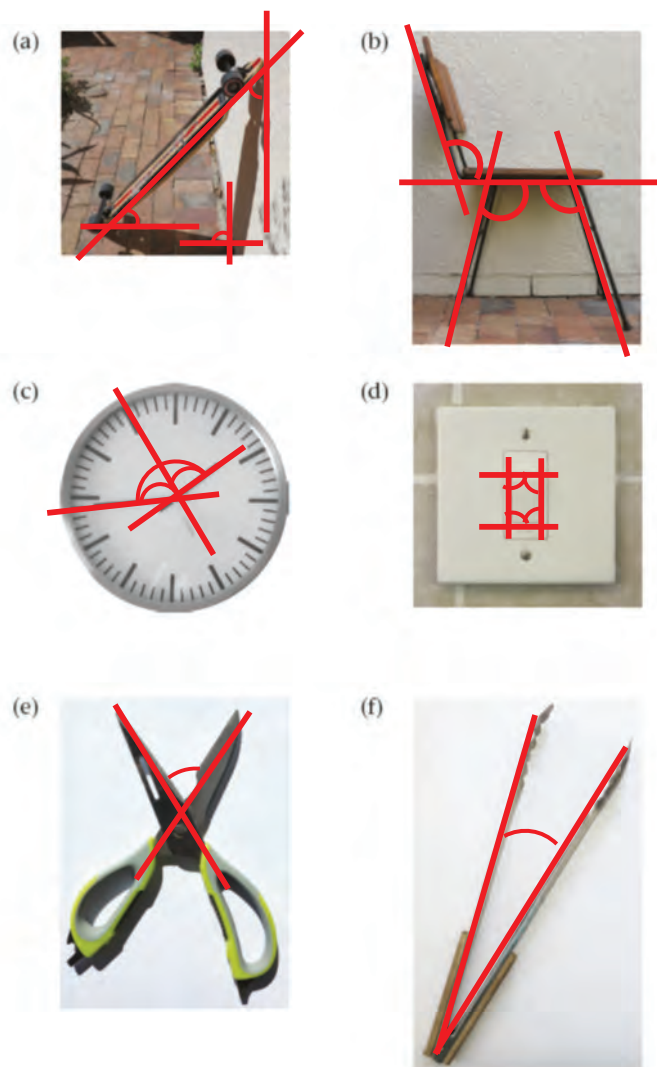

2. There are angles in the pictures below. Make simple but neat drawings of the lines that cross to form the angles. Draw arcs to show the angles.

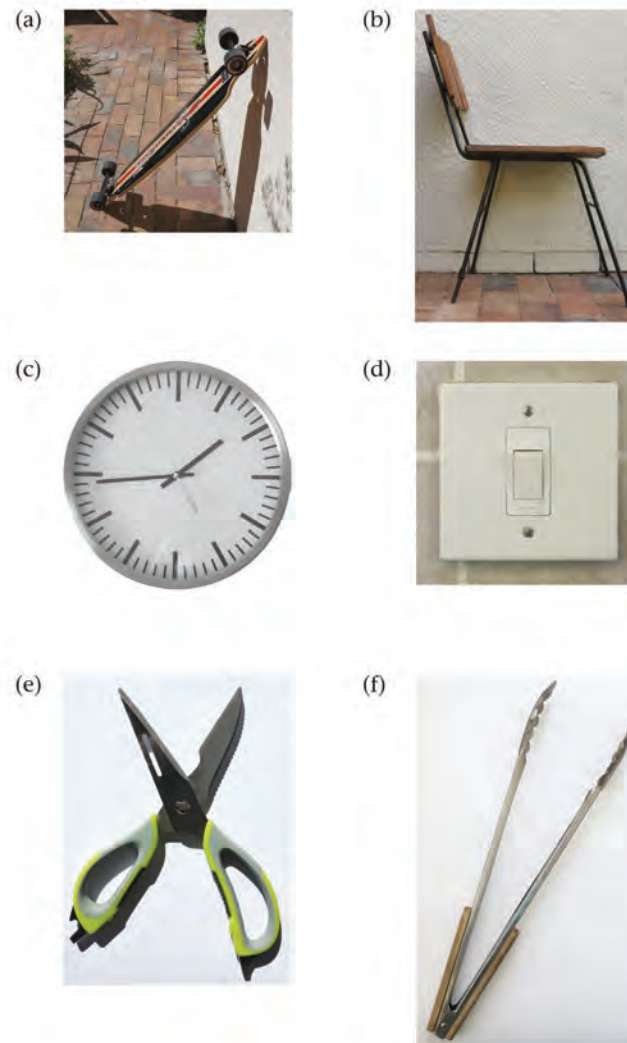

8.4 Right angles around us

Mathematical notes

Right angles are important references in geometry. If you can recognise a right angle, then you know whether an angle is bigger or smaller than a right angle. So recognising right angles helps learners to distinguish acute angles from obtuse angles from Grade 6 onwards. It also helps learners to know that they have read the correct scale on a protractor when they start using protractors in the Senior Phase.

Right angles also play a very important role in applications of mathematics in the construction industry, in woodwork, and so on.

The right-angle template is a *tool*. It allows us to decide whether a given angle is a right angle or not. This is the germ of the idea of measuring angles. To measure the size of angles we need some sort of reference instrument. The right-angle template is simply a special reference instrument for right angles. The idea of making templates for other angles arises in the next section.

Teaching guidelines

You can use the summary paragraphs and related sketches to show learners that when two lines cross and make four angles of the same size, we call these angles right angles. You can then demonstrate how to fold a right-angle template. Ask learners to walk around the classroom and find three angles: one right angle, one angle smaller than a right angle, and one angle bigger than a right angle.

When learners do question 2, ask them not to copy the sketches on page 99. They should rather draw two lines that form different angles than those in the sketch when they cross.

Answers

1. and 2. Learners' own freehand drawings

8.4 Right angles around us

These two lines form four **right angles** where they cross. We call the angles right angles because all four angles are the same size. We say the lines are **perpendicular to each other**.



These two lines do not form right angles where they cross. All four angles are not equal.

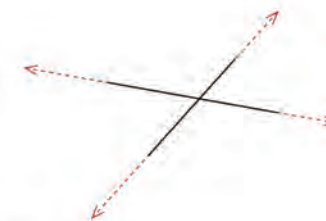

1. Draw two lines that cross at right angles.
2. Draw two lines that do not cross at right angles.
 - (a) Mark the angles that are smaller than a right angle.
 - (b) Use a different way to mark the angles that are bigger than a right angle.

Make your own right-angle template

Take a piece of paper. Fold it once. Make sure you fold a sharp edge. Fold it again so that the first fold line folds onto itself.

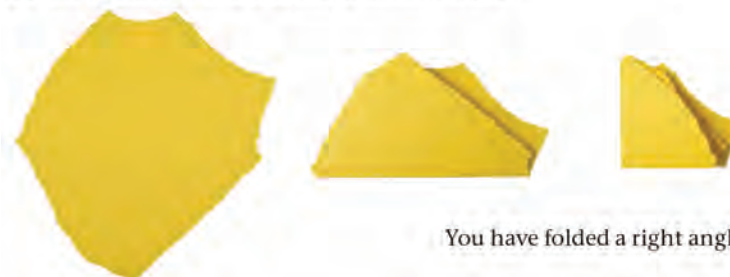

You have folded a right angle.

Teaching guidelines

Make a plumb line in class and demonstrate how it can be used to check whether a cupboard stands upright.

Answers

3. Check with a right-angle template whether the angle between the table top and the plumb line is a right angle.

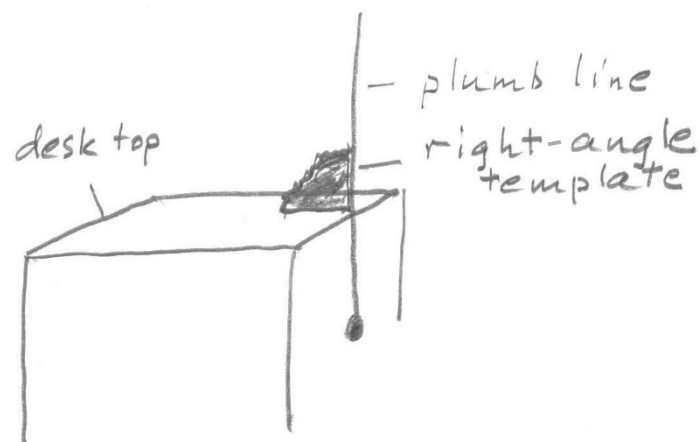

4. Monitor learners' practical activity.
5. Monitor learners' practical activity.
6. (a) to (c)

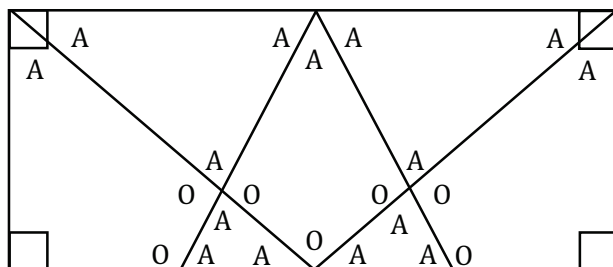

Make your own plumb line

Tie a small, heavy object such as a washer (or a small flat stone) to the end of a piece of string. Hold the string so that the object (called a plumb bob) hangs free. When the plumb bob stops swinging the string hangs vertically. A line that is perpendicular to the plumb line is a horizontal line.



3. Use your plumb line to test if the top of your desk is horizontal. Explain and make a drawing to show how you judge.
4. Use your right-angle template to test if two walls in your class meet at a right angle.
5. Use your plumb line to determine if the door frame in your class is vertical.
6. Draw this diagram in your book. Use your right-angle template to test if the angles are smaller than a right angle, or bigger than a right angle, or the size of a right angle.

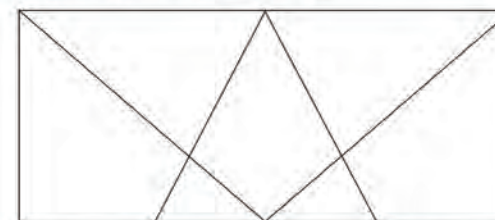

- Mark all the right angles in the diagram with a box, like this: \square
- Mark all the angles that are smaller than a right angle with the letter A.
- Mark all the angles that are bigger than a right angle with the letter O.

8.5 Angles and sides in two-dimensional figures

Mathematical notes

This section brings together the ideas of line size (length) and angle size. The idea of an angle template for any angle is also explored.

Teaching guidelines

Learners are asked to make comparisons of angles and lengths in a number of figures, and to draw conclusions about their shapes. To do this meaningfully, they need a way of showing that one angle is smaller than another, or that one line is longer than another. In all cases, the only way to be certain is to have a reference tool. Encourage learners to find ways of checking using tools. Sheets of paper can be used to fold or cut out **angle templates**. Explain to learners that, unless the angle template they make fits exactly on the angle in the given figure, they are not working accurately.

Be aware that learners are never asked to give the lengths of any of the sides of the figures. It may be best not to use a ruler to measure line lengths at first, but rather to mark off lengths on the edge of a sheet of paper – a **length template**. This will establish a conceptual link with the idea of individual angle templates, which are either folded or cut out to be exactly the same as a given angle.

For questions 1 and 2, it will help learners if one learner has the Learner Book open on page 101 and the learner next to them has it open on page 102. This will allow learners to read the questions and see the figures at the same time, instead of trying to keep the questions in their heads while they turn the pages to see the diagrams.

Notes on questions

In question 1, ask learners to look at the figures in the Learner Book when they answer the questions about the angles and to *only* use their own drawings for writing down what they have decided (their own drawings are unlikely to be very accurate).

Answers

- (a) and (b) All angles are smaller than right angles and should be marked with A.
(c) and (d) All angles are right angles and should be marked with \square .

Possible extension

When learners are asked to draw copies of given figures it is unlikely they will make very accurate copies to begin with. Allow them to work in small groups to compare how well they have copied particular figures. It is very likely that there will be some variation between their individual efforts. This raises the important questions: “How can we decide if my copy is good?”, “How can we tell if her copy is better than his?”, “How do we make sure that my copy is an exact copy?”, etc. The key is to make angle and length templates.

8.5 Angles and sides in two-dimensional figures

- Draw each figure in your book. Name the figure, then compare the sizes of the angles. Mark the angle with a \square if you decide it is a right angle. Write A in the angle if the angle is smaller than a right angle. Write O in the angle if the angle is bigger than a right angle.

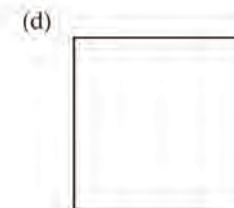
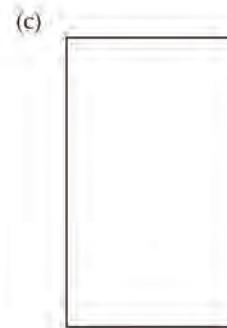
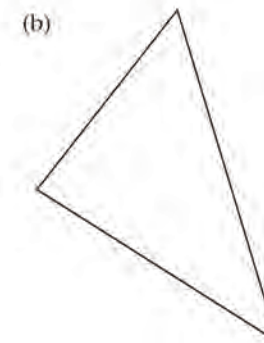
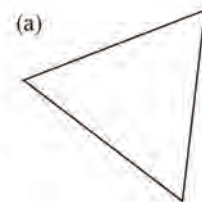

Notes on questions

In question 2 (as in question 1), learners have to base their decisions on the figures in the Learner Book, *not* their own drawn figures, which are unlikely to be exact copies of the given ones.

Answers

- (e) No right angles. The angles at the top left and bottom right of the figure are bigger than right angles. The angles at the top right and bottom left are smaller than right angles.
(f), (g), (h): No right angles. All the angles are bigger than right angles.
- (a) Figures with equal-length sides: (a), (d), (f), (g)
(b) Figures with equal-size angles: (a), (c), (d), (f), (g)
- (a) Learners' own work: the other two angles will be smaller than right angles.

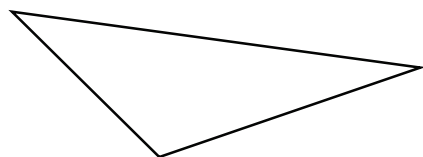

- (b) Learners' own work. It is impossible to draw a triangle with two angles bigger than right angles because the lines/sides will never meet (i.e. a closed figure cannot be formed).

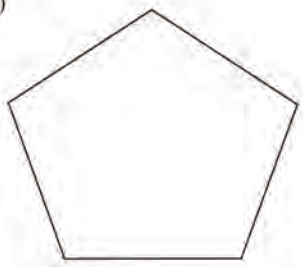

(e) 

(f) 

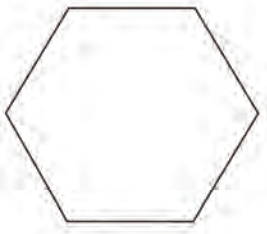
(g) 

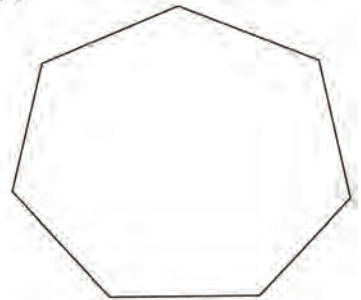
(h) 

- Compare the figures in question 1.
 - Which of the figures have sides that are all the same length?
 - Which of the figures have angles that are all the same size? Make angle templates to help you decide.
- Draw a triangle with an angle that is bigger than a right angle. Look at the other two angles of your triangle. Are they smaller or bigger than a right angle?
 - Try to draw a triangle with two angles that are bigger than right angles. Explain what happens.

102 UNIT 8: PROPERTIES OF TWO-DIMENSIONAL SHAPES

Notes on questions

Note that question 5 refers back to question 1 (page 101 of the Learner Book), not to question 4 (page 103). It may help learners if one learner has the Learner Book open on page 103 and the learner next to them has it open on page 101.

You could also ask learners to identify which figures in question 4 are squares, which are rectangles and which are parallelograms. Here you can check whether learners are able to identify squares when their sides are not parallel to the sides of the page. The letters of the alphabet p, q, d and b all have the same shape, but are considered different because they face different directions. Sometimes learners think that if shapes face a different direction they are different shapes. This misconception often happens with squares. The shapes below are all squares.

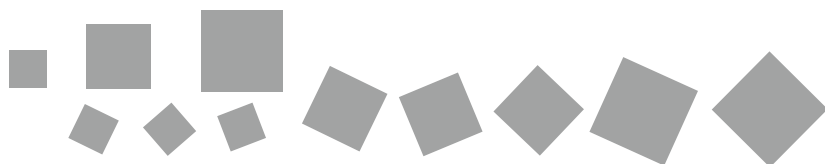

It is important that learners see the same shapes in a range of different positions. You can cut a piece of card into the shape of a square. Place it against the board and trace around it. Move it to a different place on the board and turn it so that no side is parallel to the edges of the board. Repeat this several times. Each time ask learners to identify the shape that you have drawn. Ask them whether the properties of the shape have changed.

Question 6(b) anticipates the work that will be done in Term 3. You might like to read the notes for Section 6.2 in Term 3 Unit 6 of this Teacher Guide.

Answers

4. (a) The blue and black quadrilaterals have right angles only; the red quadrilaterals have no right angles.
(b) The black and blue figures are similar in that all their angles are right angles. They are all quadrilaterals. They all have straight sides.
(c) The black figures have four sides of equal length. The blue figures have two pairs of opposite sides with different but equal lengths.
5. (a) Squares: Figure (d)
(b) Rectangles: Figures (c) and (d)
6. (a) No, all rectangles are not squares.
(b) Yes, all squares are rectangles.

4. (a) How do the blue and black figures on the left differ from the red figures on the right?

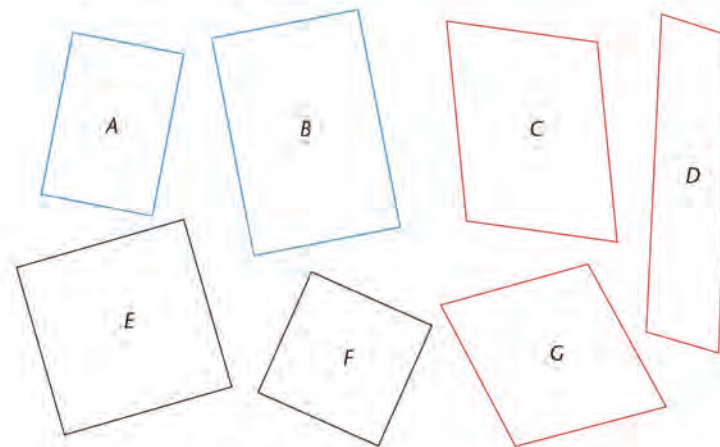

- (b) In what way are the two black figures similar to the two blue figures?
- (c) In what way are the two black figures different from the two blue figures?

If all the angles of a quadrilateral are right angles, it is called a **rectangle**.

If the four sides of a rectangle have the same length, it is called a **square**.

5. (a) Which figures in question 1 are squares?
(b) Which figures in question 1 are rectangles?
6. (a) Are all rectangles also squares?
(b) Are all squares also rectangles?

Learner Book Overview		
Sections in this unit	Content	Pages in Learner Book
9.1 Capacity and volume	Understanding the difference between capacity and volume	104 to 106
9.2 Make a measuring jug	Using small units of volume to make a scale on a bottle, to measure any volume that can fit in the bottle	107
9.3 Litre and millilitre	Learning about the units for measuring volume and capacity	108 to 110
9.4 Calculations and problem solving	Using the concepts of volume and capacity in different contexts	110 to 111

CAPS time allocation	5 hours
CAPS page references	26 and 150 to 153

Mathematical background

- The term “volume” is used to indicate how much space is taken up by an amount of liquid or other form of material, or by an object.
- The term “capacity” is used to indicate how much space is available in a container, irrespective of how much of the space is taken up at a given moment.
- The same units of measurement are used for volume and capacity.

Though the capacity of a cup or the volume of a liquid is given in litres and millilitres, these units are based on cubic units. The millilitre is really the cubic centimetre.

Length we measure in straight centimetres. Area we measure in centimetres \times centimetres (cm^2 ; draw yourself a square with each side 1 cm long). Volume we measure in centimetres \times centimetres \times centimetres (cm^3 ; draw yourself a cube, like the one you see on page 105 of the Learner Book; each side is 1 cm long).

A litre is really 1 000 of these little cubes. If you packed 1 000 of the little cubes together you would get a bigger cube, 10 cm \times 10 cm \times 10 cm in size. (Draw this for yourself.) The volume of that cube is one litre. So, one litre is 10^3 cubic centimetres or 1 000 cubic centimetres.

If we take the litre as our standard unit of volume, then the small unit is the millilitre. So 1 ℓ has the same volume as 1 000 ml.

Resources

A tall, narrow glass and a short, wide glass; eight identical glasses; four glasses with the same height but different diameters; 1 ℓ coloured liquid (e.g. tea or cooldrink or water coloured with food colouring); four or more standard teacups; a 1 ℓ container; water; sand; plastic bottles, identical glasses or jars, etc. – see Section 9.2

9.1 Capacity and volume

Teaching guidelines

This unit deals with liquids and the volumes of liquids, but do not treat it as something strange and different to the mathematics the learners already know. Everything they have learnt, including fractions, division and scales on measuring instruments, is going to be useful.

Possible misconceptions

Many young learners will say that the glasses in question 1 contain the same volume of water, and in question 2 that the glass at the beginning of the row contains more than the glass at the end of the row. They look only at the *height* of the water and do not think about the *diameter* of the glasses. Later on, they will begin to realise that the *diameter* of the glass is also important, and that they must consider both *height and diameter*. When learners consider both dimensions, by themselves and without you telling them, they have developed a new cognitive ability.

Not all learners, even in high school, have this thinking ability, but you can help them to develop it. Do this practically with a tall, narrow glass and a short, wide glass. Fill a container with coloured water and pour all the water into the tall glass. Then refill the *same* container and pour all the water into the short, wide glass. How can the learners work out that the two glasses contain equal volumes of water? Well, the same container held both volumes, so they must be equal!

Critical knowledge

It is important that learners understand the difference between capacity and volume. “Capacity” means how much a glass (or other container) *can hold* – it doesn’t matter whether there is something in the glass or not. “Volume” is about how much water (or other substance) *is* actually in the glass. The glass might not be full. We can say this in another way. We can say “the glass is not full to capacity”.

Notes on questions

Learners may have heard a sports commentator say: “The stadium is full to capacity.” This means the stadium is holding all the people it can hold.

Do not tell learners to compare the diameters of the glasses in question 2. Rather ask them to tell you all the differences they can see between the four glasses. Then some of the learners will notice that the diameters are different.

Answers

- (a) The glasses contain different volumes of water.
(b) The sizes of the glasses differ.

UNIT

9

CAPACITY AND VOLUME

9.1 Capacity and volume

The two glasses on the right have the same **capacity** but they contain different **volumes** of water.

If you just want to drink a little water, you do not fill your glass to the top. There is then only a small **volume** of water in your glass. But it can hold more water! You can increase or decrease the volume of water in a glass.

The volume of water that the glass *can hold* when it is filled to the brim is called the **capacity** of the glass. You cannot increase or decrease the capacity of a glass.



These four glasses all have the **same capacity**, but they contain **different volumes** of water.



- (a) Do the glasses below contain the same volume of water, or do they contain different volumes of water?
(b) Give reasons for your answer.



104

UNIT 9: CAPACITY AND VOLUME

Possible misconceptions

Some learners may believe that there is less water in each glass as one moves from left to right in the picture in question 2. This may result from the misconception that if the height of the water column is less (i.e. lower), the amount (volume) of water is also less, irrespective of the width of the glass. To help such learners overcome this misconception, you may demonstrate that when the water in a narrow glass is poured into a wide glass, the height is lower in the wider glass. Also demonstrate that when the water is poured back into the narrow glass, it reaches the same level as before.

Because the focus is strongly on liquids in developing the important distinction between volume and capacity, there is a danger that learners may develop the idea that volume relates to liquids only. To prevent this misconception, you may fill two similar glasses to the same level with water and sand respectively, and point out to learners that the volume of the sand in one glass is equal to the volume of the water in the other glass.

Answers

2. Yes, it is possible. The water in the tall, narrow glass might have the same volume as the water in the wider glass next to it. That volume of the water might be the same as the volume of water in the wide glass at the end of the row. As the glasses become wider, but their heights remain the same, their capacities increase. So, as the glasses widen, the water levels decrease and it is therefore possible that all glasses contain equal volumes of water. (Do your learners understand the word “might”? We say “might” when something is possible but we have not taken measurements to make sure.)
3. (a) Approximately 250 ml
(b) Approximately 300 ml
(c) 170 ml
(d) Approximately 30 ml to 50 ml

2. Is it possible that these four glasses contain the same volume of water? Explain your answer.



An ordinary cup or glass can hold about **250 millilitres** of liquid. 250 ml is the same as a quarter of a litre.



You can take some clay and make a cube with each edge about 1 cm long. Your cube will be approximately as big as shown here.



If you do this, you will have used about **1 millilitre** of clay for your cube.

3. (a) What is the capacity of an ordinary cup or glass?
(b) Approximately how much water is there in the glass shown above?
(c) What is the volume of juice in a tin like the one shown here, if it is only half full?
(d) Approximately how much water do you think you can hold in your mouth?



Teaching guidelines

Ideally you should have a 1 ℓ container with coloured liquid in the class, as well as some cups and 8 glasses. Let learners do questions 4 and 5, then act the questions out with the cups and glasses while you take feedback on the answers.

When taking feedback on question 4, you may draw 4 cups on the board and ask learners what fraction of a litre each cup will contain. Then, when you take feedback on question 5(b), you may ask how many of the glasses contain the same amount of liquid as one of the cups in question 4. You may also write the following number sentences on the board as a description of the situation in question 4:

$$1\ 000\ \text{ml} = 250\ \text{ml} + 250\ \text{ml} + 250\ \text{ml} + 250\ \text{ml}$$

$$1\ \ell = \frac{1}{4}\ell + \frac{1}{4}\ell + \frac{1}{4}\ell + \frac{1}{4}\ell$$

Once learners have completed question 5, you may ask them to write similar number sentences to describe the situations in questions 5(a) and (b).

Notes on questions

Question 6 provides learners with opportunities to engage with fractions. To do question 6(b) they have to divide 1 000 in 5 equal parts. The answer can be used to produce the answers for questions 6(c) and (e).

To do question 6(d), learners will need to recognise that one tenth of 1 000 is 100. You may ask learners to make and complete tables such as these as an extension to question 6:

100 ml	200 ml	300 ml	400 ml	500 ml
$\frac{1}{10}\ell$	$\frac{2}{10}\ell = \frac{1}{5}\ell$	$\frac{3}{10}\ell$	$\frac{4}{10}\ell = \frac{2}{5}\ell$	$\frac{5}{10}\ell = \frac{1}{2}\ell$
125 ml	250 ml	375 ml	625 ml	750 ml
$\frac{1}{8}\ell$	$\frac{2}{8}\ell = \frac{1}{4}\ell$			

Answers

4. 4 cups
5. (a) 10 glasses (b) 125 ml (c) 125 ml
6. (a) 2 000 ml (b) 200 ml (c) 600 ml
(d) 700 ml (e) 2 600 ml (f) 1 750 ml

4. How many ordinary cups can you fill from 1 ℓ of milk?

1 litre is 1 000 millilitres.

Instead of millilitre you can write ml.

Instead of litre you can write ℓ.



5. (a) How many small glasses, each with a capacity of 100 ml, can you fill from 1 ℓ of milk?
(b) If you share 1 ℓ of milk equally between eight glasses, what will be the volume of milk in each glass?



- (c) How many millilitres is one eighth of a litre?
6. How many millilitres are each of the following?
(a) 2 ℓ (b) one fifth of a litre
(c) 3 fifths of a litre (d) 7 tenths of a litre
(e) $2\frac{3}{5}\ell$ (f) $1\frac{3}{4}\ell$

9.2 Make a measuring jug

Teaching guidelines

You may make one measuring jug in class as a demonstration, and let learners make their own jugs at home as a project.

1.	1 ℓ	or	750 ml	or	500 ml																																																												
2.	200 ml	or	150 ml	or	100 ml																																																												
3.	<table border="1"> <tr><td>_____</td><td>1 000 ml</td></tr> <tr><td>_____</td><td>800 ml</td></tr> <tr><td>_____</td><td>600 ml</td></tr> <tr><td>_____</td><td>400 ml</td></tr> <tr><td>_____</td><td>200 ml</td></tr> </table>	_____	1 000 ml	_____	800 ml	_____	600 ml	_____	400 ml	_____	200 ml	or	<table border="1"> <tr><td>_____</td><td>750 ml</td></tr> <tr><td>_____</td><td>600 ml</td></tr> <tr><td>_____</td><td>450 ml</td></tr> <tr><td>_____</td><td>300 ml</td></tr> <tr><td>_____</td><td>150 ml</td></tr> </table>	_____	750 ml	_____	600 ml	_____	450 ml	_____	300 ml	_____	150 ml	or	<table border="1"> <tr><td>_____</td><td>500 ml</td></tr> <tr><td>_____</td><td>400 ml</td></tr> <tr><td>_____</td><td>300 ml</td></tr> <tr><td>_____</td><td>200 ml</td></tr> <tr><td>_____</td><td>100 ml</td></tr> </table>	_____	500 ml	_____	400 ml	_____	300 ml	_____	200 ml	_____	100 ml																														
_____	1 000 ml																																																																
_____	800 ml																																																																
_____	600 ml																																																																
_____	400 ml																																																																
_____	200 ml																																																																
_____	750 ml																																																																
_____	600 ml																																																																
_____	450 ml																																																																
_____	300 ml																																																																
_____	150 ml																																																																
_____	500 ml																																																																
_____	400 ml																																																																
_____	300 ml																																																																
_____	200 ml																																																																
_____	100 ml																																																																
4. and 5.	<table border="1"> <tr><td>_____</td><td>1 000 ml</td></tr> <tr><td>_____</td><td>900 ml</td></tr> <tr><td>_____</td><td>800 ml</td></tr> <tr><td>_____</td><td>700 ml</td></tr> <tr><td>_____</td><td>600 ml</td></tr> <tr><td>_____</td><td>500 ml</td></tr> <tr><td>_____</td><td>400 ml</td></tr> <tr><td>_____</td><td>300 ml</td></tr> <tr><td>_____</td><td>200 ml</td></tr> <tr><td>_____</td><td>100 ml</td></tr> </table>	_____	1 000 ml	_____	900 ml	_____	800 ml	_____	700 ml	_____	600 ml	_____	500 ml	_____	400 ml	_____	300 ml	_____	200 ml	_____	100 ml	or	<table border="1"> <tr><td>_____</td><td>750 ml</td></tr> <tr><td>_____</td><td>675 ml</td></tr> <tr><td>_____</td><td>600 ml</td></tr> <tr><td>_____</td><td>525 ml</td></tr> <tr><td>_____</td><td>450 ml</td></tr> <tr><td>_____</td><td>375 ml</td></tr> <tr><td>_____</td><td>300 ml</td></tr> <tr><td>_____</td><td>225 ml</td></tr> <tr><td>_____</td><td>150 ml</td></tr> <tr><td>_____</td><td>75 ml</td></tr> </table>	_____	750 ml	_____	675 ml	_____	600 ml	_____	525 ml	_____	450 ml	_____	375 ml	_____	300 ml	_____	225 ml	_____	150 ml	_____	75 ml	or	<table border="1"> <tr><td>_____</td><td>500 ml</td></tr> <tr><td>_____</td><td>450 ml</td></tr> <tr><td>_____</td><td>400 ml</td></tr> <tr><td>_____</td><td>350 ml</td></tr> <tr><td>_____</td><td>300 ml</td></tr> <tr><td>_____</td><td>250 ml</td></tr> <tr><td>_____</td><td>200 ml</td></tr> <tr><td>_____</td><td>150 ml</td></tr> <tr><td>_____</td><td>100 ml</td></tr> <tr><td>_____</td><td>50 ml</td></tr> </table>	_____	500 ml	_____	450 ml	_____	400 ml	_____	350 ml	_____	300 ml	_____	250 ml	_____	200 ml	_____	150 ml	_____	100 ml	_____	50 ml
_____	1 000 ml																																																																
_____	900 ml																																																																
_____	800 ml																																																																
_____	700 ml																																																																
_____	600 ml																																																																
_____	500 ml																																																																
_____	400 ml																																																																
_____	300 ml																																																																
_____	200 ml																																																																
_____	100 ml																																																																
_____	750 ml																																																																
_____	675 ml																																																																
_____	600 ml																																																																
_____	525 ml																																																																
_____	450 ml																																																																
_____	375 ml																																																																
_____	300 ml																																																																
_____	225 ml																																																																
_____	150 ml																																																																
_____	75 ml																																																																
_____	500 ml																																																																
_____	450 ml																																																																
_____	400 ml																																																																
_____	350 ml																																																																
_____	300 ml																																																																
_____	250 ml																																																																
_____	200 ml																																																																
_____	150 ml																																																																
_____	100 ml																																																																
_____	50 ml																																																																

9.2 Make a measuring jug

You can make a measuring jug from a 1 ℓ or a 750 ml or a 500 ml plastic bottle. You can do this by yourself or in a team.

To do this you need water, a bottle and five similar glasses or five similar jars (for example five jam jars).

Fill the bottle with water up to its shoulder.

Empty the bottle into the five glasses or jars so that there is the same volume of water in each of them.

Pour the contents of one glass back into the bottle, and mark the water level clearly on the bottle with a pen or a strip of paper or a scratch mark.

Pour the contents of another glass back into the bottle, and mark the water level clearly on the bottle.

Continue like this until you have poured all the water back into the bottle.

1. What is the capacity of your bottle?
2. Approximately how much water was in each of your five glasses?
3. How many millilitres does each of the marks you have made on the bottle indicate?
4. Make marks halfway between the marks you have already made on the bottle.
5. Write the number of millilitres next to each of the marks on your bottle, from smallest to biggest.

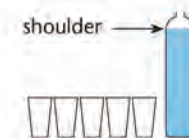

9.3 Litre and millilitre

Mathematical notes

Measuring cups such as those shown in question 3 can be used to accurately measure volumes up to 2 ℓ. Although such jugs can actually hold a bit more than 2 ℓ of liquid, their capacity is indicated as 2 ℓ.

Teaching guidelines

A model for teaching conversion of units is given on page 416 in the Addendum.

Answers

- 25 ml
Learners can work it out like this: $10 \times \text{spoon capacity} = 250 \text{ ml}$, so what number will give you 250 if you multiply it by 10? This is really a “divide by” problem; we have to divide 250 ml by 10 to get the spoon capacity.

- (a) 40 (b) 1 500 ml

Container	Capacity of container		Volume of juice	
	litres	millilitres	litres	millilitres
(a)	2	2 000	$1\frac{3}{4}$	1 750
(b)	2	2 000	$1\frac{1}{4}$	1 250
(c)	2	2 000	$1\frac{4}{5}$	1 800
(d)	2	2 000	$1\frac{1}{5}$	1 200

9.3 Litre and millilitre



- To fill a 250 ml cup with caster sugar, Rita filled a measuring spoon 10 times.
What is the capacity of the measuring spoon that Rita used?
- A certain measuring spoon has a capacity of 50 ml.
 - How many times do you have to fill the measuring spoon if you want to fill a 2 ℓ container with sugar?
 - How much sugar do you need to fill 30 measuring spoons like this one?
- In each case, state what the capacity of the container is and what the volume of juice in the container is. Give your answers in litres as well as in millilitres.

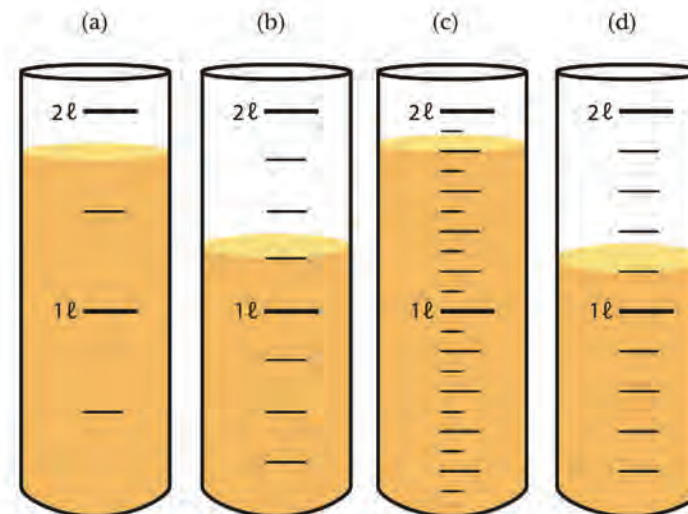

Answers

4.

	Top mark		Bottom mark	
(a)	800 ml	$\frac{4}{5} \ell$	300 ml	$\frac{3}{10} \ell$
(b)	750 ml	$\frac{3}{4} \ell$	250 ml	$\frac{1}{4} \ell$
(c)	800 ml	$\frac{4}{5} \ell$	400 ml	$\frac{2}{5} \ell$
(d)	875 ml	$\frac{7}{8} \ell$	375 ml	$\frac{3}{8} \ell$
(e)	1 600 ml	$1\frac{3}{5} \ell$	600 ml	$\frac{3}{5} \ell$
(f)	1 500 ml	$1\frac{1}{2} \ell$	500 ml	$\frac{1}{2} \ell$
(g)	1 600 ml	$1\frac{3}{5} \ell$	800 ml	$\frac{4}{5} \ell$
(h)	7 500 ml	$7\frac{1}{2} \ell$	1 250 ml	$1\frac{1}{4} \ell$

5. (a) 3 500 ml (b) 1 250 ml (c) 125 ml
 (d) 2 500 ml (e) 2 750 ml (f) 1 250 ml
 (g) 4 700 ml (h) 6 000 ml (i) 600 ml

4. Different scales are given below. For each scale, write the numbers and units (ml or ℓ) that should appear at the marks that the arrows are pointing at. Do this from top to bottom. Write your answers in millilitres as well as in fractions of a litre, for example: 50 ml; $\frac{1}{20} \ell$.

The marks and numbers on a measuring jug are called the **scale**.

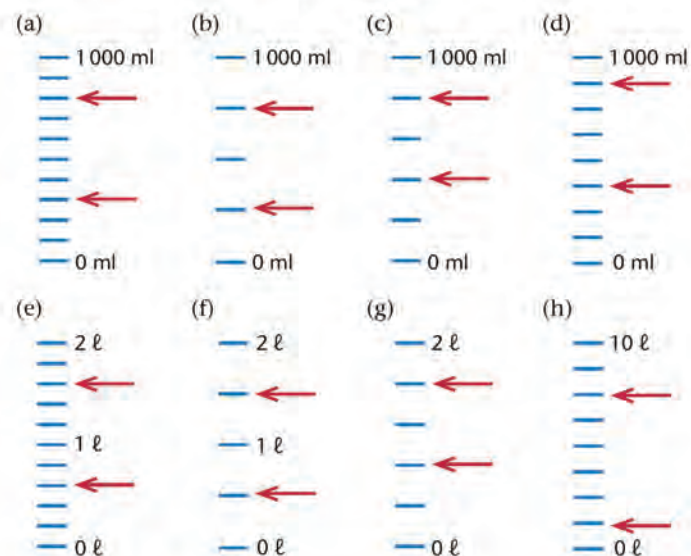

1 litre is 1 000 ml.

You can write 1 500 ml as $1 \ell + 500 \text{ ml}$ or as $1\frac{1}{2} \ell$.

Other ways to write this are $1,500 \ell$ and $1,5 \ell$. The 1 tells you that you have 1 full litre and the 0,500 or 0,5 tells you that you have another $\frac{1}{2} \ell$.

5. Express each of the following in millilitres.

- (a) $3 \ell + 500 \text{ ml}$ (b) $1 \ell + 250 \text{ ml}$ (c) $\frac{1}{8} \ell$
 (d) $2,5 \ell$ (e) $2\frac{3}{4} \ell$ (f) $1 \ell + \frac{1}{4} \ell$
 (g) $4\frac{7}{10} \ell$ (h) 6ℓ (i) $\frac{3}{5} \ell$

Answers

6. (a) $1 \ell + 50 \text{ ml}$; $1\ 250 \text{ ml}$; $1\frac{1}{2} \ell$
(b) $5 \ell + 75 \text{ ml}$; $5\frac{1}{2} \ell$; $5\ 750 \text{ ml}$
(c) $4 \ell + 34 \text{ ml}$; $4\ 734 \text{ ml}$; $4\frac{3}{4} \ell$
7. (a) $19\frac{1}{2} \ell$; $19 \ell + 250 \text{ ml}$; $9\ 250 \text{ ml}$
(b) $6\frac{1}{3} \ell$; $6 \ell + 5 \text{ ml}$; 650 ml
(c) $87 \ell + 50 \text{ ml}$; $8\ 750 \text{ ml} = 8\frac{3}{4} \ell$; $8,5 \ell$

9.4 Calculations and problem solving

Notes on questions

To help learners get started on question 1, ask them to draw a picture of an empty paper cup and mark it “250 ml”. Then ask them to colour in the cooldrink to a height that shows where 235 ml would reach, and write “235 ml” next to that height.

Answers

1. (a) She needs about $11\ 985 \text{ ml} = 11 \ell + 985 \text{ ml}$. So she should buy 12ℓ of cooldrink.
(b) 8 bottles
2. (a) 45 litres (b) 45 000 millilitres
(c) 79 crates (d) 1 422 bottles

6. Write these volumes in ascending order (from the smallest to the largest):

- (a) $1\frac{1}{2} \ell$; $1 \ell + 50 \text{ ml}$; $1\ 250 \text{ ml}$
(b) $5\ 750 \text{ ml}$; $5\frac{1}{2} \ell$; $5 \ell + 75 \text{ ml}$
(c) $4\frac{3}{4} \ell$; $4 \ell + 34 \text{ ml}$; $4\ 734 \text{ ml}$

7. Write these volumes in descending order (from the largest to the smallest):

- (a) $19 \ell + 250 \text{ ml}$; $19\frac{1}{2} \ell$; $9\ 250 \text{ ml}$
(b) 650 ml ; $6 \ell + 5 \text{ ml}$; $6\frac{1}{3} \ell$
(c) $8\ 750 \text{ ml}$; $87 \ell + 50 \text{ ml}$; $8\frac{3}{4} \ell$; $8,5 \ell$

9.4 Calculations and problem solving

1. Winnie invited 17 friends to her party. The paper cups they will use have a capacity of 250 ml, but her mom usually only pours about 235 ml into each cup, so they don't spill.
- (a) How much cooldrink should she buy if each guest will have 3 cups of cooldrink? Write your answer in millilitres and litres.
(b) Winnie's mom buys the cooldrink in $1\frac{1}{2} \ell$ bottles. How many bottles must she buy?
2. A big supermarket group sells many large crates of cooldrink every month. One crate holds eighteen $2,5 \ell$ bottles.
- (a) How many litres of cooldrink are in 18 bottles?
(b) How many millilitres of cooldrink is that?
(c) At one stage there were only 632 crates left in the warehouse. They were distributed equally to 8 stores. How many crates did each store get?
(d) How many bottles did each store get?

Answers

3. (a) R130
(b) 6 cartons of milk at R26 per carton
(6 cartons of milk at R26 per carton = R156; 9 cartons at R21 per carton = R189)
4. (a) $1\frac{1}{4}$ ℓ milk
(b) 21 scoops
(c) 75 scoops of ice cream and $6\frac{1}{4}$ ℓ milk
(d) 8 milkshakes and 24 scoops of ice cream
5. (a) R741 (b) R10,50 (c) 109 litres

3. A 2 ℓ carton of milk costs R21 at a supermarket. A shop at a filling station sells the same 2 ℓ carton of milk for R26.
- (a) Annette pays R105 for the milk that she buys at the supermarket. How much would she have paid for the same number of cartons at the shop at the filling station?
- (b) What costs less: 6 cartons of milk at R26 per carton or 9 cartons of milk at R21 per carton?
4. Each milkshake at *The Sweet Tooth* is made with 3 scoops of ice cream and $\frac{1}{4}$ ℓ milk.
- (a) How much milk is used with 15 scoops of ice cream?
- (b) How much ice cream is added to $1\frac{3}{4}$ ℓ milk?
- (c) How much ice cream and how much milk are needed for 25 milkshakes?
- (d) How many milkshakes can be made with 2 ℓ milk, and how much ice cream will be needed?
5. (a) If petrol costs R9,50 per litre, how much does 78 ℓ petrol cost?
- (b) If 9 ℓ of petrol cost R94,50, what is the price of 1 ℓ?
- (c) If petrol costs R8,00 per litre and you paid R872 to fill your tank, how many litres did you buy?

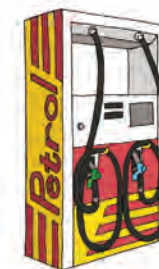

Term 2

Unit 1: Whole numbers	123
1.1 Counting and representing bigger numbers	124
1.2 Order and compare numbers	128
Unit 2: Whole numbers: Addition and subtraction	130
2.1 Facts and skills for addition and subtraction	131
2.2 Add and subtract 5-digit numbers	136
2.3 Apply your knowledge	139
Unit 3: Common fractions	140
3.1 Dividing into fraction parts	141
3.2 Work with fraction parts	144
3.3 Measure with fractions of a unit	147
3.4 Compare and order fractions	150
3.5 Count in fractions on the number line	152
3.6 Solve problems	153
Unit 4: Length	155
4.1 Know the measuring units	156
4.2 Estimate and measure	158
4.3 Converting units	162
4.4 Rounding off with units of measurement	165
4.5 Problem solving	167
Unit 5: Whole numbers: Multiplication	170
5.1 Refresh your multiplication memory	171
5.2 Working with hundreds	173
5.3 Multiply 3-digit numbers by 1-digit numbers	175
5.4 Multiply 3-digit numbers by 2-digit numbers	176
5.5 Rate	177
5.6 Ratio	179

Unit 6: Properties of three-dimensional objects	181
6.1 Flat and curved surfaces on 3-D objects	182
6.2 Make cylinders and cones	184
6.3 Make prisms and pyramids	187
Unit 7: Geometric patterns	191
7.1 Making patterns	192
7.2 From pictures to tables	193
7.3 Extending patterns	194
7.4 Using patterns to solve problems	195
Unit 8: Symmetry	197
8.1 Drawing symmetrical figures	198
8.2 Finding lines of symmetry	200
8.3 Moving figures to make symmetries	202
Unit 9: Whole numbers: Division	204
9.1 Build multiplication knowledge for division	205
9.2 Use multiplication facts to do division	207
9.3 Find answers for practical questions	209
9.4 Multiply and divide	211

Learner Book Overview		
Sections in this unit	Content	Pages in Learner Book
1.1 Counting and representing bigger numbers	Counting; representing 6-digit numbers in words, in symbols and in expanded notation, and rounding them off	115 to 119
1.2 Order and compare numbers	Counting; comparing and ordering numbers up to 6-digits	119 to 120

CAPS time allocation	1 hour
CAPS page references	13 to 15 and 156

Mathematical background

Number concept involves a variety of aspects, including the following:

- Knowing the number names and the ability to read number symbols aloud fluently by saying the number names, for example to say “three hundred and fifty-two thousand nine hundred and seventy-six” when reading 352 976.
- The ability to count, i.e. to establish the number of objects in a collection. Being able to say the number names in sequence is a prerequisite for being able to count, but does not in itself constitute the ability to count.
- Being able to write the number symbol and expanded notation for numbers.

Resources

Place value cards

1.1 Counting and representing bigger numbers

Critical knowledge

Apart from knowing how to represent numbers in different ways, learners need to have a sense of the size (magnitude) of the collections or quantities described by larger numbers.

Teaching guidelines

Learners often do not have personal experience of large quantities, hence the diagram with 10 000 stripes on page 116 of the Learner Book. Learners have engaged with this diagram before, in Term 1 Unit 1. It may, however, be useful to guide them towards analysing it by asking questions such as those given on the next page, at the start of the lesson.

Then put questions such as these to the whole class, to get them to form ideas of collections of large numbers of objects in their minds:

“Think of three pages like the next page.

How many blocks of 100 are there on the three pages together?

How many stripes are there on the three pages together?”

Show on the board how thirty thousand can be written in different ways:

thirty thousand

30 thousand

30 000

Answers

- | | | |
|-------------|-------------|-------------|
| (a) 40 000 | (b) 70 000 | (c) 120 000 |
| (d) 200 000 | (e) 260 000 | (f) 400 000 |
- | | | | | |
|-------------|---------|---------|---------|---------|
| (a) 20 000 | 30 000 | 40 000 | 50 000 | 60 000 |
| 70 000 | 80 000 | 90 000 | 100 000 | 110 000 |
| 120 000 | 130 000 | 140 000 | 150 000 | 160 000 |
| 170 000 | 180 000 | | | |
| (b) 200 000 | 210 000 | 220 000 | 230 000 | 240 000 |
| 250 000 | 260 000 | 270 000 | 280 000 | 290 000 |
| 300 000 | 310 000 | 320 000 | 330 000 | 340 000 |
| 350 000 | 360 000 | 370 000 | 380 000 | 390 000 |
| 400 000 | | | | |

UNIT

1

WHOLE NUMBERS

1.1 Counting and representing bigger numbers

Look at the next page.

There are ten thousand stripes on the next page.

Ten thousand is written like this in number symbols: 10 000

On *two* pages like the next page, there will be twenty thousand stripes altogether.

Twenty thousand is written like this in number symbols: 20 000

On *nine* pages like the next page, there will be ninety thousand stripes altogether.

Ninety thousand is written like this in number symbols: 90 000

On *ten* pages like the next page, there will be a hundred thousand stripes altogether.

Hundred thousand is written like this in number symbols: 100 000

- Write the number symbols for each of the following numbers.
 - forty thousand
 - seventy thousand
 - one hundred and twenty thousand
 - two hundred thousand
 - two hundred and sixty thousand
 - four hundred thousand
- Count and write the number symbols as you go along.
 - Count in ten thousands from 20 000 up to 180 000.
 - Count in ten thousands from 200 000 up to 400 000.

Suggested questions to start the lesson

You could put these questions to the whole class at the start of the lesson, to help learners to familiarise themselves with the diagram.

1. Estimate how many stripes there are in the whole diagram.
2. The diagram has ten rows of blocks of stripes. How many blocks are there in each row?
3. How many stripes are there in each block?
4. How many blocks are there in the whole diagram?
5. How many stripes are there in each row?
6. How many stripes are there in the whole diagram?
7. How many stripes are there in half of the diagram?
8. How many stripes are there in three rows of the diagram?

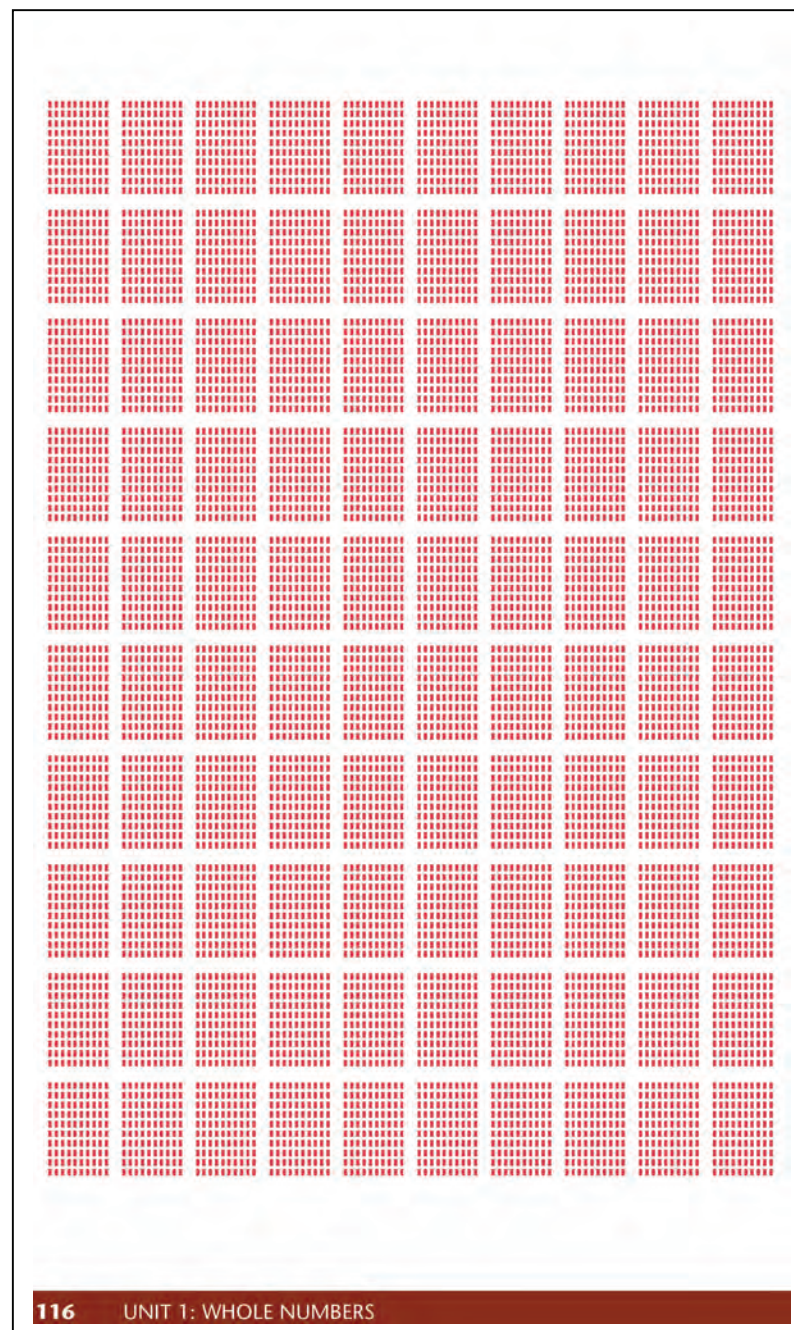

Teaching guidelines

In addition to the questions in the Learner Book, let learners “build” some larger numbers with place value cards. Monitor how they do it. It is important that they do not try to build numbers with single-digit cards only, but use the place value cards that show the place value parts of the numbers.

Possible misconceptions

Learners sometimes have the very dangerous misconception that a number is a collection of single digits. Although the number symbol is written with digits, the digits correspond to the place value parts. Working with place value cards helps to combat this misconception.

Answers

3. (a) three thousand millimetres 3 000 mm
(b) thirty thousand millimetres 30 000 mm
(c) three hundred thousand millimetres 300 000 mm
(d) two hundred and eighty thousand millimetres 280 000 mm
(e) seven hundred and twenty thousand millimetres 720 000 mm

3. One metre is 1 000 millimetres.
Write your answers to the questions in words and in symbols. This means you must write the number names and the number symbols.
- (a) How many millimetres are equal to 3 metres?
(b) How many millimetres are equal to 30 metres?
(c) How many millimetres are equal to 300 metres?
(d) How many millimetres are equal to 280 metres?
(e) How many millimetres are equal to 720 metres?

The number *five hundred and sixty-seven thousand three hundred and twenty-eight* can be broken down into the following place value parts:

500 000 60 000 7 000 300 20 8

Imagine that the place value parts are written on strips of cardboard or paper.

The strips can then be put on top of each other to show what the number symbol looks like. The zeros of the bigger place value parts are hidden in the number symbol.

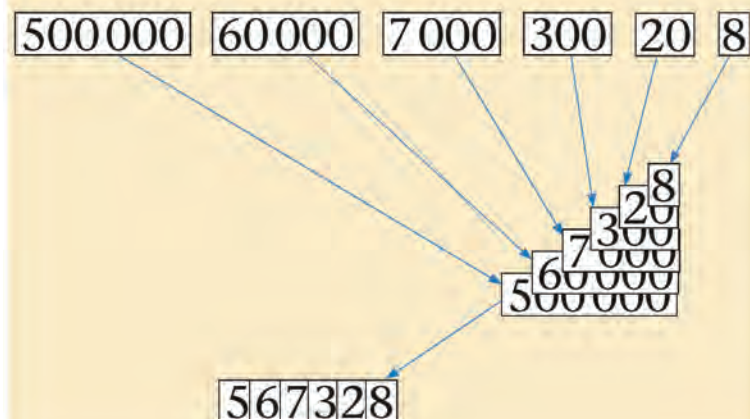

Teaching guidelines

It is very important that learners get some experience in saying the names of larger numbers aloud. Apart from questions 4 to 6, which learners do in writing, you may do a class activity like the following:

Write five 6-digit numbers on the board, for example the numbers below.

- A. 308 207
- B. 380 207
- C. 380 270
- D. 308 720
- E. 300 827

Ask learners to write down the numbers, with the labels A to E.

Let learners now work in pairs. One learner reads one of the numbers, without stating the label, and the other learner has to recognise which number is read. If the learners have a disagreement, they consult you. Learners take turns.

Answers

- | | | |
|--------|--|---------|
| 4. (a) | $200\,000 + 90\,000 + 5\,000 + 100 + 80 + 5$ | 295 185 |
| (b) | $900\,000 + 700 + 5$ | 900 705 |
| (c) | $500\,000 + 4\,000 + 30 + 8$ | 504 038 |
| (d) | $400\,000 + 20\,000 + 4\,000 + 100 + 40 + 3$ | 424 143 |
| (e) | $200\,000 + 10\,000 + 5\,000 + 600 + 80 + 2$ | 215 682 |
| (f) | $900\,000 + 80\,000 + 9\,000 + 800 + 90 + 8$ | 989 898 |
| (g) | $200\,000 + 30\,000 + 1\,000 + 700 + 10 + 1$ | 231 711 |
| (h) | $800\,000 + 50\,000 + 7\,000 + 200 + 60 + 8$ | 857 268 |

When we write 4-digit, 5-digit and 6-digit numbers, we can leave a space before the *last* group of three digits. For example, we can write:

7 622 instead of 7622

54 382 instead of 54382

136 961 instead of 136961.

This way of grouping the digits makes it easier to read and say a number.

Also notice how we use the word “and” before the tens and ones in each group of three digits when we say and write the number names of large numbers:

2 004 two thousand *and* four

2 714 two thousand seven hundred *and* fourteen

2 734 two thousand seven hundred *and* thirty-four

22 714 twenty-two thousand seven hundred *and* fourteen

272 609 two hundred *and* seventy-two thousand
six hundred *and* nine

4. Write the number symbol and expanded notation for each number.
- (a) two hundred and ninety-five thousand one hundred and eighty-five
 - (b) nine hundred thousand seven hundred and five
 - (c) five hundred and four thousand and thirty-eight
 - (d) four hundred and twenty-four thousand one hundred and forty-three
 - (e) two hundred and fifteen thousand six hundred and eighty-two
 - (f) nine hundred and eighty-nine thousand eight hundred and ninety-eight
 - (g) two hundred and thirty-one thousand seven hundred and eleven
 - (h) eight hundred and fifty-seven thousand two hundred and sixty-eight

Answers

5. (a) seven hundred and eighty-nine thousand three hundred and twenty-four
 $700\ 000 + 80\ 000 + 9\ 000 + 300 + 20 + 4$
 (b) five hundred and twenty-eight thousand seven hundred and thirty-eight
 $500\ 000 + 20\ 000 + 8\ 000 + 700 + 30 + 8$
 (c) five hundred and one thousand one hundred and three
 $500\ 000 + 1\ 000 + 100 + 3$
 (d) four hundred and forty-one thousand one hundred and sixty
 $400\ 000 + 40\ 000 + 1\ 000 + 100 + 60$
 (e) two hundred and eighty-seven thousand five hundred and sixty-four
 $200\ 000 + 80\ 000 + 7\ 000 + 500 + 60 + 4$
 (f) four hundred and eighty-seven thousand nine hundred and twenty-three
 $400\ 000 + 80\ 000 + 7\ 000 + 900 + 20 + 3$
6. (a) ten (b) hundred (c) thousand
- | | | | |
|-------------|---------|---------|---------|
| (a) 789 324 | 789 320 | 789 300 | 789 000 |
| (b) 528 738 | 528 740 | 528 700 | 529 000 |
| (c) 501 103 | 501 100 | 501 100 | 501 000 |
| (d) 441 160 | 441 160 | 441 200 | 441 000 |
| (e) 287 564 | 287 560 | 287 600 | 288 000 |
| (f) 487 923 | 487 920 | 487 900 | 488 000 |

1.2 Order and compare numbers

Teaching guidelines

You may explain “ascending” and “descending” as “upwards” and “downwards”, and draw arrows to demonstrate this.

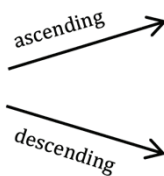

Answers

1. 40 800 41 200 41 600 42 000 42 400 42 800
 43 200 43 600 44 000 44 400 44 800 45 200

2.

9 000	11 250	13 500	15 750	18 000
20 250	22 500	24 750	27 000	29 250
31 500	33 750	36 000	38 250	40 500
42 750	45 000	47 250	49 500	51 750
54 000	56 250	58 500	60 750	63 000

3. and 4. See the next page.

5. Write the number name and expanded notation for each number.

- | | |
|-------------|-------------|
| (a) 789 324 | (b) 528 738 |
| (c) 501 103 | (d) 441 160 |
| (e) 287 564 | (f) 487 923 |

6. Round off each of the numbers in question 5 to the nearest:

- (a) ten
 (b) hundred
 (c) thousand.

1.2 Order and compare numbers

1. Count in four hundreds from 40 800 until you reach 45 200. Write down the number symbols as you go along.
2. Copy this number grid and complete it. You have to count in 2 250s to do this.

9 000	11 250	13 500	15 750	
20 250				
	33 750			40 500
42 750				
	56 250		60 750	

3. Arrange these numbers in **ascending order** (from smallest to biggest).

66 152 98 987 95 923 98 899 21 965 47 677

4. Arrange these numbers in **descending order** (from biggest to smallest).

27 180 65 153 20 122 20 121 31 999 31 001

Answers

3. 21 965 47 677 66 152 95 923 98 899 98 987
4. 65 153 31 999 31 001 27 180 20 122 20 121
5. 10 000 40 000 70 000 100 000 130 000 160 000
190 000 220 000 250 000 280 000 310 000
6. 800 000 794 000 788 000 782 000 776 000 770 000
764 000 758 000 752 000 746 000 740 000
7. 637 173 641 245 646 091 656 488
662 786 673 168 680 901
8. 999 820 996 788 953 156 945 678
941 783 928 028 927 891
9. (a) $63\,372 > 63\,002$ (b) $86\,762 > 68\,872$
(c) $27\,901 < 28\,817$ (d) $35\,530 < 53\,305$
(e) $390\,860 = 390\,860$ (f) $701\,847 < 710\,874$

5. Count in thirty thousands from 10 000 up to 310 000. Write down the number symbols as you go along.
6. Start at 800 000 and count backwards in six thousands until you reach 740 000. Write the number symbols as you go along.
7. The seven numbers below are all bigger than 600 000 but smaller than 700 000. Arrange these numbers in ascending order.

641 245 662 786 680 901 646 091
656 488 673 168 637 173

8. The seven numbers below are all bigger than 900 000 but smaller than 1 000 000. Arrange these numbers in descending order.

928 028 953 156 999 820 941 783
927 891 945 678 996 788

9. In each case, decide whether the first number is bigger than, smaller than or equal to the second number. Then write the two numbers with the $<$ or $>$ or $=$ sign between the numbers.

Examples: $63\,372 < 64\,372$; $45\,871 > 20\,200$; $17\,081 = 17\,081$

- (a) 63 372 and 63 002 (b) 86 762 and 68 872
(c) 27 901 and 28 817 (d) 35 530 and 53 305
(e) 390 860 and 390 860 (f) 701 847 and 710 874

Learner Book Overview		
Sections in this unit	Content	Pages in Learner Book
2.1 Facts and skills for addition and subtraction	Mental Mathematics	121 to 124
2.2 Add and subtract 5-digit numbers	Addition and subtraction of 5-digit numbers by breaking down into place value parts, rearranging, and building up the answer	125 to 127
2.3 Apply your knowledge	Word problems	128

CAPS time allocation	5 hours
CAPS page references	13 to 15 and 157 to 159

Mathematical background

The format below, which was introduced in Term 1 for 4-digit numbers, is used for addition and subtraction with 5-digit numbers in this unit. It provides a bridge towards adding and subtracting in columns, which is introduced in Term 3.

$$34\ 687 + 23\ 365 + 18\ 435$$

$$34\ 687 = 30\ 000 + 4\ 000 + 600 + 80 + 7$$

$$23\ 365 = 20\ 000 + 3\ 000 + 300 + 60 + 5$$

$$18\ 435 = 10\ 000 + 8\ 000 + 400 + 30 + 5$$

$$\text{Total} = 60\ 000 + 15\ 000 + 1\ 300 + 170 + 17$$

$$= 70\ 000 + 6\ 000 + 400 + 80 + 7$$

$$= 76\ 487$$

$$73\ 456 - 26\ 879$$

$$73\ 456 = 70\ 000 + 3\ 000 + 400 + 50 + 6$$

$$= 60\ 000 + 12\ 000 + 1\ 300 + 140 + 16$$

$$26\ 879 = 20\ 000 + 6\ 000 + 800 + 70 + 9$$

$$73\ 456 - 26\ 879 = 40\ 000 + 6\ 000 + 500 + 70 + 7$$

$$= 46\ 577$$

Understanding the replacements, shown in red, in the second last step of addition and the second step of subtraction is critical to understanding the “break down, rearrange and build up” methods of addition and subtraction.

2.1 Facts and skills for addition and subtraction

Teaching guidelines

This whole section (questions 1 to 15) is about Mental Mathematics.

Questions 1 to 10 are intended to develop skill in using number facts for small numbers to form number facts for bigger numbers (multiples of 10, 100 and 1 000).

Question 3(c) forces learners to think of each single bottle as 1 000 ml. Experiences like this may help to protect learners against losing awareness of place value when they start to record calculations in columns later in the year (see “Possible misconceptions” on the next page).

Answers

- Answers will differ. Possible examples are:
 - 25 to 30 ml
 - Approximately 20 mouthfuls
 - Approximately 15 000 ml
- 3 000 ml
 - 40 000 ml
- 30 bottles
 - 50 bottles
 - 80 000 ml

UNIT

2

WHOLE NUMBERS:

ADDITION AND SUBTRACTION

2.1 Facts and skills for addition and subtraction

Up to now you have added and subtracted with numbers up to 10 000. This term, you will work with bigger numbers, up to 100 000.

To do this well, you need to know facts such as $40\,000 + 30\,000 = 70\,000$ and $90\,000 - 40\,000 = 50\,000$.

- Approximately how many millilitres is a mouthful of water?
 - Approximately how many mouthfuls of water can you drink from a full 500 ml bottle?
 - Approximately how many millilitres of water do you drink in a month?
- How many millilitres are equal to 3 litres of milk?
 - How many millilitres are equal to 40 litres of milk?
- How many bottles are shown here?



- And how many bottles are shown here?



- If each bottle contains 1 000 ml of juice, how many millilitres of juice are there altogether in all the bottles in (a) and (b)?

Possible misconceptions

When learners start to record calculations in the vertical column format, they may easily lose sight of the actual meanings (place values) of the digits in the tens, hundreds, thousands and ten thousands columns. When recording their work in columns as shown below, learners may think as described in the bubbles and lose sight of the actual magnitude of the numbers. We may refer to this as **loss of awareness of place value**.

$$\begin{array}{r} 5236 \\ + 3243 \\ \hline 8479 \end{array}$$

Thought bubbles: $5 + 3 = 8$, $6 + 3 = 9$, $2 + 2 = 4$, $3 + 4 = 7$

There is nothing wrong about using knowledge of number facts for single-digit numbers to produce facts about multi-digit numbers, for example to utilise the knowledge that $5 + 3 = 8$ to claim that $5\ 000 + 3\ 000 = 8\ 000$. However, it is bad if learners become completely unaware of the fact that they are actually engaging with 5 000 and 3 000 when they just think of $5 + 3$ to produce the “8” in the answer 8 479 for the calculation shown above. They should rather have the actual numbers in mind, as shown below.

$$\begin{array}{r} 5236 \\ + 3243 \\ \hline 8479 \end{array}$$

Thought bubbles: $5\ 000 + 3\ 000 = 8\ 000$, $6 + 3 = 9$, $200 + 200 = 400$, $30 + 40 = 70$

Answers

- (a) 70 000 ml (b) 90 000 ml
- (a) 60 000 (b) 40 200
(c) 42 000 (d) 70 700
- (a) 10 lines (b) 1 000 mm (c) 5 000 mm
(d) 10 000 mm (e) 15 000 mm (f) 63 000 mm
- 1 100 mm
- (a) 50 000 mm (b) 9 000 mm (c) 59 000 mm
(d) 59 000 mm (e) 85 000 mm (f) 93 000 mm

- (a) How much is 30 thousand ml milk + 40 thousand ml milk?
(b) How much is 40 thousand ml milk + 50 thousand ml milk?
- How much is each of the following?
(a) $40\ 000 + 20\ 000$ (b) $40\ 000 + 200$
(c) $40\ 000 + 2\ 000$ (d) $20\ 300 + 50\ 400$

- This line is 100 mm long.



- How many lines like this do you have to put next to each other to get 1 m?
 - How many millimetres are there in 1 m?
 - How many millimetres are there in 5 m?
 - How many millimetres are there in 10 m?
 - How many millimetres are there in 15 m?
 - How many millimetres are there in 63 m?
- How many mm long are all these lines together?

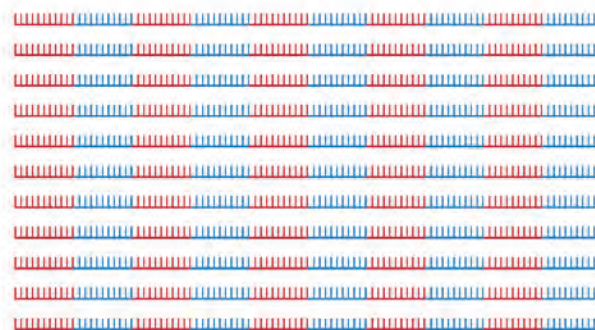

- $34\ \text{m} = 34\ 000\ \text{mm}$

How many millimetres are each of the following?

- $20\ \text{m} + 30\ \text{m}$ (b) $4\ \text{m} + 5\ \text{m}$
(c) $24\ \text{m} + 35\ \text{m}$ (d) $25\ \text{m} + 34\ \text{m}$
(e) $42\ \text{m} + 43\ \text{m}$ (f) $37\ \text{m} + 56\ \text{m}$

Mathematical notes

Filling up to the nearest multiple of ten, hundred, thousand, etc. is an important mental mathematics technique. The tinted passage indicates how thinking of the number line can support the mental application of this technique.

Answers

9. (a) 80 ℓ
(b) 50 000 ml
10. (a) 20 000
(b) 35 000
11. (a) $15\ 000 + ? \rightarrow 20\ 000 + ? = ?$
 $15\ 000 + 5\ 000 \rightarrow 20\ 000 + 3\ 000 = 23\ 000$
- (b) $57\ 000 + ? \rightarrow 60\ 000 + ? = ?$
 $57\ 000 + 3\ 000 \rightarrow 60\ 000 + 4\ 000 = 64\ 000$
- (c) $85\ 000 + ? \rightarrow 90\ 000 + ? = ?$
 $85\ 000 + 5\ 000 \rightarrow 90\ 000 + 10\ 000 = 100\ 000$
- (d) $36\ 000 + ? \rightarrow 40\ 000 + ? = ?$
 $36\ 000 + 4\ 000 \rightarrow 40\ 000 + 6\ 000 = 46\ 000$
- (e) $69\ 500 + ? \rightarrow 70\ 000 + ? = ?$
 $69\ 500 + 500 \rightarrow 70\ 000 + 300 = 70\ 300$

9. There is 80 000 ml of milk in a container.
- (a) How many litres of milk is this?
- (b) How many millilitres of milk are left in the container if 30 000 ml of milk is taken out to fill bottles?
10. Calculate each of the following.
- (a) $3\ 000 + 5\ 000 + 8\ 000 + 4\ 000$
- (b) $13\ 000 + 5\ 000 + 4\ 000 + 6\ 000 + 7\ 000$

You can have a picture like this in your mind to work out how much $35\ 000 + 8\ 000$ is:



You do not have to draw a number line when you think about it. You may describe your thinking like this:

$$35\ 000 + ? \rightarrow 40\ 000 + ? = ?$$

8 000 in total

11. Use question marks and arrows as it is done in the example above, to describe the thinking shown in each of these number line diagrams. Then solve your number sentences.

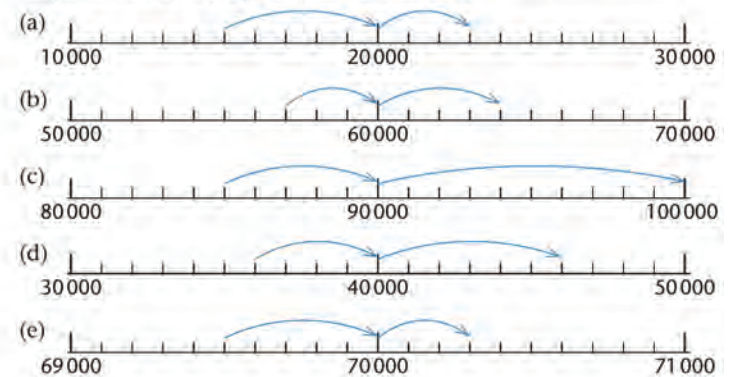

Teaching guidelines

The tinted passage describes two subtraction facts that can be formed if an addition fact is known. It serves as an example for question 12.

As an introduction to question 12, you may demonstrate that the diagram in question 11(a) on page 123 of the Learner Book represents the addition fact $15\ 000 + 8\ 000 = 23\ 000$, and ask learners whether this helps them to know what the answers for $23\ 000 - 8\ 000$ and $23\ 000 - 15\ 000$ are.

Notes on questions

Question 13 provides learners with an opportunity to test their own knowledge and skill with respect to mental mathematics as regards adding and subtracting multiples of 1 000 in the domain 1 000 to 100 000.

Explain to learners that they should identify the number sentences for which they cannot give the answers quickly, and write them down without taking time to find the answers. Once they have worked through question 13 in this way, they should do question 14.

You may let learners repeat question 13 after they have finished question 14. They may then check whether they are now able to find more of the answers immediately.

Learners should try to do question 15 with as little writing as possible, but they should write down the answers. You may let them do question 15 for a second time once they have finished and check whether they get the same answers as before. In cases where they get different answers, they should do the calculations again until a consistent answer is obtained.

Answers

12. (a) $23\ 000 - 8\ 000 = 15\ 000$ $23\ 000 - 15\ 000 = 8\ 000$
(b) $64\ 000 - 7\ 000 = 57\ 000$ $64\ 000 - 57\ 000 = 7\ 000$
(c) $100\ 000 - 15\ 000 = 85\ 000$ $100\ 000 - 85\ 000 = 15\ 000$
(d) $46\ 000 - 10\ 000 = 36\ 000$ $46\ 000 - 36\ 000 = 10\ 000$
(e) $70\ 300 - 800 = 69\ 500$ $70\ 300 - 69\ 500 = 800$
13. to 15. See the next page.

From any addition fact you can easily form two subtraction facts. For example, if you know that $60\ 000 + 20\ 000 = 80\ 000$, you also know that $80\ 000 - 20\ 000 = 60\ 000$ and $80\ 000 - 60\ 000 = 20\ 000$.

12. Use each of the number line diagrams in question 11 to form two subtraction facts.
13. Copy the number sentences for which you *cannot* find the answers quickly.

$10\ 000 + 5\ 000 = \dots$	$5\ 000 + 8\ 000 = \dots$
$5\ 000 + 9\ 000 = \dots$	$5\ 000 + 5\ 000 = \dots$
$5\ 000 + 12\ 000 = \dots$	$5\ 000 + 14\ 000 = \dots$
$19\ 000 - 7\ 000 = \dots$	$7\ 000 + 8\ 000 = \dots$
$17\ 000 + 8\ 000 = \dots$	$27\ 000 - 8\ 000 = \dots$
$57\ 000 + 8\ 000 = \dots$	$27\ 000 + 18\ 000 = \dots$
$21\ 000 + 4\ 000 = \dots$	$40\ 000 + 30\ 000 = \dots$
$4\ 000 + 39\ 000 = \dots$	$37\ 000 + 4\ 000 = \dots$
$34\ 000 + 10\ 000 = \dots$	$34\ 000 - 20\ 000 = \dots$
$31\ 000 + 9\ 000 = \dots$	$79\ 000 + 8\ 000 = \dots$
$29\ 000 + 8\ 000 = \dots$	$9\ 000 + 25\ 000 = \dots$
$27\ 000 + 18\ 000 = \dots$	$6\ 000 + 64\ 000 = \dots$

14. Use any method to complete the number sentences you wrote down in question 13.
15. Write each of the following as a single number.
- (a) $50\ 000 + 18\ 000 + 700 + 60 + 28$
(b) $40\ 000 + 4\ 000 + 1\ 300 + 80 + 7$
(c) $60\ 000 + 3\ 000 + 2\ 700 + 60 + 14$
(d) $4\ 000 + 300 + 30\ 000 + 40 + 3 + 40\ 000 + 3\ 000 + 5 + 30 + 400$
(e) $80\ 000 - 300 + 7\ 000 + 50 - 5 + 600 - 30 - 2\ 000 + 9 - 20\ 000$
(f) $30\ 000 + 4\ 000 + 200 + 30 + 2 + 50\ 000 + 3\ 000 + 500 + 30 + 6$
(g) $50\ 000 + 30\ 000 + 4\ 000 + 3\ 000 + 500 + 200 + 30 + 30 + 6 + 2$
(h) $4\ 000 + 30 + 500 + 30\ 000 + 3\ 000 + 200 + 2 + 50\ 000 + 6 + 30$

Answers (continued)

- 13.
- | | |
|-------------------------------|-------------------------------|
| $10\ 000 + 5\ 000 = 15\ 000$ | $5\ 000 + 8\ 000 = 13\ 000$ |
| $5\ 000 + 9\ 000 = 14\ 000$ | $5\ 000 + 5\ 000 = 10\ 000$ |
| $5\ 000 + 12\ 000 = 17\ 000$ | $5\ 000 + 14\ 000 = 19\ 000$ |
| $19\ 000 - 7\ 000 = 12\ 000$ | $7\ 000 + 8\ 000 = 15\ 000$ |
| $17\ 000 + 8\ 000 = 25\ 000$ | $27\ 000 - 8\ 000 = 19\ 000$ |
| $57\ 000 + 8\ 000 = 65\ 000$ | $27\ 000 + 18\ 000 = 45\ 000$ |
| $21\ 000 + 4\ 000 = 25\ 000$ | $40\ 000 + 30\ 000 = 70\ 000$ |
| $4\ 000 + 39\ 000 = 43\ 000$ | $37\ 000 + 4\ 000 = 41\ 000$ |
| $34\ 000 + 10\ 000 = 44\ 000$ | $34\ 000 - 20\ 000 = 14\ 000$ |
| $31\ 000 + 9\ 000 = 40\ 000$ | $79\ 000 + 8\ 000 = 87\ 000$ |
| $29\ 000 + 8\ 000 = 37\ 000$ | $9\ 000 + 25\ 000 = 34\ 000$ |
| $27\ 000 + 18\ 000 = 45\ 000$ | $6\ 000 + 64\ 000 = 70\ 000$ |

14. Learners do the remaining calculations from question 13.

15. (a) 68 788 (b) 45 387 (c) 65 774 (d) 77 778
(e) 65 324 (f) 87 768 (g) 87 768 (h) 87 768

From any addition fact you can easily form two subtraction facts. For example, if you know that $60\ 000 + 20\ 000 = 80\ 000$, you also know that $80\ 000 - 20\ 000 = 60\ 000$ and $80\ 000 - 60\ 000 = 20\ 000$.

12. Use each of the number line diagrams in question 11 to form two subtraction facts.
13. Copy the number sentences for which you *cannot* find the answers quickly.

- | | |
|-----------------------------|-----------------------------|
| $10\ 000 + 5\ 000 = \dots$ | $5\ 000 + 8\ 000 = \dots$ |
| $5\ 000 + 9\ 000 = \dots$ | $5\ 000 + 5\ 000 = \dots$ |
| $5\ 000 + 12\ 000 = \dots$ | $5\ 000 + 14\ 000 = \dots$ |
| $19\ 000 - 7\ 000 = \dots$ | $7\ 000 + 8\ 000 = \dots$ |
| $17\ 000 + 8\ 000 = \dots$ | $27\ 000 - 8\ 000 = \dots$ |
| $57\ 000 + 8\ 000 = \dots$ | $27\ 000 + 18\ 000 = \dots$ |
| $21\ 000 + 4\ 000 = \dots$ | $40\ 000 + 30\ 000 = \dots$ |
| $4\ 000 + 39\ 000 = \dots$ | $37\ 000 + 4\ 000 = \dots$ |
| $34\ 000 + 10\ 000 = \dots$ | $34\ 000 - 20\ 000 = \dots$ |
| $31\ 000 + 9\ 000 = \dots$ | $79\ 000 + 8\ 000 = \dots$ |
| $29\ 000 + 8\ 000 = \dots$ | $9\ 000 + 25\ 000 = \dots$ |
| $27\ 000 + 18\ 000 = \dots$ | $6\ 000 + 64\ 000 = \dots$ |

14. Use any method to complete the number sentences you wrote down in question 13.

15. Write each of the following as a single number.

- (a) $50\ 000 + 18\ 000 + 700 + 60 + 28$
(b) $40\ 000 + 4\ 000 + 1\ 300 + 80 + 7$
(c) $60\ 000 + 3\ 000 + 2\ 700 + 60 + 14$
(d) $4\ 000 + 300 + 30\ 000 + 40 + 3 + 40\ 000 + 3\ 000 + 5 + 30 + 400$
(e) $80\ 000 - 300 + 7\ 000 + 50 - 5 + 600 - 30 - 2\ 000 + 9 - 20\ 000$
(f) $30\ 000 + 4\ 000 + 200 + 30 + 2 + 50\ 000 + 3\ 000 + 500 + 30 + 6$
(g) $50\ 000 + 30\ 000 + 4\ 000 + 3\ 000 + 500 + 200 + 30 + 30 + 6 + 2$
(h) $4\ 000 + 30 + 500 + 30\ 000 + 3\ 000 + 200 + 2 + 50\ 000 + 6 + 30$

2.2 Add and subtract 5-digit numbers

Teaching guidelines

Learners have used the methods described in the tinted passages in Term 1 already (Unit 3 Section 3.7), and extension to 5-digit numbers does not present any new conceptual challenge.

Demonstrate the examples in the tinted passages on the board, or use other examples if you wish, and let learners do questions 1 to 6.

Answers

- (a) 87 015
(b) 75 925
- R74 691
- (a) $57\,592 + 53\,922 = 111\,514$
(b) $62\,412 + 49\,102 = 111\,514$
(c) $41\,038 + 70\,476 = 111\,514$
- Learners check their answers for question 3 and correct their mistakes.
- (a) $31\,440 + 4\,716 = 36\,156$
(b) $22\,611 + 13\,545 = 36\,156$
(c) $91\,633 - 55\,477 = 36\,156$
- Learners check their answers for question 5 and correct their mistakes.

2.2 Add and subtract 5-digit numbers

$34\,687 + 23\,365 + 18\,435$ can be calculated like this:

$$34\,687 = 30\,000 + 4\,000 + 600 + 80 + 7$$

$$23\,365 = 20\,000 + 3\,000 + 300 + 60 + 5$$

$$18\,435 = 10\,000 + 8\,000 + 400 + 30 + 5$$

$$\begin{aligned}\text{Total} &= 60\,000 + 15\,000 + 1\,300 + 170 + 17 \\ &= 70\,000 + 6\,000 + 400 + 80 + 7 \\ &= 76\,487\end{aligned}$$

- Calculate.
(a) $34\,362 + 52\,653$ (b) $28\,638 + 47\,287$
- Mr Marota has to pay the following amounts to the workers in his shop. What is the total amount?
R12 765 R8 392 R34 297 R19 237
- Do the calculations in brackets first, then add the answers.
(a) $(24\,764 + 32\,828) + (16\,274 + 37\,648)$
(b) $(37\,648 + 24\,764) + (32\,828 + 16\,274)$
(c) $(24\,764 + 16\,274) + (37\,648 + 32\,828)$
- If your answers for questions 3(a), (b) and (c) are not the same, you have made a mistake. If that is the case, correct your mistake.

$73\,856 - 21\,334$ can be calculated like this:

$$73\,856 = 70\,000 + 3\,000 + 800 + 50 + 6$$

$$21\,334 = 20\,000 + 1\,000 + 300 + 30 + 4$$

$$\begin{aligned}73\,856 - 21\,334 &= 50\,000 + 2\,000 + 500 + 20 + 2 \\ &= 52\,522\end{aligned}$$

- Do the calculations in brackets first, then work out the answers.
(a) $(54\,764 - 23\,324) + (36\,869 - 32\,153)$
(b) $(54\,764 - 32\,153) + (36\,869 - 23\,324)$
(c) $(54\,764 + 36\,869) - (32\,153 + 23\,324)$
- If your answers for 5(a), (b) and (c) are not the same, you have made a mistake. If that is the case, correct your mistake.

Teaching guidelines

Subtraction that requires replacement of the expanded form of the larger number is difficult work for some learners and it requires thorough teaching.

Demonstrate the examples in the tinted passage on the board. Emphasise the idea of *replacing* the expanded notation of the larger number with a breakdown into parts that will make the subtraction easy.

Answers

7. (a) $31\,000 + 3\,284 = 34\,284$
(b) $21\,895 + 12\,389 = 34\,284$
(c) $90\,917 - 56\,633 = 34\,284$

$73\,456 - 26\,879$ cannot be calculated so easily:

$$73\,456 = 70\,000 + 3\,000 + 400 + 50 + 6$$

$$26\,879 = 20\,000 + 6\,000 + 800 + 70 + 9$$

$$73\,456 - 26\,879 = 50\,000 + \text{?} + \text{?} + \text{?} + \text{?}$$

A plan needs to be made when there is not enough to subtract from, as in the above case.

One plan is to think of $73\,456$ as $70\,000 + 3\,456$ and to transfer 1 from the $70\,000$ to the $3\,456$.

In this way $73\,456$ is replaced by $69\,999 + 3\,457$.

You can then subtract $26\,879$ from $69\,999$, and add the $3\,457$ back afterwards:

$$69\,999 = 60\,000 + 9\,000 + 900 + 90 + 9$$

$$26\,879 = 20\,000 + 6\,000 + 800 + 70 + 9$$

$$\begin{aligned} 69\,999 - 26\,879 &= 40\,000 + 3\,000 + 100 + 20 + 0 \\ &= 43\,120 \end{aligned}$$

So, $73\,456 - 26\,879 = 43\,120 + 3\,457$ which is $46\,577$.

In this method you thus first change to an easier number to subtract from, then you add to the answer to compensate for the change you made.

A different plan is to replace $70\,000 + 3\,000 + 400 + 50 + 6$ by $60\,000 + 12\,000 + 1\,300 + 140 + 16$:

$$\begin{aligned} 73\,456 &= 70\,000 + 3\,000 + 400 + 50 + 6 \\ &= 60\,000 + 12\,000 + 1\,300 + 140 + 16 \end{aligned}$$

$$26\,879 = 20\,000 + 6\,000 + 800 + 70 + 9$$

$$\begin{aligned} 73\,456 - 26\,879 &= 40\,000 + 6\,000 + 500 + 70 + 7 \\ &= 46\,577 \end{aligned}$$

This is called the **transfer method** of subtraction. In the past it was called the borrowing method.

7. Do the calculations in brackets first, then add the answers.
(a) $(54\,764 - 23\,764) + (36\,153 - 32\,869)$
(b) $(54\,764 - 32\,869) + (36\,153 - 23\,764)$
(c) $(54\,764 + 36\,153) - (32\,869 + 23\,764)$

Notes on questions

Questions 10 and 12 serve a twofold purpose:

- practice in addition and subtraction
- developing awareness of properties of operations.

Once learners have completed question 10, you may tell them that they should have obtained the same answers for (a), (c) and (d). Those who have not should do the calculations again. The answer for (b) is different. The four calculation plans demonstrate that additions can be performed in any order, and that subtraction is not commutative.

In question 12 all three calculation plans have the same answer.

Answers

8. Learners check their answers for question 7 and correct their mistakes.
9. (a) 30 592 (b) 94 146 (c) 71 703 (d) 52 821
(e) 111 110 (f) 122 211 (g) 106 062 (h) 104 949
(i) 32 045 (j) 18 072 (k) 25 783 (l) 26 937
10. Learners write down which calculations they expect will have the same answer. (In fact, (a), (c) and (d) have the same answer.)
11. (a) 59 476 (b) 39 880 (c) 59 476 (d) 59 476
12. Learners write down which calculations they expect will have the same answer. (In fact, they all have the same answer.)
13. (a) 28 493 (b) 28 493 (c) 28 493
14. (a) 14 717 (b) 38 891 (c) 121 671
(d) 50 000 (e) 52 966

8. If your answers for 7(a), (b) and (c) are not the same, you have made a mistake. If that is the case, correct your mistake.
9. Calculate:
- | | |
|-------------------------|-------------------------|
| (a) $89\,324 - 58\,732$ | (b) $50\,130 + 44\,016$ |
| (c) $91\,265 - 19\,562$ | (d) $23\,481 + 29\,340$ |
| (e) $98\,765 + 12\,345$ | (f) $54\,321 + 67\,890$ |
| (g) $75\,849 + 30\,213$ | (h) $65\,748 + 39\,201$ |
| (i) $60\,073 - 28\,028$ | (j) $30\,314 - 12\,242$ |
| (k) $62\,891 - 37\,108$ | (l) $59\,832 - 32\,895$ |
10. You will do the following calculations later. You will do the calculations from left to right. Which of these do you *expect* to have the same answers?
- (a) $49\,678 + 33\,547 - 23\,749$
(b) $49\,678 - 33\,547 + 23\,749$
(c) $49\,678 - 23\,749 + 33\,547$
(d) $33\,547 - 23\,749 + 49\,678$
11. Do the calculations in question 10.
12. You will do the following calculations later. You will do the calculations from left to right. Which of these do you *expect* to have the same answers?
- (a) $69\,346 + 23\,458 - 45\,735 - 18\,576$
(b) $69\,346 - 45\,735 + 23\,458 - 18\,576$
(c) $69\,346 - 18\,576 + 23\,458 - 45\,735$
13. Do the calculations in question 12.
14. (a) What is the difference between 37 526 and 22 809?
(b) Work out the sum of 36 127, 1 786 and 978.
(c) What number is 43 606 more than 78 065?
(d) Add 37 349 to 53 782 and subtract 41 131 from the answer.
(e) What number must be added to 35 409 to make 88 375?

2.3 Apply your knowledge

Teaching guidelines

When engaging with word problems, it is critical that learners read the question carefully and try to imagine the described situation in their minds, before they decide on an operation. A good way to nudge learners towards reading and interpreting the given problem is to encourage them to produce an estimated answer first, before they start doing accurate calculations or even decide on what calculations they will do.

Learners' efforts should be directed at understanding and solving the stated problem, not at trying to identify the correct operation as quickly as possible and applying a recipe to execute it.

Answers

- (a) R40 000
(b) R42 485
- 7 246 m
- 61 182 houses
- R32 877
- 46 936 voters
- 10 777 people
- 1 769 lone bulls
- R68 184

2.3 Apply your knowledge

- Mr van Staden has to pay these bills for his furniture shop:

Electricity	R7 469
Rental	R14 298
Security services	R12 356
Insurance	R8 362

 - Approximately how much is this in total, to the nearest R10 000?
 - Calculate the exact total.
- A road athlete has already run 12 754 m of a 20 000 m race. How far does he still have to run?
- 10 476 new houses were built by a municipality during the year. Now there are 71 658 houses. How many houses were there at the beginning of the year?
- A church congregation has already spent R21 559 of its budget of R54 436. How much money is still available?
- 43 452 of the 90 388 voters in a district are male. How many of the voters are female?
- If 21 358 people live in Hari City and 32 135 people live in Ra Rangi, how many more people live in Ra Rangi than in Hari City?
- In 2005, The Kruger Park's elephant population was found to be 12 467. There were 10 698 elephants in herds and the others were lone bulls. How many lone bulls were there?
- Mr Cotton earns R57 912 per year and Mr Rice earns R10 272 more per year. Work out how much Mr Rice earns per year.

Learner Book Overview		
Sections in this unit	Content	Pages in Learner Book
3.1 Dividing into fraction parts	Revision of the naming of fractions	129 to 131
3.2 Work with fraction parts	The concept of equivalent fractions	132 to 134
3.3 Measure with fractions of a unit	Consolidation of equivalent fractions	135 to 137
3.4 Compare and order fractions	Further consolidation of equivalent fractions	138 to 139
3.5 Count in fractions on the number line	Fractions as numbers “between whole numbers”	140 to 141
3.6 Solve problems	Application of fraction knowledge and skills	141 to 142

CAPS time allocation	5 hours
CAPS page references	16 and 160 to 162

Mathematical background

It is widely assumed that fractions were invented to aid accurate measurement in cases where the commonly used standard unit of measurement could not provide an exact description of a quantity. This is reflected in the Latin names of some of our current units of measurement, for example *centimetres* (hundredths of a metre) and *millimetres* (thousandths of a metre).

If the brown strip below is measured with the yellow strip as a unit, its length is 3 and 3 fifths of the yellow unit.

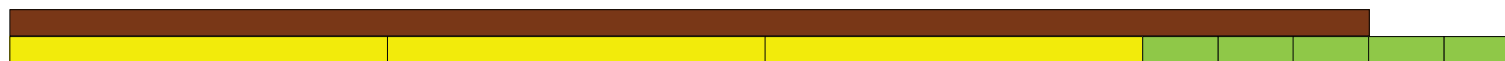

This example shows how **fractions are used as measures**.

Mathematically, the fraction concept is very important to the understanding of decimals, because the place value parts after the decimal comma are fractions. For example, the expanded notation for the number 23,47 is $20 + 3 + \frac{4}{10} + \frac{7}{100}$ or tens + 3 units + 4 tenths + 7 hundredths.

Fractions are also used to describe **parts of collections** and **parts of non-physical quantities**, for example “3 eighths of the learners in a school” or “63 hundredths of the available marks”. In a case like the latter, the percentage notation (% for hundredths) is commonly used, namely 63%.

In everyday life and language certain fractions, such as “half” and “quarter”, are sometimes used to indicate approximate **parts of whole objects**. People may, for example, refer to “a quarter of an apple” or “half a loaf of bread”. Although this everyday use of fraction language differs from the mathematical use in the sense that the fraction words are not used to indicate *precise* parts, the everyday use provides a starting point for learning about fractions.

A fraction is a number of exactly equal parts of the same object or measurement unit, for example 7 eighths of a cake or 7 hundredths of a metre.

3.1 Dividing into fraction parts

Critical knowledge

It is terribly important that learners use appropriate, correct language for fractions. They should say and sometimes also write the names of fractions **in words**. Describing a fraction as “one number over another number”, for example $\frac{3}{5}$ as “3 over 5”, should be strongly discouraged. Fractions are not about two whole numbers. This language usage undermines understanding of a fraction as **a number of parts of a given size**. The correct name for $\frac{3}{5}$ is “3 fifths”. You should consistently encourage learners to say the fraction names: “fifths”, “sixths”, “tenths”, etc.

It is for this reason that we have chosen to write the names of fractions and fraction parts without a hyphen between the numerator and the denominator (e.g. “two thirds” instead of “two-thirds”). It is also why we often use number symbols instead of the number names as numerators (e.g. “3 twenty-fifths” or “2 thirds”). You should, however, not penalise learners who choose to spell fraction names with hyphens; that is, if they write “one-third”, “two-fifths”, “three-eighths”, etc. It is grammatically correct to do so.

Teaching guidelines

Discuss the issue of fraction parts of loaves of bread being only approximate. The artist (and a bread cutting machine) cannot give us perfectly equal parts of a loaf.

Possible misconceptions

Fraction language is sometimes used in everyday life to refer to approximate parts. For example, when people refer to a quarter of an apple it is seldom exactly a quarter and, in any case, apples differ in shape and size. While the everyday use of fraction language is useful as a starting point for developing knowledge of fractions, it may weaken the understanding of the **mathematical meaning of fractions as exact fractional parts** of wholes, collections, quantities and units of measurement.

For example, in the circle alongside, each part is *not equal* to a third of the circle because the three parts are not the same size.

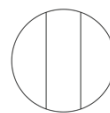

The above also applies to the context of bread used in the Learner Book; hence the pictures of parts of loaves are accompanied by fraction strips, which show exact partitions of a whole. You can point this out to the class.

Answers

1. (a) one tenth; $\frac{1}{10}$ (b) one quarter / one fourth; $\frac{1}{4}$



UNIT
3
COMMON FRACTIONS

3.1 Dividing into fraction parts

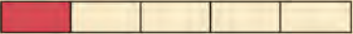
This loaf is cut into five equal parts.
Each part is **one fifth** of the loaf.
We can write one fifth in fraction notation as $\frac{1}{5}$.





This loaf is cut into twelve equal parts.
Each part is **one twelfth** of the loaf.
We can write one twelfth as $\frac{1}{12}$.



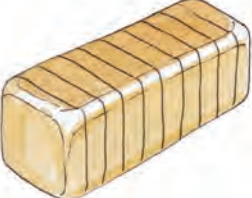

1. These loaves are cut in different ways.

(a) What do we call each part of the loaf, and how do we write this in fraction notation?

(b) What do we call each part of this loaf, and how do we write this in fraction notation?

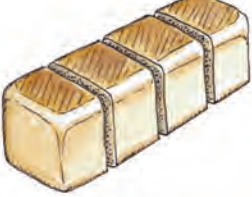
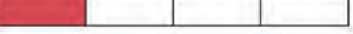
 GRADE 5: MATHEMATICS [TERM 2] 129

Critical knowledge and skills

Learners must be able to represent fractions diagrammatically by drawing fraction strips, as shown at the top of page 130 of the Learner Book. Note that these are *not* drawn with a ruler. Learners should be able to make such drawings quickly, drawing freehand so that it does not take up too much time. This will provide them with a tool to help them think what fractions really mean when working on tasks involving fractions. It is extremely important though, that learners do not spend much time on drawing fraction strips accurately. Such strips are usually not used for measuring. They are only there to support learners' conceptual thinking about fractions.

When drawing fraction strips, it is best if learners initially draw the whole strip, so that they can physically experience the partitioning of the whole strip into equal parts afterwards. This physical experience of partitioning can support their understanding of fractions as the numbers that describe the size of *parts* of wholes.

Drawing a fraction strip: When drawing a fraction strip for an even number of parts it helps to first draw the line that separates the whole strip into two halves. For quarters, eighths, sixteenths, etc., one can then continue to halve the sections, as shown below on the left. For a number of parts that is an uneven number and multiple of three (e.g. 9, 15, etc.), the first step could be to draw two lines to divide the whole strip approximately into thirds, as shown below in the middle. Drawing a fifths strip is slightly more difficult. It helps to draw a line that divides the whole strip into two parts, with the one part about one-and-a-half times as long as the other, as shown below on the right. You can quickly demonstrate this on the board:

To draw quarters:





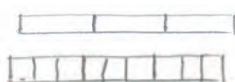

To draw ninths:

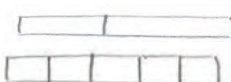

To draw fifths:



Answers

2. (a) 
 (b) 
 (c) 
 (d) 

one eighth; $\frac{1}{8}$

one seventh; $\frac{1}{7}$

one ninth; $\frac{1}{9}$

one eleventh; $\frac{1}{11}$

3. (a) six tenths; $\frac{6}{10}$



(b) three tenths; $\frac{3}{10}$

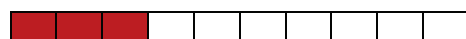

Diagrams like these are called **fraction strips**.

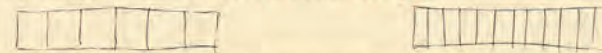

The strip on the left shows what we mean by sixths.

The strip on the right shows what we mean by twelfths.

2. In each case below, draw a fraction strip. Write down what we call each part, and also write this in fraction notation.
- A loaf of bread, or some other object, is cut into eight equal pieces.
 - An object is cut into seven equal pieces.
 - An object is cut into nine equal pieces.
 - An object is cut into eleven equal pieces.

This loaf of bread is cut into ten equal slices.

The picture below shows 7 tenths of the loaf.

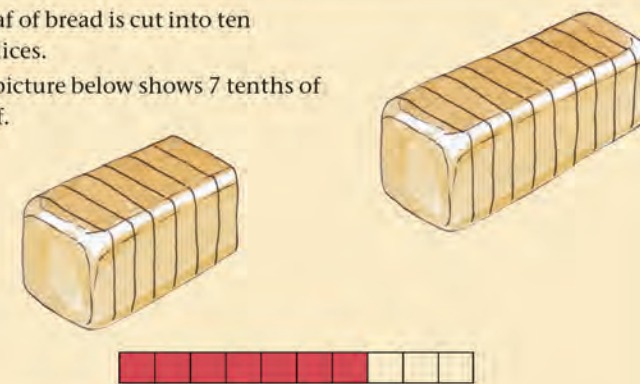

We can write 7 tenths as $\frac{7}{10}$.

3. What part of the loaf of bread above is shown in each of the pictures below? Give your answer in words and in fraction notation, and also draw a rough fraction strip in each case.

(a)



(b)



Notes on questions

When a whole is divided into equal parts, there are three quantities involved:

- the number of parts
- the size of each part
- the size of the whole.

In questions 4, 5 and 6 the size of the whole and the number of parts are given. Learners have to state the size of each part. These are **sharing** situations.

Note that question 6(b) is a bit tricky: 3 loaves of bread (not one) are shared between 12 people, so each person gets one quarter of the three loaves. The question is really about what part of *one loaf* each person gets. It is one quarter.

Question 7 is quite different. In each case the size of the whole and the size of each part are given, and learners have to determine the number of equal parts. These are **grouping** situations. The number of equal parts is the same as the number of children or people.

Answers

4. (a) 15; one fifteenth
(b) 18; one eighteenth
(c) 24; one twenty-fourth
5. (a) one twenty-fifth / $\frac{1}{25}$
(b) one fourteenth / $\frac{1}{14}$
(c) one seventh / $\frac{1}{7}$
6. (a) one fifth / $\frac{1}{5}$
(b) one quarter / $\frac{1}{4}$
7. (a) 8 children
(b) 15 people

This loaf of bread is cut into 20 equal slices.

Each slice is **one twentieth** of the loaf.

The symbol for one twentieth is $\frac{1}{20}$.



4. Into how many slices are each of these loaves of bread cut? Write down what part of the whole loaf each slice is.

(a)

(b)

(c)

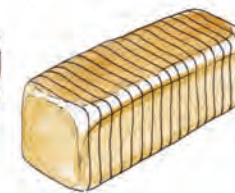

5. (a) What part of the whole loaf is each slice, if a loaf is cut into 25 equal slices?
(b) What part of the whole loaf is each slice, if a loaf is cut into 14 equal slices?
(c) What part of a cake is each slice, if the cake is cut into 7 equal slices?
6. (a) A litre of milk is shared equally between 5 children. What part of a litre does each child get?
(b) 3 loaves of bread are shared equally between 12 people. What part of a loaf does each person get?
7. (a) A cake is shared equally between all the children at a birthday party. Each child gets one eighth of the cake. How many children are at the party?
(b) 3 litres of milk were shared equally between a number of people. Each person got one fifth of a litre. How many people shared the milk?

3.2 Work with fraction parts

Teaching guidelines

Questions 5, 6 and 7 on page 134 provide learners with opportunities to refresh and consolidate their understanding of equivalent fractions. At least one full lesson period, and preferably two, is required for questions 5, 6 and 7.

Question 1 is very suitable to practise understanding of fractions. *Instruct learners to write their answers in words as well as in fraction notation.* Whether this is done at home or in class, it is a good idea to ask learners to do the work on loose sheets of paper and hand them in. Analyse the correctness of learners' responses carefully to obtain an assessment of learners' current state of knowledge of fractions. This is **formative assessment** and will guide your teaching.

Once learners have handed in their answer sheets for question 1, you may divide the class into smaller groups. Ask them to do the questions again and to compare their answers. This will provide learners with opportunities to talk about fractions and to say the names of fractions aloud. Doing this exercise may really strengthen their understanding of fractions.

However, it is important that you encourage them to say the proper fraction names, for example "seven tenths", and not the meaningless and unsound "seven over ten". Fractions are not made of whole numbers written one over the other. This can lead to a **misconception** of fractions, and later to mistakes such as adding the numerators and adding the denominators when adding fractions. We are trying to avoid leading learners into this trap.

Answers

- | | |
|---------------------------------------|-------------------------------------|
| (a) three sevenths / $\frac{3}{7}$ | (b) three tenths / $\frac{3}{10}$ |
| (c) six tenths / $\frac{6}{10}$ | (d) three fifths / $\frac{3}{5}$ |
| (e) three quarters / $\frac{3}{4}$ | (f) six eighths / $\frac{6}{8}$ |
| (g) eight twentieths / $\frac{8}{20}$ | (h) four tenths / $\frac{4}{10}$ |
| (i) two fifths / $\frac{2}{5}$ | (j) six fifteenths / $\frac{6}{15}$ |

3.2 Work with fraction parts

Part of this strip is coloured.

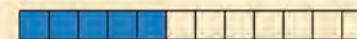

We say: **5 twelfths** of the strip is coloured.

We write: $\frac{5}{12}$ of the strip is coloured.

This strip is divided into nine equal parts. Five of the parts are coloured.

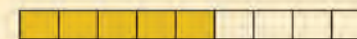

We say: **5 ninths** of the strip is coloured.

We write: $\frac{5}{9}$ of the strip is coloured.

1. What part of each strip is coloured?



Possible misconceptions

As was pointed out on the previous page, learners sometimes think that fractions consist of whole numbers written one over the other. This is quite wrong. The number below the line tells us how many parts there are in the whole and the number above the line tells us how many of these parts we have. If learners get that right in Grade 5, it will have a positive effect in other parts of the curriculum, and also in later grades.

Notes on questions

The tinted passage and questions 2 and 3 serve as a gentle introduction to adding fractions. You may ask learners to read the tinted passage and share what they understand with classmates in small groups, and then proceed to do questions 2 and 3. Note that learners who give $\frac{5}{5}$ of a loaf as an answer to 3(b) should be made aware that this is also equal to 1 whole loaf of bread.

Question 4 is different to the other questions. It is not difficult, but it may enrich the way learners conceptualise fractions.

Answers

2. (a) $\frac{5}{10} + \frac{3}{10} = \frac{8}{10}$ of a loaf
(b) $\frac{2}{10} + \frac{4}{10} = \frac{6}{10}$ of a loaf
3. (a) $\frac{3}{8}$ of a loaf + $\frac{2}{8}$ of a loaf = $\frac{5}{8}$ of a loaf
(b) $\frac{2}{5}$ of a loaf + $\frac{3}{5}$ of a loaf = 1 whole loaf
4. (a) 4 loaves
(b) 10 loaves
(c) 2 loaves

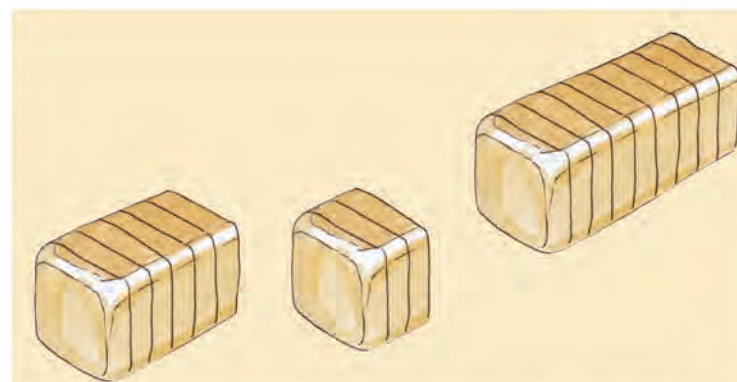

6 tenths of a loaf and 3 tenths of a loaf together is 9 tenths of a loaf.

We can write $\frac{6}{10} + \frac{3}{10} = \frac{9}{10}$

2. Write your answers as number sentences and use fraction notation as in the example above.
 - (a) If you put $\frac{5}{10}$ and $\frac{3}{10}$ of a loaf together, what part of a whole loaf do you get?
 - (b) If you put $\frac{2}{10}$ and $\frac{4}{10}$ of a loaf together, what part of a whole loaf do you get?
3. How much bread is this?
 - (a) $\frac{3}{8}$ of a loaf + $\frac{2}{8}$ of a loaf
 - (b) $\frac{2}{5}$ of a loaf + $\frac{3}{5}$ of a loaf
4. (a) 20 people must each get one fifth of a loaf. How many loaves do you need, to provide this?
 - (b) How many loaves do you need to provide 50 people with one fifth of a loaf each?
 - (c) How many loaves do you need to provide 20 people with one tenth of a loaf each?

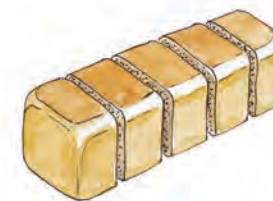

Notes on questions

Questions 5, 6 and 7 are intended to consolidate learners' awareness of equivalent fractions.

Question 7 is designed to provide you with an opportunity to bring some closure to the development of the idea of equivalent fractions in learners' minds. There are clearly three good answers for question 7(a):

- 4 twentieths
- 1 fifth
- 1 fifth, which is the same as 4 twentieths.

(The third answer may be phrased in different ways.)

Ask some learners to state their answers in class. After one answer you may ask whether someone has a different answer. Write the given answers on the board. You may take a "vote" on the three answers and write the results of the vote on the board. Do not make any judgement on the relative merit of the three answers, because that may result in learners terminating their own reflections. Reflections strengthen their understanding of equivalent fractions.

Some learners may change their minds once they have seen all three answers, as a result of reflecting on the situation and the given answers. Allow a second round of voting to provide a vehicle for learners to express their realisation that 1 fifth of a loaf is the same amount of bread as 4 twentieths of a loaf.

Question 7(b) provides for assessment of learners' concept of equivalent fractions at this stage.

Answers

5. (a) 2 eighths / $\frac{2}{8}$ (b) 4 eighths / $\frac{4}{8}$ (c) 6 eighths / $\frac{6}{8}$
6. (a) 1 twentieth / $\frac{1}{20}$ (b) 5 slices (c) 5 twentieths / $\frac{5}{20}$
- (d) 10 twentieths / $\frac{10}{20}$ (e) 15 twentieths / $\frac{15}{20}$
7. (a) one fifth / $\frac{1}{5}$ (b) $\frac{1}{5}$ and $\frac{4}{20}$ of the loaf are exactly the same.

5. (a) How many eighths of a loaf is the same as one quarter of a loaf?
- (b) How many eighths of a loaf is the same as half of a loaf?
- (c) How many eighths of a loaf is the same as $\frac{3}{4}$ of a loaf?



6. This loaf is cut into 20 slices.

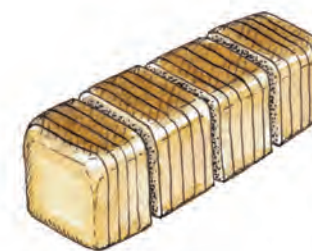
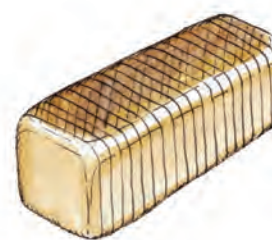

- (a) What fraction of the loaf is each slice?
- (b) The picture on the right shows the loaf divided into quarters. How many slices are there in each quarter?
- (c) How many twentieths make up each quarter?
- (d) How many twentieths are half of the loaf?
- (e) How many twentieths are equal to $\frac{3}{4}$ of the loaf?

7. The picture on the right shows a loaf of 20 slices, divided into 5 equal portions.

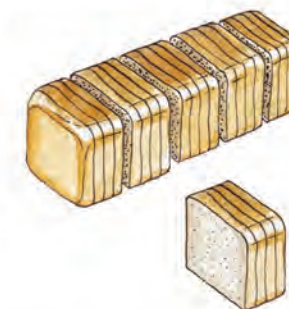

- (a) What part of the whole loaf is each portion?
- (b) Is each portion $\frac{1}{5}$ of the loaf, or is it $\frac{4}{20}$ of the loaf?

3.3 Measure with fractions of a unit

Mathematical notes

Understanding fractions as parts of units of measurement is profoundly important. It provides the conceptual basis for learners' understanding of decimal fractions, which is addressed in Grade 6. The use of fractional units of measurement also provides an empowering context for understanding equivalent fractions, in the sense that the same length (or other quantity) can be expressed in different ways in terms of fractional parts of measurement units. As mentioned before, fractions were probably invented to aid accurate measurement in cases where the commonly used standard unit of measurement could not provide an exact description of a quantity.

Answers

1. (a) one fifth (b) one sixth

Mathematical notes

Learners easily come to understand fractions as *physical objects* (or names for physical objects), which is wrong. A fraction is a number that can be used to describe the size of an object in terms of a formal or informal measurement unit, which may be another object.

For example, in the statement “Mary eats three eighths of a loaf of bread”, a whole loaf of bread serves as the **unit of measurement**. The statement is very similar to “Mary eats three eighths of a kilogram of porridge”, in which an “official” unit of measurement, the kilogram, is used. In the statement “Mary eats three eighths of a cake that Paul baked”, the specific cake that Paul baked serves as the unit of measurement. It is an informal unit.

A fraction can also be used to compare two quantities by expressing the one quantity as a fraction of the other quantity. For example, to compare the numbers 12 and 18 one may describe 12 as two thirds of 18. Clearly this is not a physical object, it is a **relationship**.

Two quantities can also be compared by stating how many repetitions of the one quantity are equal to a specified number of repetitions of the other quantity. For example, 3 ℓ of oil may have the same mass as 2 ℓ of water. This fact may also be expressed by using a fraction, namely by saying that the density of oil is 2 thirds the density of water. The fraction 2 thirds is here used to express the ratio 2 : 3. Density is an abstract quality.

3.3 Measure with fractions of a unit

Janice uses this measuring stick to measure the length of strips of metal and lace. She calls it her Brownstick.



This blue strip is exactly 2 Brownsticks long:

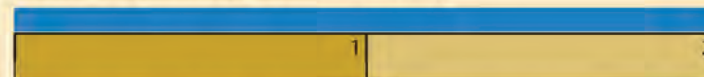

The red strip below is longer than 1 Brownstick, but it is shorter than 2 Brownsticks.



We need smaller units to measure the red strip accurately.

1. Part of this Brownstick ruler is divided into smaller units.



- (a) What part of a Brownstick is each of these smaller units?
(b) What part of a Brownstick is each of the smaller units on the ruler below?

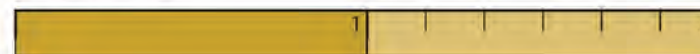

On the diagram below you can see that the red strip is **one and two fifths** of a Brownstick long, or $1\frac{2}{5}$ Brownsticks.



The ruler with sixths is not useful to measure the red strip.

Mathematical notes

It is useful to distinguish three phases in the development of the concept of equivalent fractions in learners' minds:

- Awareness that the same part of a whole (collection, quantity, unit of measurement) can be described with different fractions (see Ruler A and Ruler B in question 4).
- The ability to specify equivalent fractions by looking at diagrams such as fraction strips.
- Producing equivalent fractions with a formula – **this is not done at all in the Intermediate Phase because premature learning of the formula before the concept is strongly formed may inhibit understanding of what equivalent fractions are.** So, no formulas are to be taught. The learners are to form their own concepts.

Notes on questions

Questions 4 and 5 provide a lead into the concept of equivalent fractions.

Teaching guidelines

Discuss the fact in class that the same length can be described in different ways, especially with reference to question 5. They already know what Ruler A and Ruler B are called.

Answers

2. one and six tenths of a Brownstick long; $1\frac{6}{10}$ Brownsticks
3. one and two sixths of a Brownstick long; $1\frac{2}{6}$ Brownsticks
4. Ruler A: one and six tenths of a Brownstick long; $1\frac{6}{10}$ Brownsticks
Ruler B: one and three fifths of a Brownstick long; $1\frac{3}{5}$ Brownsticks
5. (a) Ruler C is a twentieths-ruler.
(b) 12 twentieths; $\frac{12}{20}$
(c) 12 twentieths; $\frac{12}{20}$

Write your answers to questions 2 to 7 in words and in symbols. In some of the questions you may be able to state the length in two different ways.

2. How long is this red strip?



3. How long is this blue strip?



4. How long is this yellow strip?



Ruler A above is called a **tenths-ruler** because it is marked in tenths of a Brownstick.

Ruler B is called a **fifths-ruler** because it is marked in fifths of a Brownstick.

5. (a) What can we call Ruler C below?

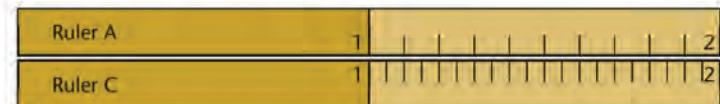

(b) How many twentieths of a Brownstick is the same length as 6 tenths of a Brownstick?

(c) How many twentieths of a Brownstick is the same length as 3 fifths of a Brownstick?

Critical knowledge

It is critical that learners understand that equivalent fractions are different, but they represent the same quantities.

Equivalent fractions are different ways to represent the same quantity, or the same part of a whole or a collection.

Answers

6. Ruler D: one and nine twelfths of a Brownstick long; $1\frac{9}{12}$ Brownsticks
Ruler E: one and six eighths of a Brownstick long; $1\frac{6}{8}$ Brownsticks
7. Ruler F: one and three quarters of a Brownstick long; $1\frac{3}{4}$ Brownsticks
Ruler C: one and fifteen twentieths of a Brownstick long; $1\frac{15}{20}$ Brownsticks

Teaching guidelines

Go through the definition of equivalent fractions, and the meaning of “equi-”. Read the tinted sentence, but *do not* attempt to explain the mathematics. The class has just experienced the truth of the statement in questions 6 and 7, and that is sufficient (until Grade 7).

8. (a) $\frac{1}{4}$ ℓ milk $>$ $\frac{1}{5}$ ℓ milk (b) $\frac{1}{4}$ ℓ milk $=$ $\frac{2}{8}$ ℓ milk
(c) $\frac{3}{10}$ ℓ milk $<$ $\frac{3}{8}$ ℓ milk (d) $\frac{4}{5}$ ℓ milk $=$ $\frac{8}{10}$ ℓ milk
9. (a) 250 ml $>$ 200 ml (b) 250 ml $=$ 250 ml
(c) 300 ml $<$ 375 ml (d) 800 ml $=$ 800 ml

6. How long is this red strip?

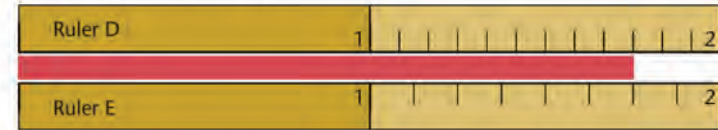

7. This is the same red strip as in question 6. How long is it?



$\frac{3}{4}$ of a Brownstick, $\frac{9}{12}$ of a Brownstick, $\frac{6}{8}$ of a Brownstick and $\frac{15}{20}$ of a Brownstick are different ways of describing the same length.

$\frac{3}{4}$ of a metre, $\frac{9}{12}$ of a metre, $\frac{6}{8}$ of a metre and $\frac{15}{20}$ of a metre are also different ways of describing the same length.

Fractions that describe the same length or quantity are called **equivalent fractions**.

“Equi-” means equal. **Equivalent** means equal value.

We can use the equal sign to indicate that fractions are equivalent.

For example, we can write $\frac{3}{4} = \frac{9}{12} = \frac{6}{8} = \frac{15}{20}$.

8. Which is more milk, or are the two volumes the same? (In some cases it may help you to look at Rulers A to F in questions 4 to 7.) Write your answers using the $>$, $<$ and $=$ signs.
- (a) $\frac{1}{4}$ ℓ milk or $\frac{1}{5}$ ℓ milk (b) $\frac{1}{4}$ ℓ milk or $\frac{2}{8}$ ℓ milk
(c) $\frac{3}{10}$ ℓ milk or $\frac{3}{8}$ ℓ milk (d) $\frac{4}{5}$ ℓ milk or $\frac{8}{10}$ ℓ milk
9. Express each of the volumes in question 8 in millilitres and then check your answers for question 8.

3.4 Compare and order fractions

Mathematical notes

A “fraction wall” is a collection of fraction strips placed directly one below the other. It is not a mathematical idea, just a teaching/learning aid.

Teaching guidelines

Learners do not need to use the given diagrams; they can also draw their own fraction strips for each question.

Notes on questions

In question 1, the same mass is expressed as different but equivalent fractions.

Question 2 provides a way to focus on the fact that a bigger number as denominator means a smaller fraction. A big number as denominator means that the whole is divided into many and hence very small parts.

The fractions in question 3 are what remains of wholes if the fractions in question 2 are removed.

Questions 2 and 3 relate to the fraction wall.

Questions 4(a) and (b) do not require any calculation. However, it is necessary to compute the answer for (c) because the real values are needed to be able to answer the question. The fractions aren't easily relatable. The answer is 250 ml for both.

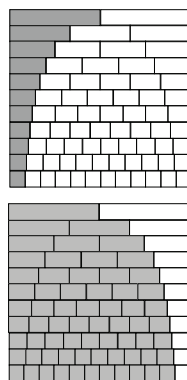

Answers

- (a) $\frac{6}{8}$ kg copper (b) $\frac{3}{8}$ kg copper (c) $\frac{5}{7}$ kg copper

(d) $\frac{9}{15}$ kg copper = $\frac{3}{5}$ kg copper (e) $\frac{8}{12}$ kg copper = $\frac{2}{3}$ kg copper

(f) $\frac{13}{15}$ kg copper (g) $\frac{8}{10}$ kg copper = $\frac{12}{15}$ kg copper
- $\frac{1}{12}; \frac{1}{11}; \frac{1}{10}; \frac{1}{9}; \frac{1}{8}; \frac{1}{7}; \frac{1}{6}; \frac{1}{5}; \frac{1}{4}; \frac{1}{3}; \frac{1}{2}$
- $\frac{1}{2}; \frac{2}{3}; \frac{3}{4}; \frac{4}{5}; \frac{5}{6}; \frac{6}{7}; \frac{7}{8}; \frac{8}{9}; \frac{9}{10}; \frac{10}{11}; \frac{11}{12}$
- (a) $\frac{2}{5}$ of 1 ℓ of milk (b) $\frac{2}{5}$ of 1 ℓ of milk

(c) $\frac{1}{3}$ of 750 ml of milk = $\frac{1}{2}$ of 500 ml of milk

3.4 Compare and order fractions

- Which weighs more, or is the mass the same?

You may find the diagrams useful.

(a) $\frac{6}{8}$ kg copper or $\frac{5}{7}$ kg copper

(b) $\frac{2}{7}$ kg copper or $\frac{3}{8}$ kg copper

(c) $\frac{5}{7}$ kg copper or $\frac{7}{10}$ kg copper

(d) $\frac{9}{15}$ kg copper or $\frac{3}{5}$ kg copper

(e) $\frac{8}{12}$ kg copper or $\frac{2}{3}$ kg copper

(f) $\frac{13}{15}$ kg copper or $\frac{17}{20}$ kg copper

(g) $\frac{8}{10}$ kg copper or $\frac{12}{15}$ kg copper

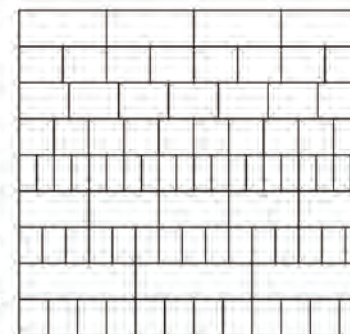

- Arrange the following 11 numbers from smallest to largest:

$\frac{1}{8}, \frac{1}{6}, \frac{1}{12}, \frac{1}{9}, \frac{1}{3}, \frac{1}{4}$

$\frac{1}{5}, \frac{1}{2}, \frac{1}{10}, \frac{1}{7}, \frac{1}{11}$

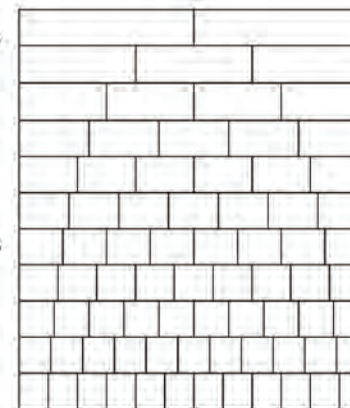

- Arrange the following 11 numbers from smallest to largest:

$\frac{7}{8}, \frac{5}{6}, \frac{11}{12}, \frac{8}{9}, \frac{2}{3}, \frac{3}{4}$

$\frac{4}{5}, \frac{1}{2}, \frac{9}{10}, \frac{6}{7}, \frac{10}{11}$

- Which is more milk, or is it the same volume of milk?

(a) $\frac{2}{5}$ of 1 ℓ of milk or $\frac{2}{5}$ of 500 ml of milk

(b) $\frac{2}{5}$ of 1 ℓ of milk or $\frac{1}{5}$ of 500 ml of milk

(c) $\frac{1}{3}$ of 750 ml of milk or $\frac{1}{2}$ of 500 ml of milk

Possible misconceptions

Again note that there is a dangerous misconception that is often accompanied by the misleading habit of referring to a fraction as “one number over another number”, for example reading $\frac{2}{3}$ as “two over three”. The misconception is that the numerator and denominator are two numbers that have similar meanings. This misconception is probably why learners make the error of adding the numerators and adding the denominators when adding fractions.

Teaching guidelines

The tinted passage at the bottom of page 139 is specifically phrased to combat the above misconception. Discuss it thoroughly in class. The *denominator* is the *name* of the fraction. (The Latin word *nomen* means name.)

Answers

5. There are a number of possibilities, of which the following are the most likely to be suggested:

$$(a) \frac{1}{2} = \frac{2}{4} = \frac{4}{8} = \frac{3}{6} = \frac{6}{12} \quad (b) \frac{1}{3} = \frac{5}{15} = \frac{2}{6} = \frac{3}{9} = \frac{4}{12}$$

$$(c) \frac{1}{4} = \frac{2}{8} = \frac{3}{12} = \frac{5}{20} \quad (d) \frac{1}{5} = \frac{3}{15} = \frac{2}{10} = \frac{4}{20}$$

Ask the class whether they see any patterns in their answers.

6. Several possibilities, e.g.

$$(a) \frac{4}{5} = \frac{12}{15} = \frac{8}{10} \quad (b) \frac{2}{3} = \frac{10}{15} = \frac{4}{6}$$

$$(c) \frac{6}{10} = \frac{3}{5} = \frac{12}{20} \quad (d) \frac{8}{12} = \frac{2}{3} = \frac{4}{6}$$

7. Several possibilities, e.g.

$$(a) \frac{3}{5} < \frac{7}{10}; \frac{2}{3}; \frac{3}{4} \quad (b) \frac{2}{3} < \frac{7}{10}; \frac{4}{5}; \frac{3}{4}$$

$$(c) \frac{3}{4} < \frac{9}{10}; \frac{4}{5}; \frac{11}{12} \quad (d) \frac{7}{8} < \frac{9}{10}; \frac{8}{9}; \frac{11}{12}$$

8. Several possibilities, e.g.

$$(a) \frac{1}{5} > \frac{1}{10}; \frac{3}{20}; \frac{2}{15} \quad (b) \frac{3}{8} > \frac{1}{4}; \frac{1}{6}; \frac{1}{3}$$

$$(c) \frac{3}{4} > \frac{7}{10}; \frac{3}{5}; \frac{1}{2} \quad (d) \frac{1}{3} > \frac{1}{6}; \frac{1}{5}; \frac{3}{10}$$

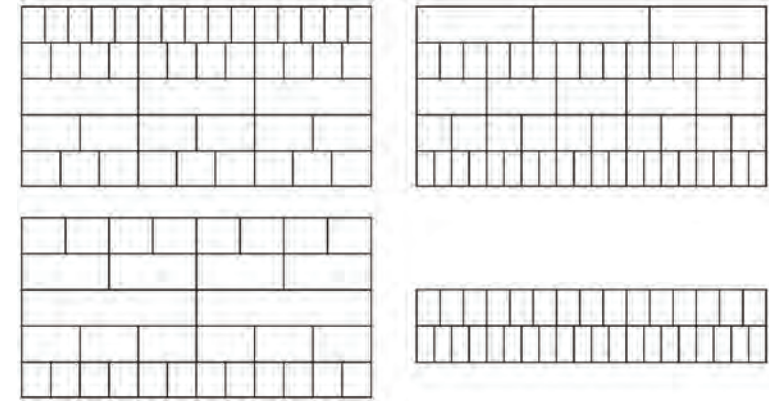

$\frac{6}{8}$, $\frac{9}{12}$ and $\frac{15}{20}$ are all equivalent to $\frac{3}{4}$.

5. Name at least two fractions that are equivalent to each of the following. (You may use the above diagrams.)

$$(a) \frac{1}{2} \quad (b) \frac{1}{3} \quad (c) \frac{1}{4} \quad (d) \frac{1}{5}$$

6. Name two fractions that are equivalent to each of the following.

$$(a) \frac{4}{5} \quad (b) \frac{2}{3} \quad (c) \frac{6}{10} \quad (d) \frac{8}{12}$$

7. Name three fractions that are bigger than each of the following.

$$(a) \frac{3}{5} \quad (b) \frac{2}{3} \quad (c) \frac{3}{4} \quad (d) \frac{7}{8}$$

8. Name three fractions that are smaller than each of the following.

$$(a) \frac{1}{5} \quad (b) \frac{3}{8} \quad (c) \frac{3}{4} \quad (d) \frac{1}{3}$$

The name of a fraction, for example third, fifth or eighth, tells us into how many equal parts the whole or the measuring unit is divided. The name indicates the size of the part and therefore the unit in which we measure. It is called the **denominator** of the fraction.

The number of parts, for example the “three” in three ninths, is called the **numerator**. It indicates how many of the parts are counted.

3.5 Count in fractions on the number line

Possible misconceptions

The major and dangerous misconception that a fraction is not a single number but a combination of two numbers “above and below the line”, or “the numerator and the denominator”, is unfortunately widespread. The misconception is supported by

- premature introduction of the common fraction notation before the fraction concept is properly developed,
- insufficient experience in referring to fractions in terms of the actual fraction names, for example “five eighths”,
- the flawed misnaming of fractions as “a number over another number”, for example of $\frac{5}{8}$ as “5 over 8” instead of “5 eighths”, and
- confusion between two uses of a horizontal line between two numbers.

Representing fractions on the number line is one way in which this misconception can be resisted. It supports the understanding of a **fraction as a single number** that occupies a specific position between other numbers (including whole numbers) on the number line.

Notes on questions

On measuring tapes, parts of the number symbols are often not printed to save space, for example ... 80 90 100 10 20 30... instead of ... 80 90 100 110 120 130...

When answering the questions in this section, learners should preferably write the number symbols in full, as indicated in the answers below.

Answers

1. $\frac{7}{5}$ or $1\frac{2}{5}$ Brownsticks long
2. (a) $\frac{3}{5}$ (b) $\frac{5}{5}$ or 1 (c) $\frac{8}{5}$ or $1\frac{3}{5}$
3. $\frac{6}{5} = 1\frac{1}{5}$ $\frac{7}{5} = 1\frac{2}{5}$ $\frac{8}{5} = 1\frac{3}{5}$ $\frac{9}{5} = 1\frac{4}{5}$
4. $\frac{3}{4}$ $\frac{4}{4}$ or 1 $\frac{5}{4}$ or $1\frac{1}{4}$ $\frac{6}{4}$ or $1\frac{2}{4}$ $\frac{7}{4}$ or $1\frac{3}{4}$
5. $\frac{3}{6}$ $\frac{4}{6}$ $\frac{5}{6}$ $\frac{6}{6} = 1$ $\frac{7}{6} = 1\frac{1}{6}$ $\frac{8}{6} = 1\frac{2}{6}$ $\frac{9}{6} = 1\frac{3}{6}$ $\frac{10}{6} = 1\frac{4}{6}$ $\frac{11}{6} = 1\frac{5}{6}$
6. $\frac{1}{10}$ $\frac{2}{10}$ $\frac{3}{10}$ $\frac{4}{10}$ $\frac{5}{10}$ $\frac{6}{10}$ $\frac{7}{10}$ $\frac{8}{10}$ $\frac{9}{10}$ $\frac{10}{10}$ or 1 $1\frac{1}{10}$ $1\frac{2}{10}$ $1\frac{3}{10}$ $1\frac{4}{10}$ $1\frac{5}{10}$ $1\frac{6}{10}$ $1\frac{7}{10}$ $1\frac{8}{10}$ $1\frac{9}{10}$

3.5 Count in fractions on the number line

A ruler can be marked in more detail, as shown below.

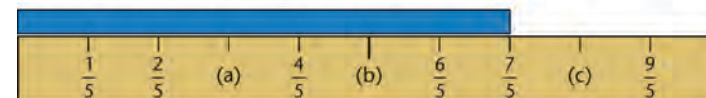

This ruler is 2 Brownsticks long.

1. How long is the blue strip above the ruler?
2. What numbers should be written at (a), (b) and (c) on the above ruler?
3. Write the numbers $\frac{6}{5}$, $\frac{7}{5}$, $\frac{8}{5}$ and $\frac{9}{5}$ in another way.
4. Write down the numbers that are missing from the ruler below, from left to right.

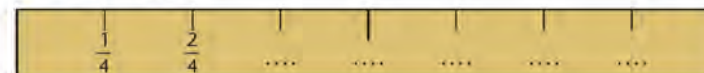

5. Write down the numbers that are missing from the ruler below, from left to right.



6. Write down the numbers that should be at the marks on the tenths-ruler below, from left to right.



To answer the last question, you actually counted in tenths up to 19 tenths:

One tenth, two tenths, three tenths, four tenths 19 tenths.

You may have written it as $\frac{1}{10}$, $\frac{2}{10}$, $\frac{3}{10}$, $\frac{4}{10}$, $\frac{5}{10}$, up to $\frac{19}{10}$.

Notes on questions

For the purposes of this section, it makes no difference whether learners write, for example, $\frac{18}{12}$, $1\frac{6}{12}$ or $1\frac{1}{2}$.

Answers

7. $\frac{1}{12}$ $\frac{2}{12}$ $\frac{3}{12}$ $\frac{4}{12}$ $\frac{5}{12}$ $\frac{6}{12}$ $\frac{7}{12}$ $\frac{8}{12}$ $\frac{9}{12}$
 $\frac{10}{12}$ $\frac{11}{12}$ $\frac{12}{12} = 1$ $1\frac{1}{12}$ $1\frac{2}{12}$ $1\frac{3}{12}$ $1\frac{4}{12}$ $1\frac{5}{12}$ $1\frac{6}{12}$ $1\frac{7}{12}$ $1\frac{8}{12}$ $1\frac{9}{12}$ $1\frac{10}{12}$ $1\frac{11}{12}$ $1\frac{12}{12} = 2$
8. $\frac{1}{8}$ $\frac{2}{8}$ $\frac{3}{8}$ $\frac{4}{8}$ $\frac{5}{8}$ $\frac{6}{8}$ $\frac{7}{8}$ $\frac{8}{8} = 1$ $1\frac{1}{8}$ $1\frac{2}{8}$ $1\frac{3}{8}$ $1\frac{4}{8}$ $1\frac{5}{8}$ $1\frac{6}{8}$ $1\frac{7}{8}$ $1\frac{8}{8} = 2$ $2\frac{1}{8}$ $2\frac{2}{8}$
 $2\frac{3}{8}$ $2\frac{4}{8}$ $2\frac{5}{8}$ $2\frac{6}{8}$ $2\frac{7}{8}$ $2\frac{8}{8} = 3$
9. (a) $\frac{1}{7}$ (b) $\frac{6}{7}$ (c) $2\frac{2}{7}$
(d) $\frac{3}{5}$ (e) $1\frac{1}{5}$ (f) 2

3.6 Solve problems

Teaching guidelines

Do not require learners to read and interpret question 1 themselves. Rather tell them that Mrs Faku has a *pile of cookies* and that she hands out all the cookies to her two sons, in the way described.

Then ask them what part of the cookies the older son gets, and what part the younger son gets, *but do not allow learners to give public answers in class*. It is critical that each learner has the opportunity to engage individually with this question, which allows the formation of some intuitive understanding of ratio.

Answers

1. (a) Older son: $\frac{2}{3}$; younger son: $\frac{1}{3}$
(b) 24 and 12 cookies respectively
2. Less, because $\frac{1}{4} < \frac{1}{3}$ of a milk tart. (If there are 15 people and 5 milk tarts, each person can eat one third of a milk tart.)

7. Count in twelfths up to 2. Write the numbers in symbols as you go along. While you count you may think of moving in steps of one twelfth on the number line.



8. Count in eighths up to 3. Write the numbers in symbols as you go along.
9. Write the numbers that should be at the arrows on the number lines below.

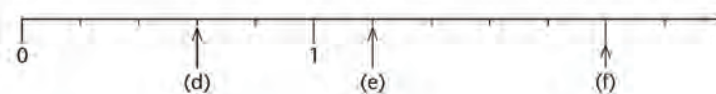

3.6 Solve problems

1. Mrs Faku has two sons. When she gives them cookies to eat, she gives two cookies to the older son for every one cookie that she gives to the younger son.
- (a) What fraction of all the cookies that she gives them does each of the sons get?
- (b) If she gives them 36 cookies in total, how many cookies does each son get?
2. There are 15 people at a party and 5 milk tarts. Thulisile eats $\frac{1}{4}$ of a milk tart. Is that more or less than her fair share? Explain your answer.

Answers

3. one third ($\frac{1}{3}$)
4. one quarter ($\frac{1}{4}$)
5. $1\frac{3}{5}$ blocks of butter (1 block and three fifths of a block)
6. (a) $\frac{5}{6}$ of a Brownstick long
(b) one Brownstick long
(c) one and three twelfths ($1\frac{3}{12}$) of a Brownstick long
7. (a) $\frac{3}{8}$ kg (b) $\frac{7}{10}$ kg
8. (a) $\frac{3}{12}$ kg (b) $\frac{8}{12}$ kg

3. 72 learners are divided equally into three classes. Each class has its own classroom. What fraction of all the learners are in each of the classrooms?
4. A mother shares the peaches that she bought equally among her four children. What fraction of all the peaches does each of the children get?
5. Pienie uses about 2 fifths of one small block of butter to bake one batch of rusks. How much butter does she need for four batches of rusks?
6. Each ruler below is 2 Brownsticks long.

(a) How long are the two red strips together?



(b) How long are the two blue strips together?



(c) How long are the three yellow strips together?



7. How much is each of the following?
 - (a) $\frac{1}{8}$ kg + $\frac{1}{8}$ kg + $\frac{1}{8}$ kg of meat
 - (b) $\frac{3}{10}$ kg + $\frac{4}{10}$ kg of meat
8. (a) How many twelfths of a kilogram is $\frac{1}{4}$ kg?
(b) How much is $\frac{1}{4}$ kg sugar + $\frac{5}{12}$ kg sugar?

Grade 5 Term 2 Unit 4 Length

Learner Book Overview		
Sections in this unit	Content	Pages in Learner Book
4.1 Know the measuring units	Metric units of length: need for them, developing a feel for them, choosing appropriate units	143 to 145
4.2 Estimate and measure	Using rulers, measuring tapes, builder's tape measures, trundle wheels Estimating and measuring lengths in millimetres, centimetres, metres and kilometres	145 to 149
4.3 Converting units	Converting between metric units of length	149 to 151
4.4 Rounding off with units of measurement	Rounding off to particular metric units of length, and to 5, 10, 100, 1 000	152 to 153
4.5 Problem solving	Solving problems within the context of length and distance	154 to 156

CAPS time allocation	6 hours
CAPS page references	25 and 163 to 165

Mathematical background

Length, mass, capacity/volume and area are different properties of objects. When we measure these properties of objects, we are using a numerical value to describe how much of that property (in this case *length*) we have. This allows us to compare and order objects in terms of their length, for example: "The board is longer than the teacher's desk." It also allows us to do calculations, for example: "If a roll of string is 500 m, is this enough string to give each Intermediate Phase learner a 2 m length if there are 4 classes with 40 learners in each grade?"

Learners go through four stages when learning to measure:

- Identifying and understanding the property they are measuring**
Most Grade 5 learners should know when they are measuring length, mass or capacity/volume.
- Comparing and ordering examples of a particular measure**
Young learners place objects directly against each other when measuring length. This becomes less efficient when many objects have to be measured.
- Using informal or non-standard units to measure** (see question 1 of Section 4.1)
Learners choose one object, such as a hand or a foot, to use as a unit to measure and quantify many objects. This method does not work very well, because people's hands differ in width, and an adult's foot is longer than a child's foot.
- Using formal or standard units to measure** (see Sections 4.2, 4.3, 4.4 and 4.5)
This allows people in different places to measure, quantify and compare objects using the same measure.

By Grade 5 most learners are comfortable using a ruler to measure in centimetres and millimetres, and find it easy to use a metre stick. However, many learners find it difficult to use a builder's tape measure, and many have little or no experience using a trundle wheel (see Section 4.4, question 10).

Resources

Rulers (two photocopyable rulers are given in the Addendum on page 417), measuring tapes, metre sticks, builder's tape measures, trundle wheel (if available), roll of string, scissors, koki-pens, correction fluid

4.1 Know the measuring units

Teaching guidelines

In this section, learners first work with informal units, discuss the potential problems with these and then move on to working with standard metric units.

You can refer to the tinted passage to explain that although we tend to measure in kilometres, metres, centimetres and millimetres, other metric units of measurement do exist. This will be touched on again in Section 4.3.

Answers

- The question is really: “How many pencils is the length of your book?” Learners’ answers will vary. Some learners may say that they get a number of whole pencil lengths and then part of a pencil length. Learners may find it difficult to be specific about the size of the part pencil lengths.
 - Move around the class and try to hear what the learners are saying to each other.
 - Learners’ answers will vary. Learners may say that it is difficult to compare lengths of books using pencil lengths, as pencil lengths vary (see the first tinted passage on page 143 of the Learner Book).
 - Ask one or two learners for their reasons.
- Learners’ answers will vary, but may include the following:
 - to find out their size
 - to compare sizes
 - to be able to do calculations around size.
 - If everyone used their own unit, people would get confused when they tried to tell each other how big something is. For example, if you wanted to buy material for a dress and said: “I need material that is 30 pencils in length”, what could happen? The shopkeeper might have a shorter pencil than you do, and so you would get less material than you expected. For this reason we have standard units of length, such as the metre. Both you and the shopkeeper know how long a metre is.

How to read the table on page 143

Begin at the left, and let learners read across to the right: 1 kilometre is the same length as 10 hectometres; 10 hectometres is the same length as 100 decametres; 100 decametres is the same length as 1 000 metres; 1 000 metres is the same length as 10 000 decimetres, which is the same as 100 000 centimetres, which is the same as 1 000 000 millimetres. And so, 1 kilometre is the same length as 1 000 000 millimetres!

UNIT

4

LENGTH

4.1 Know the measuring units

- Measure the length of your book using your pencil.
 - What problem do you experience with this measurement?
 - Find out if your classmates have the same problem. Discuss this with one or two of your classmates.
 - Is it useful to know what the length of an object is if the measurement was done with a pencil?
 - Discuss the reasons for your answer to question (c) with one or two of your classmates.

You have just used your pencil to measure the length of your book. Your pencil was the **unit of measurement**. However, a pencil is not a standard unit of measurement because all pencils are not all the same length.

- Discuss the following with a few classmates:
 - Why do we measure things?
 - Why is it necessary to have standard units of measurement?

In South Africa, we use the **metric (decimal) system**, which is a standard system of measurement. Each unit is always the same size. This system is easy to use. To change from one unit to another, we divide by 10 (or multiples of 10), or multiply by 10 (or multiples of 10). Below is a table of standard units. This year, we will use the units km, m, cm and mm only.

Kilometre (km)	Hectometre	Decametre	Metre (m)	Decimetre	Centimetre (cm)	Millimetre (mm)
1	10	100	1 000	10 000	100 000	1 000 000

Teaching guidelines

Learners have not yet engaged with hundredths and thousandths in the work on fractions. Explain to them that when an object is divided into 100 equal parts, each part is called one hundredth of the whole. Similarly, when an object is divided into 1 000 equal parts, each part is called one thousandth of the whole.

Answers

3. (a) cm; *or* m and cm
(b) cm; *or* cm and mm
(c) km
(d) m; *or* m and cm
(e) mm

The **standard unit** of measuring length in the International System of Units (the SI) is the **metre** (m). All the other units are named according to their relationship with the 1 m unit.

A **centimetre** (cm) is the length of each of the parts if 1 m is divided into 100 equal parts.

$$100 \text{ cm} = 1 \text{ m}$$

Centi- in **centimetre** means **hundredth**.

A **millimetre** is one of the parts that is formed when 1 m is divided into 1 000 equal parts.

$$1\,000 \text{ mm} = 1 \text{ m}$$

Milli- in **millimetre** means **thousandth**.

A **kilometre** (km) is **1 000 times** as long as 1 m.

$$1\,000 \text{ m} = 1 \text{ km}$$

Kilo- in **kilometre** means **thousand**.

The rulers and tape measures that you already know are marked in centimetres and millimetres. Your teacher can show you another commonly used ruler. It is 1 m long and is called a **metre stick**.

3. Which unit will you use if you have to measure the length of each of the objects below: millimetre, centimetre, metre or kilometre?

$$10 \text{ mm} = 1 \text{ cm}$$

- (a) the height of one of your classmates
(b) the length of your pencil
(c) the distance between two towns
(d) the height of a wall of a building
(e) the width of your fingernail

Answers

- Answers will vary. Examples are: width of a small eraser; width of a pen; width of a tube of lip-salve; width of the ear of a mug. Learners may also say: width of one of their fingers.
- Answers will vary. Examples include: length of a cell phone; width of an envelope; width of a sheet of A4 paper folded lengthwise; width of some learners' palms.
- Answers will vary. Examples include: length of a ruler; length of an A4 sheet of paper; width of a chopping board.
- Answers will vary. Examples include: width or length of a desk or table; width of two sheets of newspaper; a long stride of an adult; width of a door; height of some classroom windows.
- (a) Answers will vary. Approximately 3 to 5 cm.
(b) Answers will vary. Approximately 1 m.
(c) Answers will vary. Approximately $2\frac{1}{2}$ m.

4.2 Estimate and measure

Mathematical notes

Estimating before measuring can help learners to check whether they have made a mistake when measuring. This is particularly useful when measuring lengths of more than a few metres. However, before learners can estimate lengths they need to have a feel for those lengths. It is also useful to find referents for commonly measured lengths (see Section 4.1, questions 4, 5, 6 and 7). The aim is to use these to estimate other lengths.

When learners take measurements, especially where measurements will vary quite a lot, let them collate and keep these measurements. Use them for data handling. Learners can sort, organise, represent and analyse the data. Examples include Section 4.2, questions 1(a) on Learner Book page 145 (see alongside), 6(g) on Learner Book page 148, and 9(c) and (d) on Learner Book page 149.

Answers

- (a) Answers will vary.
(b) Learners might say that they did not experience any problems with the task, but there are difficulties: the bottom ends of some pencils are rounded, not flat, and this makes it difficult to align them with zero on the ruler; some learners' pencils are sharpened at both ends, and this makes it hard to see just where the points are above the scale on the ruler.
- Pencil above ruler: 8 cm; pencil below ruler: $3\frac{1}{2}$ cm

- Name three objects that are about the length of a centimetre. (Hint: look at your hands or look around in the classroom.)
- Name three objects that are about 10 cm long or wide.
- Name three objects that are about 30 cm long or wide.
- Name three objects that are about 1 m long or wide.
- Now use some of the objects that you named in questions 4 to 7 to help you estimate the following:
 - the length of your eraser
 - the length of your teacher's table
 - the height of your classroom wall

4.2 Estimate and measure

When you measure the length (or width or height) of an object with your ruler, remember the following:

- Make sure that the one end of the object that you measure is on the 0 mark of the ruler.
- Read the measurement where the other end of the object is.
- Make sure that your line of sight is perpendicular to the ruler. Your eyes should be exactly above the point where you are reading on the ruler.

- (a) Estimate and then measure the length of your pencil.
(b) What problems did you have with this task? Write them down.
- Measure the pencils:



Mathematical notes

The more learners first estimate and then measure lengths, the better they will become at both estimating and measuring. You may need to encourage learners to estimate the lengths *before* measuring because sometimes learners measure first, round off the measurement and then present that as an estimate. This way of doing it does not build the skill of estimation, nor does it help learners to check whether their measurements or their estimates are reasonable.

Teaching guidelines

You can remind learners to use the referents for 1 cm, 10 cm, and 30 cm that they developed in the previous section to estimate the lengths of the bars. Ask them questions such as: “*Are the bars longer or shorter than 10 cm, longer or shorter than 20 cm?*”, “*About how many times longer than 1 cm are they?*”

Answers

3.

Bar	Estimated length	Measured length
Red	Around 10 to 12 cm	9 cm 7 mm
Purple	Around 10 cm	7 cm 3 mm
Yellow	Around 5 to 6 cm	4 cm 5 mm
Green	Around 11 to 15 cm	12 cm 8 mm
Grey	Around 10 to 12 cm	11 cm 0 mm

3. First estimate the lengths in centimetres of each of the bars below. Then measure each length with your ruler.

Copy this table and fill in the estimated lengths and the measured lengths. Write your measured lengths as centimetres and millimetres.

Bar	Estimated length	Measured length
Red		
Purple		
Yellow		
Green		
Grey		



Mathematical notes

Many people find it more difficult to estimate the length of a curved line than a straight line.

Teaching guidelines

Cut a piece of string about 20 cm long for each learner.

Notes on questions

In question 4(b) it is difficult to measure the curved lines exactly. Discuss with learners the difficulties they experience when measuring these lines.

What question 5 really asks, is for learners to draw straight lines with lengths 2 cm, 8 cm, 12 cm and 15 cm *without using a ruler*. They will learn more going through this process than they will by drawing “better estimated lengths” while looking at the markings on their ruler.

Answers

4. (a) Lay the piece of string along each object. Grip it at the point where the object ends. Measure the piece of string from the end to that point.
 (b) Accept answers that are within a few millimetres of those stated below.

Object	Estimated length	Measured length
The length of the red wire	Expect estimates of about 10 cm	8 cm 2 mm
The length of the purple wire	Expect estimates of about 20 cm	17 cm 3 mm
The distance around the yellow disc	Expect estimates of about 6 to 12 cm	8 cm 7 mm
The distance around the green object	Expect estimates of about 7 to 10 cm	7 cm 4 mm

5. Ask learners to use their rulers to draw accurate length lines next to the estimated lines. For each length (2 cm, 8 cm, etc.), ask how many of them came close to the length they had to estimate. Celebrate their successes!

4. (a) Discuss with a classmate how you can use a piece of string to find the lengths and distances described in the table below.
 (b) For each of the objects, first estimate and then measure the length. Copy this table and fill in the estimated and measured lengths.



Object	Estimated length	Measured length
The length of the red wire		
The length of the purple wire		
The distance around the yellow disc		
The distance around the green object		

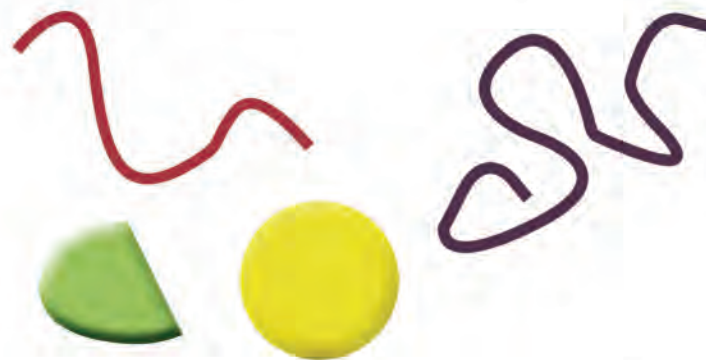

5. Use a folded sheet of paper as a straight edge and draw lines that you think have approximately the following lengths: 2 cm; 8 cm; 120 mm; 15 cm.
 Now use your ruler to measure your lines, and to see how accurate your estimates were.

Teaching guidelines

If possible, try to get a builder's tape measure. These tape measures are usually 5 m long, and are made of a metal strip that rolls up into a neat plastic case. You can find them at any hardware shop and they cost about R20 to R30. Ask the principal about the school's budget for mathematics equipment – the school can use the same tape measure year after year. (Note: Don't pull the tape out all the way past 5 m or the spring might come loose.) If you cannot get a builder's tape measure, ask some learners to help you prepare pieces of measuring string, like this:

Take a ruler and measure and mark, with correction fluid, a length of 1 m on a table. Then lay the string along that "line". Tie a knot at one end; *this is the zero mark*. Now place the knot on the beginning of the line and put your finger at the other end, on the 1 m mark. Tie another knot there. Check that the length between the two knots is really 1 m. Now repeat; from the last knot, measure 1 m of string and find the place to tie the next knot. So you have three knots, marking the positions 0 m, 1 m and 2 m. Carry on and tie knots at 3 m, 4 m, 5 m, all the way to 10 m. (You need a long piece of string!)

On the day of the lesson, show the learners the 10 m measuring string. Ask them where you should put a mark to show a length of 0,5 m. Use a koki-pen to put a mark there, in the middle between the 0 m knot and the 1 m knot. They will soon see that you can put koki-pen marks at 1,5 m, 2,5 m, 3,5 m, and so on.

In question 6, ask learners to estimate the width of the classroom and the height of the door. Then use the measuring string to measure these lengths. Get them to measure more lengths or distances longer than 2 m. This will require them to estimate longer distances in metres. It will also encourage them not just to read off the final numbers, for example 66 cm, but to think about how many metres come before the numbered intervals.

For question 9 you really need enough tape measures for the class, but if you have only the string you can still get value from it. Learners will soon see that markings at 1 m and 0,5 m spacings do not give a very precise answer. The answer will be something like: "The classroom is between 7 m and 7,5 m wide". Ask learners how they could get a more precise measurement. They will soon see that they can make more marks at 0,1 m, 0,2 m, 0,3 m, 0,4 m, and so on.

Answers

6. Learners' estimates will vary; in question 8 they will check their estimates with a measuring instrument.
7. (a) Builder's tape measure or measuring tape
(b) Builder's tape measure or trundle wheel (c) Measuring tape
(d) Measuring tape (e) Ruler (f) Ruler
8. (a) and (b) Learners' own practical work

6. Estimate the following lengths and write down the answers, one below the other:
 - (a) the height of your school desk or table
 - (b) the width of the classroom door
 - (c) the width of the classroom
 - (d) the thickness of your eraser
 - (e) the length of a wall in your classroom
 - (f) the thickness of your pencil
 - (g) the length of your foot

Estimating does not give you the exact length, width, height or thickness, but it helps you to get an idea of the size of these measurements and the units in which they are measured.

7. The following measuring instruments are available:
a ruler, a measuring tape or metre stick, a builder's tape measure longer than 5 m, a trundle wheel.
Which of these instruments will you use to measure the following?
 - (a) the height of the classroom wall
 - (b) the distance around the playground at school
 - (c) the length of a curtain
 - (d) the length of material for making a dress
 - (e) the length of your pencil
 - (f) the thickness of this textbook
8. Now, measure the objects and distances in question 6.
 - (a) Write down the measured lengths next to the estimated lengths.
 - (b) How close are your estimates to the actual measurements?
Discuss this with a classmate.

Answers

9. (a), (c), (d) Learners' estimates and measurements will vary.
(b) Learners' estimates will vary; width of textbook: close to 16 cm and 8 mm
10. (a) Learners' own practical work (b) Learners' own estimates

4.3 Converting units

Mathematical notes

Learners can learn these conversion factors off by heart. However, as with everything learnt off by heart, learners will sometimes forget the conversion factors and use an incorrect one. It may be better for learners to understand how the relationship between metric units works in general: see the table on page 143 in the Learner Book.

Teaching guidelines

kilometre	hectometre	decametre	metre	decimetre	centimetre	millimetre
			$1\frac{5}{10} = 1\frac{1}{2} = 1,5$ ($150 \div 10 \div 10 = 1,5$)		150	

Learners can use a table like the one above to do conversions. They simply work as follows:

- They write the number under the correct unit and then mark which unit they are converting to, for example to convert 150 cm to metres, they write 150 in the "centimetre" column and make a mark (e.g. a small dot or cross) in the metre column.
- If converting from a unit of a lower power to a unit of a higher power, they divide by 10 each time they move to a unit of a higher power. So, in this example, they divide 150 by 10 and then by 10 again, to get to metres.
- If converting from a unit of a higher power to a unit of a lower power, they multiply by 10 each time they move to a unit of a lower power. So, in this example, to get from 1,5 m to centimetres, they multiply 1,5 by 10 and then by 10 again.

See page 416 in the Addendum for a model that may be used to teach conversion between units of measurement as well as a mnemonic that learners may use to remember the order of the units of measurement.

Answers

1. (a) Divide by 100 (b) Divide by 10 (c) Divide by 1 000
(d) 500 cm (e) 60 mm (f) 9 000 mm
2. (a) 10 cm = 100 mm (b) 300 mm = 30 cm (c) 100 cm = 1 000 mm
(d) 20 mm = 2 cm (e) 180 cm = 1 800 mm (f) 600 mm = 60 cm

9. Estimate the following and write down the estimates. Afterwards, take exact measurements and write them next to the estimates.
- (a) the height of your chair
(b) the width of this textbook
(c) the distance from your elbow to the tip of your middle finger
(d) the width of your thumbnail
10. (a) Do you know how far a kilometre is? Go to a safe, familiar place and measure the distance of 1 km using a trundle wheel.
(b) Estimate the distance that you live from school.

4.3 Converting units

When we write a measurement in another unit, we say we **convert** from one unit to the other. Our system of units is a decimal system. That makes it easy to convert from one unit to another, because each unit is 10, 100 or 1 000 times as large or as small as another unit in the system. Look again at the table on page 143.

$$\begin{array}{ll} 1 \text{ m} = 1\,000 \text{ mm} & 1 \text{ km} = 1\,000 \text{ m} \\ 1 \text{ cm} = 10 \text{ mm} & 1 \text{ m} = 100 \text{ cm} \end{array}$$

1. (a) How would you convert centimetres to metres?
(b) How would you convert millimetres to centimetres?
(c) How would you convert millimetres to metres?
(d) How many centimetres are there in 5 m?
(e) How many millimetres are there in 6 cm?
(f) How many millimetres are there in 9 m?
2. Complete by writing the length in the given unit.
(a) 10 cm = ____ mm (b) 300 mm = ____ cm
(c) 100 cm = ____ mm (d) 20 mm = ____ cm
(e) 180 cm = ____ mm (f) 600 mm = ____ cm

Notes on questions

In this section, learners get plenty of practice converting units. You may want to split the questions between classwork and work for additional practice (e.g. homework), so that you have enough time for Sections 4.4 and 4.5. One possibility is to use questions 1, 2, 5, 6, 9, 10 and 11 for classwork, and the rest for additional practice.

Answers

3.	mm	20	50	30	180	90	40	100	1 000	130	540	430	4 300
	cm	2	5	3	18	9	4	10	100	13	54	43	430

4. (a) $480 \text{ cm} = 4\frac{8}{10} \text{ m}$ (b) $560 \text{ mm} = 56 \text{ cm}$
 (c) $30 \text{ m} = 3\,000 \text{ cm}$ (d) $20 \text{ m} = 20\,000 \text{ mm}$
 (e) $300 \text{ mm} = 30 \text{ cm}$ (f) $750 \text{ mm} = \frac{3}{4} \text{ m}$

5. (a)

mm	4 000	8 000	6 000	2 000	9 000	1 000
cm	400	800	600	200	900	100
m	4	8	6	2	9	1

(b)

mm	12 000	3 000	5 000	6 000	9 000	75 000
cm	1 200	300	500	600	900	7 500
m	12	3	5	6	9	75

6. (a) $1 \text{ km} = 1\,000 \text{ m}$ (b) $1\,000 \text{ m} = 1 \text{ km}$
 (c) $20 \text{ km} = 20\,000 \text{ m}$ (d) $3\,500 \text{ m} = 3\frac{1}{2} \text{ km}$
 (e) $450 \text{ km} = 450\,000 \text{ m}$ (f) $300 \text{ m} = \frac{3}{10} \text{ km}$

7.

m	2 000	8 500	18 000	134 000	28 000	500	176 000	4 500	5 500
km	2	$8\frac{1}{2}$ or 8,5	18	134	28	$\frac{1}{2}$	176	4,5	$5\frac{1}{2}$ or 5,5

3. Copy and complete the table.

mm	20	30	90	100	130	540	
cm	5	18	4	100		43	430

4. Complete by writing the length in the given unit.

- (a) $480 \text{ cm} = \underline{\hspace{1cm}} \text{ m}$ (b) $560 \text{ mm} = \underline{\hspace{1cm}} \text{ cm}$
 (c) $30 \text{ m} = \underline{\hspace{1cm}} \text{ cm}$ (d) $20 \text{ m} = \underline{\hspace{1cm}} \text{ mm}$
 (e) $300 \text{ mm} = \underline{\hspace{1cm}} \text{ cm}$ (f) $750 \text{ mm} = \underline{\hspace{1cm}} \text{ m}$

5. Copy and complete the tables.

(a)

mm	4 000			2 000		1 000
cm	400	800				
m	4		6		9	

(b)

mm			5 000			75 000
cm		300		600		
m	12				9	

6. Complete:

- (a) $1 \text{ km} = \underline{\hspace{1cm}} \text{ m}$ (b) $1\,000 \text{ m} = \underline{\hspace{1cm}} \text{ km}$
 (c) $20 \text{ km} = \underline{\hspace{1cm}} \text{ m}$ (d) $3\,500 \text{ m} = \underline{\hspace{1cm}} \text{ km}$
 (e) $450 \text{ km} = \underline{\hspace{1cm}} \text{ m}$ (f) $300 \text{ m} = \underline{\hspace{1cm}} \text{ km}$

You know that $1\,000 \text{ m} = 1 \text{ km}$. You can write $1\,500 \text{ m}$ as $1 \text{ km} + 500 \text{ m}$ or as $1\frac{1}{2} \text{ km}$.

Other ways to write this are $1,500 \text{ km}$ and $1,5 \text{ km}$. The 1 tells you that you have 1 full kilometre and the 0,5 or 0,500 tells you that you have another $\frac{1}{2} \text{ km}$.

7. Copy and complete the table.

m	2 000	8 500			28 000		176 000		5 500
km			18	134		$\frac{1}{2}$		4,5	

Notes on questions

Question 9 prepares learners for question 10. It is useful for learners to answer questions 9(a), (b) and (c) before answering question 10.

Answers

8. (a) 5 892 m = 5 km and 892 m (b) 17 056 m = 17 km and 56 m
(c) 8 331 m = 8 km and 331 m (d) 23 451 m = 23 km and 451 m
(e) 2 003 m = 2 km and 3 m (f) 100 400 cm = 1 km and 4 m
9. (a) $\frac{1}{2}$ m (b) $\frac{1}{4}$ m (c) 25 cm
10. (a) 125 cm (b) 250 cm (c) 175 cm
11. (a) 7 035 m (b) 8 m and 4 mm (c) 3 m and 8 cm and 2,5 mm
(d) 10 m and 40 cm (e) 36 m and 71 cm (f) 4 250 m
12. Yes, but only by converting the lengths to the same unit.
13. (a) 82 km and 894 m (b) 19 km and 55 m
(c) 679 m and 38 cm (d) 3 m and 6 cm and 7 mm
(e) 788 m and 29 cm (f) 80 km and 757 m
14. (a) 52 km and 894 m (b) 55 m
(c) 668 m and 62 cm (d) 2m and 47 cm and 3 mm
(e) 612 m and 21 cm (f) 65 km and 757 m
15. Learners' methods will vary.
(a) $12\frac{1}{2}$ m; $\frac{3}{4}$ m; 643 cm; 870 mm
(b) 1,5 km; 1 230 m; 21 877 cm
(c) 521 027 m; 861 490 cm; $1\frac{1}{2}$ km; 0,5 km; 91 499 mm; 556 cm
(d) 25 km; 20 000 m; 150 000 cm

8. Write the following distances as kilometres and metres.

Example: 2 345 m = 2 km and 345 m

- (a) 5 892 m (b) 17 056 m (c) 8 331 m
(d) 23 451 m (e) 2 003 m (f) 100 400 cm
9. (a) We know that 1 m = 100 cm. Write 50 cm in metres.
(b) What is half of 50 cm? Give your answer in metres.
(c) What is half of 50 cm? Give your answer in centimetres.
10. Write the following in cm:
(a) $1\frac{1}{4}$ m (b) $2\frac{1}{2}$ m (c) $1\frac{3}{4}$ m
11. We can write 6 257 mm as 6 m and 25 cm and 7 mm. Write the following as m, cm and mm:
(a) 7 035 m (b) 8 004 mm (c) $308\frac{1}{4}$ cm
(d) 10 400 mm (e) 3 671 cm (f) $4\frac{1}{4}$ km
12. Is it possible to add lengths that are expressed in different units? Explain your answer.
13. Add the following distances or lengths:
(a) 15 km + 67 894 m (b) 9 555 m + $9\frac{1}{2}$ km
(c) 674 m + 538 cm (d) 304 cm + 567 mm
(e) 70 025 cm + 88 040 mm (f) 73 257 m + $7\frac{1}{2}$ km
14. Now, for each of the lengths (or distances) in question 13, subtract the shorter one from the longer one.
15. Write the following lengths in descending order (from longest to shortest) and write down how you decided on this order.
(a) 643 cm; $12\frac{1}{2}$ m; 870 mm; $\frac{3}{4}$ m
(b) 1,5 km; 1 230 m; 21 877 cm
(c) 556 cm; $1\frac{1}{2}$ km; 861 490 cm; 91 499 mm; 521 027 m; 0,5 km
(d) 20 000 m; 25 km; 150 000 cm

4.4 Rounding off with units of measurement

Mathematical notes

We can round off to the nearest unit of measurement or we can round off to the nearest multiple of a number, for example 5, 10, 100, 1 000. In this section, learners are asked to round off in both these ways.

Measurement provides a useful context for learners to understand rounding off. In particular, questions that ask “is it closer to . . . or is it closer to . . .” help learners to understand rounding off.

Teaching guidelines

You should do an activity with the class to explain the simplest kind of “rounding off”. Use your board ruler to draw a line on the board, a little less than a metre long. The board ruler is marked in centimetres, with long marks at 0 cm, 10 cm, 20 cm, 30 cm, and so on. Measure the length of the line. Let’s say it is about 87 cm long. Hold the board ruler next to the line and say to the class: “Is the end of the line closer to 80 cm or is it closer to 90 cm? This line, *to the nearest 10 cm*, is 90 cm long.”

Let’s say you drew a different line, 92 cm long. Hold the ruler next to the line and say to the class: “Is the end closer to 90 cm or is it closer to 100 cm? This line, *to the nearest 10 cm*, is 90 cm long.”

Now what if you drew another line, 95 cm long? 95 is halfway between 90 and 100. Explain that we now use the rule that if the measurement is halfway between two main marks on the scale, we round up to the next highest mark. So, in this example, we round 95 cm up to 100 cm. That is like rounding 95 cm up to one whole metre.

Next you can use the tinted passage to motivate and to explain rounding off. You can also show these numbers on a number line or measuring tape so that learners can actually see which multiple the number is closer to.

Rounding off to the nearest 5 is new in Grade 5. You may need to spend some time explaining this.

Teachers sometimes teach a procedure which involves underlining the power you are rounding off to, and circling the digit that follows. This does *not* help learners to understand the meaning of rounding off. It also becomes confusing when learners need to start rounding off to the nearest 5. It may make more sense if you encourage learners to think of “the nearest multiple to”.

4.4 Rounding off with units of measurement

When a length is given in a smaller unit, we often round it off to a bigger unit.

If you round off to the nearest 100 cm, it is the same as rounding off to the nearest metre. Rounding off to the nearest 10 mm is the same as rounding off to the nearest centimetre, rounding off to the nearest 1 000 m is the same as rounding to the nearest kilometre and so on.

So, 46 mm rounded off to the nearest centimetre is 5 cm. This is because there are 10 mm in 1 cm, and 46 mm is closer to 50 mm than to 40 mm.

2 592 m rounded to the nearest kilometre is 3 km. There are 1 000 m in 1 km, and 2 592 m is closer to 3 000 m than 2 000 m.

We can also round off to other numbers, for example to the number 5. The number 5 and its multiples then become your base:

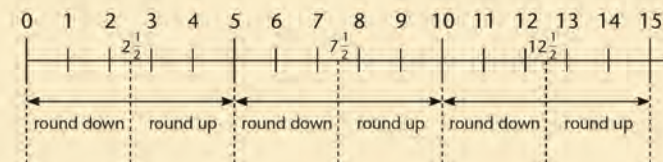

Rounded off to the nearest 5:

8 becomes 10	22 becomes 20
84 becomes 85	87 becomes 85
6 becomes 5	7 becomes 5
999 becomes 1 000	997 becomes 995
1 844 becomes 1 845	2 702 becomes 2 700
2 708 becomes 2 710	2 073 becomes 2 075

Notes on questions

Some of the sub-questions (b, d, e, f, h, i, j) in question 1 require learners to convert between units, or at least to have a sound understanding of the relationship between metric units of length.

Question 2 focuses on rounding to the nearest 5. This is new in Grade 5.

Answers

- (a) 20 cm (b) 100 cm (c) 7 700 km (d) 25 m
(e) 2 km (f) 3 cm (g) 10 km (h) 10 m
(i) 56 m (j) 2 m
- (a) 15 km (b) 45 cm (c) 55 cm (d) 300 km
(e) 25 mm (f) 90 cm (g) 600 mm (h) 15 m
(i) 510 m (j) 20 km
- (a) 1 750 km (b) 1 100 km (c) 363 100 km; 405 700 km

- Round the following lengths up or down as required.
 - 16 cm to the nearest 10 cm
 - 983 mm to the nearest cm
 - 7 665 km to the nearest 100 km
 - 2 519 cm to the nearest m
 - 1 500 m to the nearest km
 - 28 mm to the nearest cm
 - 9 km to the nearest 10 km
 - 999 cm to the nearest m
 - 5 569 cm to the nearest m
 - 2 099 mm to the nearest m
- Round off to the nearest 5 of the given unit.
 - 16 km (b) 44 cm
 - 57 cm (d) 302 km
 - 25 mm (f) 89 cm
 - 599 mm (h) 14 m
 - 509 m (j) 19 km
- The distance between Cape Town and Durban is given as 1 753 km. Round it off to the nearest 10 km.
 - The distance between Cape Town and East London is given as 1 079 km. Round it off to the nearest 100 km.
 - The distance from the Earth to the moon is not the same everywhere. This is because of the shape of the orbit of the Earth around the Sun. The shortest distance is given as 363 104 km. The longest distance is given as 405 696 km. Round off both of these distances to the nearest 100 km.

4.5 Problem solving

Mathematical notes

In these problems learners will use converting between units, rounding off, addition, subtraction, multiplication, division, and ratio.

Answers

- 184 km and 3 m
 - 39 km and 501 m
 - Sum of all the rounded distances: 184 km, so the difference is 3 m
 - 66 km and 500 m
- Snail covers $746 \text{ cm} = 7 \text{ m and } 46 \text{ cm}$
Sparrow covers $746 \text{ cm} \times 5 = 3\,730 \text{ cm} = 37 \text{ m and } 30 \text{ cm}$
Hen covers $3\,730 \text{ cm} \times 2 = 7\,460 \text{ cm} = 74 \text{ m and } 60 \text{ cm}$
Scottish Terrier covers $746 \text{ cm} \times 36 = 26\,856 \text{ cm} = 268 \text{ m and } 56 \text{ cm}$
 - 7 m and 46 cm; 37 m and 30 cm; 74 m and 60 cm; 268 m and 56 cm
 - 7 460 mm
 - 156 m and 66 cm or 15 666 cm
 - $38\,792 \text{ cm} = 387 \text{ m and } 92 \text{ cm}$

4.5 Problem solving

- Researchers fitted a tracking collar around a leopard's neck to find out how big his hunting ground is. In the first week, the leopard covered a distance of 42 km and 499 m. In the second week, his distance was 59 km and 504 m, and in the third week, 82 km.
 - How far did the leopard walk in these three weeks? Give your answer in km and m.
 - What is the difference between the longest and shortest distance that the leopard walked?
 - Round off all the distances to the nearest kilometre and add them together. What is the difference between this answer and the answer you gave in (a)?
 - If the leopard walked 931 km altogether in 14 days, how many kilometres does he walk on average per day? Give your answer in km and m.
- The yard animals are holding an endurance competition to see who can cover the biggest distance in one hour. Snail starts and covers 746 cm. Sparrow (he is not allowed to fly) has the shortest legs and moves five times further than Snail. Hen does double the distance of Sparrow and Scottish Terrier travels 36 times farther than Snail.
 - Write down the distance that each of the animals travelled. Write your answer in cm, and in m and cm.
 - Arrange the distances in ascending order (from shortest to longest).
 - Write the distance that Snail moved in mm.
 - How far will Snail go in three weeks if he moves one hour a day?
 - What distance did all the animals together travel in one hour? Answer in cm, and in m and cm.



Answers

2. (f) Snail: 745 cm; Sparrow: 3 730 cm; Hen: 7 460 cm; Scottish Terrier: 26 855 cm
 (g) 1 492 cm = 14 m and 92 cm

Notes on questions

In question 5, it is important that learners do the drawings. This will allow them to see that Nandi can plant at the start of a row and at the end of a row. If she plants tomatoes at the start and end of the row she can plant 7 tomato plants and 11 mealie seeds. If learners translate (b) into a number sentence, they will get $300 \text{ cm} \div 50 \text{ cm} = 6$, i.e. 6 tomatoes, and if they translate (c) into a number sentence, they will get $300 \text{ cm} \div 30 \text{ cm} = 10$, i.e. 10 mealie seeds.

Answers

3. (a) 6 000 m (b) 7,5 km
 4. (a) $5 \times 100 \text{ m} = 500 \text{ m}$ (b) 100 m too few
 5. (a) Learners' drawings might look something like this:

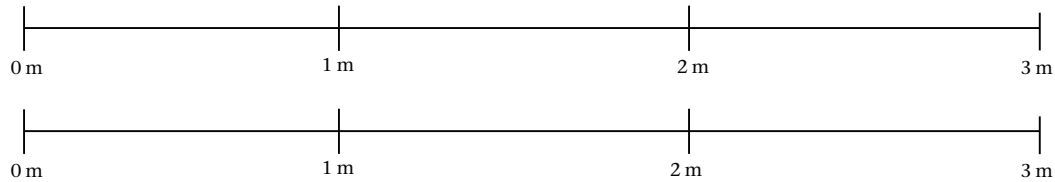

(b) 7 tomato plants. (Learners are *not* expected to show the measurements.)

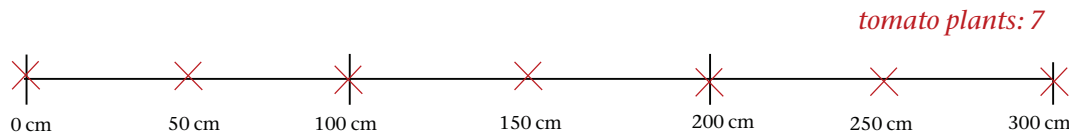

(c) 11 mealie seeds. (Learners are *not* expected to show the measurements.)

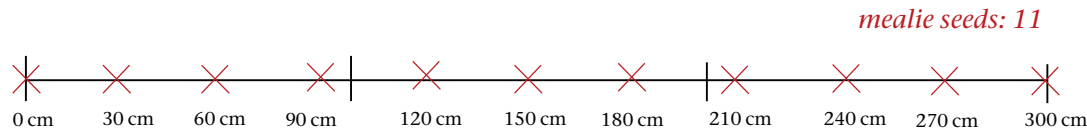

- (d) 4 rows (e) 88 mealie seeds (f) 70 tomato plants

- (f) Round off the distance each animal travelled in the one hour to the nearest 5 cm.
 (g) How far must Sparrow go if he wants to double Snail's distance?

3. For each 1 500 m that Mrs Cat runs, Mr Dog runs 2 000 m.
 (a) How far does Mr Dog run if Mrs Cat runs 4 500 m?
 (b) How far does Mrs Cat run if Mr Dog runs 10 km?
4. Adam wants to put up an electric fence consisting of five wires around his yard. He needs 5 lengths of 120 m wire. He decides to round off the length of the wire to the nearest 100 to make it easier to work out how much wire he will need.
 (a) How many metres of wire does he need if he works it out like this?
 (b) How many metres too many or too few is this?
5. Nandi plants vegetables in her vegetable patch. Each row is 3 m long. There are several rows.
 (a) Draw two rows each 12 cm long and divide each row into 3 equal parts. Each of the parts represents 1 m.
 (b) In the first row, Nandi plants her tomatoes 50 cm apart. Make marks on your drawing to show where the tomato plants will go. How many can she plant in this row?
 (c) In the next row, she plants mealies 30 cm apart. Make marks on your drawing to show where the mealie seeds will go. How many mealie seeds will she plant in this row?
 (d) She plants more rows of tomatoes, also 50 cm apart. If she has 28 tomato plants, how many rows of tomatoes can she plant?
 (e) For every 7 tomato plants that she plants, she plants 11 mealie seeds. How many mealie seeds will she plant if she plants 56 tomato plants?
 (f) How many tomato plants does she need if she plants 110 mealie seeds?

Answers

5. (g) two thirds
(h) two thirds
6. (a) $37 \text{ mm} + 33 \text{ mm} = 70 \text{ mm}$ (b) $87 \text{ cm} + 13 \text{ cm} = 1 \text{ m}$
(c) $155 \text{ m} - 35 \text{ m} = 120 \text{ m}$ (d) $880 \text{ mm} + 20 \text{ mm} = 90 \text{ cm}$
(e) $7\,500 \text{ m} + 500 \text{ m} = 8 \text{ km}$ (f) $6\,402 \text{ m} + 3\,598 \text{ m} = 10 \text{ km}$
(g) $11\frac{1}{2} \text{ km} - 2\frac{1}{2} \text{ km} = 9\,000 \text{ m}$ (h) $1\,554 \text{ cm} + 46 \text{ cm} = 16 \text{ m}$

(g) In one row she plants only 3 tomato plants. Which fraction/part of the 3 m long row is still open?

(h) What fraction of the row did she plant if she planted 5 tomato plants?

6. Fill in the sign of operation (+ or -) and the missing length to get the given length.

Example: $26 \text{ m} \oplus 24 \text{ m} = 50 \text{ m}$

- (a) $37 \text{ mm} \square \text{ ______} = 70 \text{ mm}$ (b) $87 \text{ cm} \square \text{ ______} = 1 \text{ m}$
(c) $155 \text{ m} \square \text{ ______} = 120 \text{ m}$ (d) $880 \text{ mm} \square \text{ ______} = 90 \text{ cm}$
(e) $7\,500 \text{ m} \square \text{ ______} = 8 \text{ km}$ (f) $6\,402 \text{ m} \square \text{ ______} = 10 \text{ km}$
(g) $11\frac{1}{2} \text{ km} \square \text{ ______} = 9\,000 \text{ m}$ (h) $1\,554 \text{ cm} \square \text{ ______} = 16 \text{ m}$

Learner Book Overview		
Sections in this unit	Content	Pages in Learner Book
5.1 Refresh your multiplication memory	Mental Mathematics	157 to 158
5.2 Working with hundreds	Mental Mathematics	159 to 160
5.3 Multiply 3-digit numbers by 1-digit numbers	The break down and build up method and word problems	161
5.4 Multiply 3-digit numbers by 2-digit numbers	The break down and build up method and word problems	162 to 163
5.5 Rate	Introduction of the concept of rate	163 to 165
5.6 Ratio	Ratio as a comparison between two rates	165 to 166

CAPS time allocation	7 hours
CAPS page references	13 to 15 and 166

Mathematical background

Multiplication and division are applicable in the following two kinds of situations:

- **Additive situations**, in which a whole quantity can be considered as being made up of equal parts.

Example: A consignment of sugar is packaged into a number of packets of equal mass.

Situations like this can be described with a number sentence of the form:

number of parts \times size of each part = total quantity, or

number of parts \times value of each part = total value.

The “value of each part” is sometimes called the **rate**.

The number of parts can be a whole number or a fraction.

- **Multiplicative situations**, in which one quantity can be considered as an enlargement (“stretching”) or reduction (“shrinking”) of another situation.

Example: A scale drawing of a building.

Situations like this can be described with a number sentence of the form:

size of one object \times scale factor (**ratio**) = size of another object

Possible questions

- 430 packets of sugar each have a mass of 400 g.
How much sugar is this in total? (430×400)
- 1 200 kg sugar is packaged in packets of 400 g each.
How many packets is this? ($1\ 200 \div 400$, *grouping*)
- 1 200 kg of sugar is packed into 400 equal packets.
How much sugar is in each packet? ($1\ 200 \div 400$, *sharing*)
- A house is 20 times as high as the drawing of the house on a building plan.
 - How high is the house if the drawing is 9 cm high? (20×9)
 - How high is the drawing if the house is 240 cm high? ($240 \div 20$)
- The height of a drawing of a house is 15 cm and the actual house is 240 cm high. How much larger than the drawing is the house? (The house is $240 \div 15 = 16$ times larger than the drawing.)

5.1 Refresh your multiplication memory

Teaching guidelines

Explain to learners that question 1 provides them with an opportunity to assess their knowledge of multiplication facts in the domain:

1-digit number \times multiple of 10.

More specifically, question 1 provides learners with an opportunity to identify which multiplication facts in the above domain they cannot easily produce. They should write these facts down so that they can work on them later.

You can save classroom time by making copies of page 419 of the Addendum, so that learners can fill in the answers they know immediately and simply skip those questions for which they cannot produce the answer quickly.

Answers

$30 \times 8 = 240$	$30 \times 10 = 300$	$30 \times 2 = 60$	$30 \times 5 = 150$	
$70 \times 7 = 490$	$70 \times 8 = 560$	$70 \times 10 = 700$	$70 \times 2 = 140$	
$80 \times 6 = 480$	$80 \times 7 = 560$	$80 \times 8 = 640$	$80 \times 10 = 800$	
$50 \times 4 = 200$	$50 \times 6 = 300$	$50 \times 7 = 350$	$50 \times 8 = 400$	
$20 \times 9 = 180$	$20 \times 4 = 80$	$20 \times 6 = 120$	$20 \times 7 = 140$	
$90 \times 3 = 270$	$90 \times 9 = 810$	$90 \times 4 = 360$	$90 \times 6 = 540$	
$60 \times 5 = 300$	$60 \times 3 = 180$	$60 \times 9 = 540$	$60 \times 4 = 240$	
$40 \times 2 = 80$	$40 \times 5 = 200$	$40 \times 3 = 120$	$40 \times 9 = 360$	
$10 \times 10 = 100$	$10 \times 2 = 20$	$10 \times 5 = 50$	$10 \times 3 = 30$	
$30 \times 3 = 90$	$30 \times 9 = 270$	$30 \times 4 = 120$	$30 \times 6 = 180$	$30 \times 7 = 210$
$70 \times 5 = 350$	$70 \times 3 = 210$	$70 \times 9 = 630$	$70 \times 4 = 280$	$70 \times 6 = 420$
$80 \times 2 = 160$	$80 \times 5 = 400$	$80 \times 3 = 240$	$80 \times 9 = 720$	$80 \times 4 = 320$
$50 \times 10 = 500$	$50 \times 2 = 100$	$50 \times 5 = 250$	$50 \times 3 = 150$	$50 \times 9 = 450$
$20 \times 8 = 160$	$20 \times 10 = 200$	$20 \times 2 = 40$	$20 \times 5 = 100$	$20 \times 3 = 60$
$90 \times 7 = 630$	$90 \times 8 = 720$	$90 \times 10 = 900$	$90 \times 2 = 180$	$90 \times 5 = 450$
$60 \times 6 = 360$	$60 \times 7 = 420$	$60 \times 8 = 480$	$60 \times 10 = 600$	$60 \times 2 = 120$
$40 \times 4 = 160$	$40 \times 6 = 240$	$40 \times 7 = 280$	$40 \times 8 = 320$	$40 \times 10 = 400$
$10 \times 9 = 90$	$10 \times 4 = 40$	$10 \times 6 = 60$	$10 \times 7 = 70$	$10 \times 8 = 80$

UNIT

5

WHOLE NUMBERS:

MULTIPLICATION

5.1 Refresh your multiplication memory

- For which of these do you know the answer? Copy the questions that you *do not* quickly know the answers to into your book, so that you can work on them later.

30×8	30×10	30×2	30×5	
70×7	70×8	70×10	70×2	
80×6	80×7	80×8	80×10	
50×4	50×6	50×7	50×8	
20×9	20×4	20×6	20×7	
90×3	90×9	90×4	90×6	
60×5	60×3	60×9	60×4	
40×2	40×5	40×3	40×9	
10×10	10×2	10×5	10×3	
30×3	30×9	30×4	30×6	30×7
70×5	70×3	70×9	70×4	70×6
80×2	80×5	80×3	80×9	80×4
50×10	50×2	50×5	50×3	50×9
20×8	20×10	20×2	20×5	20×3
90×7	90×8	90×10	90×2	90×5
60×6	60×7	60×8	60×10	60×2
40×4	40×6	40×7	40×8	40×10
10×9	10×4	10×6	10×7	10×8

Critical knowledge and skills

Without fluency in the production of multiplication facts for 1-digit numbers and multiples of 10, 100 and 1 000, learners cannot do multiplication with multi-digit whole numbers fast and accurately enough to be of any value.

Teaching guidelines

Fluency in the production of basic number facts depends on memorising at least some facts, and the ability to quickly produce non-remembered facts from known facts. Explain this to learners. To save classroom time, you can photocopy the table provided on page 420 of the Addendum.

Demonstrate how new facts can be formed from known facts. Use the example in the tinted passage and other examples of your own choice.

Answers

- Learners work out the answers to the questions they listed (or skipped) in question 1.
- Learners copy only their answers from question 2 into the given table.

×	2	4	8	3	6	5	10	9	7
10	20	40	80	30	60	50	100	90	70
50	100	200	400	150	300	250	500	450	350
90	180	360	720	270	540	450	900	810	630
80	160	320	640	240	480	400	800	720	560
40	80	160	320	120	240	200	400	360	280
20	40	80	160	60	120	100	200	180	140
30	60	120	240	90	180	150	300	270	210
60	120	240	480	180	360	300	600	540	420
70	140	280	560	210	420	350	700	630	490

Jeminah does not immediately know how much 60×7 is.

She asks herself: "Is there some other multiplication fact for 60 that I do know?"

She can only remember that $2 \times 60 = 120$.

Now she thinks: "If $2 \times 60 = 120$, then 4×60 is 120 doubled... and that is 240.

And $6 \times 60 = 4 \times 60 + 2 \times 60 = 240 + 120 = 360$.

So 7×60 is one 60 more than 360, and that is 420."

- Choose any of the items you could not immediately answer when you did question 1. Try to work it out using any method you prefer.
 - Do the same for another item you could not answer. Continue in this way until you have answered all those items.
- Copy the table below, and fill in the answers that you did *not* know when you did question 1.

×	2	4	8	3	6	5	10	9	7
10									
50									
90									
80									
40									
20									
30									
60									
70									

5.2 Working with hundreds

Teaching guidelines

The purpose of this section is to develop fluency in the production of multiplication facts for multiples of 10 and 100. While the trick of counting zeros, for example finding 30×40 by adding two zeros to the answer 12 for 3×4 is useful, it is important that learners also understand the multiplication facts for multiples of 10 and 100.

The questions are designed to provide learners with opportunities to develop such understanding.

Answers

- (a) 24 (b) 240
- Double 600 \rightarrow 1 200 and double again \rightarrow 2 400
Mlungisi is right.
- 2 400
- (a) 600 (b) 40
- Both give the same answer: 2 400.
- 24 000

5.2 Working with hundreds

1. How much is each of the following?

(a) 4×6

(b) 4×60

Mlungisi says when he looks at his answers for question 1, he can see that he just needs to write another 0 after 240 to get the answer for 4×600 .

So Mlungisi believes that $4 \times 600 = 2\ 400$.

- Double 600, and double again, to check whether Mlungisi is right.
- How many beads are shown below?

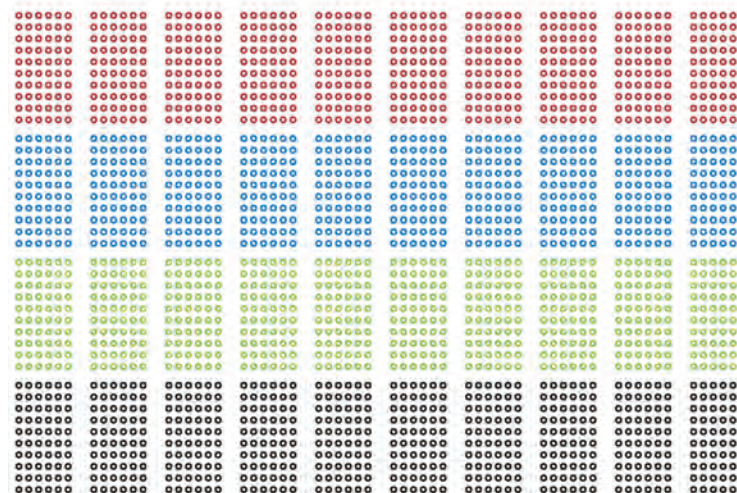

- How many beads of each colour are there?
 - How many groups of 60 beads each are there?
- Are there 4×600 beads or 40×60 beads?
- How many beads will there be on 10 pages like this?

Teaching guidelines

Questions 7 and 8 are intended to help learners to form a sense of the magnitude of multiples of 10, 100, 1 000, 10 000 and 100 000, and how they relate to each other. To promote quality of engagement with the questions, you could make a drawing for question 7(a) on the board and ask learners to suggest how you should change the drawing so that it represents question 7(b), and question 7(c):



If learners are challenged by question 8, you may suggest that they write parts of the statements in symbols, for example question 8(b):

10 10 10 10 10 10 10 10 10 10

Such a representation may provide support for learners' thinking about the meaning of the statement, for example:

10 10 10 10 10 10 10 10 10 10

ten tens = one hundred

ten tens = one hundred, etc.

Answers

7. (a) 100 (b) 1 000 (c) 10 000
 (d) 300 (e) 700 (f) 7 000
8. (a) True (b) False (c) True
 (d) True (e) True (f) True
9. $100 \times 583 = 100 \times 500 + 100 \times 80 + 100 \times 3 = 50\,000 + 8\,000 + 300$
10. $100 \times 6 = 600$ $100 \times 60 = 6\,000$ $200 \times 60 = 12\,000$
 $400 \times 60 = 24\,000$ $60 \times 300 = 18\,000$ $30 \times 600 = 18\,000$
 $50 \times 700 = 35\,000$ $400 \times 80 = 32\,000$ $900 \times 4 = 3\,600$
 $40 \times 900 = 36\,000$ $70 \times 900 = 63\,000$ $8 \times 700 = 5\,600$
 $600 \times 70 = 42\,000$ $30 \times 900 = 27\,000$ $700 \times 40 = 28\,000$

7. (a) How many people are ten groups of 10 people each?
 (b) How many people are ten groups of 100 people each?
 (c) How many people are ten groups of 1 000 people each?
 (d) How many people are ten groups of 30 people each?
 (e) How many people are ten groups of 70 people each?
 (f) How many people are ten groups of 700 people each?
8. In each case, indicate whether the statement is true or false.
 (a) Ten hundreds are one thousand.
 (b) Hundred tens are ten thousand.
 (c) Hundred hundreds are ten thousand.
 (d) Hundred tens are one thousand.
 (e) Two hundred fives are one thousand.
 (f) Two hundred fifties are ten thousand.

Now look at this:

$$367 = 300 + 60 + 7$$

$$10 \times 367 = 10 \times 300 + 10 \times 60 + 10 \times 7$$

$$= 3\,000 + 600 + 70$$

When 367 is multiplied by 10 the 300 becomes 3 000, the 60 becomes 600 and the 7 becomes 70.

9. Investigate how the 500, 80 and 3 that make up 583 are affected if 583 is multiplied by 100.
10. How much is each of the following?
- | | | |
|-----------------|-----------------|-----------------|
| 100×6 | 100×60 | 200×60 |
| 400×60 | 60×300 | 30×600 |
| 50×700 | 400×80 | 900×4 |
| 40×900 | 70×900 | 8×700 |
| 600×70 | 30×900 | 700×40 |

5.3 Multiply 3-digit numbers by 1-digit numbers

Teaching guidelines

Do the example in the tinted passage on the board, and possibly one or two more. Emphasise the strategy of replacing the single “difficult” product (347×8) with the sum of three “easy products” (300×8 , 40×8 and 7×8).

Notes on questions

Learners may find question 5 demanding. The question is deliberately designed to provide learners with the challenge to interpret the different numbers given.

At each feeding session the 8 goats together will get 8×375 ml, that is 3 000 ml or 3 ℓ. Hence Jane needs $4 \times 3 \ell = 12 \ell$ every day.

Some learners may argue like this and will have to calculate the product of a 2-digit and a 3-digit number:

Feeding 8 goats four times a day is $4 \times 8 = 32$ feeds at 375 ml per feed, which is 32×375 ml.

If such learners are challenged by the multiplication, you can suggest to them that they first calculate how much milk is needed for one feeding session for 8 goats.

Answers

1. (a) 3 941 (b) 2 268
 (c) 3 258 (d) 4 984
 (e) 2 442 (f) 4 710
 (g) 2 556 (h) 3 451
 (i) 4 696 (j) 2 792
 (k) 3 346 (l) 7 264
2. 1 666 rooms
3. 1 248 guests
4. 5 193 water sachets
5. 12 ℓ
6. R1 251
7. 7 kg

5.3 Multiply 3-digit numbers by 1-digit numbers

347×8 can be calculated as follows:

$$347 = 300 + 40 + 7$$

$$\begin{aligned} \text{So, } 347 \times 8 &= 300 \times 8 + 40 \times 8 + 7 \times 8 \\ &= 2\,400 + 320 + 56 \\ &= 2\,000 + 400 + 300 + 20 + 50 + 6 \\ &= 2\,776 \end{aligned}$$

1. Calculate each of the following.
(a) 563×7 (b) 6×378
(c) 362×9 (d) 8×623
(e) 6×407 (f) 785×6
(g) 9×284 (h) 7×493
(i) 587×8 (j) 698×4
(k) 478×7 (l) 908×8
2. One hotel has 238 rooms. How many rooms are there in 7 such hotels?
3. At a large wedding reception, 8 guests sit at one table. How many guests are at the wedding reception if 156 tables are fully occupied?
4. During a cross-country marathon there should be at least nine water sachets for each athlete. How many sachets of water are needed if there are 577 runners?
5. Jane needs to feed eight two-week-old baby goats 375 ml of milk each, four times a day. How much milk does she need every day? Give your answer in litres.
6. The price of four soccer balls is R556. How much do nine balls cost?
7. A bag of onions has a mass of 875 g. Calculate the total mass of eight bags of onions. Give your answer in kilograms.

5.4 Multiply 3-digit numbers by 2-digit numbers

Teaching guidelines

Learners have already multiplied a 2-digit number by a 3-digit number in Term 1. It should suffice to demonstrate one or two cases, for example 67×547 and 56×884 , on the board before allowing learners to engage with question 1 and proceed to the other questions.

Notes on questions

To do question 4 quickly, one needs to observe that 177 is half of 354. It is unlikely that all learners in a class will notice this by themselves. After giving learners some time to work on question 4, you may ask them what half of 354 is, and suggest that if they know this the question will become easy.

Answers

- $300 \times 80 + 40 \times 80 + 7 \times 80 + 300 \times 4 + 40 \times 4 + 7 \times 4$
 $= 24\,000 + 3\,200 + 560 + 1\,200 + 160 + 28$
 $= 29\,148$
- $80 \times 300 + 80 \times 40 + 80 \times 7 + 4 \times 300 + 4 \times 40 + 4 \times 7$
 $= 24\,000 + 3\,200 + 560 + 1\,200 + 160 + 28$
 $= 29\,148$
- (a) 29 184 (b) 20 992
(c) 15 708 (d) 23 464
(e) 32 121 (f) 21 252
(g) 45 402 (h) 18 434
(i) 18 408 (j) 34 146
(k) 16 704 (l) 22 816
- 177 is half of 354, therefore the answer must be half of $18\,408 = 9\,204$ kg
- R29 296
- 6 096 light bulbs
- (a) 18 564 strawberry plants
(b) 22 320 jars

5.4 Multiply 3-digit numbers by 2-digit numbers

347×84 can be calculated as follows:

$$347 = 300 + 40 + 7$$

So, $347 \times 84 = 300 \times 84 + 40 \times 84 + 7 \times 84$

$$= 300 \times 80 + 40 \times 80 + 7 \times 80 + 300 \times 4 + 40 \times 4 + 7 \times 4$$

Each of the three parts have to be calculated separately.

- Calculate each of the parts of 347×84 shown above, and then find out how much 347×84 is.
- Calculate 347×84 in a different way, by first breaking down 84 into 80 and 4.
- Calculate each of the following.

(a) 384×76	(b) 64×328
(c) 374×42	(d) 419×56
(e) 83×387	(f) 276×77
(g) 658×69	(h) 709×26
(i) 52×354	(j) 542×63
(k) 288×58	(l) 46×496
- See if you can use your answer for question 3(i) to calculate the mass of 177 bags of river sand if the mass of one bag is 52 kg.
- The entrance fee for a concert is R32 for school children and R48 for adults. Tickets are sold at the door. How much money is taken at the door if 215 children and 467 adults attend the concert?
- Twenty-four schools each receive a large box with 254 light bulbs. How many light bulbs is this in total?
- (a) On a strawberry farm, there are 546 strawberry plants in each bed. How many plants are there altogether in 34 strawberry beds?
(b) Strawberry jam is also produced on the farm and packed in boxes of 48 jars each. How many jars are there in 465 boxes?

Answers

8. (a) 576 balls (b) R7 488

5.5 Rate

Mathematical notes

A rate describes how much of one quantity (e.g. money) corresponds to one unit of another quantity (e.g. volume of petrol): R10,40 may correspond to 1 ℓ of petrol. Other examples of rates are speed (the distance that corresponds to a unit of time), dosages (amount of medicine that corresponds to a unit of body mass), tax (amount of tax that corresponds to R1 000 of income) and sound pitch (number of vibrations that correspond to a unit of time).

Any rate situation can be represented by a number sentence of the form

$$\text{amount} \times \text{rate} = \text{total}$$

For example, if a recipe requires 5 g of salt for every kg of beans, the number sentence is

$$\text{mass of beans in kg} \times 5 = \text{mass of salt in g}$$

In the case of cost rates, the number sentence can be stated as

$$\text{amount} \times \text{unit cost} = \text{total cost}$$

In the case of speed, the number sentence can be stated as

$$\text{duration of time} \times \text{speed} = \text{distance covered}$$

Possible misconceptions

Learners may easily form the misconception that a rate is always constant. This may inhibit them from engaging successfully with situations that involve variable rates, which becomes important in higher grades. The drum play situation used as an introductory context here, and question 2 on the next page, are specifically designed to alert them to variable rates at an early stage.

Teaching guidelines

Ask learners to comment on the difference between Salmon and Rashid's drum playing once they have finished completing the table in question 2. You may introduce the term "changing rate" or "variable rate" to distinguish Rashid's playing from Salmon's playing.

Answers

1. 18 beats

8. A container with three tennis balls costs R39. The tennis coach needs at least twelve new tennis balls per match. This season, 48 matches will be played.

- (a) How many tennis balls does the coach need this season?
(b) How much money will he need to buy the tennis balls?

5.5 Rate

Salmon and Rashid both play drum in an orchestra.

Salmon plays a big drum and Rashid plays a small drum.

For a certain item that lasts more than four minutes, Salmon has to beat the big drum at 10-second intervals.

Rashid has to start slowly but play faster and faster while they perform the item.



1. How many beats should Salmon make in 3 minutes while they perform the item?

This table shows how many beats each player made during each minute while they played the item.

	First minute	Second minute	Third minute	Fourth minute
Salmon				
Rashid				

Notes on questions

The first three parts of question 4 demonstrate three different kinds of questions that can be asked with respect to a situation that involves a constant rate.

In question 4(a) the rate and the duration of time are given, and the total number of beats has to be calculated: $5 \times 8 = \text{total number of beats}$

In question 4(b) the duration of time and the total number of beats are given, and the rate has to be calculated: $3 \times \text{rate} = 36 \text{ beats}$

In question 4(c) the rate and the total number of beats are given, and the duration of time has to be calculated: $\text{duration of time} \times 8 = 32 \text{ beats}$

Teaching guidelines

To help learners who are challenged by questions 4(b) and 4(c), you may suggest that they clarify to themselves what is known and what is unknown in each of questions 4(a), (b) and (c). They may make and complete a table like this before attempting to answer questions (b) and (c):

	Play time	Rate	Number of beats
Question 4(a)	5 minutes	8 beats per minute	unknown
Question 4(b)			
Question 4(c)			

Once learners have completed question 4, you may show them how the different questions can be represented by number sentences as shown above. Resist the temptation to show the number sentences before learners have engaged with the questions intensively. Seeing the number sentences may deny them the opportunity to learn to interpret verbal descriptions of situations.

Answers

2.

	First minute	Second minute	Third minute	Fourth minute
Salmon	6	6	6	6
Rashid	14	19	26	32

3. No

4. (a) 40 beats (b) At a rate of 12 beats per minute

(c) 4 minutes (d) 60 beats

5. (a) 222 tomatoes (b) 400 tomatoes

2. Copy the table below. Count the dots in each cell of the table on page 163 and enter the numbers in your table.

	First minute	Second minute	Third minute	Fourth minute
Salmon				
Rashid				

Salmon beat his drum at a rate of 6 beats per minute during the whole item.

We can say Salmon played at a **constant rate** of 6 beats **per** minute, for 4 minutes.

When we say something is **constant**, we mean it remains the same, it does not change.

3. Did Rashid also play at a *constant* rate during the 4 minutes?

4. (a) In another item, Rashid plays at a constant rate of 8 beats per minute and he plays for 5 minutes. How many beats does he make in total?

(b) In this item Salmon also plays at a constant rate, but he only plays for 3 minutes. He makes 36 beats in total. At what rate does Salmon play?

(c) There is a third drummer in this item. Maria plays at a constant rate of 8 beats per minute, and she makes 32 beats in total. For how many minutes does she play?

(d) If Salmon continues to play as fast as he does in question (b), how many beats will he make in 5 minutes?

5. Eric, Sally and Katie are working on a tomato farm.

(a) Eric picks tomatoes at an almost constant rate of 74 tomatoes per hour. Approximately how many tomatoes will he pick in 3 hours?

(b) Sally also picks tomatoes at an almost constant rate. She picks 240 tomatoes in 3 hours. How many tomatoes will she pick in 5 hours?

Answers

5. (c) 6 hours

5.6 Ratio

Mathematical notes

Quantities can be compared in two ways:

- By stating the difference: how much more the one quantity is than the other, for example “Susan earns R24 000 more than William each month.”
- By stating the **ratio**: by what the one quantity must be multiplied to get the other quantity, for example “Susan earns 3 times as much as William each month.”

Both difference and ratio are used to compare two quantities of the same kind. Ratios appear in different kinds of situations, several of which are addressed in Term 4 Unit 5.

In this unit, the concept of ratio is introduced to compare two rates.

Teaching guidelines

Questions 1 to 7 provide learners with a variety of opportunities to compare two quantities, namely the different constant rates at which Salmon and Rashid beat their drums.

The term “ratio” is only introduced after learners have done these questions (i.e. on page 166 of the Learner Book).

Answers

3. At a rate of 30 beats per minute
4. (a) 150
(b) 30

- (c) Katie picks tomatoes at a rate of approximately 46 tomatoes per hour. On a certain day she picked 276 tomatoes in total. How many hours did she work?

5.6 Ratio

Salmon and Rashid are practising a new item. Salmon has to beat the big drum 6 times during each minute at regular intervals. Rashid has to make 30 beats on the small drum during each minute.

1. Tap with your fingers on your desk for a while, approximately as fast as Salmon has to play his drum. Now use your pencil to tap and make a mark on a sheet of paper each time you tap. Your teacher will let you do this for 4 minutes.



2. Now tap your desk for a while, approximately as fast as Rashid has to play his drum. Then use your pencil again and make a mark on another sheet of paper each time you tap. Your teacher will let you do this for 4 minutes.



We can say Salmon has to play at a **rate** of 6 beats **per** minute.

3. At what rate does Rashid have to play?
4. (a) How many beats should Rashid make in 5 minutes?
(b) How many beats should Salmon make in 5 minutes?

In order to answer question 4, you multiplied the rate by the period of time.

Teaching guidelines

Learners' comparison of the two drum-beating rates culminates in the completion of the table in question 6.

Once learners have completed question 7, you may put this question to the whole class: *“Does Rashid beat his drum five times as often as Salmon?”*

Reflection and discussion on this question should help learners to consolidate the idea of a fixed ratio between the two drum-beating rates.

Answers

5. (a) 90 times
(b) 24 times

6.

Number of beats on the small drum	30	60	90	120	150	180	210	240
Number of beats on the big drum	6	12	18	24	30	36	42	48

7. (a) 60 (b) 150 (c) 45 (d) 5
8. (a) The ratio of Isaac's steps to Benjamin's steps is 12 to 20 or 3 to 5.
(b) 10 steps
(c) 18 steps

5. (a) How many times should Rashid beat the small drum if Salmon beats the big drum 18 times?
(b) How many times should Salmon beat the big drum if Rashid beats the small drum 120 times?
6. (a) Copy this table, and enter your answers for question 5 in it.

Number of beats on the small drum								
Number of beats on the big drum	6	12	18	24	30	36	42	48

- (b) Complete the table.
7. (a) How many beats should be made on the small drum, for every 12 beats on the big drum?
(b) How many beats should be made on the small drum, for every 30 beats on the big drum?
(c) How many beats should be made on the small drum, for every 9 beats on the big drum?
(d) How many beats should be made on the small drum, for every 1 beat on the big drum?

To compare how often the two players must beat their drums, we can say that the **ratio** of beats on the small drum to beats on the big drum is 30 to 6. We can also say the ratio is 5 to 1.

The **ratio** is a comparison between two quantities of the same kind.

8. When he walks, Isaac takes 12 steps each minute while Benjamin takes 20 steps.
- (a) What is the ratio between the numbers of steps they take in one minute?
(b) How many steps will Benjamin take while Isaac takes 6 steps?
(c) How many steps will Isaac take while Benjamin takes 30 steps?

Learner Book Overview		
Sections in this unit	Content	Pages in Learner Book
6.1 Flat and curved surfaces on 3-D objects	An overview of the surfaces of 3-D objects	167 to 168
6.2 Make cylinders and cones	Make cylinders and cones out of paper and other materials	169 to 171
6.3 Make prisms and pyramids	Make prisms and pyramids out of paper and other materials	172 to 175

CAPS time allocation	6 hours
CAPS page references	22 and 167 to 168

Mathematical background

Cylinders and prisms are very similar. Any cylinder and any prism has two identical flat surfaces (faces) at the ends. A cylinder has only one other surface, which is curved, while all the other surfaces of a prism are flat – in fact, rectangles.

Cones and pyramids have a flat surface at one end (the base) and a pointed end (like a sharpened pencil) opposite the base. A cone has one curved surface between the flat (circular) base and the pointed end, while a pyramid has one flat triangular surface for each side of the polygonal base.

Resources

Many models and/or real-life examples of prisms, pyramids, cylinders and cones; paper, scissors and sticky tape

6.1 Flat and curved surfaces on 3-D objects

Teaching guidelines

If possible, provide many more examples of prisms, pyramids, cylinders and cones. The best way for learners to begin to distinguish properly between the four types of objects is to have as many as possible of these objects available, and to ask learners to group the objects into the four categories. Ensure that learners are able to justify their classification by referring to the key characteristics mentioned on the previous page of this Teacher Guide.

Possible misconceptions

Some learners may confuse the four kinds of objects because they are not yet distinct in their minds (this is due to inexperience, or to them not focusing on the important characteristics: pointedness or not, curved surfaces or polygonal faces). Beware that some learners may simply be confusing the names, for example saying pyramid when they mean prism.

UNIT

6

PROPERTIES OF THREE-DIMENSIONAL OBJECTS

6.1 Flat and curved surfaces on 3-D objects

Different kinds of 3-D objects have surfaces with different shapes.

Prisms and **pyramids** have **flat surfaces** only.



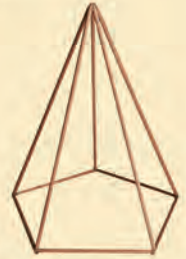

Wooden prisms



A frame for a pyramid

Spheres and egg-shaped objects have **curved surfaces** only.



Cylinders and **cones** have flat and curved surfaces.



A paper cone seen from different positions



A tin of beans has the shape of a cylinder.

Flat surfaces of 3-D objects are also called **faces**.

GRADE 5: MATHEMATICS [TERM 2]167

Teaching guidelines

Once learners have completed the questions individually and have written down their answers, let them compare their answers in small groups.

Answers

- Mountains photo: three cylindrical mountains with cone-shaped tops
 Windmill photo: triangular pyramid as the standing frame for the windmill, cylindrical dam
 Antlion trap photo: cone-shaped hole
 Hut photo: cylindrical building, cone-shaped roof
 Church photo: squared-based pyramidal tower roof
 Pipes photo: cylinder
- Learners' own work
- Learners' own work
- Probably yes, but the answer depends on the actual classroom.

Teaching guidelines

It is worthwhile to teach learners how to make a sketch of a cylinder as seen from an angle:

Step 1: Draw the circular edge of one end of the cylinder, as you would see it from the side.



Step 2: Draw two lines to show the "body" of the cylinder.

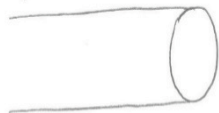

Step 3: Add what you can see of the edge at the other end of the cylinder.

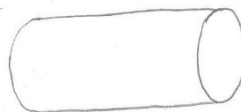

Alternatively, you can start by drawing two straight lines to show the body and then add curves to show the ends.

First

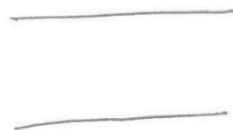

then



Similar steps can be followed to draw a prism with a rectangular base, or even a more complicated base like a hexagon.

- Describe all the cones, cylinders and pyramids you can see in these pictures.



- Describe any object with a curved surface in your classroom.
- Describe three prism-shaped objects in your classroom.
- Does your classroom have the shape of a prism?

6.2 Make cylinders and cones

Teaching guidelines

Allow learners as much time as possible to explore the characteristics of cones and cylinders. It is very important that the objects are not simply things-to-be-named, but rather objects with specific characteristics.

Demonstrate the rolling of a tube, then let learners roll their own tubes.

Learners may find it quite challenging to draw a sliced cylinder (question 3). Allow them to struggle on their own for at least 5 minutes; then provide support. Some learners may produce reasonable drawings like the one on the right.

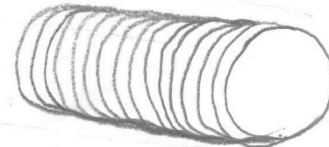

A better drawing of a sliced cylinder can be made by drawing separate short cylinders:



The cylindrical slices can be drawn closer together:

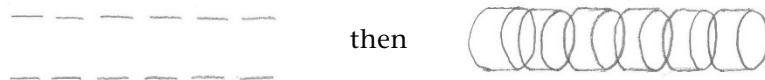

The curved surfaces can be shaded to give a better picture of the sliced cylinder:



Answers

- Learners' own practical work
- (a) Circular shape

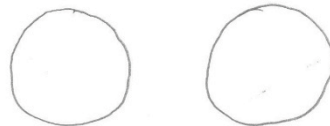

- (b) Yes, the two ends are the same.
- The slices will also be cylinders. See the drawings above.

6.2 Make cylinders and cones

- You can easily make a cylinder from a sheet of paper.



Do it.



An open cylinder like this can also be called a **tube**.

You can put sticky tape at two or three places to hold it together.

- The two ends of your cylinder are open.
 - Make a rough drawing to show the shape of the two open ends.
 - Are the two ends the same?

If you fill the cylinder with clay and close the two ends, and let the clay dry, you will have a **solid cylinder**.

If you slice a loaf of bread, you can make all the slices almost the same.

- If a cylinder is cut in the way you will slice a loaf of bread, what shape will the cylinder slices be? Make a drawing.



Teaching guidelines

It will definitely make it easier for learners if you first demonstrate question 4. However, it will be of great value if they can engage with the challenge of making sense of the photographs themselves, and manage to perform the actions demonstrated in the photographs. It is an opportunity to develop their graphical literacy.

Answers

4. Learners' own practical work

5. (a) No

(b) No

(c) Here are some things learners may mention:

The ends of cylinders are the same while the ends of cones differ.

A cylinder has two identical ends while a cone has one flat end and one pointed end.

The shape of a cylinder viewed from the side is rectangular while the shape of a cone viewed from the side is triangular.

You can think of a cylinder as many slices pressed together.

Each of the slices is also a cylinder.

A thin cylinder like this is also called a **circular disk**.

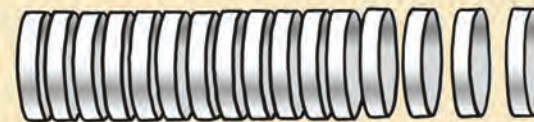

4. You can also make a cone by rolling a sheet of paper. Look at the pictures below and try to do the same. Use sticky tape to hold it together.

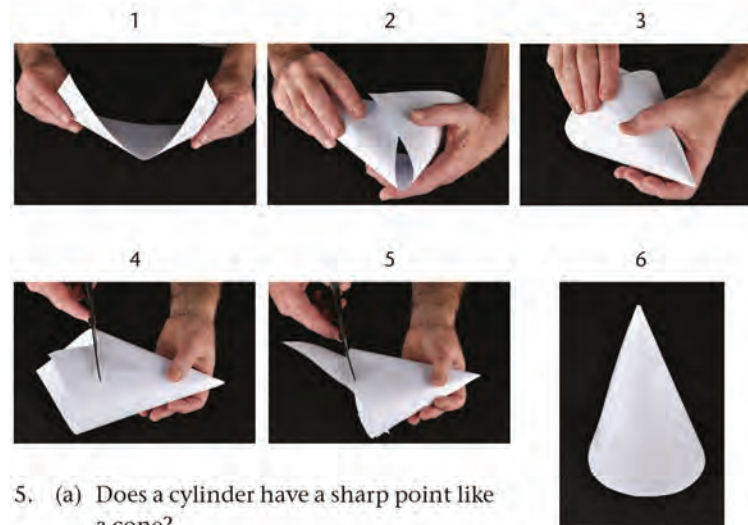

5. (a) Does a cylinder have a sharp point like a cone?

(b) Can a cone be cut into slices that are all the same, like you can do with a cylinder?

(c) Think of other differences between a cylinder and a cone and describe them.

Teaching guidelines

Explain to learners that the pictures in question 6 show a particular way in which cylinders and cones can be cut into smaller pieces. It is similar to the way in which a loaf of bread is normally cut into slices:



Mathematical notes

The “slices” of the cylinder (see question 6) are called *circular discs*. For the cone, each slice is called a *truncated cone*.

Question 7 is quite important because it challenges learners to explore the similarities and differences between the four kinds of objects. These similarities and differences arise when one thinks about the surfaces (curved or flat) between the ends, and the ends (one pointed end and one flat end, or two identical flat ends).

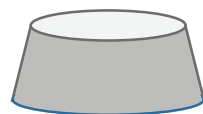

Truncated cone

Answers

- The slices of the cylinder are again cylinders, of equal width. Only one slice of a cone is a cone again, the other slices are not pointed at one end, and they have different widths.
- The end surfaces of prisms and cylinders are the same, but this is not true for the ends of cones and pyramids.
 - Prisms and pyramids have square, rectangular or triangular bases; cylinders and cones have circular bases.

Enrichment activity

Ask learners to make a truncated pyramid from paper.

6. Look at the pictures below. Can you describe another difference between a cylinder and a cone?

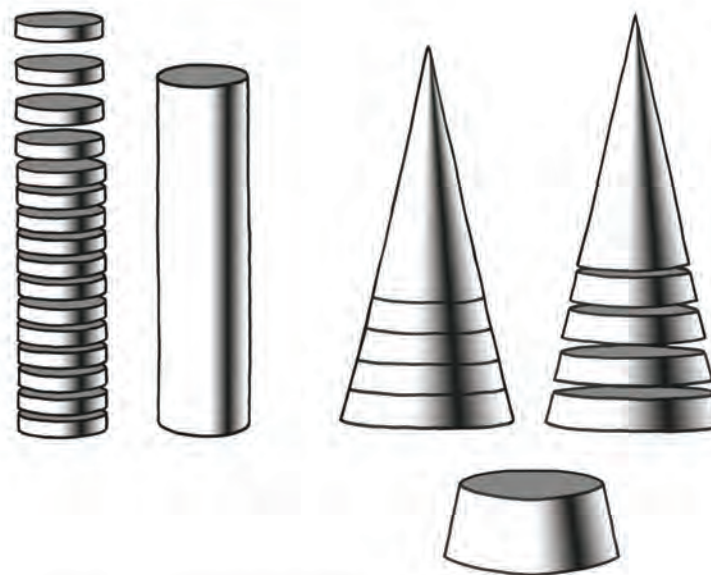

7. A prism and a pyramid are shown below.

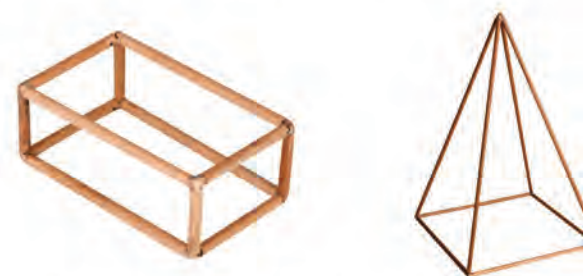

- How do prisms and cylinders differ from cones and pyramids?
- How do prisms and pyramids differ from cones and cylinders?

6.3 Make prisms and pyramids

Teaching guidelines

Again, allow learners as much time as possible to explore the characteristics of pyramids and prisms. Simply naming the different objects is not enough. Learners should be able to identify their specific characteristics.

The links between cylinders and prisms, and between cones and pyramids, should become apparent from the way learners are asked to fold cylinders into prisms, and cones into pyramids. The folding process changes the curved edges of the flat (open) ends of cones and cylinders into the polygonal ends of pyramids and prisms. Likewise, the curved surface of a cone or cylinder is folded into flat surfaces. These are triangles in the case of pyramids and rectangles in the case of prisms. Be sure to explore these links with your learners.

6.3 Make prisms and pyramids

The pictures show how you can fold a sheet of paper to make a prism.

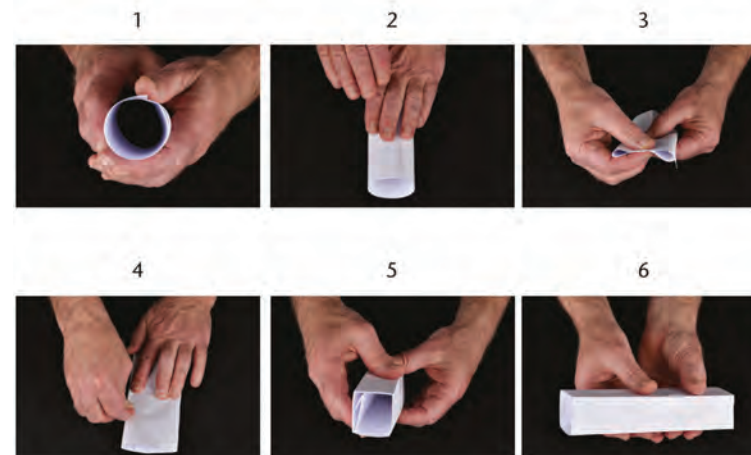

Picture 6 shows a **square prism**. It is open at the two ends.

Picture 7 shows a **hexagonal prism** and Picture 8 shows a **rectangular prism**.



Teaching guidelines

Questions 1 to 4 are designed to develop and refine the concept of the “face” of a 3-D object. It is important that you participate in the learners’ activities. When they have finished with question 1, explain to them that in the next activity (i.e. question 2) they will cut pieces of paper that can be used to close the open ends.

Answers

- (a) to (c) Learners’ own practical work
- Learners’ own work
- 4 rectangular pieces and 2 square pieces of paper
- (a) 5 faces
(b) 3 rectangular faces and 2 triangular faces

1. Make the following:

- (a) a triangular prism with open ends
- (b) a square prism with open ends
- (c) a pentagonal prism with open ends

You can cut two square-shaped pieces of paper to close the open ends of your square prism.

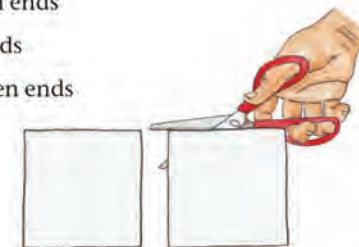

2. Make rough drawings to show the shapes of the endpieces that can be used to close your triangular and pentagonal prisms.

If you have a coloured rectangular piece of paper like the one shown on the right, you can paste it onto your square prism to make it look like this:

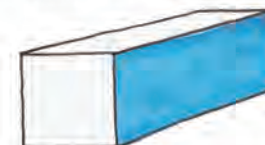

3. How many more rectangular pieces of coloured paper do you need, and how many square pieces of coloured paper do you need, so that all the outer parts of your square prism are coloured?

Each outer part of a prism for which you need a piece of coloured paper is called a **face** of the prism.

4. (a) How many faces does a triangular prism have?
(b) What are the shapes of the faces, and how many faces of each kind of shape does a triangular prism have?

A prism with six square faces is called a **cube**.



Teaching guidelines

Learners can do question 7 at home as a project.

Answers

5. (a) 7 faces
(b) 5 rectangular faces and 2 pentagonal faces
6. 6 rectangular faces and 2 hexagonal faces
7. Learners' own practical work

5. (a) How many faces does a pentagonal prism have?

(b) What are the shapes of the faces, and how many faces of each kind of shape does a pentagonal prism have?

A prism with ends like this is called a **hexagonal prism**.



6. What are the shapes of the faces, and how many faces of each kind of shape does a hexagonal prism have?

7. Make a square-based pyramid by working as shown in the pictures.

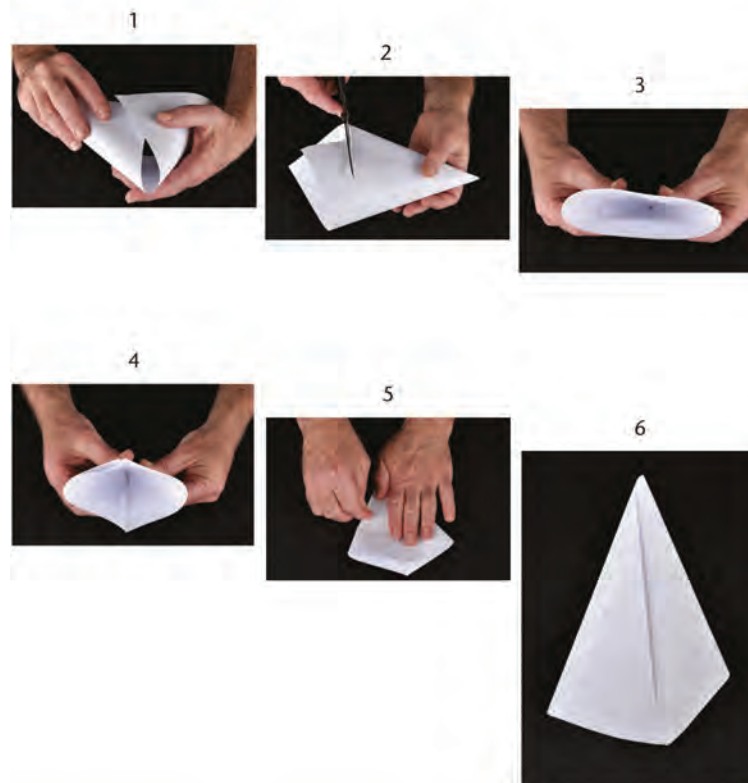

Answers

- 8. Learners' own drawings: 1 square and 4 triangles
- 9. (a) Pentagonal prism
- (b) Pentagonal pyramid
- (c) Triangular pyramid
- (d) Rectangular prism
- (e) Square prism or cube

8. Make rough drawings of the shapes of all the faces of your square-based pyramid.

These are pictures of the frames of a **square-based** pyramid and a **hexagonal** pyramid.

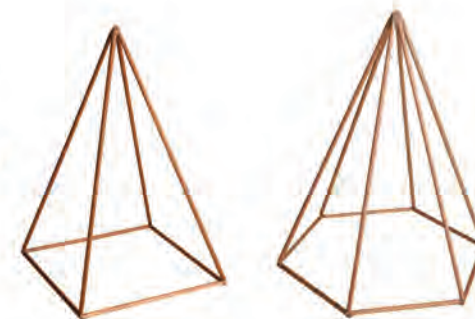

9. In each row below the shapes of all the faces of a 3-D object are shown. In each case name the object that has such faces.



Learner Book Overview		
Sections in this unit	Content	Pages in Learner Book
7.1 Making patterns	Revisiting the basics of clever counting	176
7.2 From pictures to tables	Generating, organising and generalising data	177
7.3 Extending patterns	From rules to tables	178
7.4 Using patterns to solve problems	Comparing different arrangements	179 to 180

CAPS time allocation	4 hours
CAPS page references	19 and 169 to 171

While providing opportunities to develop understanding of patterns, continuing sequences or completing tables according to a pattern also contributes to the development of the **Mental Mathematics** section of the CAPS.

Mathematical background

The approach in this unit is not to reduce the work on geometric patterns to numeric patterns in tables – that too – but to capitalise on the *visual* aspects of geometric representations as a method to find **rules** based on the *structure* of the geometric figures.

This implies that you should help learners not to determine the number of dots in a figure by counting them one by one, but to use “clever counting” by identifying appropriate larger, repeating units. Then, learners shouldn’t just count the larger units, but rather write down a **numerical expression** (calculation plan or **rule**) describing the number of dots. It is very important that learners should learn to withhold immediate calculation of a numerical expression – what is needed is to analyse the structure of the expression as an object, and to *generalise the structure*, not to generalise numbers.

To find a general rule for the pattern requires a second level of pattern recognition, namely recognising the structure in a series of numerical expressions: what remains unchanged (is **constant**) and what changes (is **variable**). This process is illustrated below:

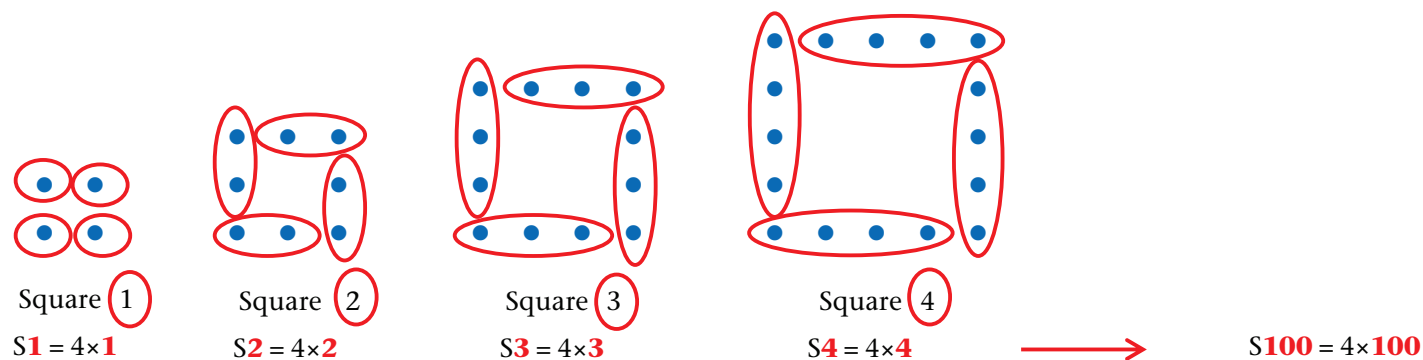

7.1 Making patterns

Teaching guidelines

We suggest that you present this first geometric pattern activity to the class, and solve the questions interactively with input and discussion from learners.

Remind them, and illustrate, that the big idea is not to count one by one, but to use “clever counting”, i.e. to identify larger repeating units – and then also not to count the units, but to write down a **calculation plan**. We illustrate this for question 1:

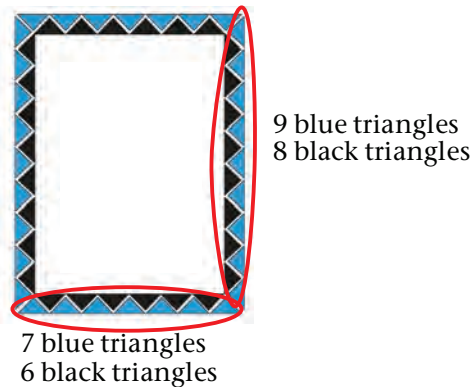

It is important for learners to “see” in the given drawing of the 9 by 7 border pattern that

- in the height there are 9 blue and 8 black triangles, and
- in the width there are 7 blue and 6 black triangles.

We can now write down our calculation plan:

- Calculation plan for the no. of blue triangles: $2 \times 9 + 2 \times 7$ or $2 \times (9+7)$
- Calculation plan for the no. of black triangles: $2 \times 8 + 2 \times 6$ or $2 \times (8+6)$
- Calculation plan for total: $2 \times 6 + 2 \times 7 + 2 \times 8 + 2 \times 9$ or $2 \times (6+7+8+9)$.

Note that for all the different sizes of this border pattern there is always one less black triangle than blue triangles in the height, and one less black triangle than blue triangles in the width.

Answers

- Blue: 32 Black: 28 Total: 60
- | | | |
|-----------------------------------|--------------------------------|---------------------------------------|
| (a) Blue: $2 \times (12+10) = 44$ | Black: $2 \times (11+9) = 40$ | Total: $2 \times (9+10+11+12) = 84$ |
| (b) Blue: $2 \times (15+10) = 50$ | Black: $2 \times (14+9) = 46$ | Total: $2 \times (9+10+14+15) = 96$ |
| (c) Blue: $2 \times (20+15) = 70$ | Black: $2 \times (19+14) = 66$ | Total: $2 \times (14+15+19+20) = 136$ |

UNIT
7
GEOMETRIC PATTERNS

7.1 Making patterns

This is a typical South African border pattern which is often put around pages, and used in pavings and on walls as decoration.

This is a Size 9 by 7 border pattern. It means that the pattern is 9 blue triangles high and 7 blue triangles wide.

- How many blue triangles, how many black triangles, and how many triangles are there in total in the border pattern above? Describe and discuss your method.

It takes too long to count in ones!

Mary first writes down her **calculation plan** before actually calculating it:

No. of blue triangles = $2 \times 9 + 2 \times 7 = 18 + 14 = 32$
 No. of black triangles = $2 \times 8 + 2 \times 6 = 16 + 12 = 28$
 Total no. of triangles = $32 + 28 = 60$

- Calculate the number of blue, the number of black and the total number of triangles in these border patterns of different sizes:

(a) 12 by 10	(b) 15 by 10	(c) 20 by 15
--------------	--------------	--------------

176
UNIT 7: GEOMETRIC PATTERNS

7.2 From pictures to tables

Teaching guidelines

From their experience with the way of thinking used in the previous section, you should now encourage learners to continue with “clever counting” and to **use structure** and not counting.

Give learners the opportunity to explain their methods and to learn from each other. Most learners should be able to use an approach as set out below, or to follow other learners explaining what they “see” and how they describe what they are seeing by means of calculation plans. Note that question 4 asks for a calculation plan for the total number of triangles in the pattern.



Length ①	Length ②	Length ③	Length ④
Black: 2×1	Black: 2×2	Black: 2×3	Black: 2×4
Blue: 2×2	Blue: 2×3	Blue: 2×4	Blue: 2×5
Total: $2 \times (1+2)$	Total: $2 \times (2+3)$	Total: $2 \times (3+4)$	Total: $2 \times (4+5)$

Answers

1. (a) Length 5: 5 black triangles at the bottom and 5 at the top, and 6 + 6 blue triangles.



2. (a) Length 50: 50 black triangles at the bottom, 50 black triangles at the top and 2×51 blue triangles.

(b) No. of triangles in Length 50 = $2 \times 50 + 2 \times 51 = 202$ or $2 \times (50 + 51) = 202$

Length	1	2	3	4	5	6	7	60
No. of black triangles	2	4	6	8	10	12	14	120
No. of blue triangles	4	6	8	10	12	14	16	122
Total no. of triangles	6	10	14	18	22	26	30	242

4. 1, 2, 3, 4, 20 \rightarrow $\boxed{\times 4} - \boxed{+ 2} \rightarrow$ 6, 10, 14, 18, 82

7.2 From pictures to tables

Zubeida uses this growing pattern of triangles of different lengths as a border pattern to decorate different lengths of walls.



- (a) Describe Length 5 in words.
(b) Now draw Length 5.
(c) How many triangles are there in Length 5?
- (a) Describe Length 50 in words.
Do not draw it! Imagine it; “see” it in your head!
(b) Write down a calculation plan to calculate the number of triangles in Length 50, and then calculate it.
- Complete this table. Describe and discuss your methods. Describe and discuss patterns in the table.

Length	1	2	3	4	5	6	7	60
No. of black triangles	2	4	6					
No. of blue triangles	4	6						
Total no. of triangles	6	10						

4. Complete this flow diagram:

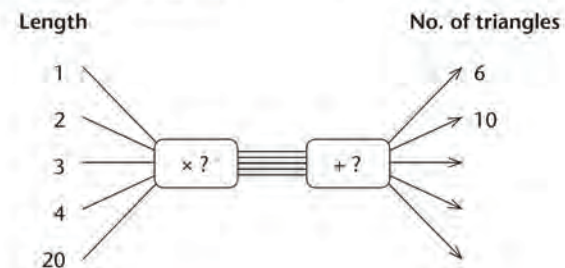

7.3 Extending patterns

Teaching guidelines

This section is quite challenging. We suggest that all learners should do question 1, but it is not necessary that all learners finish all the questions. It is more important to have a thorough discussion of the solution of question 1.

Answers

1. (a)

Size	1	2	3	4	5	6	30
No. of purple tiles	2	4	6	8	10	12	60
No. of white tiles	10	14	18	22	26	30	126
Total no. of tiles	12	18	24	30	36	42	186

- (b) Horizontal pattern: No. of purple tiles: 2 tiles are added to the previous size
 No. of white tiles: 4 tiles are added to the previous size
 Total no. of tiles: 6 tiles are added to the previous size
- Vertical pattern: No. of purple tiles: $\text{Size number} \times 2$
 No. of white tiles: $\text{Size number} \times 4 + 6$
 Total no. of tiles: $\text{Size number} \times 6 + 6$

2. (a)

Size	1	2	3	4	5	6	30
No. of purple tiles	2	4	6	8	10	12	60
No. of white tiles	10	17	24	31	38	45	213
Total no. of tiles	12	21	30	39	48	57	273

- (b) Horizontal pattern: Purple: + 2 tiles White: + 7 tiles Total: + 9 tiles
 Vertical pattern: Purple: $\text{Size number} \times 2$
 White: $\text{Size number} \times 7 + 3$
 Total: $\text{Size number} \times 9 + 3$

3. (a)

Size	1	2	3	4	5	6	30
No. of purple tiles	4	8	12	16	20	24	120
No. of white tiles	12	20	28	36	44	52	244
Total no. of tiles	16	28	40	52	64	76	364

- (b) Horizontal pattern: Purple: + 4 tiles White: + 8 tiles Total: + 12 tiles
 Vertical pattern: Purple: $\text{Size number} \times 4$
 White: $\text{Size number} \times 8 + 4$
 Total: $\text{Size number} \times 12 + 4$

7.3 Extending patterns

1. Purple tiles and white tiles are arranged to make this growing geometric pattern:



- (a) Complete the table. Describe and discuss your method.

Size	1	2	3	4	5	6	30
No. of purple tiles	2	4	6				
No. of white tiles	10						
Total no. of tiles	12						

- (b) Describe and discuss *horizontal* and *vertical* numeric patterns for the purple tiles and for the white tiles and for the total number of tiles in the table.

2. Answer the same questions as in question 1 for this tile pattern.



3. Answer the same questions as in question 1 for this tile pattern.

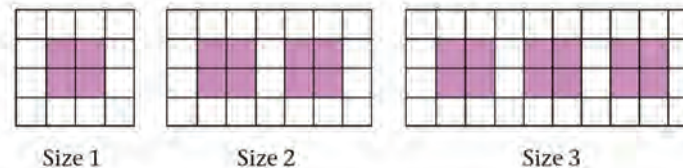

7.4 Using patterns to solve problems

Teaching guidelines

This is an interesting real-life problem. It may be somewhat time-consuming, but once learners get the hang of it, it should not be difficult. However, in order to solve the problem and to develop an understanding of structure, it is important that all learners do all the plans.

Mathematical notes

To calculate the number of people for a large number of tables, it is useful to find a calculation plan for each of Plans 1 to 4.

Again, it is not really difficult, and it certainly is not more challenging than finding the perimeter of the figures (with the people as “sides” or side lengths)!

The way to “see” structure is to understand that in Figure 4 we try to see a unit of 4, in Figure 3 we try to see a unit of 3 in the same way, in Figure 2 a unit of 2 and so on, as illustrated here for Plan 1:

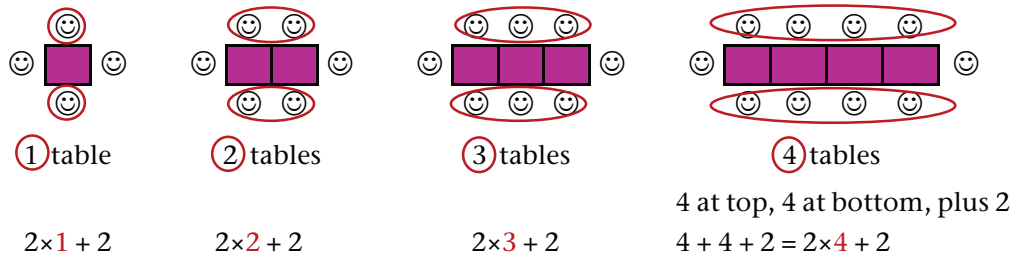

The challenge is then to generalise the structure so that we can, for example, easily calculate how many people will sit at 15 small tables:

$$T1 = 2 \times 1 + 2$$

$$T2 = 2 \times 2 + 2$$

$$T3 = 2 \times 3 + 2$$

$$T4 = 2 \times 4 + 2$$

⋮

$$\text{So, } T15 = 2 \times 15 + 2$$

The calculation plan as a flow diagram also helps us to find unknown input values by using inverse operations in reverse order, for example:

$$? \xrightarrow{-\boxed{\times 2}} \xrightarrow{-\boxed{+ 2}} \rightarrow 46$$

$$22 \xleftarrow{\boxed{\div 2}} \xleftarrow{\boxed{- 2}} \leftarrow 46$$

7.4 Using patterns to solve problems

Anand plans to invite many friends to his birthday party. He must decide how he will seat all his friends.

He wants to make one long table by pushing a number of smaller tables together. The sketches below show different plans for seating the guests around the tables. Anand wonders which plan will be the best. Can you help him decide?

Plan 1

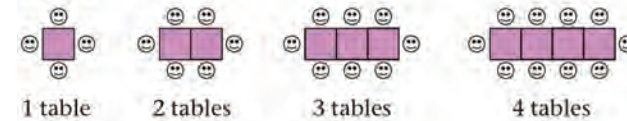

Plan 2

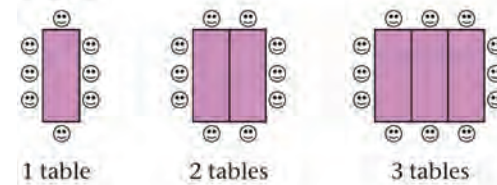

Plan 3

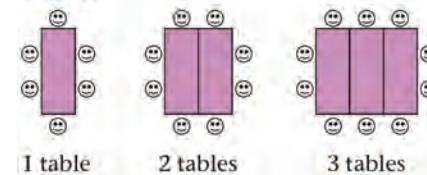

Plan 4

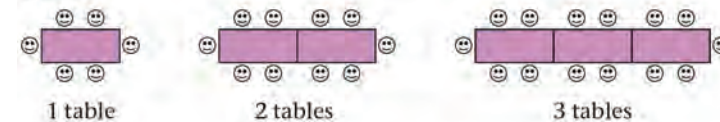

We briefly outline the thinking to find the rule for Plan 3 using visual structure:

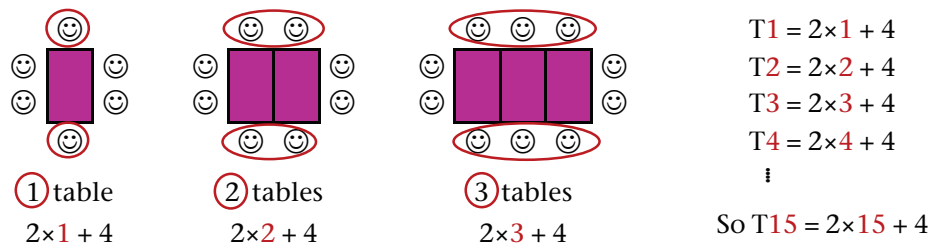

Answers

1. (a) Each square table can seat two people opposite each other, plus one person at each end of the combined row of tables (the “long table”).

(b) 1, 2, 3, 4, 5, 15, $22 - \boxed{\times 2} - \boxed{+ 2} \rightarrow 4, 6, 8, 10, 12, 32, 46$

No. of tables	1	2	3	4	5	15	22
No. of people	4	6	8	10	12	32	46

2. (a) Each table can seat two people at the short ends. And 6 people can sit at the other two sides of the combined row of tables.

(b) 1, 2, 3, 4, 5, 15, $20 - \boxed{\times 2} - \boxed{+ 6} \rightarrow 8, 10, 12, 14, 16, 36, 46$

No. of tables	1	2	3	4	5	15	20
No. of people	8	10	12	14	16	36	46

3. (a) Each table can seat two people at the short ends. And 4 people can sit at the other two sides of the combined row of tables.

(b) 1, 2, 3, 4, 5, 15, $21 - \boxed{\times 2} - \boxed{+ 4} \rightarrow 6, 8, 10, 12, 14, 34, 46$

No. of tables	1	2	3	4	5	15	21
No. of people	6	8	10	12	14	34	46

4. (a) Each table can seat four people opposite each other, plus one person at each end of the combined row of tables.

(b) 1, 2, 3, 4, 5, 15, $11 - \boxed{\times 4} - \boxed{+ 2} \rightarrow 6, 10, 14, 18, 22, 62, 46$

No. of tables	1	2	3	4	5	15	11
No. of people	6	10	14	18	22	62	46

5. Plan 4

1. For Plan 1:

(a) Describe in words how the seating works. (For example: “Each small table can seat two people, plus one person at each end of the long table.”)

(b) Complete this flow diagram. (You must fill in the missing input and output numbers and the calculation plan.)

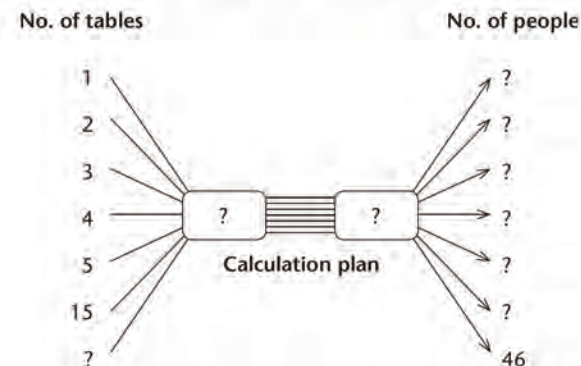

(c) Complete this table showing the relationship between the number of tables and the number of people.

No. of tables	1	2	3	4	5	15	
No. of people							46

2. For Plan 2, answer the same questions as for Plan 1.

3. For Plan 3, answer the same questions as for Plan 1.

4. For Plan 4, answer the same questions as for Plan 1.

5. If there will be 46 people at the party (including Anand), which plan needs the fewest number of tables?

Learner Book Overview		
Sections in this unit	Content	Pages in Learner Book
8.1 Drawing symmetrical figures	Identifying lines of symmetry and completing symmetrical drawings	181 to 182
8.2 Finding lines of symmetry	Identifying lines of symmetry; identifying symmetrically located points	183 to 184
8.3 Moving figures to make symmetries	Identifying symmetries resulting from moving a shape in various ways, and identifying absence of symmetry	185 to 186

CAPS time allocation	2 hours
CAPS page references	23 and 171

Mathematical background

Symmetry occurs when a shape or design can be seen as consisting of two “mirror images”. This means that a straight line, called the line of symmetry, can be drawn through the shape or design in such a way that if we fold along the line, every single line and point on one side of the line lies on top of its twin on the other side of the line – without exceptions. Some shapes have two or more lines of symmetry.

Symmetry is an intuitive concept that plays an important role in art and design – this forms the beginning of the unit. It is followed by a more formal look into symmetry – the symmetry of points. This develops the spatial skill of “seeing” symmetry. In the last section, learners have to identify symmetries and absence of symmetry in a variety of compound shapes.

This quadrilateral possesses no symmetry at all.

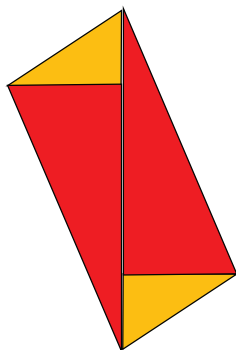

This quadrilateral has only one line of symmetry.

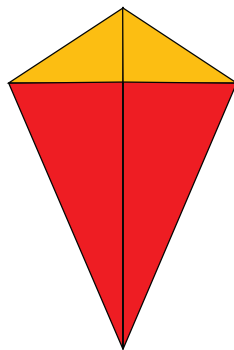

This quadrilateral has two lines of symmetry.

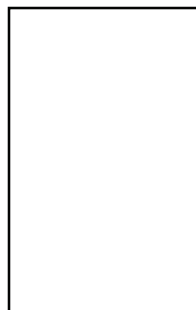

This quadrilateral has four lines of symmetry.



All the lines that pass through the centre of a circle are lines of symmetry.

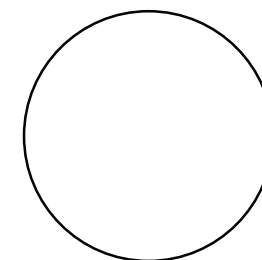

8.1 Drawing symmetrical figures

Teaching guidelines

The purpose of question 1 is to let learners physically experience symmetry by making symmetrical sets of movements with their two hands, or two successive sets of movements with the same hand. Learners may have to try repeatedly before they get it right. Allow them to share their experiences.

You can draw a simple symmetrical figure on the board to demonstrate what learners are required to do in question 1.

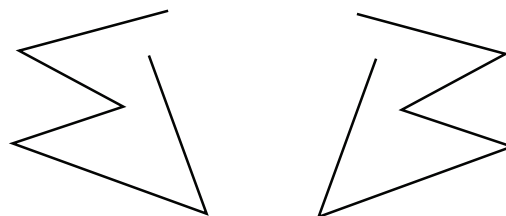

Another way to let learners experience symmetry is to give each learner a piece of cardboard or thick paper that can serve as a template for tracing a figure.

Let learners trace the outline of the template, then pick it up, flip it over and put it down again. They must try to put it down in a position that will produce symmetry when the outline is traced again, as shown below. Let learners then draw the approximate line of symmetry, without a ruler. (It is not accuracy that is important now, it is the ability to visualise where the line of symmetry is.) Note that the broken line figure below does not form a symmetrical design with the tracing on the left – it was shifted down.

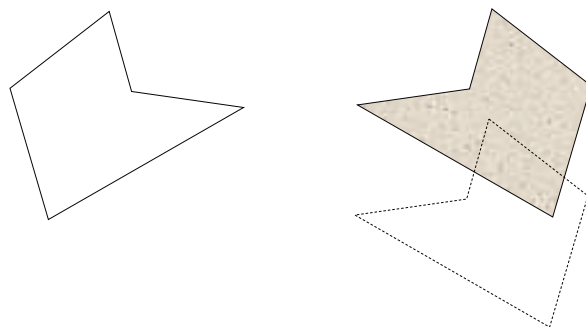

Answers

1. Practical activity
2. Pictures with a fold line that is a line of symmetry: (a), (c)

UNIT

8

SYMMETRY

8.1 Drawing symmetrical figures

Ma Esther Mahlangu is famous all over the world for her Ndebele art. She says she draws **symmetrical figures** like this: whatever she draws on the right, she also draws on the left.

1. Trace over the black lines of Ma Esther's symmetrical painting below using your two forefingers at the same time. Start in the middle at the top of the painting and trace the lines so that you do the same movements on the left and on the right.

If you can fold a diagram in half so that the two parts match exactly, the fold line is called a **line of symmetry**.



2. Which pictures show a fold line that is a line of symmetry?

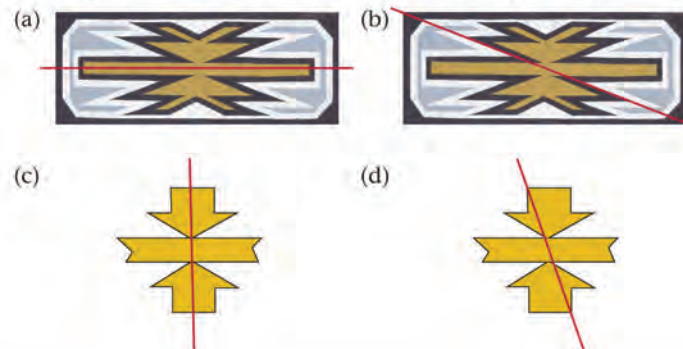

Teaching guidelines

You can do A and C on the board as examples – plot only the necessary dots beforehand.

We have provided dotted paper in the Addendum on page 415. However, it is not critical to have dotted paper. Working on lined paper is almost as good and will still allow the idea of symmetry to develop.

Answers

3. (a) Learners' own work

(b)

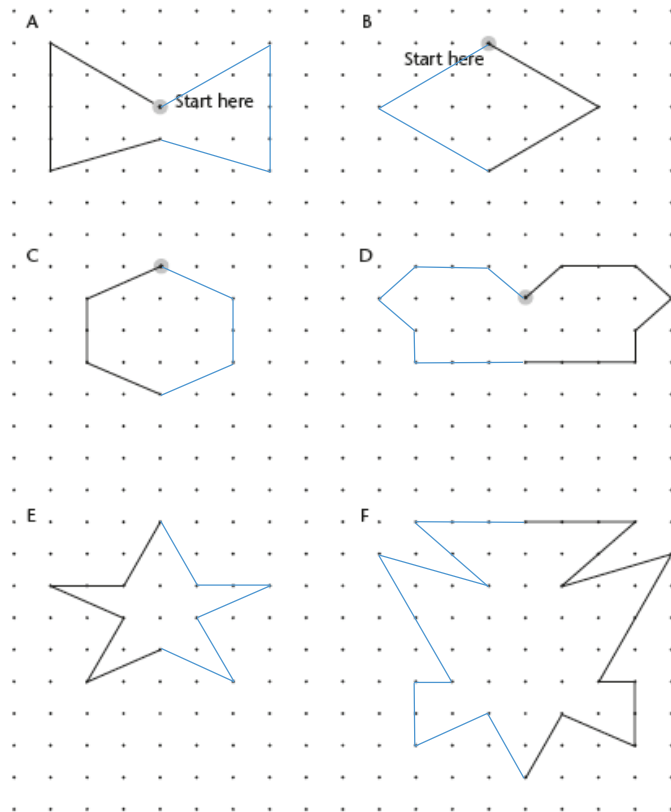

3. The figures show what one hand drew.
 (a) Redraw the figures on dotted paper.
 (b) Complete the figures to show what the other hand must draw to make a symmetrical figure.

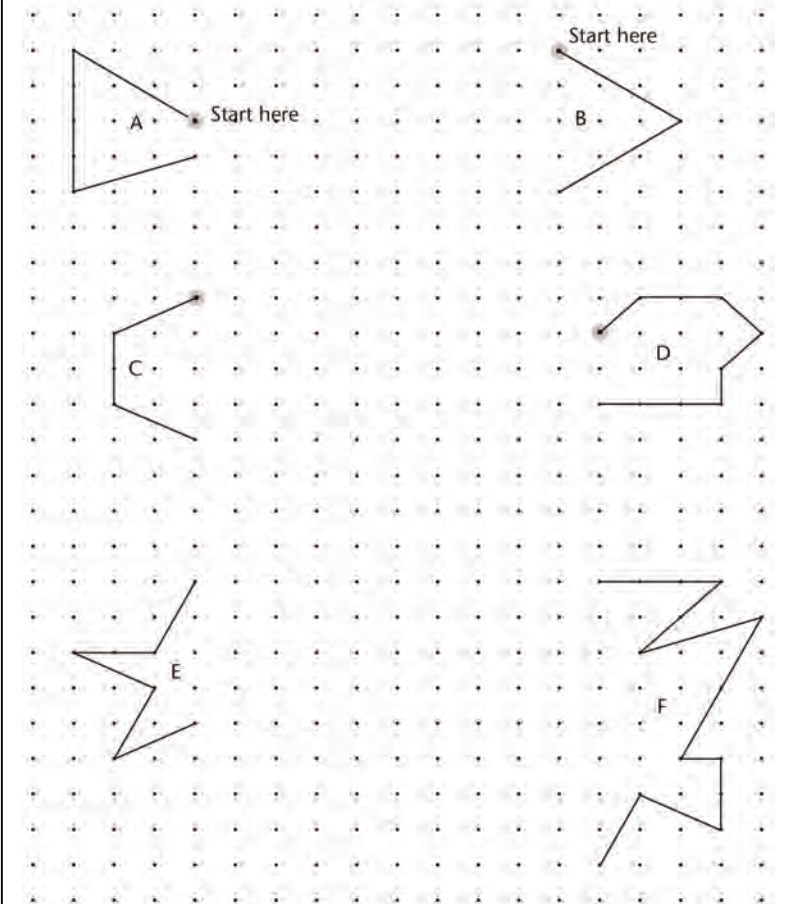

8.2 Finding lines of symmetry

Mathematical notes

Learners' individual spatial sense is challenged here, building on the challenges mentioned in the previous section.

Answers

1. (a)

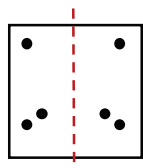

(b)

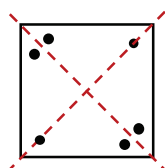

(c)

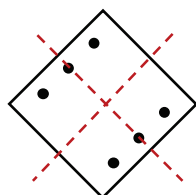

(d)

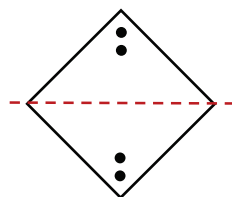

2. (a)

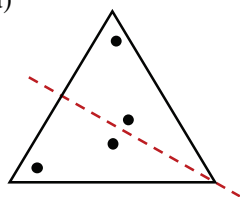

(b)

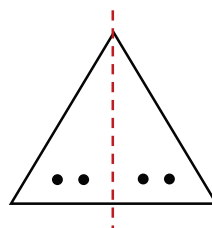

8.2 Finding lines of symmetry

- Where must you fold the square to make the dots fall onto each other? Trace each figure onto a clean page and draw a line of symmetry. Try to be accurate.

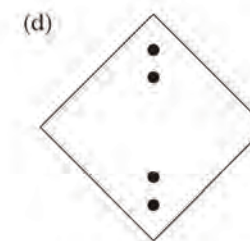
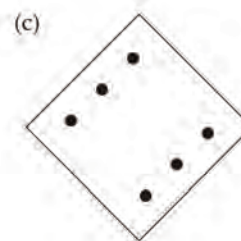
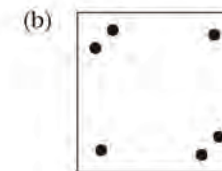
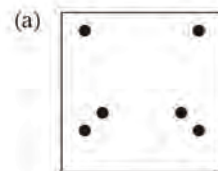

- Where must you fold the triangle to make the dots fall onto each other? Trace each figure onto a clean page and draw a line of symmetry. Try to be accurate.

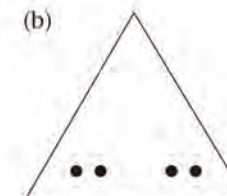
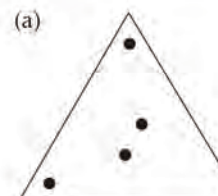

Answers

3. (a)

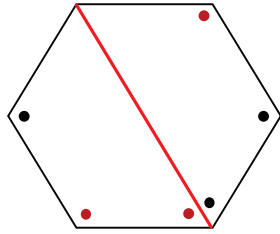

(b)

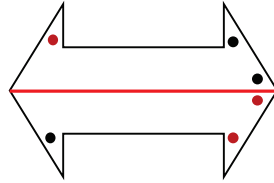

(c)

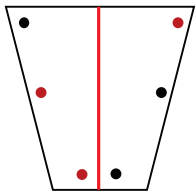

(d)

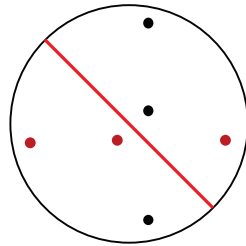

(e)

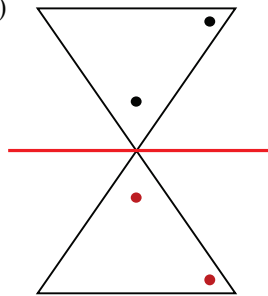

(f)

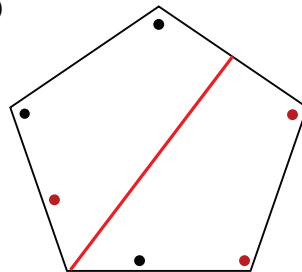

3. Lines of symmetry have been drawn in red on the figures. Trace each figure onto a clean page and draw the missing dots. Try to be accurate.

(a)

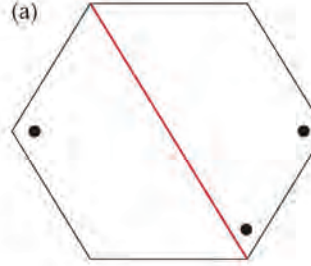

(b)

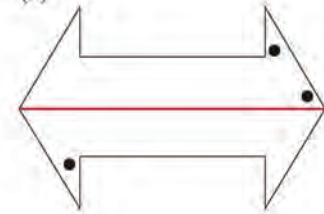

(c)

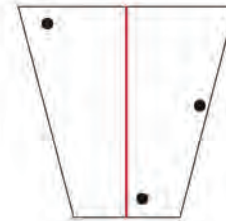

(d)

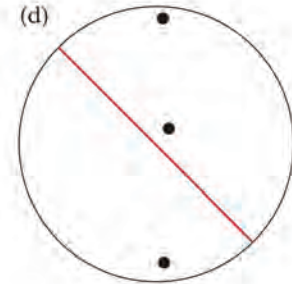

(e)

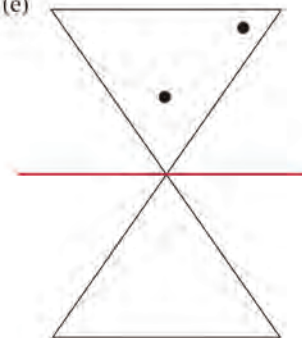

(f)

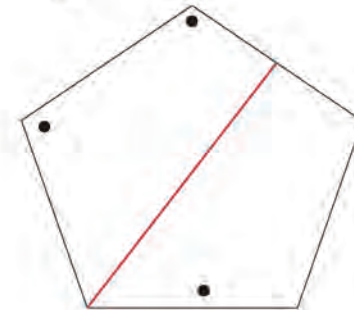

8.3 Moving figures to make symmetries

Teaching guidelines

The questions in this section require learners to identify symmetries and lines of symmetry (e.g. questions 1 and 2) as well as the absence of symmetry (question 3). The section hence provides for consolidation and refinement of the knowledge learners acquired in Sections 8.1 and 8.2.

The section also provides learners with experiences of the transformations they will learn about in Term 3 Unit 7: translations (questions 1 to 3), reflections (questions 4, 5 and 6(b)) and rotations (questions 4, 5 and 6(c)). However, there is no need for learners to name and engage formally with these transformations now: they only have to provide descriptions in their own language of how the hexagon was moved to form the repetitive designs (patterns) in the various questions.

The explicit references to transformations in the mathematical notes below and on the next page are provided as background orientation for teachers, not with the intention that this should be discussed with learners at this stage.

Mathematical notes

When a symmetrical shape is shifted along the line of symmetry without turning it, the symmetry is repeated and a compound symmetrical design is formed, as demonstrated in the designs in questions 1 and 2.

Shifting a symmetrical shape along a line other than the line of symmetry does not create more symmetries, as shown in question 3.

Answers

- The hexagon was moved 5 squares to the right.
 - The red line
- The hexagon was moved 4, then 5, then 6 squares to the right.
 - The red line
 - Many learners may say “yes”, which is wrong. Allow learners to do question 3 to realise that shifting a symmetrical figure along a straight line does not necessarily produce more symmetries.
- The hexagon was moved 6 squares to the right and 1 square down.
 - None

8.3 Moving figures to make symmetries

- How was the first hexagon moved to form the pattern?

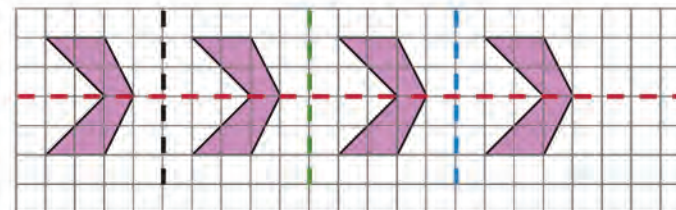

- Which of the broken lines are lines of symmetry of the pattern?
- How was the hexagon now moved to form this pattern?

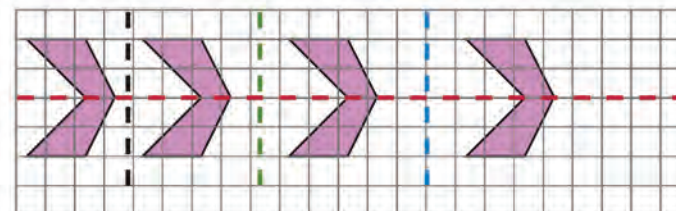

- Which of the broken lines are lines of symmetry of this pattern?
 - Do you think you will always get a symmetrical pattern when you shift a symmetrical figure along a straight line?
- How was the hexagon now moved to form a pattern?

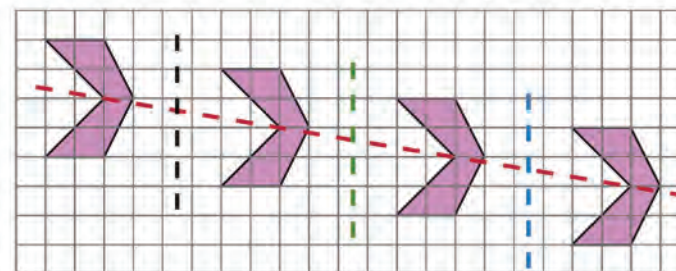

- Which of the broken lines are lines of symmetry of this pattern?

Mathematical notes

A symmetrical design is created when a shape is flipped over. The design in question 4(a) can be produced by flipping the hexagon over the black vertical broken line, then over the green broken line, then over the blue broken line.

The symmetrical design in question 4(a) can also be produced by turning (rotating) the symmetrical hexagon through 180° , around the intersection of the extended axis of symmetry (the red broken line) and the vertical broken lines.

Answers

4. (a) The hexagon can be “flipped over” to the right, and again and again. Learners may use different language. The pattern can also be produced by turning the hexagon halfway around, around the points where the horizontal and vertical broken lines cross.

- (b) The red, black, green and blue lines
- (c) The black and blue lines

5. (a) The hexagon can be shifted to the right and down and flipped over to the right. Alternatively, it can be turned halfway around the points where the horizontal and vertical broken lines cross.

- (b) None

6. (a) No symmetries

(b) The group of four hexagons is symmetrical around the green broken line. The two hexagons on the left are symmetrical around the black broken line, and the two hexagons on the right are symmetrical around the blue broken line.

(c) No symmetries

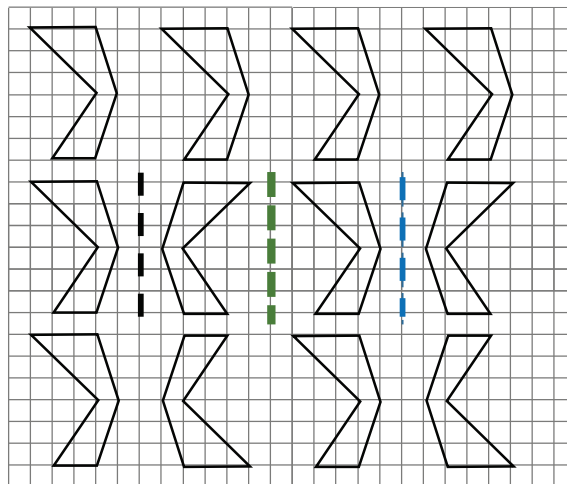

4. (a) How was the hexagon now moved to form a pattern?

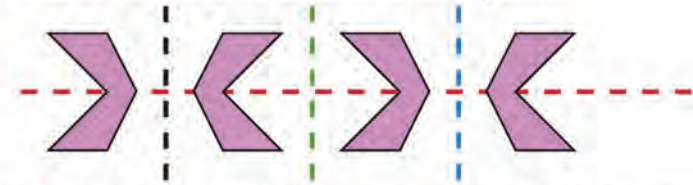

- (b) Which of the broken lines are lines of symmetry of this pattern?
- (c) Which of the broken lines are lines of symmetry of parts of the pattern, but not of the whole pattern? For which parts?

5. (a) How was the hexagon now moved to form a pattern?

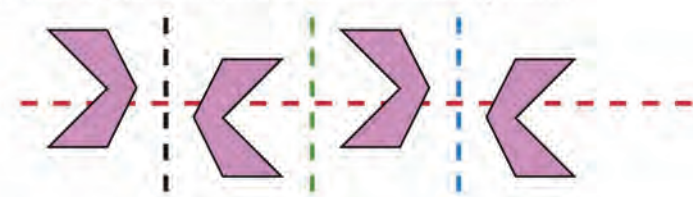

- (b) Which of the broken lines are lines of symmetry of this pattern?

6. Draw these three patterns on grid paper.

Also draw any lines of symmetry that you see in any of the patterns.

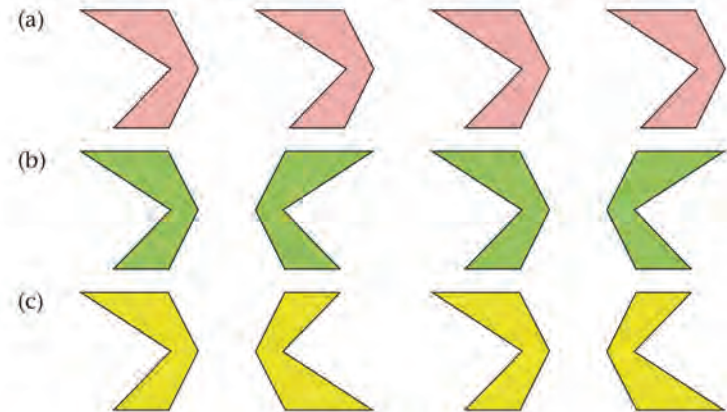

Learner Book Overview		
Sections in this unit	Content	Pages in Learner Book
9.1 Build multiplication knowledge for division	Mental Mathematics	187 to 188
9.2 Use multiplication facts to do division	Building up and breaking down numbers	189 to 190
9.3 Find answers for practical questions	Solving problems by division	191 to 192
9.4 Multiply and divide	Contextual questions on multiplication and division including ratio	193 to 195

CAPS time allocation	8 hours
CAPS page references	13 to 15 and 172 to 173

Mathematical background

Division is applicable to three different kinds of situations:

- Situations in which a quantity is shared (divided) into a **given number of parts** of unknown equal size – thus, a situation in which the number of equal parts is known but the size of each part is unknown.
- Situations in which a quantity is shared (divided) into an unknown number of **parts of given equal size** – thus, a situation in which the number of equal parts is unknown but the size of each part is known.
- Scaling situations where two quantities of the same kind are compared in terms of their **ratio**, not the difference between the two quantities.

The first step in division is to **estimate** what to multiply the divisor by to reach an answer smaller than the dividend.

For example, when calculating $6\,247 \div 87$ one may estimate that 50×87 will be smaller than 6 247. Since $50 \times 87 = 4\,350$ (half of 100×87 , which is 8 700), in this case it proves to be a good estimate.

The next step could now be $20 \times 87 = 1\,740$, leading to $70 \times 87 = 4\,350 + 1\,740 = 6\,090$, which is already close to 6 247.

One may add 87 to get closer: $71 \times 87 = 6\,090 + 87 = 6\,177$.

Since $6\,247 - 6\,177 = 70$, the answer is $6\,247 \div 87 = 71$ remainder 70.

This may also be expressed by writing $6\,247 = 71 \times 87 + 70$.

9.1 Build multiplication knowledge for division

Teaching guidelines

The first step in dividing with multi-digit numbers is to make an estimate that can serve as a starting point (see “Mathematical background” on the previous page). Hence, questions 1 and 2 provide learners with opportunities to strengthen their estimation skills.

You may start the lesson by asking learners to study questions 1(a)–(h) and 2(a)–(j) and to then write down estimated answers. Having to estimate answers will help learners to apply their minds to understand given situations, which is an essential element of problem solving. Then ask them to check their answers by using multiplication.

Once learners have started working on questions 1 and 2, you may suggest that they revise their estimates as they progress.

Answers

In questions 1 and 2 there is sometimes more than one solution. Consider learners’ answers.

- | | |
|-----------------------------|-------------------|
| (a) 475; 476; 477; 478; 479 | (b) 317; 318; 319 |
| (c) 238; 239 | (d) 190; 191 |
| (e) 159 | (f) 136; 137 |
| (g) 119 | (h) 106 |
- | | |
|------------|------------|
| (a) 95; 96 | (b) 87; 88 |
| (c) 80 | (d) 74 |
| (e) 68; 69 | (f) 64 |
| (g) 60 | (h) 56; 57 |
| (i) 53 | (j) 50; 51 |
- | | |
|---------|-----------|
| (a) 460 | (b) 860 |
| (c) 680 | (d) 1 110 |

UNIT

9

WHOLE NUMBERS:

DIVISION

9.1 Build multiplication knowledge for division

- Find the missing number in each case. You may estimate, check and correct.
 - $2 \times \dots$ is at least 950, but less than 960.
 - $3 \times \dots$ is at least 950, but less than 960.
 - $4 \times \dots$ is at least 950, but less than 960.
 - $5 \times \dots$ is at least 950, but less than 960.
 - $6 \times \dots$ is at least 950, but less than 960.
 - $7 \times \dots$ is at least 950, but less than 960.
 - $8 \times \dots$ is at least 950, but less than 960.
 - $9 \times \dots$ is at least 950, but less than 960.
- Find the missing number in each case.
 - $10 \times \dots$ is at least 950, but less than 970.
 - $11 \times \dots$ is at least 950, but less than 970.
 - $12 \times \dots$ is at least 950, but less than 970.
 - $13 \times \dots$ is at least 950, but less than 970.
 - $14 \times \dots$ is at least 950, but less than 970.
 - $15 \times \dots$ is at least 950, but less than 970.
 - $16 \times \dots$ is at least 950, but less than 970.
 - $17 \times \dots$ is at least 950, but less than 970.
 - $18 \times \dots$ is at least 950, but less than 970.
 - $19 \times \dots$ is at least 950, but less than 970.
- How much is each of the following?

(a) 23×20	(b) 43×20
(c) 17×40	(d) 37×30

Teaching guidelines

When learners start with question 4, suggest that they make estimates as in questions 1 and 2, and then check their answers by doing multiplication. They may observe that the answers for question 3 can help them to quickly produce the answers for question 4. This is fine.

Answers

4. (a) 23 (b) 20
(c) 20 (d) 43
5. (a) $460 + 115 = 575$ (b) 575
(c) $690 + 92 = 782$ (d) 782

Notes on questions

Like questions 3 and 4, but in a different way, question 6 demonstrates the relationship between multiplication and division.

Thus, in question 6(a) learners may say $18 \times 24 = 432$ or $24 \times 18 = 432$.

In question 6(b) learners know that the number of rings is neither increased nor decreased, therefore: $432 \div 12 = 36$. This means that $12 \times 36 = 432$. This implies that Nathi will rearrange the rings into 36 rows of 12 rings in each.

Answers

6. (a) 432 (b) 36 (c) 54 (d) 48
7. 30
8. 20

4. How much is each of the following?
(a) $460 \div 20$ (b) $460 \div 23$
(c) $860 \div 43$ (d) $860 \div 20$
5. How much is each of the following? (Do the multiplications first if both multiplication and addition are required.)
(a) $23 \times 20 + 23 \times 5$ (b) 23×25
(c) $23 \times 30 + 23 \times 4$ (d) 23×34
6. (a) 18 rows of 24 rings are shown below. How many rings are there altogether?

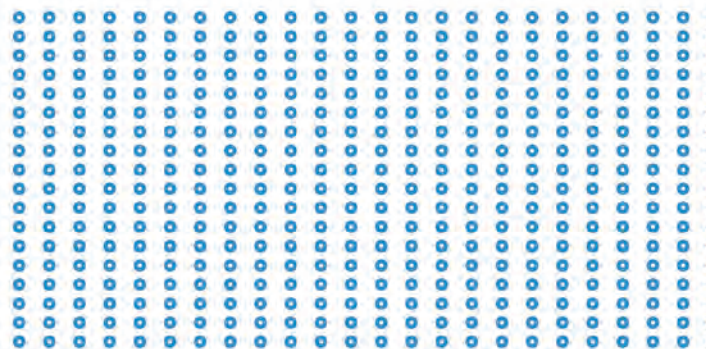

- (b) Nathi wants to rearrange these rings into rows with 12 rings each. How many rows will that be?
- (c) How many rings will there be in each row if the rings are arranged into 8 equal rows?
- (d) How many rings will there be in each row if the rings are arranged into 9 equal rows?
7. 720 rings are arranged in rows of 24 rings each. How many rows are there?
8. 720 rings are arranged in 36 equal rows. How many rings are there in each row?

9.2 Use multiplication facts to do division

Teaching guidelines

The contexts described in Situations A and B may be utilised as a platform for learners to strengthen their knowledge of how to do division with multi-digit numbers. For this to happen, it is critical that learners engage with the context in their minds. To help them do that, you may bring a box to class. Say to learners that you want to put 24 apples in the box. Ask them to estimate how many such boxes with 24 apples each can be made up from a total of 774 apples. Let them write their estimates down.

To help learners to engage in their minds with Situation B, you may say that you would like 24 of them to each take some apples home. State that you have 774 apples available, and ask them to estimate how many apples each of the 24 lucky learners will get to take home, if they share the apples equally among them. Let them write their estimates down.

Now ask learners how much 24×2 is, then how much 24×10 is, as well as 24×20 and 24×30 . Confirm the correct answers and let learners write all the answers down, in the form $24 \times 2 = 48$, $24 \times 10 = 240$, etc. (This is what is sometimes called a “clue board”.)

Remind learners of Situations A and B again and of the estimates they wrote down. Suggest that they use the multiplication facts for 24 that they have just written down to check and revise their estimates for Situations A and B. Only then let them do question 1.

Answers

- Situation A:
 $24 \times 30 = 720$ and $24 \times 2 = 48$, hence $24 \times 32 = 720 + 48 = 768$
 $774 - 768 = 6$
Therefore 32 boxes are needed (and there will be 6 loose apples left over).
Situation B:
Each household can get 32 apples (and there will be 6 apples left over).

Teaching guidelines

Let learners engage with Situations C and D by themselves. They do not have to read the tinted passage at the top of page 190 of the Learner Book.

9.2 Use multiplication facts to do division

Read questions A and B below. Think about them but do not work out the answers.

- 774 apples must be packed in boxes, with 24 apples in each box. How many boxes are needed?
- 774 apples must be equally shared between 24 households. How many apples can each household get?

You may know that

$$24 \times 2 = 48 \text{ and}$$

$$24 \times 10 = 240.$$

Using this, you can work out that

$$24 \times 20 = 480, \text{ and that}$$

$$24 \times 30 = 24 \times 10 + 24 \times 20,$$

and that is $240 + 480$ which is 720.

$$\text{So } 24 \times 30 = 720.$$

- Can you use the multiplication facts $24 \times 2 = 48$ and $24 \times 30 = 720$ to help you to find the answers to questions A and B above? Answer the questions now.

To answer questions A and B you worked out what 24 must be multiplied by in order to get 774 or close to 774.

This is the same as working out how many parts of 24 each there are in 774. We call this **division** and write this as $774 \div 24$.

Now think about questions C and D below. Do not work out the answers.

- 768 apples must be packed in boxes, with 27 apples in each box. How many boxes are needed?
- 768 apples must be equally shared between 27 households. How many apples should each household get?

To answer questions C and D we have to work out how much $768 \div 27$ is. This is the same as working out by what 27 must be multiplied to get 768 or close to it.

Read the next page to see how we can find this out.

Teaching guidelines

If learners do not seem to make progress with Situations C and D, you may ask them to write down some multiplication facts for 27, like they did for 24. Then they should check whether these facts could help them to make good estimates with respect to Situations C and D.

The word “remainder” is not a new term but some learners may not know it or its implications. Therefore it is important to explain it and demonstrate what it means with a simple example such as the following:

$25 \div 4 = 6$ remainder 1. The understanding here is $4 \times 6 + 1 = 25$.

The amount left over after performing division is called a remainder.

Answers

2. $10 \times 33 = 330$ and double 330 is 660 (so $20 \times 33 = 660$)

Half of 330 is $5 \times 33 = 165$

$660 + 165 = 825$ (That is 25×33)

$825 + 33 = 858$ (That is 26×33)

$870 - 858 = 12$

Answer: $870 \div 33 = 26$ remainder 12

3. (a) 22 rem 9 (b) 8 rem 1 (c) 32 rem 12 (d) 7 rem 2

A good way to start to develop an answer to this question is to ask yourself what **multiplication facts** about 27 you already know, or can easily make up.

For example, you may know that $27 \times 10 = 270$.

Half of that is $27 \times 5 = 135$.

27×20 is 270 doubled, so it is 540.

We now use this knowledge to find out by what 27 must be multiplied to get 768:

$27 \times 20 = 540$ and $27 \times 5 = 135$,

so $27 \times 25 = 540 + 135$ which is 675.

So 25 is not the answer yet. We need some more 27s.

$675 + 27 \rightarrow 702 + 27 \rightarrow 729 + 27 \rightarrow 756$

So now we know that $27 \times 25 + 27 \times 3 = 756$, which means that $27 \times 28 = 756$.

12 more is needed to get to 768. The shortfall of 12 is the **remainder**.

This means that 27 must be multiplied by 28, and 12 must be added in order to get 768.

We write this in symbols as $768 = 27 \times 28 + 12$.

The answer can also be written like this:

$768 \div 27 = 28$ remainder 12.

The mathematical statement

$768 \div 27 = 28$ remainder 12

tells us that $768 = 27 \times 28 + 12$.

You do not have to write so much when you do division yourself!

Just write what you really need to when you do questions 2 and 3.

2. Calculate $870 \div 33$.

You may start by writing down some multiplication facts about 33, for example 10×33 and then you can double it.

3. Calculate.

(a) $625 \div 28$

(b) $625 \div 78$

(c) $876 \div 27$

(d) $548 \div 78$

9.3 Find answers for practical questions

Notes on questions

Question 1 is designed to support learners who have not yet developed a strong sense of division.

(Learners who do already have a strong understanding of division may quickly calculate $24 \times 16 = 384$ and proceed to add another 16 boxes to bring the total to $384 + 384 = 768$ and then add a smaller number of boxes. Alternatively, such learners may add 20 boxes (480 cans) to the first 384 cans to reach 864 cans, then add 5 boxes (half of 10) to reach $864 + 120 = 984$. This would reveal that to reach 1 000 cans, a total of 26 boxes must be added and there will then be a surplus of 8 cans. Learners who figure this out by themselves may continue on their own with question 2 and the subsequent questions.)

Question 1 is deliberately designed to be understood as: “How many groups of 24 cans must be added to 16×24 to make up 1 000 cans?” If learners do not make quick progress, you may ask them how many boxes are already there, and to calculate how many cans there are in these boxes. If learners do this but do not proceed further on their own, you may ask them how many cans they will have in total if they add another 20 boxes.

Once all learners have produced the answer for question 1 (26 boxes plus a box of 16 cans), you may point out that they have actually calculated $616 \div 24$ and obtained the answer 25 remainder 16. Highlight to them that they have multiplied (and added) in order to find the answer to a division problem, and suggest that they do this again when they do questions 2, 3 and 4.

Answers

- $1\ 000 - 384 = 616$ more cans
 $616 = 25 \times 24 + 16$, so 25 boxes with 24 cans and 1 box with 16 cans are needed.
Alternatively: $1\ 000 \div 24 = 41$ boxes and remainder 16 “loose cans”
 41 boxes – 16 boxes = 25 full boxes, so 25 boxes + 16 loose cans are needed.
- (a) $1\ 000 = 23 \times 43 + 11$, which means 23 truckloads of 43 bags and 1 truckload of 11 bags in total.
(b) $500 = 11 \times 43 + 27$, which means 11 truckloads of 43 bags and 1 truckload of 27 bags in total.
- (a) 17 chickens (b) 8 chickens (c) 10 chickens (d) 18 chickens
- $851 = 23 \times 37$, which means 37 trees in each row.

9.3 Find answers for practical questions

- Some boxes with cans of beans are shown below. How many more boxes must be added so that there will be 1 000 cans altogether?

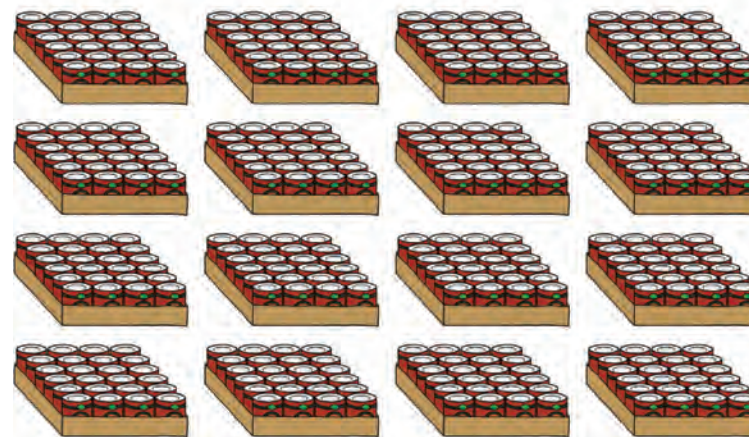

- A certain truck can carry 43 bags of cement.
 - How many truckloads must be delivered if 1 000 bags of cement are needed on a construction site?
 - How many truckloads must be delivered if 500 bags of cement are needed on a construction site?
- How many chickens at R57 each can be bought with R1 000?
 - How many chickens at R57 each can be bought with R500?
 - How many chickens at R57 each can be bought with R570?
 - How many chickens at R57 each can be bought with R1 070?
- 851 trees are planted in 23 equal rows. How many trees are there in each row?

Notes on questions

The solutions to question 6 provide learners with an opportunity to learn that quantities may not always be shared into equal parts (like in question 5).

Answers

5. Total number of learners is $76 + (68 + 68) + 59 + 74 = 345$.
 $345 \div 5 = 69$
There will be 69 learners on each bus.
6. Learners' answers will differ.
- (a) Three examples:
 $634 = 8 \times 75 + 34$, which means 8 buses with 75 learners and 1 bus with 34 learners.
 $634 = 4 \times 80 + 3 \times 85 + 1 \times 59$, which means 4 buses with 80 learners, 3 buses with 85 learners and 1 bus with 59 learners.
 $634 = 89 + 87 + 85 + 84 + 80 + 75 + 74 + 60$, which means a different number of learners on each of the nine buses.
- (b) Three examples:
 $634 = 8 \times 70 + 1 \times 74 \rightarrow$ 8 buses with 70 learners and 1 bus with 74 learners
 $634 = 8 \times 71 + 1 \times 66 \rightarrow$ 8 buses with 71 learners and 1 bus with 66 learners
 $634 = 8 \times 72 + 1 \times 58 \rightarrow$ 8 buses with 72 learners and 1 bus with 58 learners
- (c) One example:
 $634 = 5 \times 71 + 3 \times 69 + 1 \times 72 \rightarrow$ 5 buses with 71 learners, 3 buses with 69 learners and 1 bus with 72 learners
7. It won't work to only look at the given prices of buses and then draw conclusions. Learners must first determine the number of buses per option by dividing 832 learners by the number of seats in each kind of bus. The quotient must be multiplied by the amount as defined by the option.
- Option A: $832 \div 23 = 36$ remainder 4, so 37 buses are needed.
Thirty-seven buses will cost $37 \times R210 = R7\ 770$.
- Option B: $832 \div 92 = 9$ remainder 4, so 10 buses are needed.
Ten buses will cost $10 \times R828 = R8\ 280$.
- Option A is therefore cheaper.

5. All the learners of a primary school are going on a school outing. They are travelling on five buses:
- There are 76 learners on Bus A.
There are 68 learners each on Buses B and C.
There are 59 learners on Bus D.
There are 74 learners on Bus E.
- When they travel back to school, the buses will all carry an equal number of learners. How many learners will there be on each bus?
6. 634 learners have to be transported in 9 buses which are all the same size.
- (a) Describe *three* different possibilities of how many learners can go in each bus. The numbers need not be the same for each bus.
- (b) How many learners should go in each bus, if the number must be the same for eight of the nine buses? Again describe *three* different possibilities.
- (c) Five of the nine buses must each carry the same number of learners. Three of the nine buses must also each carry the same number of learners but that number must be different than the number for the five buses. Describe *one* possibility of how many learners should go in each of the nine buses.
7. Transport for 832 learners must be arranged. Two possibilities are available:
- Option A:*
Small buses that can carry 23 passengers each, at R210 for each bus.
- Option B:*
Large buses that can carry 92 passengers each, at R828 for each bus.
- Which option is cheaper?

9.4 Multiply and divide

Mathematical notes

This section provides learners with opportunities to become aware of constant ratios between quantities. This is emphasised from question 7 onwards.

Teaching guidelines

It is critical that learners engage with the structure of Thandi's beaded mat. To ensure this, you may ask them to count the number of beads of each colour before they start working on the questions. The numbers are:

7 blue beads 14 yellow beads 21 green beads 28 red beads
35 pink beads 42 brown beads

Questions 1 to 6 involve multiplication and division only.

Answers

- Learners may approach this in different ways.
Some learners may see: $7 \times 21 = 147$ beads.
Some may see: $7 + 14 + 21 + 28 + 35 + 42 = 147$ beads.
- 1 260 red beads
- (a) 21 mats; 15 beads left over (b) 147 (c) 588
- (a) 19 mats; 2 beads left over (b) 399 (c) 665
- (a) 322 yellow beads (b) 805 pink beads
- $882 \div 147 = 6$ mats, so she used:
42 blue beads
84 yellow beads
126 green beads
168 red beads
210 pink beads
252 brown beads

9.4 Multiply and divide

Thandi makes beaded mats and sells them at the craft market.

All her mats have the same pattern.

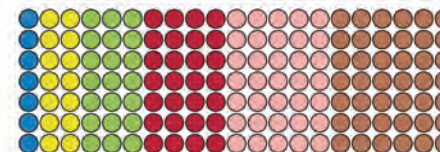

Look at Thandi's mat. Then answer questions 1 to 6.

- How many beads are there in one of Thandi's mats?
- How many red beads does Thandi need to make 45 mats?
- At one time Thandi has only 750 pink beads available.
 - How many mats can she make, and how many pink beads will be left over?
 - How many blue beads will Thandi need for the mats she can make with 750 pink beads?
 - How many red beads will Thandi need for the mats she can make with 750 pink beads?
- At one time Thandi has only 800 brown beads available.
 - How many mats can she make, and how many brown beads will be left over?
 - How many green beads will Thandi need for the mats she can make with 800 brown beads?
 - How many pink beads will Thandi need for the mats she can make with 800 brown beads?
- At one time Thandi has only 650 red beads available.
 - How many yellow beads will Thandi need for the mats she can make with 650 red beads?
 - How many pink beads will Thandi need now?
- During a certain week, Thandi used a total of 882 beads to make mats like the above. How many beads of each colour did she use?

Teaching guidelines

The language construction in question 7 conveys the idea of a ratio. There is no need to introduce the word “ratio” before learners have completed question 7.

Question 8 is more demanding than question 7. It may be necessary to do question 8(a) with the whole class, after learners have engaged with it for a while by themselves.

Answers

7. (a) True (b) True (c) False (d) False
(e) False (f) True (g) True
8. (a) 2 to 5 (b) 5 to 2 (c) 4 to 6 (or 2 to 3)
(d) 1 to 4 (e) 4 to 1

Here you can again see the drawing of Thandi's mat.

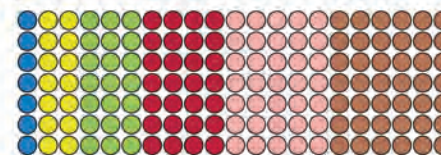

7. Look carefully at Thandi's mat. Then decide which of the following statements are true, and which are false.
- (a) For every 4 red beads Thandi uses, she uses 6 brown beads.
 - (b) For every 14 yellow beads Thandi uses, she uses 21 green beads.
 - (c) For every 7 pink beads Thandi uses, she uses 8 brown beads.
 - (d) For every 2 yellow beads Thandi uses, she uses 5 red beads.
 - (e) For every blue bead Thandi uses, she uses 21 green beads.
 - (f) For every green bead Thandi uses, she uses 2 brown beads.
 - (g) For every 3 green beads Thandi uses, she uses 5 pink beads.

The word **ratio** can also be used to compare the numbers of beads of different colours in situations like the above. For example, instead of saying:

“For every 3 green beads Thandi uses, she uses 5 pink beads.”
we can say:

“**The ratio** of green beads to pink beads **is** 3 to 5.” or

“The green beads and the pink beads **are in the ratio** 3 to 5.”

8. Now take another look at Thandi's mat. In what ratio is each of the following?
- (a) the number of yellow beads and the number of pink beads
 - (b) the number of pink beads and the number of yellow beads
 - (c) the number of red beads and the number of brown beads
 - (d) the number of blue beads and the number of red beads
 - (e) the number of red beads and the number of blue beads

Answers

9. (a) 60 yellow beads
 (b) 450 brown beads
 (c) 80 red beads
10. 360 blue beads; 120 yellow beads; 160 red beads
11. The ratios are the same for all three mats:

blue to yellow to red to green to pink to brown
 5 to 3 to 4 to 3 to 4 to 2

Cindy also makes beaded mats. In each of Cindy's mats

- yellow and red beads are in the ratio 3 to 4,
- blue and brown beads are in the ratio 2 to 5, and
- yellow and blue beads are in the ratio 1 to 3.

9. There are 180 blue beads in one of Cindy's mats.
- (a) How many yellow beads are there in this mat?
 (b) How many brown beads are there in this mat?
 (c) How many red beads are there in this mat?
10. One day, Cindy has no beads left. She buys 900 brown beads and decides to use all 900 brown beads in one large mat. How many blue, yellow and red beads will she have to buy for this mat?

Here you can see three mats that Belinda made. Look at them carefully and then answer question 11.

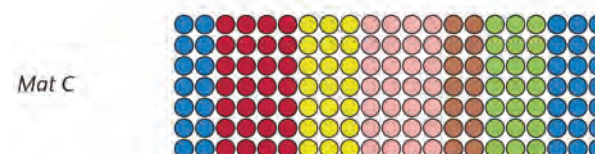
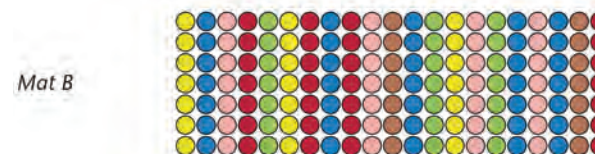

11. Describe Belinda's three mats by stating all the ratios between the numbers of beads of different colours.

Term 3

Unit 1: Common fractions	217
1.1 Parts of wholes and parts of collections	218
1.2 Equivalent fractions	221
1.3 Parts of a measuring unit	223
1.4 Combining, comparing and ordering fractions	225
1.5 Calculating a fraction of a quantity	227
1.6 Addition and subtraction of fractions	228
Unit 2: Mass	230
2.1 Models of kilograms and grams	231
2.2 Estimating and measuring mass	232
2.3 The relationship between grams and kilograms	234
2.4 Counting in grams and kilograms, and reading scales	235
2.5 Solving problems about mass and quantity	237
Unit 3: Whole numbers	238
3.1 Compare and order numbers	239
3.2 Represent and compare numbers	242
3.3 An investigation	243
Unit 4: Whole numbers: Addition and subtraction	244
4.1 Revision, and adding in columns	245
4.2 Subtracting in columns	248
4.3 Less writing when adding in columns	250
4.4 Another way of subtracting in columns	253
4.5 Solve problems	254
Unit 5: Viewing objects	255
5.1 Different views of the same object	256
5.2 What you see from different places	257

Unit 6: Properties of two-dimensional shapes	259
6.1 Draw figures on grid paper	260
6.2 Figures with equal sides and right angles	262
6.3 Figures inside circles	264
Unit 7: Transformations	266
7.1 Making patterns by moving a shape	267
7.2 Rotations	270
7.3 Reflections and translations	273
Unit 8: Temperature	277
8.1 Estimating and measuring temperature	278
8.2 Weather temperatures	281
Unit 9: Data handling	283
9.1 Collecting and organising data in categories	284
9.2 Collecting and organising numerical data	287
Unit 10: Numeric patterns	291
10.1 More sequences	292
10.2 Patterns in tables	293
10.3 Using patterns to solve problems	294
Unit 11: Whole numbers: Multiplication	297
11.1 Count, add, multiply and divide	298
11.2 Factors and multiples	303
11.3 Use factors to multiply	305
11.4 Multiplication practice	306
11.5 Multiplication in real life	306
11.6 More calculations in real life	307

Learner Book Overview		
Sections in this unit	Content	Pages in Learner Book
1.1 Parts of wholes and parts of collections	Two meanings of fractions revisited	199 to 201
1.2 Equivalent fractions	Revision and consolidation of equivalent fractions	202 to 203
1.3 Parts of a measuring unit	A third meaning of fractions, and further consolidation of equivalent fractions	204 to 205
1.4 Combining, comparing and ordering fractions	Ordering fractions by writing them on the number line	206 to 207
1.5 Calculating a fraction of a quantity	Fraction parts of whole numbers	208
1.6 Addition and subtraction of fractions	Addition and subtraction of fractions, and improper fractions	209

CAPS time allocation	5 hours
CAPS page references	16 and 176 to 177

Mathematical background

Fractions are used for different purposes:

- They are used to describe parts of wholes, for example: “5 eighths of the floor is covered with tiles.”
- They are used to describe parts of collections and quantities. For example, if there are 120 people at a wedding and 72 of them are women, we can say 3 fifths of the people at the wedding are women. If somebody says “I spend 3 tenths of my income on housing” and she has an income of R8 000, she spends R2 400 on housing.
- They are used as parts of measuring units, for example: “The wall is 4 and 7 tenths of a metre long.”

Although two number symbols are used to write a fraction in the common fraction notation, for example 5 eighths is represented by the symbol $\frac{5}{8}$, any fraction is a single number. The fractions lie between the whole numbers on the number line.

Mixed numbers can be added and subtracted in two ways:

- by converting the mixed numbers to improper fractions
- by subtracting or adding the whole number parts and the fraction parts separately, replacing one fraction with a useful equivalent in the case of subtraction (if necessary).

1.1 Parts of wholes and parts of collections

Mathematical notes

Understanding fractions as part of units of measurement provides the foundation for understanding the decimal notation. It helps us to see fractions as “numbers between the whole numbers”, which we can represent on the number line. Decimal fractions are only introduced in Grade 6.

Teaching guidelines

Allow learners to discuss fraction names and provide opportunities for them to say the fraction names properly and fully: $\frac{7}{10}$ is 7 tenths, not “7 over 10”. If you let learners describe fractions like in the latter, you risk teaching the misconception that a fraction is one whole number over another whole number. It is not. Make sure learners know the difference between the numerator and the denominator. The denominator indicates the kind of fraction part, which depends on the number of equal parts into which the object or unit of measurements is divided.

When we use a number (e.g. 5 eighths) to indicate how long, in metres, a certain piece of string is, we think of a metre as divided into eight equal parts and the string being as long as five of these parts.

Ensuring that learners say the fraction names properly may help to combat the misconception described above. Asking learners to write fractions in words and to represent them with neat, quickly-made fraction strips are powerful ways of promoting understanding of fractions.

Notes on questions

In question 3 the logic for (a) and (b) is different to the logic for (c) and (d). In (a) and (b) the bigger the denominator, the smaller each part is, so one twelfth is smaller than one tenth, and so on. In (c) and (d) we must look at both the numerator and the denominator. Five parts out of six is bigger than four parts out of five, as it is closer to the whole. Drawing two fraction strips will help to illustrate this.

Answers

- $\frac{1}{9}$
 - I counted how many equal parts there are (i.e. 9) and then I counted the number of red parts (i.e. 1). So 1 out of 9 parts is red, which means $\frac{1}{9}$ of the strip is red.
- $\frac{2}{5}$
 - $\frac{4}{10}$
 - $\frac{1}{6}$
 - $\frac{4}{12}$
 - $\frac{1}{4}$
 - $\frac{7}{8}$
 - $\frac{1}{3}$
- $\frac{4}{10}$
 - $\frac{1}{5}$
 - $\frac{5}{6}$
 - $\frac{7}{8}$

UNIT
1
COMMON FRACTIONS

1.1 Parts of wholes and parts of collections







This yellow strip is divided into  seven equal parts.

Each part is one seventh of the whole strip.
The symbol for one seventh is $\frac{1}{7}$.

- This strip is also divided into  equal parts.
 - What part of this strip is red?
 - Describe in words what you did to decide on your answer for (a).

This strip is divided into 11 equal parts.

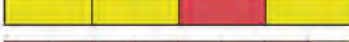
$\frac{3}{11}$ of the strip is red. 

- What part of each strip is red?
 - 
 - 
 - 
 - 
 - 
 - 
 - 
- Which is bigger in each case?

(a) $\frac{4}{12}$ or $\frac{4}{10}$	(b) $\frac{1}{6}$ or $\frac{1}{5}$
(c) $\frac{5}{6}$ or $\frac{4}{5}$	(d) $\frac{7}{8}$ or $\frac{6}{7}$

GRADE 5: MATHEMATICS [TERM 3] 199

Teaching guidelines

Before learners do question 6, refer to the second tinted passage on page 199 of the Learner Book. Make learners aware of the fact that the three red parts in the tinted passage are not together, but they still make 3 elevenths.

Take the class through the explanation in the tinted passage on page 200 before doing question 8. See if anybody offers the equivalent fraction. $\frac{1}{3}$ is more compelling because of the way the rectangle has been coloured in.

Notes on questions

It would be valuable to discuss question 8 thoroughly in class, once learners have responded to it individually. It will promote understanding of equivalent fractions.

Answers

4. (a) Jenny (b) $\frac{1}{6}$ is bigger than $\frac{1}{8}$; the same logic as in 3(a).
5. (a) $\frac{1}{12}$
(b) Agree; four of the twelve equal parts are red, and they make up $\frac{1}{3}$ of the rectangle. Learners may give different explanations of why they agree.
(c) Agree; even though the four red parts are not together they still make up four of the twelve parts of the rectangle, which is the same as $\frac{1}{3}$ of the rectangle. Learners may give different explanations of why they agree.
6. (a) Agree; once again there are four red squares (as in question 5).
(b) If we divide the rectangle into 3 equal parts, 4 of the small red blocks will fit into $\frac{1}{3}$ of the rectangle. This is the same question as 5(b), just perceptually different.
7. (a) Agree; in this case it is very easy to see the four blocks out of 12.
(b) The rectangle is divided into 12 equal parts and 4 of the small red blocks are four twelfths of the whole, but here it is very tempting to say $\frac{1}{3}$.
(c) Yes; it was just another way of saying $\frac{1}{3}$.
(d) Yes; different fractions can be used to describe the same part.
8. (a) Agree
(b) The rectangle is divided into 9 small blocks and 3 of the 9 blocks are coloured red.

4. Jenny eats $\frac{1}{6}$ of a loaf of bread, and Jill eats $\frac{1}{8}$ of the same loaf.

- (a) Who eats more bread?
(b) Explain how you know that.

5. (a) What part of this rectangle is yellow?

- (b) Do you agree or disagree that $\frac{1}{3}$ of this rectangle is red?

- (c) Explain your answer.



6. (a) Do you agree or disagree that $\frac{1}{3}$ of this rectangle is red?

- (b) Explain your answer.



7. (a) Do you agree or disagree that $\frac{4}{12}$ of this rectangle is red?

- (b) Explain your answer.

- (c) Do you still agree with your answers to question 5?

- (d) Is it true that $\frac{2}{6}$ of the rectangle is red?



Different fractions can be used to describe the same part of a whole. For example, the fractions $\frac{4}{12}$, $\frac{1}{3}$ and $\frac{2}{6}$ can all be used to state what part of the rectangle in question 7 is red.

Different fractions that describe the same quantity are called **equivalent fractions**.

8. (a) Do you agree or disagree that $\frac{3}{9}$ of this rectangle is red?

- (b) Explain your answer.



Teaching guidelines

Before learners do question 9, ask them what they can say about the four rectangles. They may be able to say immediately that the red and yellow take up equal space in the rectangles. If they do not say this immediately, ask them again after they have done (a) to (d). This is a nice visual representation of equivalent fractions.





Note that question 10 is a little different. The three quarters or three fourths are not so obviously displayed. The whole in (a) is bigger than the whole in (c).

When learners have finished question 11, go through the first tinted passage with the whole class. The information may seem repetitive, but must be stressed. Explain to them that in question 10, for example, there are four parts in the whole. In the fraction $\frac{3}{4}$, 4 is the denominator for the rectangles, and 3 is the numerator and tells us how many parts there are in this particular fraction. The tinted section at the bottom of the page reinforces this concept.



Answers

9. (a) $\frac{8}{20}$ or $\frac{2}{5}$ (b) $\frac{6}{15}$ or $\frac{2}{5}$ (c) $\frac{4}{10}$ or $\frac{2}{5}$ (d) $\frac{2}{5}$
10. (a) $\frac{3}{4}$ (b) $\frac{3}{4}$ (c) $\frac{3}{4}$
11. (a) No
 (b) A quarter of a bigger chunk is more than a quarter of a smaller chunk. The rectangles are different sizes.
12. (a) $\frac{1}{8}$
 (b) $\frac{3}{8}$

9. What part of each rectangle below is yellow?

(a)  (b)  (c)  (d) 

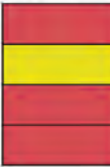
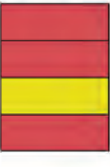
10. What part of each rectangle below is red?

(a)  (b)  (c) 

11. (a) Is $\frac{1}{4}$ of the rectangle in 10(a) equal to $\frac{1}{4}$ of the rectangle in 10(c)?
 (b) Explain your answer.

A fraction is a part of a whole. The "4" in $\frac{3}{4}$ is called the **denominator** of the fraction. It tells us what the size of the parts is and therefore how many parts it takes to make a whole. The "3" in $\frac{3}{4}$ is called the **numerator** of the fraction. It tells us how many parts there are in this fraction.

12. Mr Daniels packs apples in boxes. He wants to put the same number of apples in each of the boxes. He has enough apples to fill 8 boxes.

(a) What fraction of all of the apples is in each box? 

(b) What fraction of all of the apples is in three of the boxes? 

Each box contains one eighth of all the apples. The **denominator** is 8 in this case. There is $\frac{3}{8}$ of all of the apples in 3 of the boxes. The **numerator** is 3 – that is the number of the parts in the fraction.

GRADE 5: MATHEMATICS [TERM 3] 201

1.2 Equivalent fractions

Teaching guidelines

Remind learners again that the bigger the denominator, the smaller the part: one third ($\frac{1}{3}$) of a loaf of bread is a much bigger piece than $\frac{1}{9}$ of the loaf.

Learners should do the questions individually without help. Make sure that they understand what is asked in the different questions.

After questions 1 and 2, go through the tinted passage with the class and confirm that the quantity of cake remains the same, no matter into how many smaller parts you cut it.

Answers

- (a) $\frac{1}{3}$ (b) $\frac{1}{6}$ (c) $\frac{1}{9}$
(d) two sixths; three ninths; four twelfths
- (a) $\frac{1}{8}$ (b) $\frac{1}{12}$
(c) two eighths; three twelfths; four sixteenths

1.2 Equivalent fractions

1. A loaf of bread is cut into 3 equal parts.

- (a) What fraction of the whole loaf is each of these parts?
- (b) If you cut each of these smaller parts into two equal parts, what fraction of the loaf is each of these smaller parts?

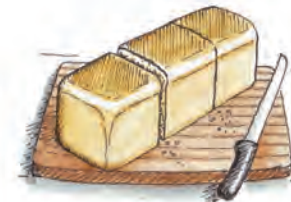

- (c) Dora cuts another loaf of bread into three equal parts. She wants smaller parts. So she cuts each of the parts into three equal parts. What fraction of the whole is each of these smaller parts?
- (d) In words, write three fractions that are equivalent to one third.

2. This cake is cut into four equal parts.

- (a) You cut each of the four parts into two equal parts. What fraction of the whole cake is each of these smaller parts?



- (b) Rosie has another cake. She cuts that cake also into four equal parts. She wants smaller parts. So she cuts each of the four parts into three equal parts. What fraction of the whole cake is each of these smaller parts?
- (c) In words, write three more fractions that are equivalent to one quarter.

The three fractions that you named as equivalent all describe the same quantity, namely one third in question 1 and one quarter in question 2. However, their denominators differ because in each case the fraction was cut up into smaller parts.

Notes on questions

In question 3 we have green strips with light and dark sections. The pink fraction strip helps us to measure these different sections, as well as each whole strip. Question 3(a) has been done for learners to get them started. By now they should know to count the length of the whole strip first.

In responding to question 3(a), some learners may describe the green strip as $\frac{3}{24}$. The light green strip in (a) is indeed $\frac{3}{24}$ as long as the pink strip, which is divided into 24 equal parts. However, the question requires expressing the light green strip as a fraction of the green strip (8 segments long), not of the pink strip. The light green strip in (a) is $\frac{3}{8}$ of the green strip – it forms part of the green strip.

Discussion of the fact that each light green strip on the diagrams can be expressed in two ways as a fraction can promote deeper understanding of fractions:

In question 3(a), $\frac{3}{8}$ of the green strip = $\frac{3}{24}$ of the pink strip.

In question 4 the notion of equivalent fractions is taken further. Sometimes more than one step is needed to find the answer.

In question 5, $\frac{5}{12}$ has no equivalent fraction within the range of fractions learners now work with, yet some learners may move ahead in their minds and state $\frac{10}{24}$. You may bring this to the attention of the whole class when they have all finished question 5, and ask the learners who gave this answer to explain their thinking.

Answers

3. (a) $\frac{3}{8}$ (b) $\frac{7}{10}$ (c) $\frac{5}{7}$ (d) $\frac{8}{11}$
 (e) $\frac{4}{6}$ (f) $\frac{8}{12}$ (g) $\frac{2}{3}$ (h) $\frac{6}{9}$
4. (a) True (b) False (c) True (d) True
 (e) True (f) True (g) True
5. (a) $\frac{5}{12}$ (also $\frac{10}{24}$; see “Notes on questions” above)
 (b) $\frac{3}{12}$ or $\frac{1}{4}$ (c) $\frac{3}{12}$ or $\frac{1}{4}$ (d) $\frac{6}{12}$ or $\frac{1}{2}$ (e) $\frac{4}{12}$ or $\frac{1}{3}$
 (f) $\frac{6}{12}$ or $\frac{1}{2}$ (g) $\frac{4}{12}$ or $\frac{1}{3}$ (h) $\frac{5}{12}$

3. $\frac{3}{8}$ of Strip (a) on the diagram below is light green. Use the divisions on the pink strip as a guide to find out what part of each green strip is light green.

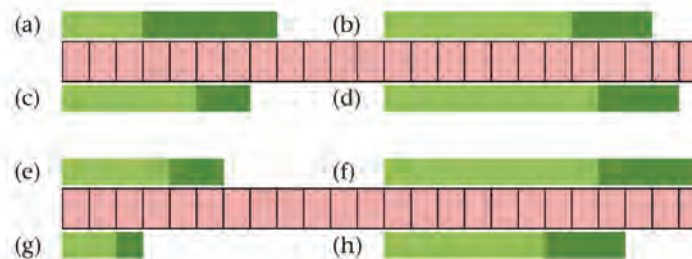

4. Which statements about the above strips are true and which are false?

- (a) $\frac{2}{3}$ of Strip (f) is light green. (b) $\frac{6}{8}$ of Strip (h) is light green.
 (c) $\frac{2}{3}$ of Strip (e) is light green. (d) $\frac{4}{6}$ of Strip (e) is light green.
 (e) $\frac{4}{6}$ of Strip (g) is light green. (f) $\frac{6}{9}$ of Strip (h) is light green.
 (g) $\frac{6}{9}$ of Strip (e) is light green.

5. What fraction parts of the circles are shaded? Write each answer in as many different ways as you can.

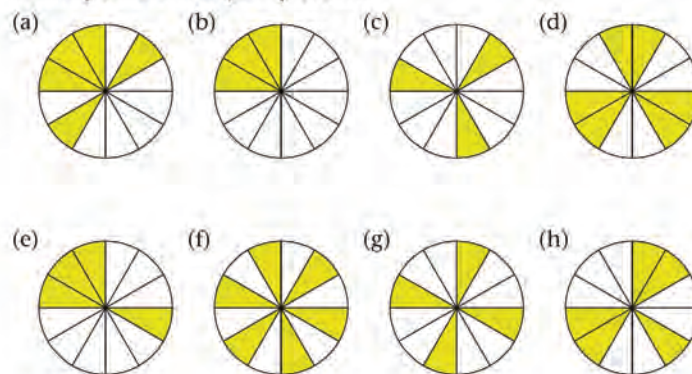

1.3 Parts of a measuring unit

Teaching guidelines

Question 1 is specifically intended to help learners make sense of addition of fractions. We call this “unit of measurement” the Brownstick, just to show it is something we have invented to help us measure. It is arbitrary (do not use this word with the learners). The important teaching point is that fractions help us to measure accurately.

Go through the tinted section of the page. The blue strip fits perfectly, so we have no problems there. But now there is the challenge of the red strip. Ask learners how they would measure the part that is longer than one Brownstick but shorter than two Brownsticks.

We can divide our Brownstick into equal fractions. Two possibilities are offered. The first example is division into tenths; the second is division into twelfths. The second one gives us an accurate yardstick for measuring: one and 5 twelfths of a Brownstick.

Notes on questions

Looking at question 1 the class have to identify the fraction parts in order to answer the questions. Question 1(c) can be answered by counting the fraction parts, or else by visualising moving the blue strip leftwards.

Answers

- (a) Red: 7 eighths of a Brownstick
Blue: 5 eighths of a Brownstick
- $1\frac{4}{8}$ of a Brownstick
- The two strips together are $1\frac{1}{2}$ Brownsticks long.

1.3 Parts of a measuring unit

You will now measure the length of coloured strips.
The Brownstick below will be your unit of measurement:



This blue strip is exactly 2 Brownsticks long:



The red strip below is longer than 1 Brownstick, but it is shorter than 2 Brownsticks.



You will use rulers that are divided into fraction parts of a Brownstick.
For example, the ruler below is divided into **tenths** of a Brownstick.



On the ruler below you can see that the red strip is **one and 5 twelfths** of a Brownstick long.



We can write the length in symbols as $1\frac{5}{12}$ of a Brownstick.

- (a) How long is each coloured strip below?



- (b) How long are these two strips together?
- (c) Are the two strips together longer or shorter than $1\frac{1}{2}$ Brownsticks?

Notes on questions

Questions 2 and 3 provide practice in adding fractions and experiences of equivalent fractions.

Although question 3(a) can be done without consciously thinking of division, it provides learners with an experience of a sharing situation involving fractions.

In question 4, notice that the Brownstick is divided into twelfths, but every second twelfth has a longer line, helping the visual perception of sixths.

Question 5 is practice in forming equivalent fractions.

Answers

2. (a) Blue: $\frac{3}{5}$ or $\frac{6}{10}$ of a Brownstick Red: $\frac{4}{10}$ or $\frac{2}{5}$ of a Brownstick
 Green: $\frac{2}{5}$ of a Brownstick Yellow: $\frac{3}{5}$ of a Brownstick
- (b) 1 Brownstick
 (c) 1 Brownstick
3. (a) $\frac{10}{10} = 1$. Accept either or both. (b) $\frac{5}{5} = 1$. Accept either or both.
 (c) $\frac{7}{10}$ (d) $\frac{4}{5}$
 (e) $\frac{11}{10} = 1\frac{1}{10}$. Accept either or both. (f) $\frac{7}{5} = 1\frac{2}{5}$. Accept either or both.
4. (a) Both are $1\frac{4}{6}$ of a Brownstick or $1\frac{8}{12}$ of a Brownstick long.
 (b) $\frac{2}{6}$ of a Brownstick or $\frac{4}{12}$ of a Brownstick
 (c) $1\frac{3}{12}$ of a Brownstick
5. (a) 2 twelfths (b) 4 twelfths
 (c) 2 tenths (d) 6 eighths

2. (a) How long is each of the coloured strips below?



- (b) How long are the blue and red strips together?
 (c) How long are the green and yellow strips together?

3. Calculate:

(a) $\frac{6}{10} + \frac{4}{10}$	(b) $\frac{3}{5} + \frac{2}{5}$
(c) $\frac{3}{10} + \frac{4}{10}$	(d) $\frac{2}{5} + \frac{2}{5}$
(e) $\frac{7}{10} + \frac{4}{10}$	(f) $\frac{4}{5} + \frac{3}{5}$

4. (a) How long is each coloured strip below?



- (b) How long will each piece be, if the red strip is divided into 5 equal pieces?
 (c) Imagine that part of the green strip is painted red. The painted part is $\frac{5}{12}$ of a Brownstick long. How long is the piece that remains green?
5. (a) How many twelfths of a Brownstick is the same length as one sixth of a Brownstick?
 (b) How many twelfths of a Brownstick is the same length as one third of a Brownstick?
 (c) How many tenths of a Brownstick is the same length as one fifth of a Brownstick?
 (d) How many eighths of a Brownstick is the same length as three quarters of a Brownstick?

1.4 Combining, comparing and ordering fractions

Mathematical notes

In this unit we extend the interpretation of **fractions as measures**, which we have just dealt with in Unit 1.3, to develop learners' understanding of **fractions as numbers**. Questions 1 to 4 are a very simple introduction.

Notes on questions

In question 4 learners must recognise four eighths as equivalent to one half.

In question 5(a) attention must be paid to the numerator, the denominator as well as equivalent fractions. The class might need your help here, but let them try first. In question 5(b) learners must realise when both the numerator and denominator are large, the fraction is larger. There is an easy visual pattern here.

Ask learners in question 6 how they worked out their answers here. Did they draw a fraction strip? Or did they use some other way?

Answers

- $\frac{5}{10}; \frac{6}{10}; \frac{7}{10}; \frac{8}{10}; \frac{9}{10}; 1; 1\frac{1}{10}; 1\frac{2}{10}; 1\frac{3}{10}; 1\frac{4}{10}; 1\frac{5}{10}; 1\frac{6}{10}; 1\frac{7}{10}; 1\frac{8}{10}; 1\frac{9}{10}; 2$
- $\frac{1}{8}; \frac{2}{8}; \frac{3}{8}; \frac{4}{8}; \frac{5}{8}; \frac{6}{8}; \frac{7}{8}; 1; 1\frac{1}{8}; 1\frac{2}{8}; 1\frac{3}{8}; 1\frac{4}{8}; 1\frac{5}{8}; 1\frac{6}{8}; 1\frac{7}{8}; 2$
- $\frac{1}{5}; \frac{2}{5}; \frac{3}{5}; \frac{4}{5}; 1; 1\frac{1}{5}; 1\frac{2}{5}; 1\frac{3}{5}; 1\frac{4}{5}; 2; 2\frac{1}{5}; 2\frac{2}{5}; 2\frac{3}{5}; 2\frac{4}{5}; 3$
 - $\frac{1}{8}; \frac{2}{8}; \frac{3}{8}; \frac{4}{8}; \frac{5}{8}; \frac{6}{8}; \frac{7}{8}; 1; 1\frac{1}{8}; 1\frac{2}{8}; 1\frac{3}{8}; 1\frac{4}{8}; 1\frac{5}{8}; 1\frac{6}{8}; 1\frac{7}{8}; 2$
- $2; 1\frac{4}{5}; 1\frac{3}{5}; 1\frac{2}{5}; 1\frac{1}{5}; 1; \frac{4}{5}; \frac{3}{5}; \frac{2}{5}; \frac{1}{5}; 0$
 - $3; 2\frac{7}{8}; 2\frac{6}{8}; 2\frac{5}{8}; 2\frac{4}{8}; 2\frac{3}{8}; 2\frac{2}{8}; 2\frac{1}{8}; 2; 1\frac{7}{8}; 1\frac{6}{8}; 1\frac{5}{8}; 1\frac{4}{8}$
- $\frac{1}{6}; \frac{1}{3}; \frac{1}{2}; \frac{2}{3}; \frac{5}{6}$
 - $\frac{2}{3}; \frac{4}{5}; \frac{5}{6}; \frac{7}{8}; \frac{8}{9}; \frac{10}{11}$
- $\frac{5}{9}$ is bigger than a half
 - $\frac{3}{7}$ is smaller than a half
 - $\frac{6}{12}$ is equal to a half
 - $\frac{5}{11}$ is smaller than a half

1.4 Combining, comparing and ordering fractions

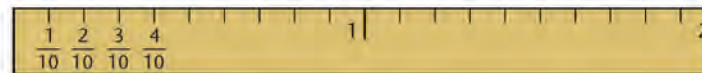

- Numbers are shown at the first four marks on the above ruler. Write the numbers that can be written at the other marks from left to right in your book. Start at $\frac{5}{10}$ and write the numbers until you reach 2.

When you write the numbers $\frac{1}{10}; \frac{2}{10}; \frac{3}{10}; \frac{4}{10}; \frac{5}{10} \dots$ we may say you **count in tenths**.

- Start at $\frac{1}{8}$ and count in eighths until you reach 2. Write the numbers down as you would write them on an eighths-ruler.



- Write the numbers.
 - Count in fifths from $\frac{1}{5}$ until you reach 3.
 - Count in eighths from $\frac{1}{8}$ until you reach 2.

You can count backwards in fractions too, for example $1; \frac{8}{9}; \frac{7}{9}; \frac{6}{9}; \frac{5}{9}; \frac{4}{9} \dots$

- Write the numbers in each case.
 - Count backwards in fifths from 2, until you reach 0.
 - Count backwards in eighths from 3, until you reach $1\frac{1}{2}$.

- Write these numbers from the smallest to the biggest:

(a) $\frac{1}{2}; \frac{5}{6}; \frac{2}{3}; \frac{1}{3}; \frac{1}{6}$ (b) $\frac{10}{11}; \frac{4}{5}; \frac{7}{8}; \frac{2}{3}; \frac{8}{9}; \frac{5}{6}$

- Say whether these fractions are bigger than, smaller than or equal to a half.

(a) $\frac{5}{9}$ (b) $\frac{3}{7}$ (c) $\frac{6}{12}$ (d) $\frac{5}{11}$

Answers

7. (a) $\frac{2}{4}; 1\frac{1}{4}; 1\frac{2}{4}; 1\frac{3}{4}; 2\frac{1}{4}; 2\frac{2}{4}$
 (b) $\frac{3}{6}; \frac{4}{6}; \frac{5}{6}; 1\frac{1}{6}; 1\frac{2}{6}; 1\frac{3}{6}; 1\frac{4}{6}; 1\frac{5}{6}; 2\frac{1}{6}; 2\frac{2}{6}; 2\frac{3}{6}; 2\frac{4}{6}$
 (c) $\frac{2}{8}; \frac{3}{8}; \frac{4}{8}; \frac{5}{8}; \frac{6}{8}; \frac{7}{8}; 1\frac{1}{8}; 1\frac{2}{8}; 1\frac{3}{8}; 1\frac{4}{8}; 1\frac{5}{8}; 1\frac{6}{8}; 1\frac{7}{8}; 2\frac{1}{8}; 2\frac{2}{8}; 2\frac{3}{8}; 2\frac{4}{8}; 2\frac{5}{8}$
 (d) $\frac{5}{12}; \frac{6}{12}; \frac{8}{12}; \frac{9}{12}; \frac{11}{12}; 1\frac{2}{12}; 1\frac{8}{12}; 1\frac{9}{12}; 1\frac{11}{12}; 2\frac{2}{12}; 2\frac{3}{12}; 2\frac{5}{12}$

8. $\frac{1}{4} = \frac{2}{8} = \frac{3}{12}$
 $\frac{2}{4} = \frac{3}{6} = \frac{4}{8} = \frac{6}{12}$
 $\frac{4}{6} = \frac{8}{12}$
 $\frac{3}{4} = \frac{6}{8} = \frac{9}{12}$
 $1\frac{1}{6} = 1\frac{2}{12}$
 $1\frac{1}{4} = 1\frac{2}{8} = 1\frac{3}{12}$
 $1\frac{2}{4} = 1\frac{3}{6} = 1\frac{4}{8}$
 $1\frac{4}{6} = 1\frac{8}{12}$
 $1\frac{3}{4} = 1\frac{6}{8} = 1\frac{9}{12}$
 $2\frac{1}{6} = 2\frac{2}{12}$
 $2\frac{1}{4} = 2\frac{2}{8} = 2\frac{3}{12}$
 $2\frac{2}{4} = 2\frac{3}{6} = 2\frac{4}{8}$

7. Draw four vertical number lines like these in your book. Use the lines in your book as the horizontal lines. Draw the short marks on the lines as they are indicated below. Fill in the missing numbers at the marks.

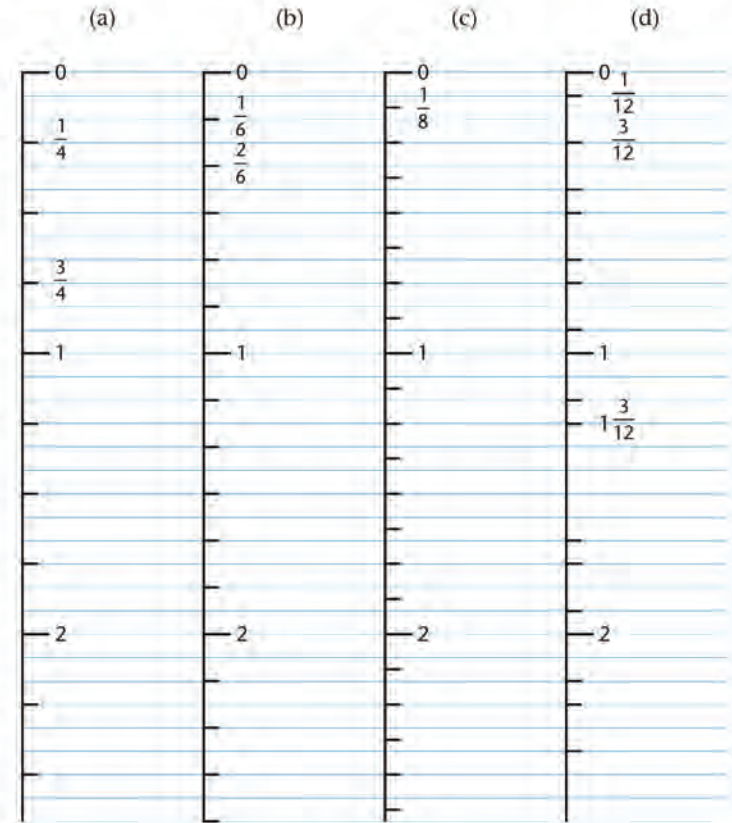

8. Did you notice equivalent fractions as you counted? Make a list of all the equivalent fractions that you see. Compare your list with the lists of your classmates.

1.5 Calculating a fraction of a quantity

Mathematical notes

This work develops the foundation for multiplication with fractions, which learners will engage with in Grade 7. You can ask the class how they got their answers to questions 3, 4 and 5. Correct any mistakes, but simply comment on good methods as “correct”. *Do not teach any formulas for solving such problems.* Hopefully learners will show how they used the answers to questions 1(a), (b) and (c) to work out answers to questions 3, 4 and 5.

Answers

- $5; 5\frac{1}{2}; 6; 6\frac{1}{2}; 8; 11; 19$
 - $10; 11; 12; 13; 16; 22; 38$
 - $10; 11; 12; 13; 16; 22; 38$
- They produce the same answers.
 - They are equivalent fractions.
- 28 learners
- 40 learners
- 30 circles

1.5 Calculating a fraction of a quantity

1. Copy the tables and complete them.

(a)

Number	50	55	60	65	80	110	190
$\frac{1}{10}$ of the number							

(b)

Number	50	55	60	65	80	110	190
$\frac{2}{10}$ of the number							

(c)

Number	50	55	60	65	80	110	190
$\frac{1}{5}$ of the number							

- What did you notice about $\frac{2}{10}$ and $\frac{1}{5}$ when you did question 1?
 - Can you explain that?
- There are 35 learners in Mr Nkebe’s class. $\frac{4}{5}$ of the class takes part in sport. How many learners is that?
- Mrs Dube complains that one fifth of her class is absent with flu. There are 8 learners in her class with flu. How many learners are in her class?
- If this is two fifths of all the circles, how many circles are there altogether?

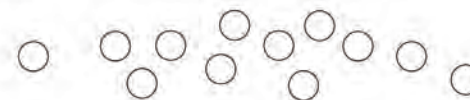

1.6 Addition and subtraction of fractions

Teaching guidelines

Please see “Mathematical notes” on the next page.

Question 1 is intended to make learners aware of a challenge, and the expectation should not be that they manage to produce an answer now. Some learners may come up with the idea of rewriting $3\frac{1}{11}$ as $2\frac{12}{11}$, but this will not necessarily happen.

Once learners have engaged with the question for about 5 minutes, you may write the following questions on the board. Ask learners to answer the questions individually; then resume their discussions about question 1.

- How many elevenths are equal to 1 whole?
- How many elevenths are equal to 2 wholes?
- How many elevenths are equal to 3 wholes?
- How many elevenths are equal to $3\frac{1}{11}$ wholes?

Allow learners to engage with question 1 for another 5 to 10 minutes, then ask them to let go of it for now and proceed to question 2. You may tell them that by doing question 2 they may get an idea of how to meet the challenge that question 1 presented them with.

After learners have completed question 2, let them engage with question 1 again, individually this time, for about 5 minutes. Then demonstrate to them that it will help to rewrite $3\frac{1}{11}$ as $2\frac{12}{11}$, or to rewrite both fractions in the following way:

$$3\frac{1}{11} = \frac{33}{11} + \frac{1}{11} = \frac{34}{11} \quad \text{and} \quad 1\frac{5}{11} = \frac{11}{11} + \frac{5}{11} = \frac{16}{11}$$

Answers

1. and 2. Yes, first subtract 1 from 3 and then subtract 1 eleventh from 5 elevenths.

3. (a) $\frac{15}{7}$ or $2\frac{1}{7}$ (b) $\frac{35}{8}$ or $4\frac{3}{8}$ (c) $\frac{15}{12}$ or $1\frac{3}{12}$ or $1\frac{1}{4}$ (d) 4

(e) $\frac{9}{11}$ (f) $5\frac{5}{6}$ (g) $\frac{9}{9}$ or 1 (h) $\frac{2}{3}$

4. (a) $\frac{20}{12}$ or $1\frac{8}{12}$ or $1\frac{3}{4}$ (b) $1\frac{8}{9}$ (c) $3\frac{3}{7}$

(d) Let learners share their explanations. You may use some of their explanations to further consolidate subtraction with mixed numbers.

(e) $\frac{8}{5} = 1\frac{3}{5}$

1.6 Addition and subtraction of fractions

- Discuss with a classmate what you will do if you have to subtract $1\frac{5}{11}$ from $3\frac{1}{11}$.
- Do you agree that it is easy to subtract $1\frac{1}{11}$ from $2\frac{5}{11}$? Discuss this with a classmate.

You can subtract 1 from 2 and $\frac{1}{11}$ from $\frac{5}{11}$, so

$$2\frac{5}{11} - 1\frac{1}{11} = (2 - 1) + (\frac{5}{11} - \frac{1}{11}) = 1\frac{4}{11}$$

Remember that $3\frac{1}{11} = 2 + 1\frac{1}{11} = 2 + \frac{12}{11}$... and that makes it easier to do calculations such as the one in question 1!

$$\text{So, } 3\frac{1}{11} - 1\frac{5}{11} \rightarrow 3 - 1 \rightarrow 2 + \frac{1}{11} - \frac{5}{11} \rightarrow 1 + \frac{11}{11} + \frac{1}{11} - \frac{5}{11} \rightarrow 1 + \frac{12}{11} - \frac{5}{11} = 1 + \frac{7}{11} = 1\frac{7}{11}$$

3. Now, calculate these:

(a) $\frac{3}{7} + \frac{3}{7} + \frac{3}{7} + \frac{3}{7} + \frac{3}{7}$ (b) $\frac{7}{8} + \frac{7}{8} + \frac{7}{8} + \frac{7}{8} + \frac{7}{8}$

(c) $\frac{7}{12} + \frac{7}{12} + \frac{7}{12} - \frac{5}{12} - \frac{1}{12}$ (d) $2\frac{7}{8} + \frac{5}{8} + \frac{3}{8} + \frac{1}{8}$

(e) $3\frac{5}{11} - 2\frac{7}{11}$ (f) $4\frac{1}{6} + 2\frac{5}{6} - \frac{7}{6}$

(g) $\frac{5}{9} + \frac{5}{9} - \frac{1}{9}$ (h) $2\frac{1}{3} - 1\frac{2}{3}$

4. Calculate:

(a) $\frac{5}{12} + \frac{5}{12} + \frac{5}{12} + \frac{5}{12}$ (b) $2 - \frac{1}{9}$

(c) $3\frac{1}{7} + \frac{6}{7} - \frac{4}{7}$

(d) How will you subtract $3\frac{7}{12}$ from $5\frac{1}{12}$?

Lindi does it like this: $5\frac{1}{12} - 3 \rightarrow 2\frac{1}{12} - \frac{7}{12} \rightarrow 1\frac{13}{12} - \frac{7}{12} = 1\frac{6}{12}$

(e) Now do this one: $7\frac{2}{5} - 5\frac{4}{5}$.

Mathematical notes

Mixed numbers can be added and subtracted in the two ways described below:

- By subtracting or adding the whole number parts and the fraction parts separately, replacing one fraction with a useful equivalent in the case of subtraction if necessary (similar to what is done in subtraction of whole numbers), for example:

$$5\frac{7}{20} - 2\frac{13}{20} = 4\frac{27}{20} - 2\frac{13}{20} = 2\frac{14}{20}$$

- By converting the mixed numbers to improper fractions, for example:

$$5\frac{7}{20} - 2\frac{13}{20} = \frac{107}{20} - \frac{53}{20} = \frac{54}{20} = 2\frac{14}{20}$$

Notes on questions

In question 8 some learners may be trapped into thinking the answer is three quarters of 10. It is not.

To help learners who fall into this trap, you can draw a number line that is 10 units long, with each unit subdivided into quarter-units, on the board. Ask learners to count how many sections of three quarters each there are on this line.

You can also suggest that they count up in three quarters:

$$\frac{3}{4} \quad 1\frac{1}{2} \quad 2\frac{1}{4} \quad 3 \quad 3\frac{3}{4} \quad 4\frac{1}{2} \quad 5\frac{1}{4} \quad 6 \quad 6\frac{3}{4} \quad 7\frac{1}{2} \quad 8\frac{1}{4} \quad 9 \quad 9\frac{3}{4}$$

and there is one quarter metre material left over.

Answers

5. (a) Blue: $\frac{2}{11}$ or $\frac{4}{22}$ Red: $\frac{3}{11}$ or $\frac{6}{22}$ White: $\frac{6}{11}$ or $\frac{12}{22}$
 (b) Blue: $\frac{4}{12}$ or $\frac{1}{3}$ Red: $\frac{4}{12}$ or $\frac{1}{3}$ White: $\frac{4}{12}$ or $\frac{1}{3}$; or perhaps even $\frac{8}{24}$
 (c) Blue: $\frac{3}{10}$ or $\frac{6}{20}$ Red: $\frac{5}{10}$ or $\frac{1}{2}$ White: $\frac{2}{10}$ or $\frac{1}{5}$
6. (a) $\frac{11}{11} = 1$ (b) $\frac{8}{11}$
7. (a) $\frac{1}{7}$ (b) $\frac{4}{7}$ (c) $\frac{5}{7}$ (d) $\frac{7}{7} = 1$
 (e) $\frac{8}{7} = 1\frac{1}{7}$ (f) $\frac{9}{7} = 1\frac{2}{7}$ (g) $1\frac{6}{7}$ (h) $2\frac{5}{7}$
8. He can make 13 flags. ($\frac{1}{4}$ m of material will be left over.)
9. She will have $2\frac{6}{8}$ m $-$ $\frac{5}{8}$ m $=$ $2\frac{1}{8}$ m lace left.

5. Look at the strips below. What fraction of each strip is blue, what fraction is red and what fraction is white?

Name each of the fractions in more than one way.

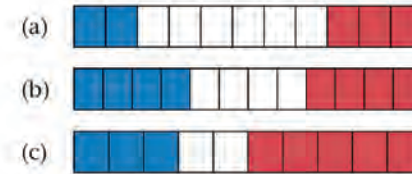

6. Calculate the following:

(a) $\frac{2}{11} + \frac{6}{11} + \frac{3}{11}$

(b) $1 - \frac{3}{11}$

7. What number is missing in each of these number sentences?

(a) $\dots + \frac{2}{7} = \frac{3}{7}$

(b) $\frac{2}{7} + \frac{2}{7} = \dots$

(c) $\frac{3}{7} + \frac{2}{7} = \dots$

(d) $\frac{5}{7} + \frac{2}{7} = \dots$

(e) $\frac{6}{7} + \frac{2}{7} = \dots$

(f) $1 + \frac{2}{7} = \dots$

(g) $\dots + \frac{2}{7} = 2\frac{1}{7}$

(h) $\dots + \frac{2}{7} = 3$

8. Leon uses 3 quarters of a metre of material to make one flag. How many flags can he make if he has 10 m of material available?
9. Mary has $2\frac{3}{4}$ m of lace. Her friend, Sethu needs $\frac{5}{8}$ m of that lace. How many metres will Mary have left if she agrees to give $\frac{5}{8}$ m to Sethu?

Learner Book Overview		
Sections in this unit	Content	Pages in Learner Book
2.1 Models of kilograms and grams	Developing a sense of how heavy 1 g and 1 kg are	211 to 212
2.2 Estimating and measuring mass	Choosing appropriate instruments and units; estimating mass	212 to 214
2.3 The relationship between grams and kilograms	Converting between grams and kilograms; ordering objects by mass	214 to 215
2.4 Counting in grams and kilograms, and reading scales	Reading scales in grams and kilograms	215 to 216
2.5 Solving problems about mass and quantity	Solving problems using mass as a context	217

CAPS time allocation	5 hours
CAPS page references	26 and 178 to 180

Mathematical background

Length, mass, area, capacity and volume are different properties of objects. Length, area, capacity and volume are called **spatial measures**. We can often see how much space something takes up, how much area it covers, or what length something is.

Mass is not a spatial measure. It is called a **physical measure**. The mass of an object is the property that we feel in our hands – we say the object feels heavy, or not very heavy. From experience, we can remember how heavy a bucket of water is, but we cannot always guess how heavy an object is by looking at its size. Young learners often assume that the bigger something is, the heavier it must be. A small piece of iron may, however, be much heavier than a large piece of plastic foam; this tells us that the density of iron is greater than the density of plastic foam.

The heaviness of an object is really the force of gravity with which the object and the Earth pull on each other. We can measure the heaviness of an object on an instrument such as a bathroom scale. The scale is marked in grams and/or kilograms and so we can report the **mass** of the object: we can report that a brick has a mass of 1 kg or that Andile has a mass of 60 kg. A number (1 kg) for the mass of a brick is useful, for example if we need to calculate how many bricks we can safely load onto a 1-ton bakkie.

As explained in Term 2 Unit 4: *Length*, learners go through four stages when learning to measure: (1) identifying and understanding the property they are measuring; (2) comparing and ordering examples of a particular measure; (3) using informal or non-standard units to measure; (4) using formal or standard units to measure.

In Grade 5 learners work with standard units (grams and kilograms) when measuring mass. They need time to practise reading the scales of the measuring instruments (see Section 2.4).

Resources

We suggest that you read through the entire unit before you start teaching it and draw up a checklist of the resources that you will need for each lesson.

2.1 Models of kilograms and grams

Mathematical notes

Learners should develop a good sense of how much 1 kg is and how much 1 g is. This will help them to make sensible estimates of the mass of objects before measuring. Working with a balance scale can help to develop learners' sense of how heavy 1 kg and 1 g are.

The mass of a cube of water, $1\text{ cm} \times 1\text{ cm} \times 1\text{ cm}$ (i.e. 1 cm^3) is 1 g. (Scientists defined the gram very strictly: the water must be pure, and at a temperature of $4\text{ }^\circ\text{C}$. Why $4\text{ }^\circ\text{C}$? It is because water becomes less dense at $3\text{ }^\circ\text{C}$, $2\text{ }^\circ\text{C}$, and so on, and at $0\text{ }^\circ\text{C}$ it is ice and it floats on the rest of the water because ice is less dense than water.)

Empty plastic bags also have mass, so the small bag of water will have a mass of a little more than 1 g and the large bag of water will have a mass of a little more than 1 kg. Although all measurements are approximate, they are close enough for learners to get a sense of how heavy 1 g is and how heavy 1 kg is. Because the units that learners will make are not exactly 1 kg, nor exactly 1 g, it is important to always say *about* 1 kg or *about* 1 g.

Resources and teaching guidelines

Organise the following for each learner before you teach this section:

- Clear ziplock bags that hold 1 ℓ.
If you cannot get ziplock bags, you can use 1 ℓ plastic bottles. These will also have a mass of a bit more than 1 kg when they are filled with water, but they will still give learners a sense of how heavy 1 kg is.
- Very small bags that can hold 1 ml (20 drops of water). You could also use the small bags that banks use to hold coins. Alternatively, use bottle tops from cooldrink bottles or beer bottles. Their mass is between 2 g and 3 g. Adjust the activities accordingly.

You can use the photograph and the tinted text on page 212 of the Learner Book as a guide to demonstrate to learners how to make a simple balance scale. (Hint: Tape down the learners' pencils on their desks with masking tape, or use clay or sticky putty.)

Let learners use any light objects that are available. They can substitute nails, clothes pegs, etc. for the objects mentioned in the Learner Book.

Notes on questions

The aim of questions 2 and 3 is for learners to get a sense of the mass of 1 g, how heavy or how light it is. They can then use this to estimate the mass of other objects. A gram is very light and it is therefore very difficult to develop a sense of its mass. Learners can use other everyday objects such as a clothes peg or a pen or a box of matches to get a sense of the mass of objects in grams.

UNIT

2

MASS

2.1 Models of kilograms and grams

The **mass** of an object tells you how *heavy* or *light* the object is.

Everything we can touch has mass, even the tiniest thing. Sometimes our instruments cannot measure mass accurately enough and the scale may show a reading of zero. A reading of zero mass on one scale just means we need a better instrument to measure with.

The **standard unit** of measurement for mass is the **kilogram (kg)**. 1 ℓ of water has a mass of about 1 kg.

Very light objects are measured in **grams (g)** or fractions of grams. 20 drops of water have a mass of 1 g.

1. Make your own 1 kg mass and 1 g mass.

- (a) Fill a clear plastic bag with 1 ℓ of water.
- (b) Fill another small plastic bag with 20 drops of water.



If you ignore the mass of the plastic, you can use these bags to estimate the mass of other objects.

2. Make a balance scale to measure the mass of light objects.

- (a) Use your pencil, ruler and two identical pieces of cardboard or little boxes. Put the ruler over the pencil at the middle of the ruler. Put the cardboard pieces or boxes on the ruler on either side of the pencil. They must be the same distance away from the pencil. But even more important, the scale must balance, and one side must not dip down and the other dip up before you start using it.

Answers

Learners' answers may differ from those given below because different paper clips, pens, erasers and bottle tops have different masses. Also, the balance scale will not be very accurate.

3. (a) About 2 paper clips (b) $\frac{1}{2}$ g
(c) About 6 g to 12 g (d) Less than 10 g to over 30 g
(e) Tops of 1 l and 2 l plastic bottles are usually about 3 g. Metal bottle tops (from glass cooldrink and beer bottles) and the plastic tops of 500 ml or smaller plastic bottles usually have a mass of about 2 g.
(f) Learners' answers will differ. Some objects with a mass of 1 g are a 10c coin, a dried butter bean, and a large button.
(g) Learners' answers will differ. Approximate masses of other light objects: empty matchbox, about 3 g; full box of matches, about 10 g; wooden clothes peg, about 5 g to 8 g; ballpoint pen, about 5 g to 12 g; key, about 10 g to 12 g.

2.2 Estimating and measuring mass

Mathematical notes

Learners can use their 1 kg models to estimate masses in kilograms. They can use their 1 g and 1 kg models to choose appropriate units of mass and linked to this, appropriate scales.

The word "scale" in English has two meanings: we talk of the *scale* marked on a ruler – the millimetre and centimetre markings; and we talk of a *bathroom scale* – an instrument that people stand on to weigh themselves.

Resources and teaching guidelines

It is important that these activities are *done practically*. Make a checklist of all the apparatus required in Section 2.2. Arrange to bring all the necessary items to class.

Notes on questions

When learners do question 4(b) on page 213 of the Learner Book, check that they know that they must stand directly in front of the dial. If they stand too far to the right or left of the dial, they will get a wrong reading.

In question 4(c) on page 213 of the Learner Book you might need to help learners decide on an appropriate scale for their graphs, and to think through what to do about masses that are less than 1 kg.

- (b) Put your little bag with a mass of 1 g (20 drops of water) on one side of your balance scale. You can now use your scale to estimate different masses. How are you going to do this? Discuss this with the class.



3. Use the balance scale you made to estimate the mass of the following objects. Work with a classmate to combine your 1 g bags.

- (a) How many paper clips balance the mass of 1 g?
(b) Estimate the mass of a paper clip.
(c) Estimate the mass of a ballpoint pen.
(d) Estimate the mass of an eraser.
(e) Estimate the mass of a bottle top.
(f) Find other objects that you think have a mass of about 1 g. Test your estimates using your balance scale.
(g) Find objects that you think have a mass of about 5 g. Test your estimates using your balance scale.

You can make more gram models. For example, fill another small plastic bag with 5×20 drops of water to make a model of about 5 g. Make one for 10 g also. Remember to adjust your estimates, since the plastic bags also have mass!

2.2 Estimating and measuring mass

A bathroom scale measures in kilograms. It is not accurate enough to measure differences in mass that are less than half a kilogram.

A bathroom scale usually measures objects that vary between a mass of about 1 kg and 120 kg.

Cooks and bakers use kitchen scales to measure small quantities in grams and kilograms.

A kitchen scale usually weighs amounts from a few grams to between 2 and 5 kg. 1 kg is the same mass as 1 000 g.

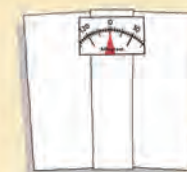

In question 5 learners could compare a cup or half a cup of these substances using a mass meter or a balance scale. Learners could also experiment with pouring some liquid soap into water and seeing whether it rises to the surface of the water or sinks to the bottom. They could test oil and liquid soap in the same way.

Answers

- (a) kilograms (b) grams (c) grams (d) grams
- (a) Kitchen scale (b) Kitchen scale (c) Bathroom scale
- See the answers to question 3 in Section 2.1.
- (a) Learners' estimates will differ because there are different stacks of books, schoolbags, pairs of shoes, bricks (often 2 kg to 4 kg) and potted plants.
(b) Learners' estimates will differ.
(c) Learners will probably make a bar graph. The bar graphs will differ from class to class. Learners should give the graph a heading and label the axes.

Mass of objects

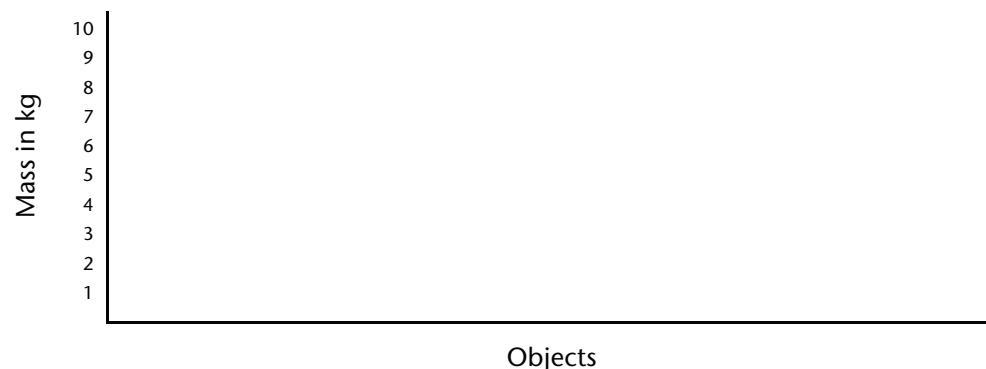

- You want learners to realise that they can only compare masses if they take equal quantities of each substance!
 - It depends how much sugar and how much rice we are comparing. If we fill tins of the same size with sugar and rice, their masses will be similar.
 - A tin of sand is heavier than a same-sized tin of sugar.
 - Yes, for same amounts
 - Yes, for same amounts
 - Yes, for same amounts

- Would you use grams or kilograms to talk about the mass of the following?
 - an adult goat (b) a mouse
 - a pencil (d) the butter used for baking a cake
- Would you use a kitchen scale or a bathroom scale to measure the following?
 - sugar for baking a cake
 - a thick letter
 - your own mass
- If you have an electronic kitchen scale, use it to check some of your estimates in question 3 on the previous page.
- (a) Estimate the mass of each of the following objects. Use your 1 l bag of water to help you to estimate.
 - a stack of books
 - a schoolbag
 - a pair of shoes
 - a brick
 - a potted plant
 (b) Use a bathroom scale to check your estimates.
(c) Make a graph of the measurements.
- Say what you think.
 - Is sugar heavier than rice?
 - Is sand heavier than sugar?
 - Is peanut butter heavier than butter?
 - Is liquid soap heavier than water?
 - Is oil heavier than liquid soap?
 How could you test your ideas? Discuss this with the class.

If we work with estimates in measurements, our answers must always say "about so much". We say that this is the **approximate measurement**.

If we want to compare the mass of different things, we have to make sure we compare equal amounts of the things.

Answers

6. (a) Learners' estimates will differ.
 (b) and (c) Water: about 250 g or $\frac{1}{4}$ kg Sand: about 375 g or $\frac{375}{1000}$ kg
 Liquid soap: about 500 g or $\frac{1}{2}$ kg Flour: about 130 g or $\frac{130}{1000}$ kg
 Clay or play dough: about 375 g or $\frac{375}{1000}$ kg
7. Learners' answers will differ. There are many possible answers.

2.3 The relationship between grams and kilograms

Mathematical notes

In the Intermediate Phase learners only work with grams and kilograms.

Learners can learn the conversion factors off by heart. However, they may sometimes forget them and use an incorrect conversion factor. It may be better for learners to understand how the relationship between metric units works in general.

In our base-ten place value system, each unit of a higher power is ten times the value of an adjacent unit of a lower power. 10 units (ones) make 1 ten; 10 tens make 1 hundred; 10 hundreds make 1 thousand, etc. The metric system also works with groupings or powers of tens. This is why, since the 1790s, it is called the decimal metric system. Page 143 of the Learner Book shows a table of the standard metric units for measuring length. Such units (kilo-, hecto-, deca-, deci-, etc.) also exist for measuring mass and capacity/volume.

Teaching guidelines

kilogram (kg)	hectogram	decagram	gram (g)	decigram	centigram	milligram (mg)

Learners can use a table like the one above to do conversions. They simply work as follows:

- They write the number in the correct column.
- They mark the unit they are converting to.
- If converting from a unit of a higher power to a unit of a lower power, they multiply by 10 each time they move to the next unit of a lower power, for example $25 \text{ kg} = (25 \times 10 \times 10 \times 10) \text{ g} = 25\,000 \text{ g}$.
- If converting from a unit of a lower power to a unit of a higher power, they divide by 10 each time they move to the next unit of a higher power, for example $4\,000 \text{ g} = (4\,000 \div 10 \div 10 \div 10) \text{ kg} = 4 \text{ kg}$, and $500 \text{ g} = (500 \div 10 \div 10 \div 10) \text{ kg} = \frac{5}{10} \text{ kg} = \frac{1}{2} \text{ kg}$.

6. (a) Estimate the mass, in grams, of a cupful of each of the following things. Use the same cup each time.

- water
- sand
- liquid soap
- flour
- clay or play dough

(b) Use a kitchen scale to check your estimates.

(c) Write your mass measurements as fractions of kilograms.

7. Which of the objects in question 4 were too light to measure accurately on the bathroom scale? Measure them again on a kitchen scale and write down their measurements.

A cupful of water (about 250 ml) without the cup has a mass of about 250 g. This is the same as $\frac{250}{1000}$ or one quarter of a kilogram.

2.3 The relationship between grams and kilograms

$$1\,000 \text{ g} = 1 \text{ kg} = 1\,000 \text{ g}$$

$$500 \text{ g} + 500 \text{ g} = 1\,000 \text{ g}, \text{ so } 500 \text{ g} = \frac{1}{2} \text{ kg}$$

$$250 \text{ g} + 250 \text{ g} + 250 \text{ g} + 250 \text{ g} = 1\,000 \text{ g}, \text{ so } 250 \text{ g} = \frac{1}{4} \text{ kg}$$

1. Read the mass of each grocery item and complete the table on the next page.



If you want learners to be able to work with all the metric units for mass between milli- and kilo-, then it is useful to teach them a mnemonic to help remember the units (names, sequences and numerical relationships between them). You can make any sentence you like with words that start with the letters: k, h, d, g, d, c, m. Refer to page 416 in the Addendum for an example suggested by the Department of Basic Education.

Answers

Mass	Groceries
Less than $\frac{1}{4}$ kg	100 g box of tea
$\frac{1}{4}$ kg	250 g packet of sugar
Between $\frac{1}{4}$ kg and $\frac{1}{2}$ kg	410 g tin of beans; 400 g box of cornflakes
$\frac{1}{2}$ kg	500 g packet of flour
Between $\frac{1}{2}$ kg and 1 kg	750 g tin of coffee
1 kg	1 kg cylinder of salt
Between 1 kg and 2 kg	None of the items
More than 2 kg	2,5 kg packet of sugar

1. (a) 2 kg (b) $\frac{1}{2}$ kg (c) $\frac{1}{4}$ kg (d) $1\frac{1}{2}$ kg (e) $2\frac{1}{4}$ kg (f) $\frac{1}{10}$ kg
 4. (a) 2 kg and 650 g (b) 3 kg and 840 g (c) 7 kg and 25 g

2. (a) 3 000 g
 (b) 7 000 g
 (c) 10 000 g
 (d) 500 g
 (e) 250 g
 (f) 100 g
 (g) 2 500 g
 (h) 3 750 g
 (i) 300 g

2.4 Counting in grams and kilograms, and reading scales

Answers

1. (a) 3 kg and 500 g + 250 g → 3 kg and 750 g + 250 g →
 4 kg and 0 g + 250 g → 4 kg and 250 g + 250 g →
 4 kg and 500 g + 250 g → 4 kg and 750 g
 (b) 1 kg and 800 g + 200 g → 2 kg and 0 g + 200 g →
 2 kg and 200 g + 200 g → 2 kg and 400 g + 200 g →
 2 kg and 600 g + 200 g → 2 kg and 800 g

Mass	Grocery items
Less than $\frac{1}{4}$ kg	
$\frac{1}{4}$ kg	
Between $\frac{1}{4}$ kg and $\frac{1}{2}$ kg	
$\frac{1}{2}$ kg	
Between $\frac{1}{2}$ kg and 1 kg	
1 kg	
Between 1 kg and 2 kg	
More than 2 kg	

2. Rewrite the following as grams.
 (a) 3 kg (b) 7 kg (c) 10 kg
 (d) $\frac{1}{2}$ kg (e) $\frac{1}{4}$ kg (f) $\frac{1}{10}$ kg
 (g) $2\frac{1}{2}$ kg (h) $3\frac{3}{4}$ kg (i) $\frac{3}{10}$ kg
3. Rewrite the following as kilograms or fractions of kilograms.
 (a) 2 000 g (b) 500 g (c) 250 g
 (d) 1 500 g (e) 2 250 g (f) 100 g
4. Rewrite the following as kilograms and grams.
 (a) 2 650 g (b) 3 840 g (c) 7 025 g

2.4 Counting in grams and kilograms, and reading scales

1. Count in kilograms and grams.
 (a) 3 kg and 500 g + 250 g → 3 kg and ___ g + 250 g →
 ___ kg and ___ g + 250 g → ___ kg and ___ g + 250 g →
 ___ kg and ___ g + 250 g → ___ kg and ___ g
 (b) 1 kg and 800 g + 200 g → ___ kg and ___ g + 200 g →
 ___ kg and ___ g + 200 g → ___ kg and ___ g + 200 g →
 ___ kg and ___ g + 200 g → ___ kg and ___ g

Teaching guidelines

Learners often assume that there are 10 unnumbered intervals between numbered intervals on all scales. However, some kitchen scales have five unnumbered intervals between each numbered interval (see question 3(f)). Other kitchen scales have four unnumbered intervals between each numbered interval (see question 3(g)).

Learners can use the following steps to find out the mass at the dial/needle/pointer.

- Find the value of the interval between numbered lines.
Subtract the number just before the pointer from the number just after the pointer. In question 3(g) it is $3 - 2 = 1$, so the value between numbered intervals is 1 kg.
- To find the value of the unnumbered intervals, count the number of unnumbered intervals (the *spaces*, not the lines) between numbered intervals. In question 3(g) it is 4.
Divide this number into the value of the numbered intervals. In question 3(g) it is $1\ 000\text{ g} \div 4 = 250\text{ g}$.
- Count on from the numbered interval before the pointer (e.g. in question 3(g) you will count: 2 kg and 250 g, 2 kg and 500 g, 2 kg and 750 g) or count back from the numbered interval after the pointer (e.g. in question 3(f) you will count: 3 kg, 2 kg and 800 g, 2 kg and 600 g).

Answers

2.

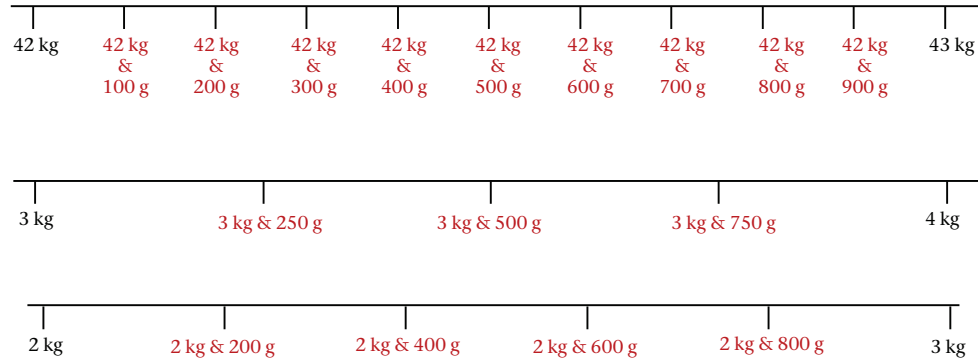

3. (a) 24 kg and 500 g (b) 64 kg and 500 g
 (c) 119 kg and 500 g (d) 100 g
 (e) 120 g (f) 3 kg and 400 g
 (g) 2 kg and 750 g

2. Copy the number lines below. Count the number of spaces between each kilogram. Calculate the value of each space in grams. Fill in the kilograms and grams at each mark on your number lines.

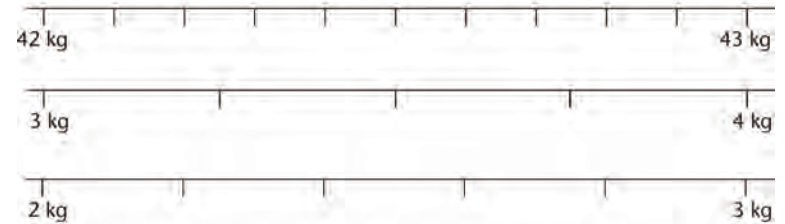

3. Write the mass on each scale in kilograms and grams.

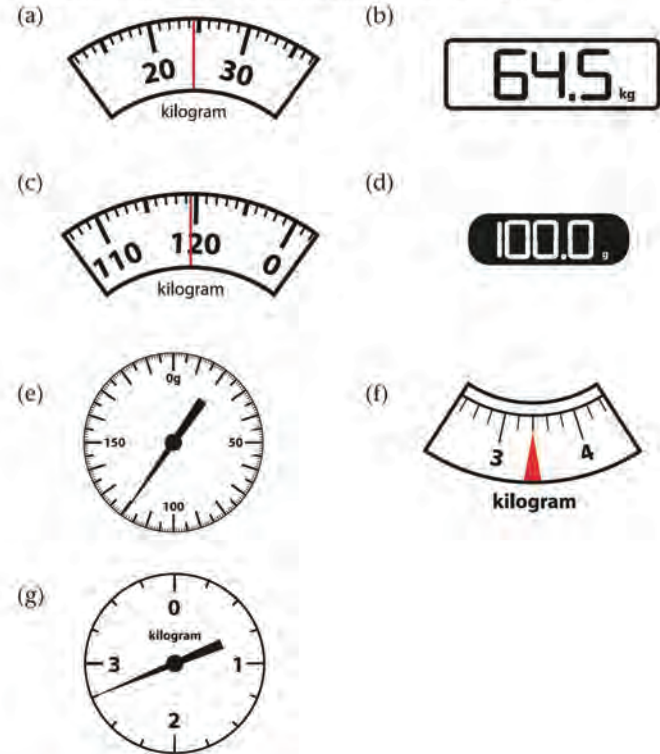

2.5 Solving problems about mass and quantity

Teaching guidelines

Suggest to learners that they quickly make a rough sketch of the situation described in question 1. They should not spend more than 5 minutes on making the sketch, since the purpose is only to help them understand the situation, not to produce a work of art!

Answers

- $200 \text{ g} \times 80 = 16\,000 \text{ g} = 16 \text{ kg}$ This is the mass of the oranges in one box.
 - $16 \text{ kg} \times 60 = 960 \text{ kg}$ This is the mass of 60 boxes of oranges.
 - $960 \text{ kg} \times 12 = 11\,520 \text{ kg}$ This is the mass of 12 crates with 60 boxes of oranges in each crate.
 - $11\,520 \text{ kg} \times 30 = 345\,600 \text{ kg}$ This is the mass of oranges in 30 containers.
- 50 g (mass of half of 60 nails)
 - 25 g (mass of half of 30 nails)
 - 5 g (mass of $\frac{1}{10}$ of 30 nails)
 - 500 g (mass of 5×60 nails)
 - 300 nails
 - 1 200 nails (1 kg has 600 nails, so $2 \times 1 \text{ kg} = 1\,200$ nails)
 - Examples:
 $3 \times 500 \text{ g bag (900 nails)} + 2 \times 100 \text{ g bag (120 nails)} = 1\,020 \text{ nails}$
 $1 \times 1 \text{ kg bag (600 nails)} + 1 \times 500 \text{ g bag (300 nails)} + 2 \times 100 \text{ g bag (120 nails)}$
 $= 1\,020 \text{ nails}$
 $9 \times 100 \text{ g bags (120 nails)} = 1\,080 \text{ nails}$
- $1\frac{1}{2} \text{ kg} = 1\,500 \text{ g}$ $1\,500 \div 200 = 7\frac{1}{2}$ cups of sugar
 - $3 \text{ kg} = 3\,000 \text{ g}$ $3\,000 \div 125 = 24$ cups of flour
 - $1 \text{ kg} = 1\,000 \text{ g}$ $1\,000 \div 225 = \text{just less than } 4\frac{1}{2}$ cups of butter
 - $60 \text{ g} \div 300 = \frac{1}{5}$ cup salt
- $5\,000 \text{ g} \div 20 = 250 \text{ g}$
 - $250 \text{ g} \times 12 = 3\,000 \text{ g}$ or 3 kg

2.5 Solving problems about mass and quantity

- A citrus farm exports oranges to America. They pack about 80 oranges in a box. Then they pack 60 boxes in a crate. Then they pack 12 crates in a shipping container. A single orange has a mass of about 200 g. Work out the following and give each answer in kilograms:

 - the mass of a box of oranges
 - the mass of a crate of oranges
 - the mass of the oranges in one shipping container
 - the total mass of the oranges they export if they export 30 containers in a season
- A hardware store sells bags of nails that weigh 100 g, 500 g and 1 kg. There are about 60 nails in a 100 g bag. Estimate the following:

 - the mass of 30 nails
 - the mass of 15 nails
 - the mass of 3 nails
 - the mass of 300 nails
 - the number of nails in a 500 g bag
 - the number of nails in two 1 kg bags
 - which bags to buy if you need about 1 000 nails
- The table shows the mass of a cupful of different ingredients.

Ingredient (1 cupful or 250 ml)	water	sugar	flour	salt	butter
Mass in grams	250	200	125	300	225

The baker's scale is broken and he will have to use a cup to measure. How many cupfuls are each of these?

- $1\frac{1}{2} \text{ kg}$ of sugar
 - 3 kg of flour
 - 1 kg of butter
 - 60 g of salt
- A turkey has a mass of about 5 kg. The mass of the food it eats per day is about one twentieth of its own mass.

A group of turkeys is called a rafter of turkeys.

 - What is the mass of a turkey's daily food?
 - What mass of food will a rafter of 12 turkeys eat per day?

Learner Book Overview		
Sections in this unit	Content	Pages in Learner Book
3.1 Compare and order numbers	Thinking of large numbers	218 to 220
3.2 Represent and compare numbers	Representing numbers with number names and place value expansions	221 to 222
3.3 An investigation	Large numbers in a practical context	222

CAPS time allocation	1 hour
CAPS page references	13 to 15 and 181

Mathematical background

The following critical aspects of number concept for whole numbers up to one million are addressed in this short unit:

- developing a sense of large quantities, specifically of large collections of objects
- arranging numbers in ascending and descending order
- the composition of numbers with place value parts.

3.1 Compare and order numbers

Teaching guidelines

Questions 2 and 3 were designed to help learners to engage with large quantities in their minds, with a view to empower them to make sense of larger numbers. Doing questions 2 and 3 purely by making rough guesses will already serve the purpose of making learners think of large quantities of objects.

When learners engage with question 2(b) you may suggest to them that they first estimate how many red squares are about equal to a yellow square (ten), and then use their estimate for the number of yellow squares to form an estimate for the number of red squares that will cover the back of the book.

(If time is available now, or when you revisit these questions in another period when time is available, it can be valuable to challenge learners to make good estimates of the answers to questions 2 and 3 by taking rough measurements and doing some calculations.)



Once learners have produced their answer for question 3, you may ask them to estimate how many yellow stickers and how many red stickers will be needed to cover your classroom floor. When reflecting on this sensibly, learners may imagine numbers of the order of half a million and several millions.

Answers

- (a) 309 778
(b) 209 778 278 545 288 103 309 778 312 215
- (a) 500
(b) 5 000
- The number of tiles could be between 1 000 and 100 000.
(The grey square is 5 cm by 5 cm in the Learner Book; hence 400 grey squares cover 1 square metre. A typical classroom is about 10 m by 10 m.)

UNIT3WHOLE NUMBERS

3.1 Compare and order numbers

- (a) Which of the following numbers is closest to three hundred thousand?
278 545 312 215 209 778 309 778 288 103
(b) Arrange the above numbers from smallest to biggest.
- Imagine that the back cover of this textbook is covered with yellow stickers like the one shown here  or with red stickers like the one shown here. 
Imagine that the stickers are pasted neatly next to each other.
(a) Which of the following numbers do you think is closest to the number of yellow stickers needed to cover the back cover?
100 500 1 000 5 000
10 000 50 000 100 000 500 000
(b) Which of the above numbers do you think is closest to the number of red stickers needed to cover the back cover?
- Imagine that your classroom floor is covered with tiles of this size. 
Will the number of tiles be
 - between 100 and 1 000 or
 - between 1 000 and 100 000 or
 - between 100 000 and 999 999?

218UNIT 3: WHOLE NUMBERS

Answers

4. 120 000 126 000 132 000 138 000
 144 000 150 000 156 000 162 000
 168 000 174 000 180 000
5. 321 965 339 365 347 677 366 152
 395 923 398 899 398 987
6. 493 586 465 153 431 999 431 001
 427 180 420 122 420 121
7. Numbers Rounded off to the nearest:
- | | (a) five | (b) ten | (c) hundred | (d) thousand |
|---------|----------|---------|-------------|--------------|
| 427 180 | 427 180 | 427 180 | 427 200 | 427 000 |
| 493 586 | 493 585 | 493 590 | 493 600 | 494 000 |
| 465 153 | 465 155 | 465 150 | 465 200 | 465 000 |
| 420 122 | 420 120 | 420 120 | 420 100 | 420 000 |
| 420 121 | 420 120 | 420 120 | 420 100 | 420 000 |
| 431 999 | 432 000 | 432 000 | 432 000 | 432 000 |
| 431 001 | 431 000 | 431 000 | 431 000 | 431 000 |
8. (a) one hundred; 100
 (b) one million; 1 000 000
 (c) ten thousand; 10 000
 (d) one hundred thousand; 100 000
 (e) one thousand; 1 000

4. Count in six thousands from 120 000 until you reach 180 000. Write down the number symbols as you go along.
5. Arrange the following seven numbers in ascending order (from smallest to biggest).
- 366 152 398 987 395 923 398 899
 321 965 347 677 339 365
6. Arrange the following seven numbers in descending order (from biggest to smallest).
- 427 180 493 586 465 153 420 122
 420 121 431 999 431 001
7. Round each of the numbers in question 6 off to the nearest:
- (a) five
 (b) ten
 (c) hundred
 (d) thousand.
8. Which number should be written at the question mark in each of the number lines? Write the number name and number symbol.

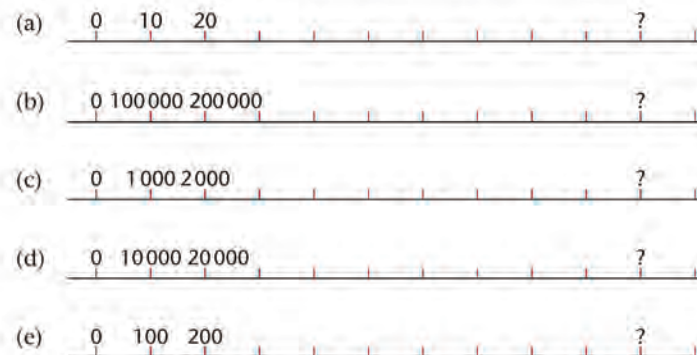

Answers

9. (a) 90 000; 100 000; 110 000; 120 000; 130 000; 140 000; 150 000; 160 000; 170 000
 (b) 440 000; 450 000; 460 000; 470 000; 480 000; 490 000; 500 000; 510 000; 520 000
 (c) 430 000; 480 000; 530 000; 580 000; 630 000; 680 000; 730 000; 780 000; 830 000; 880 000
10. 120 000; 121 500; 123 000; 124 500; 126 000; 127 500; 129 000; 130 500; 132 000
11. (a) 4 000 (b) 7 000 (c) 10 000 (d) 13 000
 (e) 16 000 (f) 19 000 (g) 22 000
12. (a) $160\,054 > 123\,654$ $123\,654 < 160\,054$
 (b) $987\,121 > 789\,121$ $789\,121 < 987\,121$
 (c) $404\,872 < 440\,782$ $440\,782 > 404\,872$
 (d) $144\,544 < 414\,454$ $414\,454 > 144\,544$

9. Which numbers should be written at the question marks in each of the number lines? Write the numbers from smallest to biggest.



10. Count in 1 500s from 120 000 until you reach 132 000. Write down the number symbols as you go along.

11. Write the numbers that should be in the blocks in the diagram.

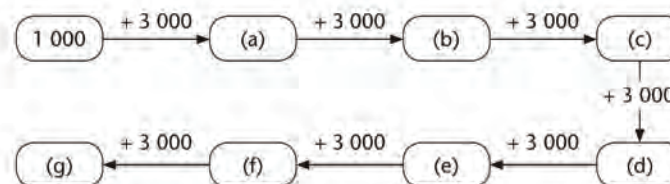

12. In each case decide which is the bigger of the two numbers. Show what you have decided in *two* ways, using the $<$ sign for “smaller than” *and* using the $>$ sign for “bigger than”. Look at the example.

Example: 243 708 and 452 001

$$243\,708 < 452\,001 \text{ and } 452\,001 > 243\,708$$

- (a) 160 054 and 123 654 (b) 987 121 and 789 121
 (c) 404 872 and 440 782 (d) 144 544 and 414 454

3.2 Represent and compare numbers

Answers

1.	Number symbol	Number name	Expanded notation
	423 772	four hundred and twenty-three thousand seven hundred and seventy-two	$400\ 000 + 20\ 000 + 3\ 000 + 700 + 70 + 2$
	611 954	six hundred and eleven thousand nine hundred and fifty-four	$600\ 000 + 10\ 000 + 1\ 000 + 900 + 50 + 4$
	545 756	five hundred and forty-five thousand seven hundred and fifty-six	$500\ 000 + 40\ 000 + 5\ 000 + 700 + 50 + 6$
	701 205	seven hundred and one thousand two hundred and five	$700\ 000 + 1\ 000 + 200 + 5$
	801 630	eight hundred and one thousand six hundred and thirty	$800\ 000 + 1\ 000 + 600 + 30$
	306 301	three hundred and six thousand three hundred and one	$300\ 000 + 6\ 000 + 300 + 1$
	200 036	two hundred thousand and thirty-six	$200\ 000 + 30 + 6$
	870 102	eight hundred and seventy thousand one hundred and two	$800\ 000 + 70\ 000 + 100 + 2$
	909 009	nine hundred and nine thousand and nine	$900\ 000 + 9\ 000 + 9$
	859 560	eight hundred and fifty-nine thousand five hundred and sixty	$800\ 000 + 50\ 000 + 9\ 000 + 500 + 60$
	102 040	one hundred and two thousand and forty	$100\ 000 + 2\ 000 + 40$
	110 300	one hundred and ten thousand three hundred	$100\ 000 + 10\ 000 + 300$
	606 109	six hundred and six thousand one hundred and nine	$600\ 000 + 6\ 000 + 100 + 9$
	800 001	eight hundred thousand and one	$800\ 000 + 1$
	200 909	two hundred thousand nine hundred and nine	$200\ 000 + 900 + 9$

3.2 Represent and compare numbers

1. Copy the table and complete it.

Number symbol	Number name	Expanded notation
	four hundred and twenty-three thousand seven hundred and seventy-two	
611 954		
		$500\ 000 + 40\ 000 + 5\ 000 + 700 + 50 + 6$
	seven hundred and one thousand two hundred and five	
801 630		
		$300\ 000 + 6\ 000 + 300 + 1$
	two hundred thousand and thirty-six	
870 102		
		$900\ 000 + 9\ 000 + 9$
	eight hundred and fifty-nine thousand five hundred and sixty	
102 040		
		$100\ 000 + 10\ 000 + 300$
	six hundred and six thousand one hundred and nine	
800 001		
		$200\ 000 + 900 + 9$

Answers

2. (a) 909 009
(b) 102 040
3. 120 000; 160 000; 200 000; 240 000; 280 000; 320 000; 360 000; 400 000;
440 000; 480 000; 520 000
4. (a) 99 000 (b) 108 000
(c) 117 000 (d) 126 000
(e) 135 000 (f) 144 000
(g) 153 000 (h) 162 000
(i) 171 000 (j) 180 000
(k) 189 000
5. (a) $16\ 654 < 16\ 654$ (b) $16\ 654 > 16\ 154$
(c) $23\ 121 < 23\ 322$ (d) $23\ 322 > 23\ 121$
(e) $44\ 872 > 44\ 782$ (f) $44\ 782 < 44\ 872$
(g) $14\ 544 < 41\ 454$ (h) $41\ 454 > 14\ 544$

3.3 An investigation

Teaching guidelines

Learners will have to do this **project** over a number of days in their own time. Ask them for brief feedback about their progress from time to time.

Answer

Learners' approximations will differ; they need to show how they reasoned and show how they got to the number. An estimate between 6 000 and 14 000 bricks will be reasonable.

2. (a) What is the biggest number in the table in question 1? Write it down.
(b) What is the smallest number? Write it down.

3. Count in 40 000s from 120 000 until you pass 500 000. Write down the number symbols as you go along.

4. Write the numbers that should be in the blocks in the diagram.

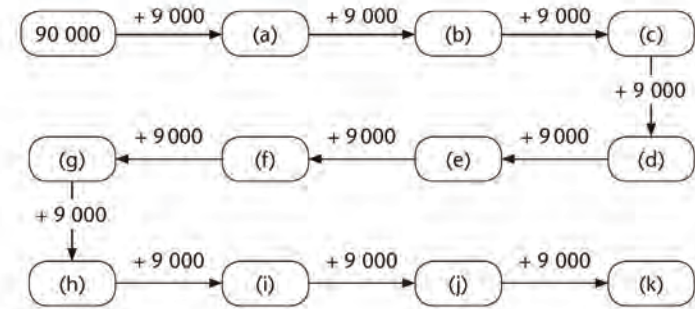

5. In each case decide which is the bigger of the two numbers. Each time show this in two ways, using the < sign for "smaller than" and the > sign for "bigger than".

Example: $13\ 678 < 13\ 768$ and $13\ 768 > 13\ 687$

- (a) 16 154 and 16 654 (b) 23 121 and 23 322
(c) 44 872 and 44 782 (d) 14 544 and 41 454

3.3 An investigation

Approximately how many bricks are needed to build a house with two bedrooms, a bathroom, a kitchen and a lounge/dining room? Give good reasons for your approximation.

An **approximation** is a rough estimate and therefore not exact.

Learner Book Overview		
Sections in this unit	Content	Pages in Learner Book
4.1 Revision, and adding in columns	Introduction of the column format for recording addition	223 to 225
4.2 Subtracting in columns	Introduction of the column format for recording subtraction	226 to 227
4.3 Less writing when adding in columns	Refinement of the column format for recording addition	228 to 230
4.4 Another way of subtracting in columns	Subtraction in columns with transfer between place value positions	231 to 232
4.5 Solve problems	Word problems involving addition and subtraction	232

CAPS time allocation	5 hours
CAPS page references	13 to 15 and 182 to 183

Mathematical background

Doing addition in columns and doing subtraction in columns are not new methods or methods different to the breaking down and building up methods that learners have used previously. Working in columns is simply an *alternative format* for setting out the work, and it has the advantage that it can be abbreviated by not recording all the thinking steps.

The transition from addition and subtraction by breaking down and building up, as learners have done it up to now, to the so-called “column methods” is not a change of method; it is a change of formatting style and a reduction in the extent to which the actual mathematical steps or thinking is recorded in writing.

The activities in this unit provide learners with opportunities to make a gradual transition from the detailed documentation of thinking steps that they did in Terms 1 and 2, to the more economical column format of setting out addition and subtraction.

4.1 Revision, and adding in columns

Teaching guidelines

Inform learners that they will learn a different way of setting out their thinking for addition and subtraction.

Possible misconceptions

The misconception that working in columns is a different method to breaking down the numbers into place value parts, and rearranging and calculating the parts separately before adding the answers up, should be resisted. Working in columns is just one of the various ways in which the method can be set out in writing. Several important thinking steps, such as breaking the numbers down into place value parts, are not written down in the traditional column format.

Answers

- (a) $8\ 000 + 200 + 50 + 4 + 3\ 000 + 400 + 30 + 2 = 11\ 686$
(b) $5\ 000 + 600 + 80 + 7 + 2\ 000 + 700 + 30 + 6 = 8\ 423$
- The mistakes in Steve's work are highlighted in red:

$$\begin{aligned}5\ 687 &= 5\ 000 + 400 + 80 + 7 \\2\ 736 &= 2\ 000 + 700 + 30 + 6 \\5\ 687 + 2\ 736 &= 8\ 000 + 1\ 100 + 110 + 13 \\&= 9\ 000 + 200 + 10 + 3 \\&= 9\ 213\end{aligned}$$

The following example of a note explains what Steve did wrong. These mistakes should be mentioned in learners' notes. Learners' wording may of course differ.

Steve, you broke down the 5 687 incorrectly: the 400 should be 600.

You added the thousands incorrectly: $5\ 000 + 2\ 000 = 7\ 000$ and not $8\ 000$. You also forgot to add one ten, probably the ten in 110.

The correct answer is 8 423 (as in question 1(b)).

- Learners use the method shown in the tinted passage.
(a) 1 337 (b) 1 301 (c) 12 394 (d) 82 621

UNIT

4

WHOLE NUMBERS:

ADDITION AND SUBTRACTION

In this unit you will learn how to write less when you add and subtract. This will make it easier for you to write up your work when you work with large numbers. To start, you need to make sure that you understand how to do addition and subtraction, and get some practice.

4.1 Revision, and adding in columns

- Calculate by first breaking down the numbers into place value parts. Show what you are thinking while you are doing each calculation.
(a) $8\ 254 + 3\ 432$ (b) $5\ 687 + 2\ 736$

You can write like this to show what you are thinking when you calculate $765 + 857$:

$$\begin{aligned}765 &= 700 + 60 + 5 && \text{Step 1: Break down the numbers} \\857 &= 800 + 50 + 7 && \text{into place value parts.} \\765 + 857 &= 1\ 500 + 110 + 12 && \text{Step 2: Add corresponding parts.} \\&= 1\ 600 + 20 + 2 && \text{Step 3: Make transfers to obtain the} \\& && \text{place value parts of the answer.} \\&= 1\ 622 && \text{Step 4: Build up the answer.}\end{aligned}$$

- Steve did the work below. Find the mistakes in Steve's work. Write a short note to Steve, in which you tell him what he did wrong.

$$\begin{aligned}5\ 687 &= 5\ 000 + 400 + 80 + 7 \\2\ 736 &= 2\ 000 + 700 + 30 + 6 \\5\ 687 + 2\ 736 &= 8\ 000 + 1\ 100 + 110 + 13 \\&= 9\ 000 + 200 + 10 + 3 \\&= 9\ 213\end{aligned}$$

- Calculate and write your work as shown in the example above question 2.
(a) $859 + 478$ (b) $537 + 764$
(c) $4\ 736 + 7\ 658$ (d) $48\ 673 + 33\ 948$

Possible misconceptions

Care must be taken to prevent learners from forming the misconception that “adding in columns” as demonstrated in the second tinted passage is a different method of addition to the method demonstrated in the tinted passage at the top of the page. Both passages show addition by breaking down into place value parts and building up the answers. There is no mathematical difference, no difference in the way of thinking between the two passages.

Teaching guidelines

At this stage learners are used to documenting addition as shown in the tinted passage at the top of the page. Tell them that they will now learn a shorter way to set out the work. In the shorter way, some of the things that happen in your mind when you do addition are not written down. This can be shown clearly by writing the work in the tinted passage (or similar work with different numbers) on the board, and then deleting the parts that are not written down in column notation.

$$\begin{aligned} 6\ 524 &= 6\ 000 + 500 + 20 + 4 \\ 3\ 245 &= 3\ 000 + 200 + 40 + 5 \\ 6\ 524 + 3\ 245 &= 9\ 000 + 700 + 60 + 9 \\ &= 9\ 769 \end{aligned}$$

Write on the board:

(You may write the parts that will be deleted with a different coloured chalk.)

Now delete the grey parts:

$$\begin{aligned} \del{6}\ 524 &= \del{6}\ 000 + 500 + 20 + 4 \\ \del{3}\ 245 &= \del{3}\ 000 + 200 + 40 + 5 \\ \del{6}\ 524 + \del{3}\ 245 &= \del{9}\ 000 + 700 + 60 + 9 \\ &= 9\ 769 \end{aligned}$$

Then do another addition on the board, for example with the numbers in the second tinted passage, without writing the expansions and the reasons for the part answers. However, state the expansions and reasons for the part answers verbally.

Answers

4. Learners should set out their work as shown in the first tinted passage.

(a) 10 967 (b) 77 887

5. (a) $\begin{array}{r} 5\ 436 \\ + 3\ 352 \\ \hline 8\ 788 \end{array}$ (b) $\begin{array}{r} 23\ 572 \\ + 53\ 215 \\ \hline 76\ 787 \end{array}$ (c) $\begin{array}{r} 35\ 254 \\ + 42\ 623 \\ \hline 77\ 877 \end{array}$ (d) $\begin{array}{r} 23\ 234 \\ 32\ 123 \\ + 11\ 442 \\ \hline 66\ 799 \end{array}$

In a case such as $6\ 524 + 3\ 245$ you do not need to make any transfers, so you need only three steps.

$$\begin{aligned} 6\ 524 &= 6\ 000 + 500 + 20 + 4 && \text{Step 1: Break down.} \\ 3\ 245 &= 3\ 000 + 200 + 40 + 5 \\ 6\ 524 + 3\ 245 &= 9\ 000 + 700 + 60 + 9 && \text{Step 2: Add the parts.} \\ &= 9\ 769 && \text{Step 3: Build up.} \end{aligned}$$

When you want to explain to someone else how you thought, it is good to write down the separate place value parts in Step 2. But if you are just interested in getting to the answer, you can combine the place value parts in your mind and write the answer directly as shown below.

$$\begin{aligned} 6\ 524 &= 6\ 000 + 500 + 20 + 4 \\ 3\ 245 &= 3\ 000 + 200 + 40 + 5 \\ 6\ 524 + 3\ 245 &= 9\ 769 \end{aligned}$$

4. Do these calculations by writing as in the example printed in colour above.

(a) $7\ 435 + 3\ 532$ (b) $43\ 364 + 34\ 523$

When you are not explaining but just trying to find the answer, you can write even less if no transfers are needed.

Look at this example for the calculation of $4\ 345 + 3\ 253$:

$$\begin{array}{r} 4\ 345 \\ + 3\ 253 \\ \hline 7\ 598 \end{array}$$

Think of 4 345 as 4 000 + 300 + 40 + 5 but do not write it.
Think of 3 253 as 3 000 + 200 + 50 + 3 but do not write it.
Think of 5 + 3 = 8, 40 + 50 = 90, 300 + 200 = 500 and 4 000 + 3 000 = 7 000 and 7 000 + 500 + 90 + 8, but only write 7 598.

When you write like this to do addition, we say you **add in columns**.

5. Think and write like in the above example to calculate the following:

(a) $5\ 436 + 3\ 352$ (b) $23\ 572 + 53\ 215$
(c) $35\ 254 + 42\ 623$ (d) $23\ 234 + 32\ 123 + 11\ 442$

Possible misconceptions

The introduction of column addition is done gradually in order to protect learners against losing sight of place value when adding in columns, for example acting on the misconception that single-digit numbers are added in each column. Also see “Possible misconceptions” on page 132 of this Teacher Guide.

Teaching guidelines

For cases that require transfers between columns to produce the final answer, an extended form of adding in columns is introduced in the tinted passage. (The traditional condensed form of column exposition, in which the answer is produced in one line, is only introduced at the end of Section 4.3, i.e. on page 230 of the Learner Book.)

The tinted passage can be used as the basis for a lesson and demonstration.

Answers

6. Learners add in columns to get to the answer 1 337.

<p>7. (a)</p> $\begin{array}{r} 26\ 987 \\ + 54\ 654 \\ \hline 11 \quad \dots (7 + 4) \\ 130 \quad \dots (80 + 50) \\ 1\ 500 \quad \dots (900 + 600) \\ 10\ 000 \quad \dots (6\ 000 + 4\ 000) \\ \hline 70\ 000 \quad \dots (20\ 000 + 50\ 000) \\ \hline 81\ 641 \end{array}$	<p>(b)</p> $\begin{array}{r} 44\ 887 \\ + 47\ 596 \\ \hline 13 \quad \dots (7 + 6) \\ 170 \quad \dots (80 + 90) \\ 1\ 300 \quad \dots (800 + 500) \\ 11\ 000 \quad \dots (4\ 000 + 7\ 000) \\ \hline 80\ 000 \quad \dots (40\ 000 + 40\ 000) \\ \hline 92\ 483 \end{array}$
--	---

8. Below is an example of a note. Learners explain in their own words.

Thuli, you did not write the ten and hundred parts correctly. You should have written $70 + 90 = 160$ and $600 + 800 = 1\ 400$.

When you added up, you did not keep the place values in mind correctly. The correct answer is $1\ 400 + 160 + 11 = 1\ 571$.

9. Learners add in columns.

(a) 82 534	(b) 60 123	(c) 64 644	
(d) 98 887	(e) 6 608	(f) 39 066	

6. Try to calculate $859 + 478$ by adding in columns. You may find that it does not work.

When you try to calculate $3\ 658 + 5\ 736$ by writing in columns, you will experience a problem.

You can calculate $8 + 6 = 14$ and write the 14.

If you now calculate $50 + 30 = 80$, you will find that the “1” of the 14 sits in the place where you want to write the “8” of the 80.

$$\begin{array}{r} 3\ 658 \\ + 5\ 736 \\ \hline 14 \\ ???\nearrow \\ 80 \end{array}$$

Fortunately there is a simple solution for this problem. You can write the 80 in the next line, and continue to write the total for each kind of place value part in a new line, as shown in red below.

It is now easy to form the answer from the **part answers** for the different kinds of place value parts.

The **reasons for the part answers** are shown in blue.

3 658	
+ 5 736	
14	... (8 + 6)
80	... (50 + 30)
1 300	... (600 + 700)
8 000	... (3 000 + 5 000)
9 394	

7. Calculate each of the following. Record your thinking in columns as shown above. Write the reasons for the part answers.

(a) $26\ 987 + 54\ 654$ (b) $44\ 887 + 47\ 596$

8. Thuli calculated $676 + 895$ as shown here. She made mistakes. Find the mistakes. Write a short note to Thuli, in which you tell her what she did wrong.

$$\begin{array}{r} 676 \\ + 895 \\ \hline 11 \quad \dots (6 + 5) \\ 16 \quad \dots (7 + 9) \\ \hline 140 \quad \dots (6 + 8) \\ \hline 1\ 670 \end{array}$$

9. Calculate the following by writing in columns. You do not have to show the reasons for the part answers.

(a) $36\ 876 + 45\ 658$	(b) $23\ 568 + 8\ 679 + 27\ 876$
(c) $25\ 886 + 38\ 758$	(d) $44\ 362 + 54\ 525$
(e) $578 + 649 + 735 + 847 + 547 + 2\ 376 + 876$	
(f) $8\ 564 + 12\ 568 + 4\ 658 + 13\ 276$	

4.2 Subtracting in columns

Teaching guidelines

You can develop the two representations of calculating $876 - 254$ simultaneously side by side on the board, writing the descriptions of the various steps in the middle. The format that learners used previously (in Term 2) is on the left. The first two lines are exactly the same:

<u>The “old” way of writing</u>		<u>A new way of writing</u>
$876 = 800 + 70 + 6$	Break both numbers down	$876 = 800 + 70 + 6$
$254 = 200 + 50 + 4$	into their place value parts.	$254 = 200 + 50 + 4$
$876 - 254 = 600 + 20 + 2$	Subtract corresponding parts.	

Once the above is on the board, you may explain that the last step can be written down in a different way, and demonstrate it on the right as shown in red below:

$876 = 800 + 70 + 6$	Break both numbers down	$876 = 800 + 70 + 6$
$254 = 200 + 50 + 4$	into their place value parts.	$254 = 200 + 50 + 4$
$876 - 254 = 600 + 20 + 2$	Subtract corresponding parts.	2
		20
		600

To encourage learners to apply their minds to your presentation, you may at this stage ask them to copy what you have written into their books, and to complete the calculations in both the “old” and new ways of writing.

Note that question 3 requires learners to use the new “vertical” format, but to write the place value expansions of the numbers down. In question 4, on page 227 of the Learner Book, learners are invited to try to do the calculations by just keeping the place value expansions in their mind, and not writing them down.

Answers

- (a) 622 (b) 3 314 (c) 4 378 (d) 55 134
- Learners describe what they did in question 1(b) and (d) by following the instructions.
- Learners follow the instructed method to find the answers:
 - 2 643 (b) 25 260

4.2 Subtracting in columns

- Calculate:
 - $876 - 254$
 - $7\,967 - 4\,653$
 - $8\,254 - 3\,876$
 - $78\,668 - 23\,534$

When you calculate $876 - 254$ by breaking down the numbers into place value parts and building up the answer, you can write this to show how you are thinking:

$$\begin{array}{l}
 876 = 800 + 70 + 6 \\
 254 = 200 + 50 + 4 \\
 876 - 254 = 600 + 20 + 2 \\
 = 622
 \end{array}$$

Step 1: Break down the numbers into place value parts.
Step 2: Subtract corresponding parts.
Step 3: Build up the answer.

This way of writing is sometimes called “the expanded column notation”, because the numbers are written in expanded notation.

You can also record your thinking in the “vertical” way shown below.

$$\begin{array}{r}
 876 = 800 + 70 + 6 \\
 - 254 = 200 + 50 + 4 \\
 \hline
 2 \dots (6 - 4) \\
 20 \dots (70 - 50) \\
 + 600 \dots (800 - 200) \\
 \hline
 622 \dots (2 + 20 + 600)
 \end{array}$$

Step 1: Break down.
Step 2: Subtract corresponding parts.
Step 3: Build up the answer.

The parts in red show the expanded notation of the numbers that are to be subtracted. The parts in black show the parts of the answer. The parts in blue show how the part answers were obtained.

This way of writing subtraction is called **subtracting in columns**.

- Describe what you did in questions 1(b) and (d) by writing in columns as in the above example. Include the expanded notation (red in the example), the part answers (black in the example) and the reasons for the part answers (blue in the example).
- Calculate the following and record your thinking in the vertical way. Write the expanded notation and the explanations for the part answers (the parts in blue in the example).
 - $8\,985 - 6\,342$
 - $48\,684 - 23\,424$

Teaching guidelines

The requirement not to write the place value expansions in Grade 5 should not be rigidly enforced. Learners who need to write expansions in order to have clarity on what calculations to do should be allowed to do so.

Answers

4. Learners are to set out the work as instructed.
(a) 5 412 (b) 9 503 (c) 52 322 (d) 41 524
5. (a) 4 402 (b) 6 353 (c) 35 261 (d) 44 223
6. (a) 40 000 (b) 5 437
7. $63\,352 = 3\,353 + 59\,999$
 $63\,352 - 27\,685 = 59\,999 - 27\,685 + 3\,353$
 $= 32\,314 + 3\,353$
 $= 35\,667$
8. Learners do the calculations by writing in columns.
(a) 5 664 (b) 26 556 (c) 42 315 (d) 42 550
9. 38 965 other kinds of vehicles

4. Calculate each of the following. Record your thinking by writing in columns (the vertical way). Write the reasons for the part answers, but do not write the numbers in expanded notation.
(a) $8\,856 - 3\,444$ (b) $18\,768 - 9\,265$
(c) $76\,496 - 24\,174$ (d) $78\,768 - 37\,244$

In a case such as $8\,985 - 6\,342$, you can build the answer up directly and write it while you do the calculations $8\,985$
 $- 6\,342$
 $5 - 2, 80 - 40, 900 - 300$ and $8\,000 - 6\,000$ in your mind. $2\,643$

5. Calculate each of the following. Write as little as possible.
(a) $6\,756 - 2\,354$ (b) $12\,785 - 6\,432$
(c) $56\,896 - 21\,635$ (d) $67\,657 - 23\,434$
6. Find the missing numbers in these number sentences:
(a) $45\,436 = 5\,436 + \dots\dots$
(b) $45\,436 = \dots\dots + 39\,999$
7. Replace $63\,352$ by *some number* + $59\,999$ and then calculate $63\,352 - 27\,685$ by first calculating $59\,999 - 27\,685$.
You do not have to write your work in the vertical way now.

When you calculate $63\,254 - 27\,786$ by replacing $63\,254$ by $3\,255 + 59\,999$, you can write in columns as shown here.

$59\,999$
$- 27\,786$
$\hline 32\,213$
$+ 3\,255$
$\hline 35\,468$

8. Do these calculations by writing in columns.
(a) $9\,542 - 3\,878$ (b) $53\,345 - 26\,789$
(c) $76\,768 - 34\,453$ (d) $68\,374 - 25\,824$
9. 97 373 new vehicles were registered last year in a certain province. Of those, 58 408 were sedans. How many other kinds of vehicles were registered?

4.3 Less writing when adding in columns

Mathematical notes

Traditionally, addition with carrying was set out as shown on the right for $4\,697 + 8\,956$. The blue marks, from right to left, actually indicate 10, 100 and 1 000. When the marks are read as “1”, “1” and “1” and the thinking for the tens column is “ $1 + 9 + 5 = 15$ ”, for the hundreds column “ $1 + 6 + 9 = 16$ ”, and for the thousands column “ $1 + 4 + 8 = 13$ ”, learners’ awareness and understanding of place value and of the actual numbers *four thousand six hundred and ninety-seven* and *eight thousand nine hundred and fifty-six* may be seriously undermined.

$$\begin{array}{r} \\ 4\,697 \\ + 8\,956 \\ \hline 13\,653 \end{array}$$

With a view to maintain learners’ awareness and understanding of place value and of the actual numbers involved, the transition from separate recording of the column totals (part answers) to the traditional condensed form of the column format is introduced gradually through the phases demonstrated below.

$$\begin{array}{r} 4\,697 \\ + 8\,956 \\ \hline 13 \\ 140 \\ 1\,500 \\ \hline 12\,000 \\ 13\,653 \end{array} \longrightarrow \begin{array}{r} 4\,697 \\ + 8\,956 \\ \hline 12\,543 \\ 10 \\ 100 \\ \hline 1\,000 \\ 13\,653 \end{array} \longrightarrow \begin{array}{r} 4\,697 \\ + 8\,956 \\ \hline 13\,653 \\ \cancel{40} \\ \cancel{400} \\ \cancel{4\,000} \end{array} \longrightarrow \begin{array}{r} \\ 4\,697 \\ + 8\,956 \\ \hline 13\,653 \end{array}$$

Page 228 of LB

Form A

Page 228 of LB

Form B

Page 229 of LB

Form C

Page 230 of LB

Form D

Teaching guidelines

You may write Forms A and B above on the left and right sides of the board respectively and explain the various steps as shown in the tinted passage, indicating that Form A and Form B are just two different ways of capturing the same thinking in writing. A more detailed description of how the presentation may proceed is given on page 229.

It is advisable to repeat the above presentation with different numbers, for example for $6\,857 + 4\,685$.

Note that in order to be able to add multi-digit numbers, learners can use Form A, i.e. add the different place value parts individually and then add up the column totals. The value of taking the trouble to learn to use Form D is that it may proceed a bit faster than Form A if performed confidently, and it also saves writing space. *Learners who lose the capacity to use Form A, and use Form D without confidence and understanding, and make mistakes, are worse off than learners who do not progress beyond Form A.*

4.3 Less writing when adding in columns

The calculations for $2\,257 + 3\,432$ and $4\,697 + 8\,956$ are shown on the right.

$$\begin{array}{r} 2\,257 \\ + 3\,432 \\ \hline 5\,689 \end{array}$$

For $2\,257 + 3\,432$ the answer is built up and written without writing the part answers first.

$$\begin{array}{r} 4\,697 \\ + 8\,956 \\ \hline 13 \\ 140 \\ \hline 1\,500 \end{array}$$

For $4\,697 + 8\,956$ the part answers are written down first, and then added up to form the answer.

$$\begin{array}{r} 12\,000 \\ 13\,653 \end{array}$$

It would be nice to write the work for $4\,697 + 8\,956$ in a shorter way. You will now explore some possibilities for doing that.

The part answers for $4\,697 + 8\,956$ can be written down in a different way. When you add 6 to 7 you can write the 13 in two parts as shown on the right.

$$\begin{array}{r} 4\,697 \\ + 8\,956 \\ \hline 3 \\ 10 \\ \hline 10 \end{array}$$

By doing this, the space under the 90 and 50 is left open.

When $50 + 90 = 140$ is calculated in the next step, the 140 can also be written in two parts as shown on the right. This leaves the space to the left of the “4” open for the next step, when $600 + 900$ is calculated.

$$\begin{array}{r} 4\,697 \\ + 8\,956 \\ \hline 3 \\ 40 \\ \hline 100 \end{array}$$

By continuing in this way, the calculation can be written up as shown on the right.

$$\begin{array}{r} 4\,697 \\ + 8\,956 \\ \hline 12\,543 \\ 10 \\ 100 \\ \hline 1\,000 \\ 13\,653 \end{array}$$

Teaching guidelines

Let learners do question 1. Note that the writing format forces them to break down the part answer (column total) for each column before they write something down. They have not done this before, hence they may find it a bit difficult to adapt to this way of working.

Suggest to learners who really struggle that they first do question 1(a) by writing the column totals separately as they did in Section 4.1, then rewrite their work in the form indicated in the example for $4\ 697 + 8\ 956$. You may also repeat the presentation in which Form A (see previous page, writing each column total down separately) is compared to Form B (writing the place value parts of the column totals separately), for $8\ 956 + 7\ 688$, or other numbers.

It serves little purpose to proceed to Form C as described in the tinted passage with learners who are not confident in using Form B. Learners who still lack confidence when they do question 1(c) should be allowed additional practice in using Form B, for example the following:

$$\begin{array}{r} 6\ 489 + 8\ 745 \\ 47\ 586 + 9\ 565 \end{array} \quad \begin{array}{r} 7\ 765 + 8\ 588 \\ 35\ 657 + 47\ 754 \end{array} \quad \begin{array}{r} 4\ 865 + 4\ 567 + 5\ 243 \end{array}$$

Learners who are able to use Form B confidently when they have finished question 1, may be allowed to proceed on their own by reading the tinted passage and engaging with the exercises that follow.

Answers

1. (a)	7 688	(b)	45 847	(c)	38 586	2. (a)	8 867	(b)	45 886	(c)	26 783	(d)	55 378
	<u>+8 567</u>		<u>+37 586</u>		<u>+26 795</u>		<u>+7 968</u>		<u>+38 657</u>		<u>+48 894</u>		<u>+28 257</u>
	15 145		72 323		54 271		16 835		84 543		75 677		83 635
	10		10		10		10		10		100		10
	100		100		100		100		100		1 000		100
			1 000		1 000		1 000		1 000		10 000		10 000
	<u>1 000</u>		<u>10 000</u>		<u>10 000</u>				10 000				
	16 255		83 433		65 381								

3. 7 668

$$\begin{array}{r} +8\ 897 \\ 16\ 565 \end{array}$$

Do not pressurise learners who do not manage this.

1. Do these calculations by writing as shown in the example on the right.

(a)	$7\ 688 + 8\ 567$	$4\ 697$
		<u>+ 8 956</u>
		12 543
		10
(b)	$45\ 847 + 37\ 586$	100
		<u>1 000</u>
		13 653

Instead of adding only the 90 and 50 in the second step of the calculation shown in the above example, you can calculate $90 + 50 + 10 = 150$, and write it as shown on the right.

	$4\ 697$
	<u>+ 8 956</u>
	53
	10
	100

We say you “carry” the 10 from the $7 + 6 = 13$ to the $90 + 50 = 140$, to make it 150. You can also say you **transfer** the 10.

Similarly, you can transfer (carry) the 100 of 150 to $600 + 900$ in the next step.

	$4\ 697$
	<u>+ 8 956</u>
	653
	10
	100
	1 000

You then have $600 + 900 + 100$ and the written work will look like this.

In the next step you carry 1 000.

On the right you can see what you will have written when you have finished.

	$4\ 697$
	<u>+ 8 956</u>
	13 653
	10
	100
	1 000

You will soon try to do addition without actually writing the 10, 100 and 1 000 down.

2. Do these calculations by working in the above way.

(a) $8\ 867 + 7\ 968$ (b) $45\ 886 + 38\ 657$

(c) $26\ 783 + 48\ 894$ (d) $55\ 378 + 28\ 257$

3. Try to calculate $7\ 668 + 8\ 897$ by writing in the above way but without writing the 10, 100 and 1 000.

Teaching guidelines

Once learners have completed question 4, let them calculate $34\ 697 + 48\ 956$, thinking and writing any way they prefer. Let them then look at the tinted passage and identify which of A, B, C and D best describes their own work.

Answers

4. $45\ 886 = 40\ 000 + 5\ 000 + 800 + 80 + 6$
 $38\ 657 = 30\ 000 + 8\ 000 + 600 + 50 + 7$
 $45\ 886 + 38\ 657 = 70\ 000 + 13\ 000 + 1\ 400 + 130 + 13$
 $= 80\ 000 + 4\ 000 + 500 + 40 + 3$
 $= 84\ 543$
5. (a) 94 525 (b) 64 623 (c) 89 047
 (d) 67 894 (e) 85 762 (f) 65 956
6. R47 029
7. 76 343 houses

4. Show how your work for question 2(b) can be written in the way you wrote in Terms 1 and 2 (the “expanded column notation”), before you learnt to write in the vertical way.

Here are four different ways to write the work vertically when you calculate $34\ 697 + 48\ 956$:

A	B	C	D
34 697	34 697	10 000	11 11
+ 48 956	+ 48 956	1 000	34 697
<u>13</u>	<u>83 653</u>	100	+ 48 956
140	10	10	<u>83 653</u>
1 500	100	34 697	
12 000	1 000	+ 48 956	
<u>70 000</u>	<u>10 000</u>	<u>83 653</u>	
83 653			

The symbols “1”, “1”, “1” and “1” at the top of D actually mean 10, 100, 1 000 and 10 000, as shown in C.

You can use any of the above ways of writing, but you should try to get used to making transfers and writing like in B, C or D.

In fact, it would be good if you can learn to make the transfers without any writing to remind you of the 10, 100, 1 000 or 10 000, as shown on the right.

$$\begin{array}{r} 34\ 697 \\ + 48\ 956 \\ \hline 83\ 653 \end{array}$$

5. Calculate.
- (a) $57\ 658 + 36\ 867$ (b) $27\ 858 + 36\ 765$
 (c) $65\ 483 + 23\ 564$ (d) $13\ 537 + 33\ 148 + 21\ 209$
 (e) $27\ 334 + 58\ 428$ (f) $43\ 569 + 22\ 387$
6. Ben earns R14 786 each month, Sally earns R16 787 and Zweli earns R15 456. How much do they earn together?
7. There are 57 866 houses in a large township. How many houses will there be if 18 477 more houses are built?

4.4 Another way of subtracting in columns

Mathematical notes

It is important to realise that learners are not dependent on the breaking down and building up method of subtraction in column format, or any other format, to be able to subtract with multi-digit numbers. Adding on as demonstrated at the top of the tinted passage is a highly effective method of subtraction. It works in the same way for all numbers and does not present technical difficulties like those that require transfer (“borrowing”) in the traditional breaking down and building up method.

Teaching guidelines

Three different methods of subtraction are demonstrated in the tinted passage:

- adding on method
- change-and-compensate method
- transfer method or borrowing method.

Demonstrate the three methods for $63\,543 - 27\,688$ on the board. You may skip the different shorter ways of writing up the transfer method, given at the bottom of the tinted passage.

Let learners then engage with questions 1, 2, 3 and 4 on the next page.

4.4 Another way of subtracting in columns

$63\,543 - 27\,688$ can be calculated by **adding on** to $27\,688$ until you reach $63\,543$:

$$27\,688 + 12 \rightarrow 27\,700 + 2\,300 \rightarrow 30\,000 + 33\,543 = 63\,543$$

12
2 300
+ 33 543
35 855

A different way to calculate $63\,543 - 27\,688$ is to break down both numbers into place value parts as shown below.

$$63\,543 = 60\,000 + 3\,000 + 500 + 40 + 3$$

$$27\,688 = 20\,000 + 7\,000 + 600 + 80 + 8$$

There is not enough to subtract from in the thousands, hundreds, tens and units columns.

One way to get around this difficulty is to replace $63\,543$ by $3\,543 + 60\,000$ and then by $3\,544 + 59\,999$. You can then calculate $59\,999 - 27\,688$ and add $3\,544$. This is called the **change-and-compensate method**. You can write this in columns as shown on the right.

59 999
- 27 688
32 311
+ 3 544
35 855

Another way is to make transfers in the expanded notation of $63\,543$, so that the parts of $27\,688$ can be easily subtracted from it:

$$63\,543 = 60\,000 + 3\,000 + 500 + 40 + 3$$

$$= 50\,000 + 12\,000 + 1\,400 + 130 + 13$$

$$27\,688 = 20\,000 + 7\,000 + 600 + 80 + 8$$

$$63\,543 - 27\,688 = 30\,000 + 5\,000 + 800 + 50 + 5$$

$$= 35\,855$$

This is called the **transfer method** or the **borrowing method**.

Different ways of writing this work in columns are shown on the right.

50 000	50 000	12 000	1 400	130	13
12 000	6	3	5	4	3
1 400	-2	7	6	8	8
130	3	5	8	5	5
13					
63 543		50	12	14	13
- 27 688		6	3	5	4
35 855		-2	7	6	8
63 543		3	5	8	5
- 27 688					
35 855					

Answers

- Learners do the calculations using the borrowing method.
(a) 2 464 (b) 33 646
- Learners check their answers for question 1 using the adding on method.
- Learners do the calculations using the borrowing method.
(a) 44 547 (b) 55 869
- Learners check their answers for question 3 using the change-and-compensate method.

4.5 Solve problems

Teaching guidelines

You may suggest to learners that if they are unclear about what calculation to do, they could first write a **number sentence** to represent the situation. The number sentence may help learners to make a correct **calculation plan**. Number sentences that describe the situations in some of the questions are given below.

Question 1: $\square + 35\,255 = 89\,034$, which indicates the calculation plan $89\,034 - 35\,255$.

Question 2: $35\,794 + \square = 45\,880$, which indicates the calculation plan $45\,880 - 35\,794$.

Question 3: The number sentence is $\square - 10\,550 = 79\,600$. However, in this case learners may have less trouble to identify the calculation plan $79\,600 + 10\,550$ directly, without describing the situation with a number sentence first.

For questions 4 and 5 the appropriate calculation plans $21\,876 + 35\,889$ and $19\,655 - 18\,564$ are easy to identify, and it serves no purpose to write number sentences.

Question 6: If learners do not see immediately that they have to subtract 79 093 from 85 084, it may help them to write the number sentence $79\,093 + \square = 85\,084$.

Answers

- 53 779 hectares
- 10 086 chickens
- 90 150 impalas
- 57 765 m
- R1 091
- 5 991 km

- Do these calculations using the *borrowing method*. Write your work in columns in any of the ways shown in the example.
(a) $8\,342 - 5\,878$ (b) $62\,435 - 28\,789$
- Check your answers for question 1 by doing the same calculations using the *adding on method*.
- Do these calculations using the *borrowing method*. Write your work in columns.
(a) $63\,334 - 18\,787$ (b) $93\,534 - 37\,665$
- Check your answers for question 3 by doing the same calculations using the *change-and-compensate method*.

4.5 Solve problems

- Pipes were laid so that 35 255 more hectares of land could be irrigated. That brought the total of irrigated land to 89 034 hectares. How many hectares were already under irrigation?
- An agreement was reached to import 45 880 frozen chickens. A food chain has already received 35 794 frozen chickens. How many must still be imported?
- There were too many impalas in the national parks, so 10 550 had to be culled. Afterwards, there were 79 600. How many impalas were there in the parks originally?
- Practising for a marathon, a long distance runner tries to put in extra distance over the weekends. Last week Saturday he ran 21 876 m and Sunday he ran 35 889 m. How many metres did he run over the weekend?
- The owner of a small block of flats earned R18 564 each month by renting out the flats. After he increased the rent, he earned R19 655 per month. How much more did he earn?
- The odometer of a car showed 79 093. After a long trip, it read 85 084. How many kilometres did the driver travel?

Learner Book Overview		
Sections in this unit	Content	Pages in Learner Book
5.1 Different views of the same object	Objects look different when viewed from different positions	233
5.2 What you see from different places	More about the way objects look when seen from different positions	234 to 235

CAPS time allocation	3 hours
CAPS page references	23 and 184

Mathematical background

This unit is about taking more careful notice of how the same object can look very different when it is viewed from different positions.

This awareness is important when one aims to develop learners' spatial sense of three-dimensional objects. It is also important when one has to draw a three-dimensional object, especially if the object is not a simple one. One will then draw such an object as seen from a number of different positions. Together the drawings become a useful tool to understand the total spatial form of the object. Such drawings are routinely used in the technical fields (e.g. civil and mechanical engineering) during the design process.



5.1 Different views of the same object

Mathematical notes

This section introduces the importance of being able to imagine what an object looks like from different positions.

Teaching guidelines

Although this section focuses on being able to reason from given drawings, it would be very rewarding to make some simple objects available to learners to draw (perhaps some of the paper objects they folded in Term 2 Unit 6).

You could set the learners up in small groups around a table on which you place an object. Some may lean over the object and some may sit below it (i.e. lower than the table), while others sit around it. Ask each learner to draw the object as they see it. Once all learners have done their drawings, allow them to compare them. Let the learners shift their positions to allow them to confirm the view seen by other members in the group.

Question 3 is tough. It is acceptable if learners do not get it right at this stage. Learners may return to this question once they have completed the unit.

Answers

1. Learners' own work. Elements in the learners' paragraph could include: the mug is held upside down with the ear of the mug towards the right, the mug is being turned clockwise, the mug is turned 1 fifth of a half turn from picture to picture until the mug is upright in Picture F. Allow learners to articulate themselves what it is that they see.

2. As in Picture B

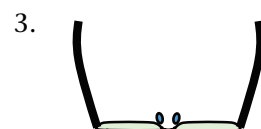

UNIT

5

VIEWING OBJECTS

5.1 Different views of the same object

1. Thandi is holding the mug on the right. Write a short paragraph to describe what you see in the pictures of the mugs on the right.



A

2. This is what you will see if Thandi holds her glasses like she is holding the mug in Picture C:



This is what you will see if Thandi holds her glasses like she is holding the mug in Picture E:



How is Thandi holding her glasses if you see them like this?



3. Make a drawing to show how you will see the glasses if Thandi holds them like she is holding the mug in Picture A.



B



C



D



E



F

5.2 What you see from different places

Mathematical notes

The ideas in the previous section are formalised here. Depending on the object being viewed, there could be certain views that are more useful than others. Top and bottom views are often very helpful, as well as side views showing different faces, or side views that show the symmetry of the object. Sometimes, however, we may have to represent an object from a less obvious position, which could result in many of the properties of the object being hidden (e.g. question 1(b) Picture 4).

Teaching guidelines

Again, time and resources permitting, allow your learners to draw actual objects and plans (in the classroom, on the playground, in the school hall, etc.). Now, however, engage them in a discussion about which positions are the most useful to show the properties of the objects, especially when it comes to faces and symmetries of the objects, and to plans of room layouts. Alternatively, talk to them about how a room's layout or an object may appear from a particular position (a greater challenge).

Answers

- (a) Picture 4
(b) Person B: Picture 3
Person E: Picture 1
Person F: Picture 2
(c)

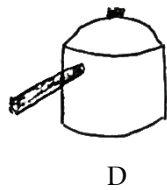

5.2 What you see from different places

- Six people are sitting at positions A, B, C, D, E and F around a table.



- Which picture shows how the person at A sees the pot?
- Which pictures show how the people at B, E and F see the pot?



Picture 1



Picture 2



Picture 3



Picture 4

- Make drawings of how the people at C and D see the pot.

Teaching guidelines

Allow learners to explain their answers for question 2 to each other. It will be important for you to observe the kind of descriptions that they are giving.

Answers

2. (a) Piet is standing at A.
(b) Jaamiah is standing at C.
(c) Tebogo is standing at B.

This is a **plan** of the dining room in the house of Mr Phosa.

A plan shows how something looks from above, like a bird that flies and looks down would see it.

There are doors at A and B, and a window at C.

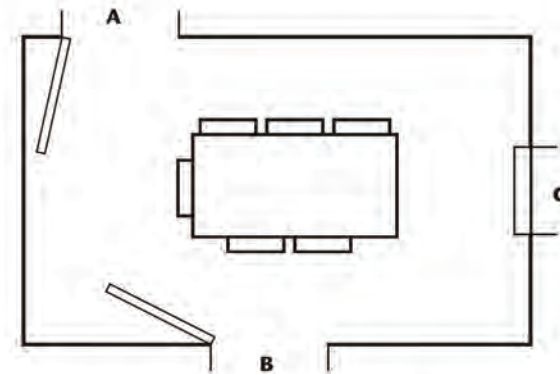

2. Tebogo, Piet and Jaamiah are standing at the doors and the window.
- (a) Picture 1 shows what Piet sees. Where is he standing?
(b) Picture 2 shows what Jaamiah sees. Where is she standing?
(c) Picture 3 shows what Tebogo sees. Where is she standing?

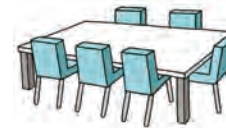

Picture 1



Picture 2



Picture 3

Learner Book Overview		
Sections in this unit	Content	Pages in Learner Book
6.1 Draw figures on grid paper	Making the case for the need for tools to make good drawings of shapes	236 to 237
6.2 Figures with equal sides and right angles	Exploring the possibilities resulting from these two requirements	238 to 239
6.3 Figures inside circles	Drawing circles, choosing points on them and joining them to form polygons	240 to 241

CAPS time allocation	4 hours
CAPS page references	21 to 22 and 184

Mathematical background

The issue of how to draw good copies of given shapes may have arisen in your class in Term 1 Unit 8 (Section 8.5). Even if it did not, at this point some of your learners may be asking how they can draw better versions of shapes. This is the focus of Section 6.1. One way is to make use of square grid paper.

The requirement “shapes with equal sides and right angles” is raised in Section 6.2. By a process of elimination learners are led to the conclusion that only squares fit the bill. The *process* of coming to this conclusion is important. Many mathematical ideas are discovered by asking a simple question and investigating the possibilities that result. So, do not refer to squares or any specific polygons while learners are going through this process.

In Section 6.3, the usefulness of circles in drawing certain polygons is introduced. If one draws a circle and marks off some points on its circumference and then joins these points with straight lines, polygons are formed. This is an important germ idea that leads to a great deal of important mathematics later. This introduction will focus on drawing squares, rectangles and regular hexagons.

Resources

Square grid paper (see pages 412 and 413 in the Addendum); loose sheets of paper; round objects such as tins, small lids or saucers (see Section 6.3 on page 264 of this Teacher Guide)

6.1 Draw figures on grid paper

Mathematical notes

This section focuses on drawing polygons (primarily triangles and quadrilaterals) on square grid paper. Often the angles at the corners of polygons drawn on such a grid can easily be checked to see if they are smaller than right angles, bigger than right angles or exactly right angles.

Mathematics often involves finding out what sorts of things meet a set of mathematical conditions. Finding out usually takes time and several attempts. Mathematics is not always about knowing the answer quickly, nor about always knowing immediately how to work out the answer. Sometimes a lot of mathematics is learnt through trial and error.

Teaching guidelines

The material in this section is sophisticated, because learners are asked to decide whether a given figure meets some conditions (question 2). Learners are also asked to try to draw figures with certain conditions or characteristics (questions 1 and 3). Sometimes it is not possible to draw figures with the required conditions. Allow your learners to work through these conditions carefully. Resist the temptation to help them to the “answer”. Explain to them that they are not expected to know the answers straightaway and that they should expect to make several attempts before drawing an answer or reaching a conclusion. Support learners’ struggles by engaging them in conversation that allows them to make headway under as much of their own power as possible. They will benefit greatly from the experience.

In question 2 learners use grid paper to help them decide whether a figure meets certain conditions. In question 3 they use grid paper to draw figures that must have a particular set of characteristics. If you have access to the internet, you can download and print copies of grid paper. You could also photocopy the grid paper provided in the Addendum on page 412 or 413, or you could remind learners how they were shown to make their own grid paper on page 102 of the Grade 4 Learner Book (see the extract alongside).

Answers

- (a) to (e) Learners’ own drawings

8.3 Make drawings on grid paper

- You need to make grid paper before you can do the next task.

Use your ruler and a sharp pencil as shown here, to make a grid on a whole clean page of ruled paper.

Your grid should consist of small squares, as shown below.

You will need at least three sheets of grid paper.

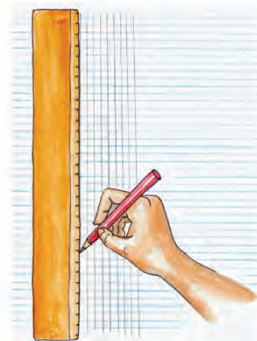

UNIT

6

PROPERTIES OF TWO-DIMENSIONAL SHAPES

6.1 Draw figures on grid paper

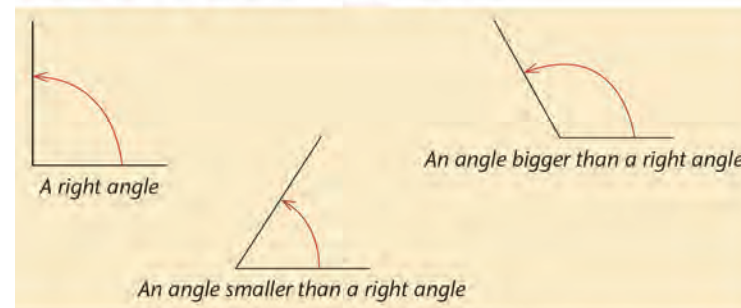

- Use a ruler or any other object with a straight edge to draw each of the following figures on blank paper:
 - a triangle with one angle bigger than a right angle
 - a triangle with all three angles smaller than a right angle
 - a quadrilateral with no right angles
 - a quadrilateral with four right angles
 - a pentagon with all angles bigger than right angles

It is easy to draw a neat triangle or quadrilateral on blank paper with a ruler, if the angles are different.

It is not so easy to draw a figure with equal angles.

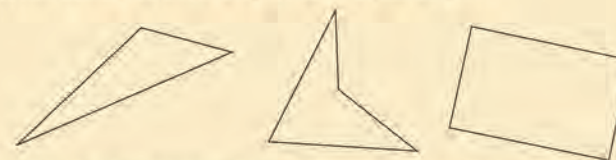

It is easier to draw figures with right angles on grid paper than on blank paper.

236

UNIT 6: PROPERTIES OF TWO-DIMENSIONAL SHAPES

Answers

2. (a) The red quadrilateral
(b) The black quadrilateral
3. (a) Impossible
(b) Learners' own drawings; these may differ.
(c) Impossible
(d) Learners' own drawings; these may differ.
(e) Impossible
(f) Impossible

You can make your own grid paper by drawing vertical lines on ruled paper. Your vertical lines must be the same distance from each other as the lines on the ruled paper are.

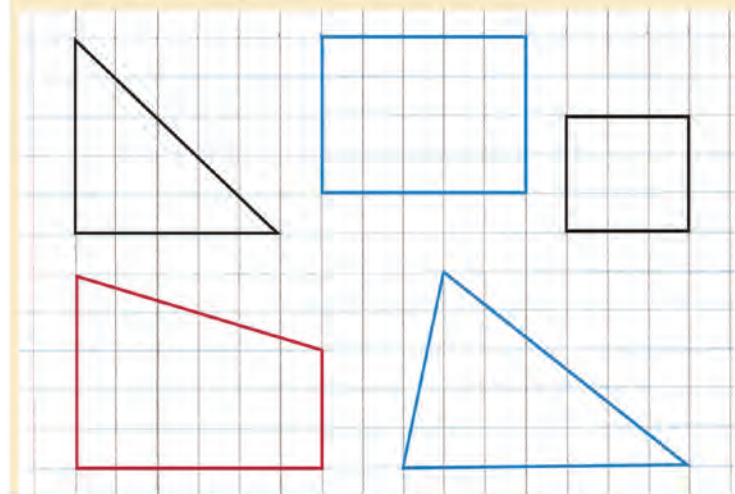

The black triangle above has only one right angle. It has two angles that are smaller than right angles.

2. (a) Which quadrilateral above has only two right angles?
(b) Which quadrilateral has four equal sides?
3. Try to draw the figures described below. Use grid paper. If you find that it is impossible, state it in writing.
 - (a) a triangle with two right angles
 - (b) a quadrilateral with only one right angle
 - (c) a quadrilateral with only three right angles
 - (d) a triangle with three angles all smaller than a right angle
 - (e) a quadrilateral with four angles all smaller than a right angle
 - (f) a quadrilateral with four angles all bigger than a right angle

6.2 Figures with equal sides and right angles

Mathematical notes

As mentioned in Section 6.1, mathematics often involves finding out what sorts of things meet a set of mathematical conditions. This section offers examples of such problems.

The only two-dimensional shapes that have equal sides and right angles only are squares. But do not tell your learners this until the end of the section.

The definitions of rectangles and squares are quite sophisticated. A rectangle is any quadrilateral with four equal angles. These are always right angles. According to this definition a square is also a rectangle: all squares have four right angles. So it makes sense to define squares as rectangles with four equal sides.

Possible misconceptions

Some learners will resist the idea of a square being a special rectangle. The issue here is: “Does a square have four equal angles?” Well, yes. “Does a square have other characteristics that rectangles do not have in general?” Yes, its sides are equal. Then a square must be a special rectangle, one with four equal sides. Part of the problem is that many learners have been taught that a rectangle is a shape with two long sides and two short sides. This is not a good definition of a rectangle.

Teaching guidelines

You can start by reminding learners that although we often categorise things in the world around us into separate categories, for example dogs and cats, we do not always do this. Sometimes one grouping is a sub-grouping of another. You can give them examples where one group is a special kind of another group. You can, for example, ask them: “Are all girls people?”, “Are all people girls?”, “Are all chickens birds?”, “Are all birds chickens?”, “Is red a colour?”, “Are all colours red?” Ask them to think of other examples. Then discuss the given definitions of rectangles and ask them whether squares also have these characteristics.

Learners may find it easy to identify right angles where the sides of figures coincide with the grid lines, for example in Figures D and F. However, they may find it more difficult to identify right angles in figures where the sides do not coincide with grid lines. In these examples learners should use right-angle templates (see Learner Book page 99) to check for right angles. Learners can also check the lengths of sides in these examples by making length templates, i.e. marking off lengths on the edge of a sheet of paper.

Answers

- Four equal sides: A, B, E, F
 - Four right angles: B, D, F
 - Four equal sides and right angles: B, F
- Rectangles: B, D, F
 - Squares: B, F
 - Rectangles only: D
 - Four equal sides, but not squares: A, E

6.2 Figures with equal sides and right angles

- In this question, use your ruler only when it is really necessary.
 - Which figures below have four equal sides?
 - Which figures have four right angles?
 - Which figures have four right angles and four equal sides?

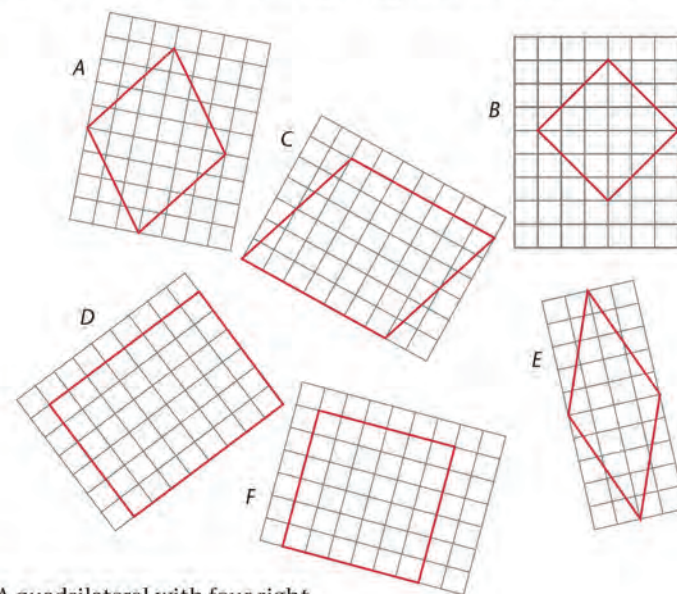

A quadrilateral with four right angles is called a **rectangle**.

A rectangle with four equal sides is called a **square**.

- Which of the above figures are rectangles?
 - Which of the above figures are squares?
 - Which of the above figures are rectangles but not squares?
 - Which of the above figures have four equal sides, but are not squares?

Teaching guidelines

Your learners may need a great deal of support to make proper sense of this section, especially from question 3 onwards. As far as possible, help learners to understand the instructions so that they attempt each question meaningfully. It is more important that learners experience making sense of instructions than rushing to get all the questions done. You can remind learners to ask themselves: “*Is there anything that I have done or seen before that can help me here?*” It is important that learners see mathematics as connected and not as isolated, disconnected bits of information.

Question 5 is a challenging question that can be used for extension. You might like to prepare for this question by trying to find some counter-examples to each statement. These will prove the statements false. However, do not teach or show these to learners; let them find examples for themselves.

Possible misconceptions

Sometimes learners think that if they find one correct answer the statement is true. This is not correct. A statement is only true if *all* possible examples of it are true. However, a statement is false if *one* example of it is false. You only have to find one counter-example to show that a statement is false.

Answers

3. (a) to (e) Learners’ own drawings; drawings will differ from learner to learner.
4. (a) to (d) Learners’ own drawings; drawings will differ from learner to learner.
5. (a) False (b) False (c) True (d) True
(e) True (f) True (g) False

3. Make drawings of the following figures on grid paper:
- (a) a rectangle with two sides longer than the other two sides
 - (b) a quadrilateral with no right angles and four equal sides
 - (c) a rectangle with four equal sides
 - (d) a pentagon with two right angles, and three angles bigger than right angles
 - (e) a pentagon with two right angles, and one angle smaller than a right angle
4. Make drawings of the following figures on grid paper:
- (a) a quadrilateral with three right angles
 - (b) a quadrilateral with only two right angles
 - (c) a quadrilateral with only one right angle
 - (d) a quadrilateral with no right angles and no equal sides
5. Which of the statements below are false, and which statements could be true?
It may help you to think about what you did in question 4. In some cases you may need to make new drawings.
- (a) If a quadrilateral has only two right angles, the other two angles are both smaller than right angles.
 - (b) If a quadrilateral has only two right angles, the other two angles are both bigger than right angles.
 - (c) If a quadrilateral has only two right angles, one of the other angles is smaller than a right angle.
 - (d) If a quadrilateral has only one right angle, one or two of the other angles are smaller than right angles.
 - (e) If all the angles of a figure with straight sides are right angles, it is definitely a quadrilateral.
 - (f) If one angle of a quadrilateral is smaller than a right angle, then one or more of the other angles are bigger than right angles.
 - (g) If one angle of a triangle is smaller than a right angle, then one of the other angles is definitely bigger than a right angle.

6.3 Figures inside circles

Mathematical notes

This section is about using circles as tools to draw polygons. In particular, this section is about squares, rectangles and regular hexagons.

Teaching guidelines

Because learners will need to fold their initial circle to find its centre, it is better if they do this section on loose sheets of paper. The sheets should be pasted into their exercise books afterwards.

Some learners may identify the figures in questions 1(e) and 2(c) by sight. If learners cannot identify the figures by sight, ask them questions such as: “What kinds of quadrilaterals do you know?”, “What properties do the quadrilaterals you have listed have?”, “How can you check or test to see whether these quadrilaterals meet these conditions?”

Answers

- (a) to (d) Learners’ own work
(e) Square
- (a) and (b) Learners’ own work
(c) Rectangle

6.3 Figures inside circles

- Use a glass or a tin or some other round object to draw a circle in the middle of a loose sheet of paper.
 - Fold the sheet so that the fold divides the circle into two equal halves.
 - Fold the sheet again so that the circle is divided into four equal quarters.
 - Draw lines between the four points where the fold lines pass through the circle.
 - What kind of figure is formed?

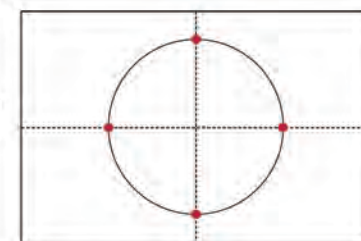
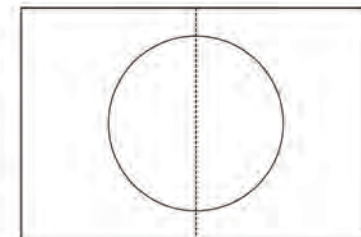

- Draw another circle, and draw two lines through its centre (middle) as shown on the right.
 - Draw lines between the points where your lines meet the circle.
 - What kind of figure is formed?

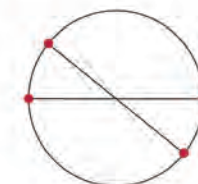

A **regular hexagon** has six equal sides and six equal angles.

A circle can be drawn tightly around a regular hexagon.

You can follow the instructions on the next page to draw a regular hexagon accurately.

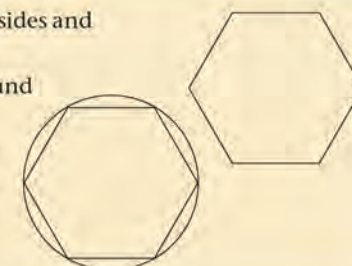

Answers

3. (a) to (f) Learners' own work

3. Follow the instructions to draw a regular hexagon accurately.

(a) Use a round object to draw a circle in the middle of a clean sheet of paper.

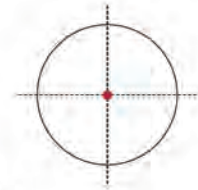

(b) Fold the sheet twice to find the centre of the circle.

(c) Draw another circle that passes through the centre of the first circle.

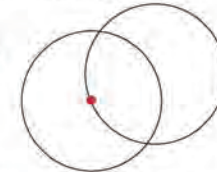

(d) Your two circles meet in two points. Draw a third circle that passes through one of these points, and the centre of your first circle.

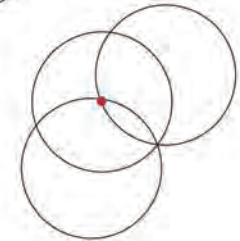

(e) Draw another circle in this way so that your drawing looks like this. Mark the midpoints of the three outer circles as accurately as you can.

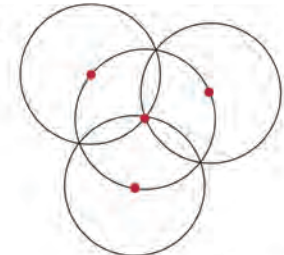

(f) Draw lines between points on your first circle to form the regular hexagon.

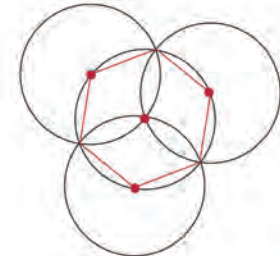

Learner Book Overview		
Sections in this unit	Content	Pages in Learner Book
7.1 Making patterns by moving a shape	Introducing rotations, translations and reflections	242 to 244
7.2 Rotations	Taking a closer look at rotations	245 to 247
7.3 Reflections and translations	Taking a closer look at reflections and translations	248 to 251

CAPS time allocation	3 hours
CAPS page references	23 and 185

Mathematical background

Any relocation of a shape can be achieved by a combination of three types of movement, called “transformations”:

- shifting (translating) it in a particular direction, through a particular distance, without rotating it
- swinging (rotating) it around a particular point outside or on the shape, through a particular angle
- flipping it over (reflecting it), i.e. picking it up, turning it over and placing it down again.

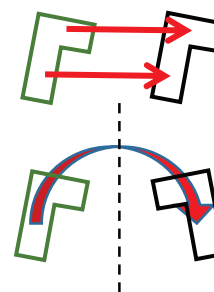
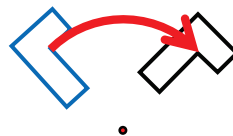

Reflecting a shape always produces symmetry. The axis of reflection (the broken line in the above figure) is the line of symmetry.

If two identical shapes lie on the same flat surface it is always possible to get one of the two shapes to fit exactly on top of the other by performing a translation, rotation or reflection, or a translation and a reflection (a so-called “glide-reflection”).

Translations, rotations and reflections do not change the form or size of a shape. Other kinds of transformations, for example enlargements, do change the size. There are also transformations that change the shape, such as stretching in one direction.

Patterns are formed when the same transformation or set of transformations is repeatedly applied to the same shape, for example:

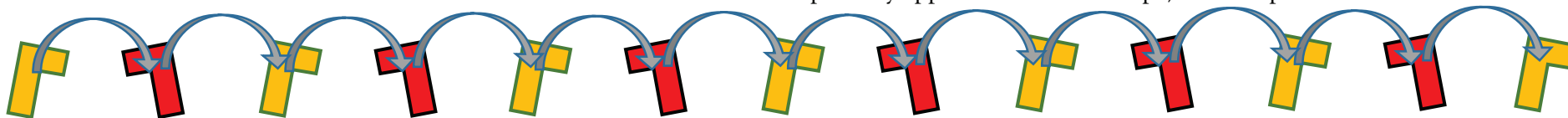

Resources

Loose sheets of paper, cardboard (e.g. from tissue or cereal boxes), glue, scissors, pins

7.1 Making patterns by moving a shape

Mathematical notes

This section is about exploring the three basic transformations before they are identified and defined towards the end of the section.

Teaching guidelines

It is important to first give learners the opportunity to find their own words to describe the different transformations of the shape (glass tile) in Patterns A, B and C. Ensure that your learners engage meaningfully with the activities. Resist the temptation to jump ahead and tell them about translations, rotations and reflections. Allow them to struggle with describing the patterns.

Describing their own observation of how the position of a shape is changed is an important part of developing an understanding of the different transformations.

It is very important that learners actually write down their attempts to describe the three patterns. (They will return to these descriptions and try to improve them at the end of the section when they do question 7.)

If time permits, it would be valuable if learners could tell each other in small groups or pairs how they described the patterns.

Answers

You cannot expect learners to use the terms translation, reflection and rotation when they respond to question 1. It will be very valuable for you to read or listen to as many of the learners' answers as possible, but it makes no sense to try to assess their answers. The question serves to get learners to begin to form language that can be used to describe the patterns. Some of the things learners *may* say are given below.

1. (a) Pattern A: The tile is repeated five more times; it is simply moved along a straight line towards the right.
Pattern B: The tile is also repeated, but it is only repeated four more times. However, it is not simply moved along as in Pattern A but turned to the right each time in such a way that after the first and third turns, it is rests on one of its long sides.
- (b) Pattern A: The tile is repeated five more times; it is moved along a straight line without being turned or turned over.
Pattern C: The tile is also repeated five more times but it is turned over (flipped) each time.

UNIT
7
TRANSFORMATIONS

7.1 Making patterns by moving a shape

Each of the three patterns below was made by moving this colourful glass tile in a certain way.
You will soon learn to see how the tile was moved to make each of the patterns.





Pattern A



Pattern B



Pattern C

1. (a) Describe how Patterns A and B differ from each other.
(b) Describe how Patterns A and C differ from each other.

242
UNIT 7: TRANSFORMATIONS

Teaching guidelines

You will need a larger template with the same shape to do the questions on the board at some stage during the lesson.

Learners may focus primarily on putting the template down into each of the positions without being aware of how they may move the template from the position on the left to the position on the right in each question.

Learners may manage to move the template from the positions on the left to the positions on the right in many ways, and they will not necessarily become aware of the simple movements: slide along a straight line (translate), swing around a point (turn, rotate) and turn over (reflect) in a line.

After learners have engaged with questions 3 to 5 on their own, tell them that the questions can be done with very simple movements. Then demonstrate on the board that question 3 can be done by keeping your elbow fixed at a point some distance below and between the two positions, and swinging the template from the one position to the other.

Similarly demonstrate that for question 4 the template can be slid in a fixed direction without turning it, but that for question 5 you have to lift the template off the board and turn it over to land on the second position.

Ask learners to copy your movements for the three questions. You may have to repeat the demonstrations on the board a few times. Continue until all learners get it right. Only then ask them to do question 6. Do not provide them with terms that may be used to describe the three kinds of movement: allow learners to come up with their own ways of describing the movements.

Learners may find question 6 challenging. It is quite important that they persevere and manage to write some descriptions of the three kinds of movement down. The attempt to describe the movements in words will support the formation of the concepts of translation, rotation and reflection in their minds.

Answers

2. to 5. Learners' own work

6. Refer to "Teaching guidelines" above; guide the learners to find the correct articulation.

2. Draw a copy of this shape, and cut it out. Do not spend much time; your copy need not look exactly like this.

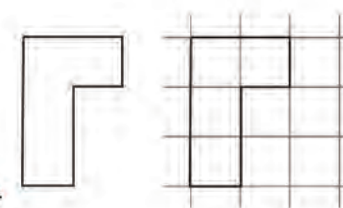

The piece of paper that you have cut out is called a **template**.

3. (a) Put your template on the figure on the left, so that it fits.

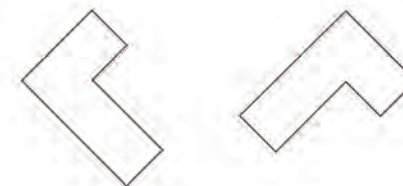

- (b) Move your template to the figure on the right so that it fits, without picking it up.

4. (a) Put your template on the figure on the left, so that it fits.

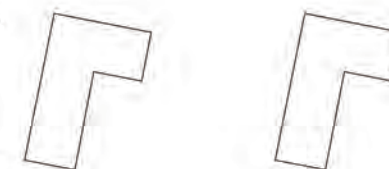

- (b) Move your template to the figure on the right so that it fits, without picking it up.

5. (a) Put your template on the figure on the left below, so that it fits.



- (b) Move your template to the figure on the right so that it fits.

6. Describe the different ways in which you moved your template when you did questions 3(b), 4(b) and 5(b).

Teaching guidelines

Demonstrate questions 3, 4 and 5 again and now tell learners what the three kinds of movement are called: rotation, translation and reflection.

For homework or additional practice, you may ask learners to try to improve their answers for question 1.

Answers

7. (a) Pattern B
(b) Pattern C
(c) Pattern A

To move the template from the position on the left to the position on the right you can swing or **rotate** the template.

The black figure is called a **rotation** of the blue figure.



To move the template from the position on the left to the position on the right you can slide the template without turning it.

We say we **translate** the template.

This black figure is called a **translation** of the blue figure.

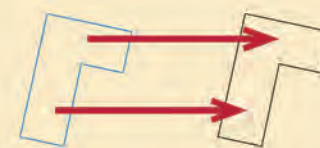

To move the template from the position on the left to the position on the right you can pick the template up and flip it over.

We say we **reflect** the template.

This black figure is called a **reflection** of the blue figure.

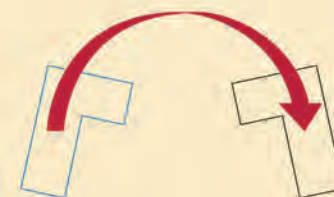

7. Look again at your answers for question 1.
- (a) Which of the three patterns can be made by repeatedly rotating the glass tile?
- (b) Which of the three patterns can be made by repeatedly reflecting the glass tile?
- (c) Which of the three patterns can be made by repeatedly translating the glass tile?

7.2 Rotations

Mathematical notes

Rotations involve turning a shape around a fixed point (the centre of rotation).

Teaching guidelines

The **rotation tool** is very useful in getting the key properties of rotations across to your learners: there is a point around which rotations occur, and the rotated shapes are all the same distance from that point. Perhaps it would be wise to make other rotation tools available (with other shapes). The value of this tool is that your learners will *do* rotations instead of just looking at them.

For enrichment, in question 5 you may repeat the triangle rotation activity in two other ways:

- First, make a small hole in the triangle and pin the triangle to the page. Rotate it and draw the triangle in a number of positions.
- Second, glue a strip of cardboard to the triangle and make a hole at the end furthest from the triangle. Pin it through the hole and rotate, drawing the triangle in a number of positions. This activity will highlight to learners that a centre of rotation can be in many positions.

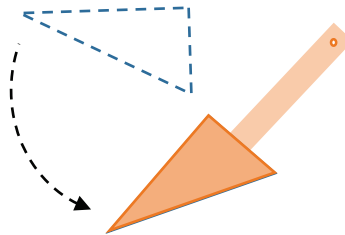

Possible misconceptions

There is a risk that learners will confuse the three types of transformation. Ask them if any of the drawings they made have translations or reflections in them. A short discussion should lead to a general consensus that rotations do not involve reflections or translations of the shapes they have used in questions 1 to 6.

Answers

2. (b) Circle

7.2 Rotations

1. Follow the steps below to make a **rotation tool** that you can use to draw rotations of a pentagon like this.

Trace a copy of the diagram below onto a piece of cardboard or thick paper.

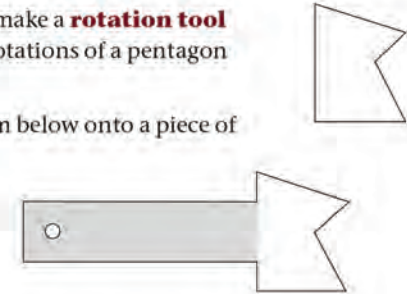

Cut it out.

Make a small hole at the one end of the strip as shown in the diagram.

If you press your pencil tip through the small hole onto a blank sheet of paper, you can swing the pentagon around the pencil.

2. Do this activity with a classmate. You need two pencils and a blank sheet of paper.

- (a) Pin the rotation tool to the middle of the paper with one of the pencils. Trace around the pentagon using the other pencil.

Swing the pentagon to a different position. Trace around the pentagon to show the new position.

Repeat as many times as you can fit in the pentagon.

- (b) What shape can be formed by rotating the pentagon many times?

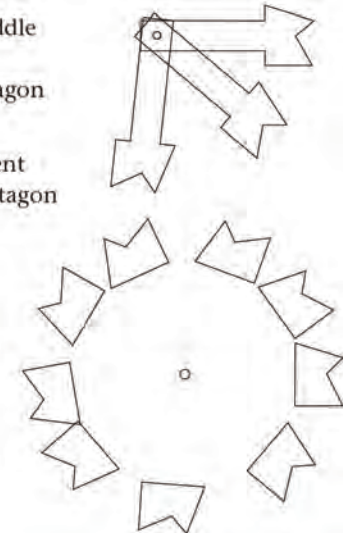

A 2-D figure that consists of more than one figure is called a **composite figure**.

Notes on questions

You can ask learners to first familiarise themselves with the given pentagon. This will allow them to notice the different side lengths in order to identify the specific transformations in Figures A to E. Learners must be given the opportunity to find the words to describe the transformations they observe. Refer them to the description of the different transformations on page 244.

Answers

3. Figure A: 3 times Figure B: 4 times
Figure C: 7 times Figure D: 3 times
4. (a) The rotation in the two figures is the same, but in Figure E the pentagons are also reflected.
- (b) Learners' own work, for example:
Pin the rotation tool to the middle of a sheet of paper. Trace around the pentagon. Unpin the rotation tool, turn it over (reflect it) and re-pin it with the pin in the same as position as before. Turn the rotation tool a bit to the right (or the left, if you prefer) and trace around the pentagon. Repeat six more times, always working in the same direction.
- (c) Learners' own work

3. How many times do you have to rotate the pentagon to make the composite figures A, B, C and D below?

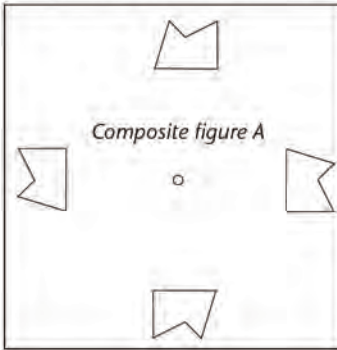

Composite figure A

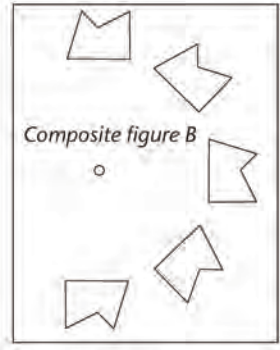

Composite figure B

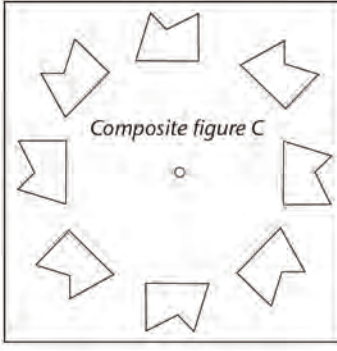

Composite figure C

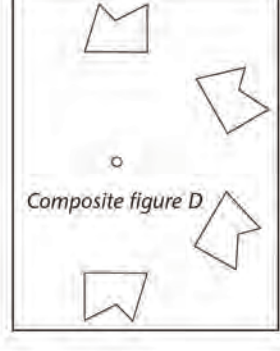

Composite figure D

4. (a) How do the composite figures C (above) and E (on the right) differ?

(b) Describe how you will use your rotation tool to draw a composite figure like E.

(c) Draw the figure.

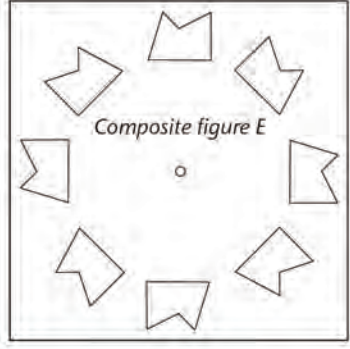

Composite figure E

246 UNIT 7: TRANSFORMATIONS

Teaching guidelines

You may advise learners who experience difficulties with questions 6(b), (c) and (d) to move their cut-out triangle on the coloured drawing, to try to figure out what the answers to the questions are.

Answers

5. Learners' own work
6. (a) Learners' own work
- (b) The yellow triangle is a translation of the red triangle.
- (c) Yes, combined with a translation.
- (d) No, it is a reflection combined with a translation.

5. You will now draw rotations of a triangle without a rotation tool.

Cut a triangle from paper or cardboard.

Make a dot in the middle of a sheet of paper.

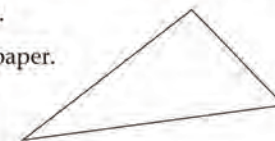

Put one corner of your triangle next to the dot and trace the triangle.



Put your triangle in a different position, with the same corner next to the dot.

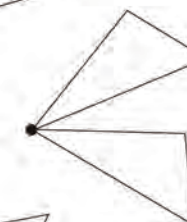

Trace the triangle again.

Repeat the above actions to draw a composite figure with several rotations of the triangle, like this.

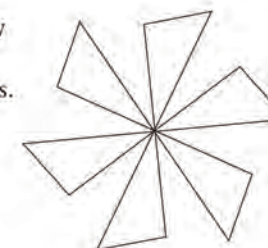

6. (a) Use the triangle you have cut out to draw a composite figure like the one below.

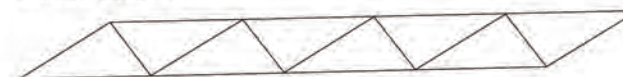

- (b) Is the yellow triangle below a rotation of the red triangle? If not, is it a translation or is it a reflection?



- (c) Is the yellow triangle a rotation of the blue triangle?
- (d) Is the blue triangle a rotation of the red triangle?

7.3 Reflections and translations

Mathematical notes

This section aims to clarify the special characteristics of translations and reflections. Translations involve moving a shape from one position to another without changing its orientation. Reflections involve flipping a shape over a line of symmetry.

Teaching guidelines

A **reflection tool** is introduced. It is a piece of paper folded in half. The fold is the line of symmetry. A shape is drawn on one side of the fold and “transferred” with pinpricks to the other side, creating a mirror image.

A **translation tool** is also introduced. It is a piece of paper with a shape on it that is shifted along a line on a sheet of paper to another position where the shape is transferred by pin pricks.

As with the rotation tool in Section 7.2, the aim is to give learners a chance of *doing* the transformation, and not just seeing it. Give them ample time to do so meaningfully. Their understanding of the three transformations will be richer for it.

Possible misconceptions

Ask learners questions such as: “*Can a rotation of this shape ever be the same as a reflection of the same shape?*”, “*Can a translation ever be a rotation?*”

Note: With most shapes, the three transformations are quite different. However, with some, for example circles, a translation could be seen as a rotation or as a reflection. This has to do with the perfectly regular/smooth shape of a circle. When it comes to transformations of an individual point, the same is true. In general, however, the three transformations behave differently.

Answers

- (a) to (d) Learner’s own work
- (a) The blue hexagon
(b) The blue hexagon and the black hexagon

7.3 Reflections and translations

- Follow these instructions to draw a reflection of a quadrilateral.

You need a pencil with a sharp tip.

- Fold a sheet of paper in half, and draw a quadrilateral on one side.
- Use the tip of your pencil to punch four small holes at the corners of your quadrilateral. The holes must go through both layers of paper.

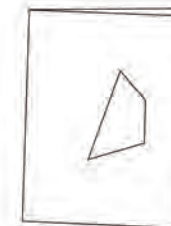

- When you open up the sheet you can see your drawing on the one half of the sheet, and the four holes on the other half. You can also see the fold line.

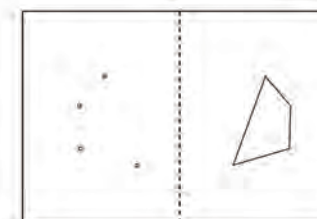

- Draw lines from one hole to the next. In doing so, you are drawing a reflection of the first quadrilateral that you drew.

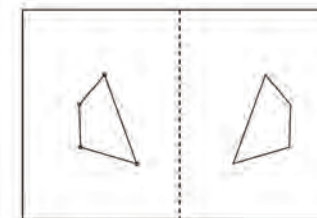

- The yellow hexagon below is a translation of the black hexagon.

- Which hexagon is a reflection of the black hexagon?
- Which hexagon is a rotation of the red hexagon?



Answers

3. Learners' own work
4. (a) to (e) Learners' own work

3. Draw a hexagon on a rectangular piece of paper about this size, and punch small holes at the six corners of the hexagon.

You will use this template to draw translations, reflections and rotations.

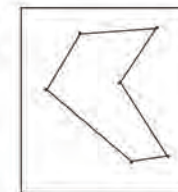

4. Follow these instructions to draw translations of the hexagon on your template.
 - (a) Draw a straight line across the width of a blank sheet of paper.
 - (b) Put the bottom edge of your template against the line as shown below.

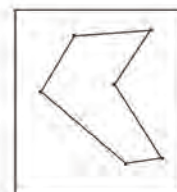

- (c) Make marks through the six holes, so that you can later draw a copy of the hexagon by joining the marks with lines.
 - (d) Slide your template to a new position, but keep the bottom edge against the line that you have drawn.

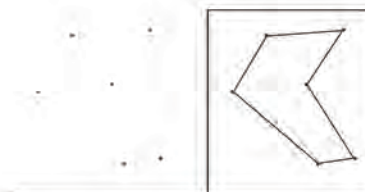

- (e) Make marks through the six holes again, for another copy of the hexagon.

Answers

4. (f) Learners' own work
5. Learners' own work
6. No. It has to be reflected in a vertical line of symmetry.
7. Learners' own work
8. The pattern can be made by a rotation together with a reflection of the hexagon.

(f) Continue to slide the template and make marks through the holes, until you have reached the end of your line.

Join the six marks you made in each position of the template, to draw translations of the hexagon.

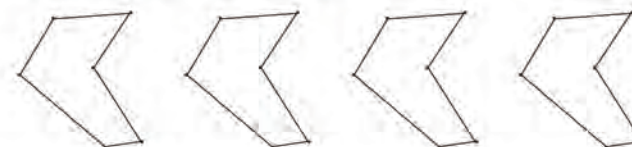

5. Use your hexagon template to draw a reflection of the hexagon.

It will be helpful to trace all around the edges of the template too.

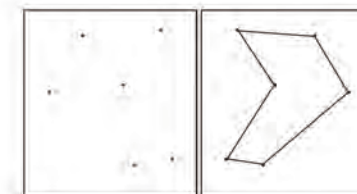

The pattern below can be made by reflecting a hexagon many times:

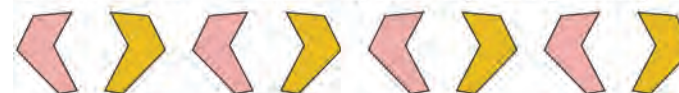

6. Can this pattern also be made by translating hexagons? Describe how this can be done.

7. Use your hexagon template to draw a rotation of the hexagon.

It will again be helpful to trace around the template too.

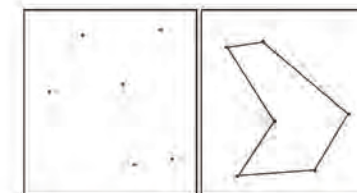

8. How can this pattern be made?



Answers

9. Translation

10. (a) Reflection
(c) Rotation
(e) Rotation

11. (a) Figure A
(c) Figures A and B

- (b) Reflection
(d) Reflection
(f) Reflection

- (b) Figures A and B
(d) Figures A and C

Translations, rotations and reflections are three different types of **transformations**.

9. To make the pattern below, the hexagon template was first translated, then rotated, and then reflected.



Which transformation was used to move the template from D to E?

10. Which transformation can be used for each of the following movements of the hexagon in the above pattern?
(a) from E to F (b) from F to G
(c) from G to H (d) from A to H
(e) from F to B (f) from B to H

11. Three figures are shown below.

- (a) In which of the figures is the red pentagon a reflection of the black pentagon?
(b) In which figures is the yellow pentagon a rotation of the black pentagon?
(c) In which figures is the blue pentagon a rotation of the red pentagon?

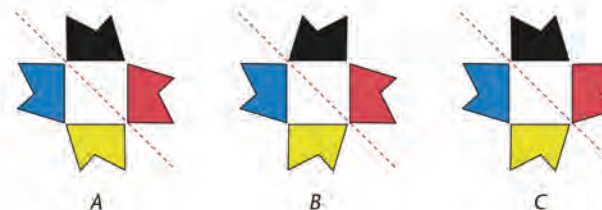

- (d) In which figures is the red broken line a line of symmetry?

Learner Book Overview		
Sections in this unit	Content	Pages in Learner Book
8.1 Estimating and measuring temperature	Getting a feel for hot and cold temperatures and how to read the scale of a medical thermometer	252 to 254
8.2 Weather temperatures	Working with the high and low temperatures in different cities in South Africa	255 to 256

CAPS time allocation	2 hours
CAPS page references	28 and 186

Mathematical background

In Term 2 we saw that a unit of length is very useful when we need to tell someone, for example, how long a piece of dress material must be. If everyone agrees on the same unit of measurement, then people can communicate without getting confused.

In the same way we can communicate about temperature if everyone agrees on a unit of temperature – the degree Celsius ($^{\circ}\text{C}$). Then everyone can understand a recipe book that says “heat the oven to 140°C ”.

The mathematics involves the following:

- reading scales on thermometers, marked in degrees
- understanding fractions of a degree
- recording and reporting on temperature measurements
- understanding that each type of thermometer has a temperature range; most thermometers cannot measure very high or very low temperatures.

We can subtract temperatures to find differences, which tell us how much a temperature has increased or decreased. We cannot add temperatures. (If we have a cup of hot water at 60°C and another at 40°C , and we pour the water into a jug, we don't get water at 100°C .) We also don't multiply a temperature by a temperature, nor divide a temperature by a temperature.

Resources

Long thermometer from the school's science kit, if available; smartphone, if available

8.1 Estimating and measuring temperature

Teaching guidelines

You should do some language work on this text.

Ask learners to give examples of *the environment*. The environment is all of the world around us, excluding us. So the learners' desks and books are part of their environment, and so are the walls of the classroom and the air in the classroom. For each learner, the other people around him/her are part of his/her environment.

A *sealed* glass tube is a hollow tube, like a plastic or paper straw, that has been melted in a hot flame so that it is closed or *sealed*.

Try to borrow a long thermometer from the school's science kit. Show it to the learners. They should see the liquid inside the glass tube, and see that most of the liquid is in the pointy end, called the *bulb*.

Notice that the markings go from minus 10 °C up to 110 °C; this is called the *range* of the scale: -10 to 110 °C. (Some thermometers only go up to 50 °C.)

The liquid inside the tube is usually red-coloured alcohol. When the liquid gets hot, it gets bigger (it *expands*) and it pushes along the tube. For example, if you hold the bulb in your fist, it warms up until it is at the same temperature as your skin.

When learners are looking at the thermometer, it is showing the temperature of the air in the classroom. If they put it into a cup of hot tea, the liquid expands until it shows the temperature of the tea.

Thermometers work if they are on their sides or if they are held upright. Try this with a real thermometer.

Answers

1. to 4. Practical activity

UNIT

8

TEMPERATURE

8.1 Estimating and measuring temperature

When we say "it is cold" or "it is hot" we talk about **temperature**. We are comfortable when the weather is not too hot and not too cold.

When we say "it is cold today", it is because our bodies are warmer than the environment. When we complain that it is too hot, it is because our bodies are colder than the environment.

When water gets very cold, it freezes to become ice. When water gets very hot, it boils.

1. Rub the palm of your one hand with a finger from your other hand. Rub hard until you feel your skin burn slightly. The rubbing makes your skin warmer.
2. Take a book from your bag. Is it colder or warmer than your hand?
3. When does ice melt faster outside, on a warm day or on a cold day?
4. When does boiled water cool down faster, on a warm day or on a cool day?

In South Africa we usually measure temperature in units called **degrees Celsius** (we write °C).

Water boils when its temperature is close to 100 °C.

When you are healthy, your body temperature is about 37 °C.

The temperature in a home refrigerator is about 5 °C.

Water freezes when its temperature is about 0 °C.

Except when it gets colder than when water freezes, the temperature of the environment varies between 0 °C and 50 °C. The environmental temperature is pleasant when it is between 20 °C and 30 °C.

We use a **thermometer** to measure temperature accurately. There are many different thermometers.

"Thermo" means heat.

One type of thermometer consists of a sealed glass tube that contains a liquid, such as mercury, that rises (expands) or falls (contracts) with temperature changes.

Teaching guidelines

The picture shows a real medical thermometer and the scale is not easy to read. Some learners might be completely lost and unhappy. So, before you ask for the answer to question 5, spend a few minutes helping learners to study the picture. Ask them, what is the number that they see to the right of the 35? (Answer: It is a 6.)

What is the next number they see? (Answer: 37, and it has a black arrow in the middle. We'll explain later what this arrow means.)

What are the next three numbers? (Answer: 8, 9 and 40.)

This looks like a strange sort of scale; we expect it to go 35, 36, 37, 38, 39, 40.

The reason why some digits are missing is that there was not enough space on the thermometer to print them all – i.e. more print (digits) would have made it more difficult to read the scale. So the 6 really means 36, the 8 means 38 and the 9 means 39.

Then we see 40. Now ask learners to work out what the last number on the scale is. The answer is 42°C .

Why spend time on studying the picture? Well, you are showing learners that when they meet a picture or diagram that is hard to understand, they should not give up and think: “I can't do this.” Often they will be able to work out what information is missing in a strange diagram.

Answers

5. (a) 42°C
(b) Doctors and nurses use medical thermometers. They know that a living person cannot have a temperature lower than 35°C . Also, they know that if a person's temperature is as high as 42°C the person is very, very sick with a fever. If his temperature goes past 42°C , he or she will die.
6. (a) A: 36°C B: $41\frac{1}{2}^{\circ}\text{C}$ C: $39\frac{9}{10}^{\circ}\text{C}$
D: $37\frac{1}{2}^{\circ}\text{C}$ E: $38\frac{4}{10}^{\circ}\text{C}$ F: $41\frac{7}{10}^{\circ}\text{C}$
(b) A: 36°C B: 42°C C: 40°C
D: 38°C E: 38°C F: 42°C

Each thermometer has a scale which is marked in equal intervals, from the lowest temperature to the highest temperature that it can measure.



This is an example of a medical thermometer

This thermometer shows a temperature of 37°C . If a patient has a temperature of, for example, $37\frac{1}{2}^{\circ}\text{C}$ we can round off the temperature to the nearest degree and then say that the patient has a temperature of about 38°C .

5. (a) The minimum mark on the medical thermometer above is 35°C . What is the maximum mark on this thermometer?
(b) Why does a medical thermometer measure temperature only between these numbers?

6. (a) Read the temperatures in degrees Celsius on these thermometers. Write the temperatures in fraction notation where necessary.

Examples

$$37\frac{1}{2}^{\circ}\text{C} \quad 38\frac{6}{10}^{\circ}\text{C}$$



Answers

7. (a) $36^{\circ}\text{C} = \text{A}$
 (b) $35^{\circ}\text{C} = \text{E}$
 (c) $39\frac{1}{2}^{\circ}\text{C} = \text{H}$
 (d) $37\frac{1}{10}^{\circ}\text{C} = \text{F}$
 (e) $41\frac{8}{10}^{\circ}\text{C} = \text{J}$
 (f) $40\frac{1}{2}^{\circ}\text{C} = \text{C}$
 (g) two degrees below $40^{\circ}\text{C} = 38^{\circ}\text{C} = \text{B}$
 (h) three and a half degrees higher than $35\frac{1}{2}^{\circ}\text{C} = 39^{\circ}\text{C} = \text{G}$
 (i) $40\frac{1}{4}^{\circ}\text{C} = \text{I}$
 (j) $41^{\circ}\text{C} = \text{D}$

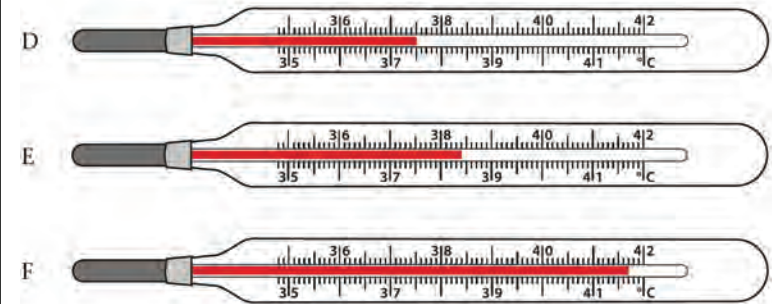

7. Where will the fluid in the tube (the red line) be at each of the following temperatures? Match each temperature with one of the letters shown in the drawing below (A to J).

- (a) 36°C (b) 35°C (c) $39\frac{1}{2}^{\circ}\text{C}$
 (d) $37\frac{1}{10}^{\circ}\text{C}$ (e) $41\frac{8}{10}^{\circ}\text{C}$ (f) $40\frac{1}{2}^{\circ}\text{C}$
 (g) two degrees below 40°C
 (h) three and a half degrees higher than $35\frac{1}{2}^{\circ}\text{C}$
 (i) $40\frac{1}{4}^{\circ}\text{C}$
 (j) half a degree lower than $41\frac{1}{2}^{\circ}\text{C}$

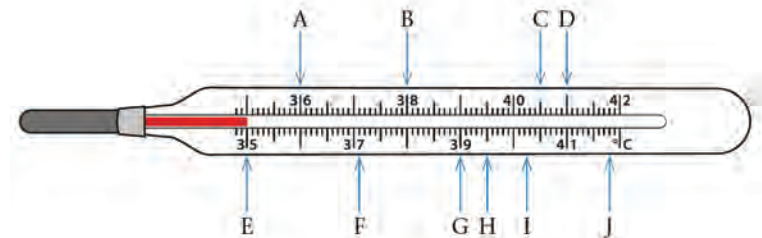

8.2 Weather temperatures

Teaching guidelines

Give learners enough time to think about their answers – ask the question and then silently count to ten by yourself before you take any answers. If you do this, you usually get better-quality answers and more thinking by the learners.

Answers

- Possible answers: People want to know whether they should put on warm clothes when they go out to school or to work. Farmers want to know whether their crops or animals will get so hot or so cold that they will suffer. People working outside want to know whether they should take water along to drink during the day.
 - The question is asking learners to estimate the temperature of the air. Learners who don't know about temperature may give very high or low estimates. Remind them of the information in the tinted passage on page 252. For example, a healthy person's temperature is about 37 °C. Answers could be anything from 25° to 42 °C. It depends on your location.
 - Answers could be anything from 20 °C down to *minus* 20 °C. It depends on your location.
 - The temperature was probably lower in the morning than it is now.
 - No, because the weather could change in the middle of the day or the middle of the night. A cold front could blow in at midday. The night-time temperature is usually lowest just before the sun comes up.
 - You can have some very cold days in summer and some very warm days in winter, so the question is really asking about average temperatures in summer and in winter.
- 3 °C
 - 5 °C
 - Upington: 18 °C
Durban: 7 °C
 - East London
 - 5 °C
 - Upington
 - Bloemfontein: 13 °C
East London: 5 °C
 - Pretoria: 14 °C

8.2 Weather temperatures

- The expected maximum and minimum temperatures for towns in South Africa are given every day on television and on the radio.
 - What do you think is the reason for giving the expected minimum and maximum temperatures?
 - What do you estimate the temperature to be on a very hot day where you live?
 - What do you estimate the temperature to be on a very cold day where you live?
 - What do you estimate the temperature was this morning when your school started? What do you think it is now?
 - Is it always the warmest at midday and the coldest at midnight?
 - Is it always the warmest in summer and the coldest in winter?

The table below shows the actual maximum and minimum temperatures on a day in January for a few towns.

	Upington	Bloemfontein	Pretoria	Durban	East London
Minimum	20 °C	19 °C	15 °C	20 °C	17 °C
Maximum	38 °C	32 °C	29 °C	27 °C	22 °C

- Compare the minimum temperatures of Durban and East London given in the table. How much colder was it in East London than in Durban on this day?
 - Compare the maximum temperatures of Durban and East London. How much warmer was it in Durban than in East London on this day?
 - Calculate the difference in temperature between the minimum and maximum for each town.
 - In which town was the difference between the minimum and maximum temperatures the smallest?
 - In which town did the temperature change the most between the minimum and maximum measurements?

Notes on questions

In question 4, learners are to record the temperature at 12 o'clock each day. Why take the air temperature at, say, 12 o'clock each day? The reason is that the temperature changes throughout the day. If we measure temperature at different times, we cannot say anything sensible about how the midday temperature changed during the days from Monday to Friday.

For this activity you will need one of those long thermometers that can measure from -10°C to 110°C . The school's science kit might have one. An alternative to a thermometer is a smartphone, if available. Some smartphones have a temperature sensor and can show you the temperature at any time.

Answers

3. (a) 3°C less than 0°C . Ask learners how that feels. What unusual things would they notice as they walk to school? (They could notice white frost on the grass and some roofs, and people breathing out white clouds of water vapour.)
- (b) 6°C
- (c) Pretoria: 19°C Durban: 11°C East London: 9°C
- (d) Durban, because the day and night temperatures are higher than in the other towns.

Learners' answers (preferences) may differ. Consider their arguments, for example:

Durban, because it has the highest day/maximum temperature.

Durban, because it is the town in which *both* the minimum and maximum temperatures are the highest.

East London, because the difference between the maximum and minimum temperatures is the smallest.

4. Practical activity

This table shows the recorded maximum and minimum temperatures on a day in July for a few towns.

	Upington	Bloemfontein	Pretoria	Durban	East London
Maximum	21°C	14°C	20°C	22°C	20°C
Minimum	4°C	-3°C	1°C	11°C	11°C

3. (a) The minimum temperature in Bloemfontein on this day was minus three degrees Celsius. What does "minus three" mean?
- (b) Compare the maximum temperatures of Bloemfontein and Pretoria. How much colder was it in Bloemfontein than in Pretoria on this day?
- (c) Calculate the increase in temperature between the minimum and maximum for Pretoria, Durban and East London.
- (d) If the temperatures in the table are typical winter temperatures for the five towns, where would you rather spend the winter? Why?
4. Record the temperature in the shade outside your classroom at 12 o'clock from Monday to Friday. Your teacher may help you. Draw the table in your book and fill in each day's temperature.

Day	Day 1	Day 2	Day 3	Day 4	Day 5
Temperature in $^{\circ}\text{C}$					

- (a) Compare the temperatures of the different days. How did the temperature change over the week?
- (b) Write the temperature readings from lowest to highest.

Learner Book Overview		
Sections in this unit	Content	Pages in Learner Book
9.1 Collecting and organising data in categories	Tally tables that compare categories The way data is grouped and represented impacts on the visibility of the trends	257 to 260
9.2 Collecting and organising numerical data	Bar graph and pictograph of the same data tell different stories Interpreting the mode	260 to 263

CAPS time allocation	9 hours
CAPS page references	30 to 31 and 187 to 188

Mathematical background

Data are bits of information about a particular context. We ask questions about a situation or context that lead to the collection of information. The way in which the data are organised and represented (and the further questions we ask) allows us to see trends in the data.

In data handling we work with large amounts of information related to particular contexts. Instead of focusing on each bit of information separately, the way we organise, represent and analyse the data gives us ways of talking in general about the data. We look at the data in a global way and draw out trends or characteristics which describe the data.

Data handling differs from other parts of Mathematics in three respects:

- **The answer to data questions is produced by analysing lots of data.**

Data handling is necessary where measurements and frequencies vary and therefore one measurement cannot provide accurate information about a situation. Lots of different data can be confusing, so we organise the data we collect in different ways to get a “picture” of the situation. Different representations make different trends more visible.

- **The numbers we use in data handling always have some description of a category they belong to or some unit of measurement.**

Learners work mostly with abstract numbers in Mathematics. In data handling, however, the numbers must be interpreted in a context. The same number 44 can be 44 learners or R44, depending on the question.

- **Data questions are always answered with a story about the context.**

Data handling starts when we need to answer a question about a situation where the property we look at varies. The numerical answers we get by data handling must be interpreted to answer the question about the situation.

9.1 Collecting and organising data in categories

Mathematical notes

The fundamental purpose of data handling is to reorganise and represent data in such a way that it becomes easier to identify properties of the data that may be useful in making decisions in practical situations.

For example, the data on page 258 is very difficult to interpret in the form in which it is given. The questions in this section provide learners with opportunities to organise and represent the data in different ways, and to experience that this makes it easier to consider options and make decisions.

Teaching guidelines

Let learners look at the table on page 258 at the start of the lesson, and ask them to make short statements that describe the data. This will make them experience that the data in this form is difficult to interpret. Tell them that while doing the questions in this section, they will learn how to organise and represent data in different ways, which will make it easier to describe the data.

Answers

1. (a)

	Tallies	Total
Male	### ### ### ### //	22
Female	### ### ### ### ### ### ### //	37
Black	### ### ### ### ### ### ### ### //	44
Blue	### ### ###	15
Zip	### ### ### ### ### ### ### ### //	42
Pullover	### ### ### //	17

- (b) Learners' reports will vary. The report should include the following information: The total sample was 59 students. There were 37 females and 22 males. Far more Grade 12s favoured black hoodies than blue hoodies: 44 students chose black hoodies and only 15 students chose blue hoodies. Hoodies with zips were much more popular (42 students' choice) than pullovers (17 students' choice).

UNIT

9

DATA HANDLING

In this unit you will organise data, and draw and interpret tables and graphs of data to understand different situations.

9.1 Collecting and organising data in categories

The Student Council at a high school raised money to make hoodies for all the Grade 12s. They gathered data by asking some Grade 12s to write down which colour they prefer (black or blue) and which style (with a zip, or a pullover).



Pullover hoodie

Hoodie with zip

On the next page are the data they gathered. Imagine that they lost the data and that you found it. You can analyse the data for them and they can give you a hoodie to say thank you!

- Your task is to use the data to determine the most popular colour and the style that the students want.
 - Make a tally table like this one to record the data in a way that will help you answer the questions.
 - Write a short report to the Student Council to say what you found.

	Tallies	Total
Male		
Female		
Black		
Blue		
Zip		
Pullover		

Mathematical notes

This table is typical of the form in which data obtained from a questionnaire may be recorded before it is analysed.

There are many ways in which the data can be reorganised to make hidden features visible. For example, separate tables can be made for males and females, and in each table all the responses that include black as the colour choice can be listed first.

Teaching guidelines

The main aim of this section is for learners to interpret and report on the data. In order to do so, they need to represent and analyse the data. More time should be spent analysing the data than counting the data in each category. You could divide the categories among learners, so that each learner tallies one category (there are six categories in question 1 and eight categories in question 3). Learners who have tallied the same categories can check their counts with each other.

Male/ Female	Colour	Style	Male/ Female	Colour	Style
F	Black	Zip	F	Blue	Zip
M	Black	Zip	F	Black	Zip
F	Black	Zip	F	Black	Zip
F	Black	Zip	M	Black	Pullover
F	Black	Zip	M	Black	Zip
M	Blue	Pullover	M	Black	Pullover
F	Black	Zip	F	Blue	Zip
M	Black	Zip	F	Black	Zip
F	Blue	Zip	F	Black	Zip
F	Black	Zip	F	Black	Zip
M	Blue	Pullover	M	Blue	Pullover
F	Black	Zip	F	Black	Zip
F	Black	Zip	F	Black	Zip
M	Blue	Pullover	F	Black	Zip
F	Black	Zip	M	Blue	Pullover
F	Black	Zip	F	Black	Zip
M	Black	Pullover	M	Blue	Pullover
F	Black	Zip	F	Black	Zip
F	Blue	Zip	F	Blue	Pullover
M	Blue	Pullover	M	Black	Pullover
F	Black	Zip	M	Black	Zip
M	Black	Pullover	F	Black	Zip
F	Black	Zip	M	Black	Zip
F	Black	Zip	M	Blue	Pullover
M	Black	Pullover	F	Blue	Zip
M	Black	Zip	F	Black	Zip
F	Black	Zip	M	Black	Pullover
M	Black	Zip	F	Black	Zip
F	Blue	Pullover	F	Black	Zip
F	Black	Zip			

Teaching guidelines

In question 3 you can ask learners what the purpose of the totals in the bottom rows and right-hand side columns of the tables is.

Once learners have completed question 4, you can ask them to compare the results that were shown in the tables in question 1 and question 3. Ask them what kinds of hoodies the Student Council would have purchased had they used the results from the table in question 1, and how this differs from the hoodies they would have purchased based on the tables in question 3. You can also ask learners why the first table shows that black hoodies with zips are most popular, while the later tables show that male students mostly prefer pullover hoodies.

Possible misconceptions

Some learners may not fill in 0 in the tables where the count is zero. This is wrong. They tend to reason “nobody wants that”, rather than give the numerical answer to “how many want that?”

Answers

2. (a) Yes, 15 students want blue hoodies.
 (b) No. The tally table shows the number of female students, and the number of Grade 12s that like blue hoodies, but not the number of female students in Grade 12 that like blue hoodies.

3.

FEMALES	Black	Blue	Total
Zip	30	5	35
Pullover	0	2	2
Total	30	7	37

MALES	Black	Blue	Total
Zip	7	0	7
Pullover	7	8	15
Total	14	8	22

2. Think about the information in your tally table.
- (a) Can you answer this question from your tally table: “How many students want blue hoodies?”
- (b) Can you tell from the tally table how many female students want blue hoodies?
Why do you say this?

3. The Student Council wants you to analyse the data a bit deeper. They want to consider if it is worth ordering different styles and colours for the male and female students.

They ask you to fill in the tables below.

Copy the tables into your book, then tally and total the data into the tables.

Filling in the information in the tables will help you to organise the data. You will then be able to say, for example, how many female students want black hoodies with a zip and how many want blue pullover hoodies.

FEMALES	Black	Blue	Total
Zip			
Pullover			
Total			

MALES	Black	Blue	Total
Zip			
Pullover			
Total			

Answers

4. (a) The more popular of the two styles for females is the hoodie with a zip.
(b) Seven out of 22 males preferred hoodies with zips. That is about one third of the males. Pullovers were more popular with males (15 out of 22).
(c) Only 7 out of 37 females preferred blue hoodies. That is about one fifth of the females.
(d) Black was the more popular colour amongst male students. Fourteen out of 22 male students chose black hoodies. That is more than half of the males.
5. Reports will vary. The report should include the following information:

In total, there were 59 students who responded.

There were 37 females who responded.

Colour preference: By far the most females (30 out of 37) preferred black hoodies. Only seven females preferred blue hoodies. (Compare the totals at the bottom of the columns.)

Style preference: By far the most females liked hoodies with a zip (35 out of 37).

(Compare the totals on the right of the rows.)

Possible recommendation: If the Student Council wants to order one kind of hoodie for all the females it should be black hoodies with a zip (preferred by 30 females out of 37). (Compare the cell values.)

There were 22 males who responded.

Colour preference: By far the most males (14 out of 22) preferred black hoodies. Only eight males preferred blue hoodies. (Compare the totals at the bottom of the columns.)

Style preference: By far the most males liked pullover hoodies (15 out of 22). (Compare the totals on the right of the rows.)

Possible recommendation: If the Student Council wants to order one kind of hoodie for all the males it should be blue pullover hoodies (preferred by 8 males out of 22). (Compare the cell values.)

9.2 Collecting and organising numerical data

Mathematical notes

In the previous section learners saw that different representations can make different aspects of the data more visible. The focus on what is made more visible in different representations is continued in this section but the form of representation switches from tables to graphs.

4. Use the tally tables with data for female and male students to answer the questions.

- (a) Which style is more popular with female students: pullover or zip?

The most popular category is called the **modal category**.

We can ask the same question this way: Which style is the **modal** style?

- (b) How popular is the zip style among the male students?
(c) How popular is the colour blue among the female students?
(d) Which colour is more popular among male students?
We can also ask: Which is the **modal** colour for male students?

5. Write a report to the Student Council to earn your hoodie. Tell them about your findings. Give evidence from your tally tables.

9.2 Collecting and organising numerical data

Mrs Mholo is very unhappy about her electricity account this month. She pays her account every month and she is very careful to save electricity. Why is it so high this month?

This month, July, her account is R650. She believes that she used her usual amount of electricity. And there was lots of load shedding, so her account should be less than usual, not more than usual!

We will analyse Mrs Mholo's accounts over the past 12 months to see if there is a pattern in her use of electricity.

Here are Mrs Mholo's accounts, in rands, for the past 12 months, ordered by the months.

July last year						June this year					
Jul	Aug	Sept	Oct	Nov	Dec	Jan	Feb	Mar	Apr	May	Jun
486	403	405	412	412	416	412	424	462	495	500	529

In Term 1 we mentioned that graphs provide a picture of data. This picture facilitates the analysis of the data. We can also analyse data by examining how spread out or clustered it is and what a typical value is. In this section learners continue to use the concept of mode to examine the typical value or centre of the data. They also find the middle value of the set of data points – from Grade 6 onwards they will learn that this is called the median. Learners also look at the spread of data in this section.

Much of data handling involves reasoning in uncertain situations. This can make learners feel insecure, because there tends to be much greater certainty in other areas of Mathematics: there are usually one or more definite answers. In data handling learners need to use their analysis of the data as evidence to back up an argument. This is the case in question 1(e).

The months are categories in this data set. The amounts of the accounts are numerical data. The amounts are not frequencies; they are measurements of the amount of electricity Mrs Mholo has used, to which a monetary value has been attached.

Teaching guidelines

Prepare the table and graphs on the board or on a poster for use during class discussions.

Most of the questions in this section require interpretation: very few are simply facts. Learners need to use the data to motivate their answers. Allow sufficient time for learners to discuss their answers. Sometimes, for example in question 2(c), the class will be able to agree on an answer. Be aware however, that learners are likely to express their answers differently. There are questions, for example question 1(e), where learners may not be able to agree on an answer.

Answers

1. (a) R403 in August last year (b) R529 in June this year
- (c) July, March, April, May, June: all of these accounts were higher than R450.
- (d) Mrs Mholo can expect to use more electricity for heating in the winter months because it is colder. She can also expect to use more electricity for lighting in winter, as there are fewer daylight hours. Her accounts in winter differed by as much as R29. In summer she is likely to use less electricity for heating and lighting. Her accounts in summer did not differ by more than about R12.
- (e) Learners' answers may differ here. Some might say: "Yes, the account for June this year is R43 more than for July last year, and that is a big increase compared to the other increases."
Others might say: "No, she can expect to use more electricity in the winter months, and the increase between May and June this year is not even bigger than the increase between March and April this year."

We need more information to decide.

1. (a) What is the lowest account that Mrs Mholo got in the past 12 months?
- (b) What is the highest account that Mrs Mholo got in the past 12 months?
- (c) During which months did Mrs Mholo use the most electricity?
- (d) What differences between accounts can Mrs Mholo expect in the winter months? And in the summer months?
- (e) Do you think Mrs Mholo is right to be worried that her account is not correct?

If we make a graph of the data, the differences between the accounts are easy to see.

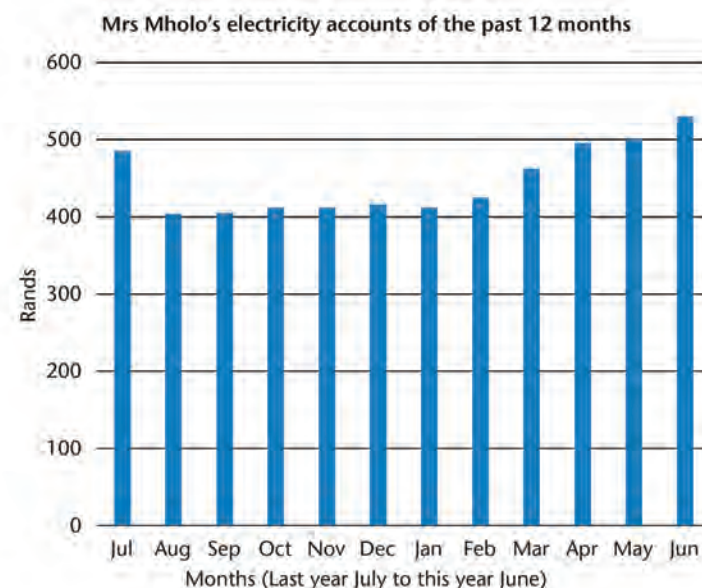

Critical knowledge

It is important that learners understand that when we analyse data we are looking for general trends. Sometimes a few data points may deviate from the overall pattern; we tend to overlook these points as we focus on the general impression. For example, in question 2(e) there has been a general increase in the amount of money that Mrs Mholo has paid since February. Learners should not be distracted by the fact that there was no increase between October and November and that what she paid in January was R4 less than what she paid in December. The overall trend is an increase. It is important that learners do not just look at the initial amount and the final amount, but at the pattern as a whole.

Answers

2. (a) No, because 10 out of the last 12 accounts were between R400 and R500.
(b) Yes, because none of the accounts of the past year have been less than R400.
(c) Not really. The last two accounts were R500 and more. Mrs Mholo thinks this is a mistake. However, her invoices have steadily increased from February this year.
(d) Yes, because none of the accounts of the past year have been more than R530.
(e) The overall trend in the bar graph shows an increase in the amount of money that Mrs Mholo paid for electricity since August last year. Since August last year her account has increased from R403 almost every month up to R529 in June this year.
3. (a) You don't see how much she paid in which month. You don't see whether the amounts only increased over time, only decreased over time, or increased for some months and decreased for other months.
(b) Answers will differ. Some learners may choose R412, which is the mode. Other learners may choose an amount in the middle. A suitable middle amount is R416, or R424, or even R420.
(c) R416 (The six highest accounts are all more than R416.)
(d) R486 (The three highest accounts are all more than R486.)

2. Work with the bar graph of the accounts and with the table to answer the questions.
- (a) Would you be surprised if Mrs Mholo gets an account that is between R400 and R500? Why do you say so?
(b) Would you be surprised if Mrs Mholo gets an account that is below R350? Why?
(c) Would you be surprised if Mrs Mholo gets an account that is more than R500? Why?
(d) Would you be surprised if Mrs Mholo gets an account that is more than R550? Why?
(e) Does the graph show that Mrs Mholo's use of electricity is increasing or decreasing, or about the same over the past 12 months? Say what you think.

We can organise the data in a different way. Many questions can be answered if we simply order numbers from small to large.

3. Here are Mrs Mholo's accounts for the past 12 months, ordered from small to large.

Mrs Mholo's accounts in rands, ordered from lowest to highest											
403	405	412	412	412	416	424	462	486	495	500	529

- (a) What information do we lose when we order the accounts from small to large?
(b) Which amount will you choose if you want to tell Mrs Mholo about how much her account usually is?
(c) Which amount will you choose if you want to tell Mrs Mholo: "Half your accounts are more than this amount"?
(d) Which amount will you choose to tell Mrs Mholo: "Only one quarter of your accounts were higher than this amount"?

The **mode** is the amount that occurs most frequently. Think critically: Does the mode tell the story of the graph or not?

Mathematical notes

Graphs give a picture of data. Different graphs give a different picture: they reveal different parts of the story.

The bar graph shown after question 1 allows you to see that Mrs Mholo uses more electricity in the winter months. From a very careful look at the bar graph you can see that Mrs Mholo paid less than R450 for about half of the months and more than about R450 for the other half of the months.

The pictograph shows clearly that the amounts she paid are spread between just over R400 and just under R500 and that half of the payments were less than R420.

Answers

4.

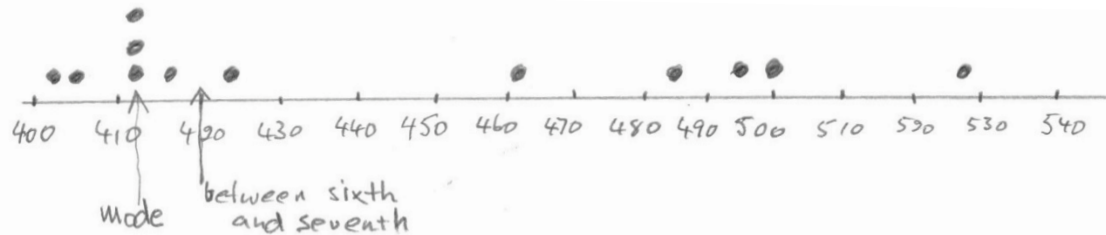

- (a) The mode is R412. This is where the most dots are. (See the first arrow above.)
 - (b) R420 is halfway between the sixth and the seventh value. (See the second arrow above.)
- 5.
- (a) True
 - (b) Not true, only five accounts are lower than R416. Correct the statement by saying: "lower or equal to R416".
 - (c) Not true, the lowest amount is R403, which is R9 lower.
 - (d) Not true. One account was R529. That is R117 higher.
 - (e) Not true. The accounts in winter are much higher.
 - (f) True
6. Mrs Mholo can show a pictograph (like the one above) and argue that in summer her accounts ranged between R403 and R420, and that while her accounts went up during the winter months, it was never by more than R30 a month. The big jump from R529 to R650 – more than R120 – from June to July is likely to be a mistake.

4. Use the list of accounts that are ordered from small to large in question 3. Use dots to draw a pictograph of the data on a number line like this one. The smallest amount (R403) and the biggest amount (R529) have been done for you. Place the dots as accurately as you can.

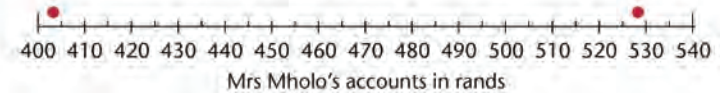

- (a) Look at your pictograph. Make a mark on the number line where you think the **mode** of all the amounts is. How did you decide?
 - (b) If you have not already done so, make a mark on the number line that is exactly halfway between the sixth and the seventh amount. Estimate the value at the mark you made.
5. Check if the following statements are true. Use the ordered accounts and the pictograph to check.
- (a) Half of Mrs Mholo's accounts in the previous 12 months were higher than R416, but lower than R529.
 - (b) Half of Mrs Mholo's accounts were also lower than R416, but not lower than R403.
 - (c) When Mrs Mholo's accounts were lower than R412, they were, at most, about R30 lower.
 - (d) When Mrs Mholo's accounts were more than R412, they were never more than R100 higher than R412.
 - (e) The mode of R412 is a good representation of all the accounts.
 - (f) The mode of R412 is a good representation of the accounts in summer.
6. Discuss with the class. If you were Mrs Mholo, how would you use the data to convince the municipality that an account of R650 must be a mistake? Write down your argument.

Learner Book Overview		
Sections in this unit	Content	Pages in Learner Book
10.1 More sequences	Diagonal sequences, i.e. patterns with an increasing difference	264
10.2 Patterns in tables	Families of sequences with a constant difference	265
10.3 Using patterns to solve problems	Equivalence between tables, rules and flow diagrams	266 to 268

CAPS time allocation	5 hours
CAPS page references	18 to 19 and 189 to 191

Continuing sequences or completing tables according to a pattern not only provides opportunities to develop understanding of patterns, but also contributes to the development of the **Mental Mathematics** section of the CAPS.

Mathematical background

Numeric patterns (number patterns), as part of the Content Area “Patterns, Functions and Algebra”, should serve as building blocks to develop the basic concepts of algebra in the Senior and FET phases. The study of numeric patterns should develop the concepts of **variable, relationships** and **functions**. The function concept is captured in the idea of applying a fixed rule to one set of numbers, to produce another set of numbers:

Input numbers → Rule → Output numbers

Much of our pattern work focuses on methods to find the calculation plan (**rule**), because a calculation plan is very useful to find missing **output numbers** and **input numbers**.

The following two important empowering approaches to pattern work should be emphasised throughout:

- **Recursive (“horizontal”) patterns** in sequences describing the relationship between any two consecutive numbers in a sequence, and then continuing the sequence, for example:

3 6 9 12 15 ...

- **Functional (“vertical”) patterns** describing the constant relationship between two sets of numbers, and then applying this pattern to calculate further-lying values (e.g. the 100th number), for example:

Position no. (Input): 1 2 3 4 5 100

Sequence no. (Output): 3 6 9 12 15 ...

These two ideas (**recursive** and **functional relationships**) are important for future mathematical concepts. Recursion leads to the important mathematical concepts of the gradient of a straight line and the derivative of a function. The function concept underlies all of high school algebra and calculus.

10.1 More sequences

Teaching guidelines

The focus of this section is the introduction of new kinds of sequences that are different to the constant differences patterns we have studied so far.

You should allow learners ample time to analyse the sequences, to describe the patterns in their own words, and to calculate numbers in the sequences.

As with the “families of sequences” in Term 1 Unit 4, learners should in question 2 *notice and use* the relationships between the sequences to make the work easier. For example, Sequence F, which consists of the square numbers, should be easy; the numbers in Sequence G are simply one more, and in Sequence H two more than the square numbers.

Answers

1. (a) $R4\ 800 \div 30 = R160$
 (b) $R4\ 800 \div 15 = R320$

(c)

Number of passengers	5	10	20	40	80	160
Cost for each passenger (R)	960	480	240	120	60	30

- (d) $Cost\ per\ passenger = Cost\ of\ hiring\ the\ bus \div number\ of\ passengers$
2. A (a) Start with 1 and then double each number to get the next number.
 (b) ..., 64, 128, 256, 512, 1 024
- B (a) Start with 512 and then halve each number to get the next number.
 (b) ..., 16, 8, 4, 2, 1
- C (a) Start with 3 and then double each number to get the next number.
 (b) ..., 192, 384, 768, 1 536, 3 072
- D (a) Start with 1 and then multiply each number by 3 to get the next number.
 (b) ..., 243, 729, 2 187, 6 561, 19 683
- E (a) Start with 2 and then multiply each number by 3 to get the next number.
 (b) ..., 486, 1 458, 4 374, 13 122, 39 366
- F (a) Square numbers, i.e. numbers multiplied by itself: $1 \times 1, 2 \times 2, 3 \times 3, \dots$
 (b) ..., 49, 64, 81, 100, 121
- G (a) Start with 2, then +3, +5, +7, ... or: The numbers are 1 more than in Sequence F.
 (b) ..., 50, 65, 82, 101, 122
- H (a) Start with 3, then +3, +5, +7, ... or: The numbers are 1 more than in Sequence G.
 (b) ..., 51, 66, 83, 102, 123

UNIT 10

NUMERIC PATTERNS

10.1 More sequences

1. The cost of hiring a mega bus to travel from Johannesburg to Polokwane and back is R4 800.
- (a) If 30 people go on the trip, how much must each passenger pay if they share the cost equally?
- (b) If 15 people go on the trip, how much must each passenger pay if they share the cost equally?

- (c) Complete the table:

Number of passengers	5	10	20	40	80	160
Cost for each passenger (R)						

- (d) Write a calculation plan to show how to calculate the cost for each passenger for *any* number of passengers travelling on the bus.
2. For each of Sequences A to H:
- (a) Describe the patterns in your own words.
- (b) Continue the pattern for five more numbers.
- Sequence A: 1, 2, 4, 8, 16, 32, ...
- Sequence B: 512, 256, 128, 64, 32, ...
- Sequence C: 3, 6, 12, 24, 48, 96, ...
- Sequence D: 1, 3, 9, 27, 81, ...
- Sequence E: 2, 6, 18, 54, 162, ...
- Sequence F: 1, 4, 9, 16, 25, 36, ...
- Sequence G: 2, 5, 10, 17, 26, 37, ...
- Sequence H: 3, 6, 11, 18, 27, 38, ...

10.2 Patterns in tables

Teaching guidelines

These activities are very dependent on your discussing with learners appropriate thinking to analyse the given information, and to make sure they adequately engage with the problems so that they can *reason* about the situations.

For example, the task in question 1 is not to complete the table for the sake of completing the table, but for learners to *interpret* the information they generate in the table in order to answer the question: Which company is cheaper?

Notes on questions

Question 1 requires that learners will analyse the relationship between the two cost sequences by comparing the corresponding values. They will find that for 200 km the cost is the same, for less than 200 km AfriCars is cheaper and for more than 200 km Image Car Rental is cheaper.

To find the cost in the table for travelling a certain distance, learners must implement the formulation in words as a calculation rule for each company:

$$\text{Cost for Image Car Rental} = 2 \times \text{Distance travelled} + 180$$

$$\text{Cost for AfriCars} = 2,50 \times \text{Distance travelled} + 80$$

Question 2 is an example of a *decreasing* sequence, where we *subtract* to find the next number.

Learners can solve the problem by continuing the sequence 60, 56, 52, ... until they reach zero (the tank is empty). However, this will be cumbersome. It is important that learners realise this and understand that they should try to find a shorter, more efficient method. It will be better to reason it out:

From the table you can see that the car uses 4 ℓ of petrol to drive 40 km.

So with 1 ℓ it drives 10 km, so with 60 ℓ (a full tank) it drives $60 \times 10 \text{ km} = 600 \text{ km}$.

Answers

1. (a)	Distance (km)	0	50	100	150	200	250	300
	Cost: Image (R)	180	280	380	480	580	680	780
	Cost: AfriCars (R)	80	205	330	455	580	705	830

(b) It depends on the distance he wants to travel. For less than 200 km AfriCars is cheaper. For 200 km they cost the same. For more than 200 km Image Car Rental is cheaper.

2. 600 km

10.2 Patterns in tables



- Avril wants to rent a car for one day. He wonders if he should rent from Image Car Rental or from AfriCars.

Both charge a *basic amount per day* plus a *rate per kilometre* for the distance driven, according to the values in the table. Avril now wonders which company is cheaper.

Company	Car	Per day	Per kilometre
Image	4-door sedan	R180	R2
AfriCars	4-door sedan	R80	R2,50

- Help Avril to decide which company is cheaper by completing the table of costs for AfriCars and for Image Car Rental, for travelling different distances with the hired car.

Distance (km)	0	50	100	150	200	250	300
Cost: Image (R)							
Cost: AfriCars (R)							

- What is your advice to Avril: should he hire from AfriCars or from Image Car Rental?
- Xolile fills up his car's tank with petrol. When full, the tank holds 60 ℓ of petrol. The table below shows how much petrol is left in the tank as Xolile drives.

Distance driven (km)	0	40	80	120	160
Petrol in tank (ℓ)	60	56	52	48	44

Based on this information, how many kilometres can Xolile expect to drive until the petrol tank is completely empty?

10.3 Using patterns to solve problems

Notes on questions

Learners have met the party tables before in the unit on geometric patterns in Term 2.

To calculate the number of people for a large number of tables will be cumbersome if we use the horizontal +2 pattern. It will be more useful to find a calculation plan. We again outline the thinking required to see the structure in the picture (from page 179 of the Learner Book) that enables us to formulate a calculation plan.

The way to “see” structure is to understand that in Figure 4 we try to see a unit of 4, in Figure 3 a unit of 3 in the same way, in Figure 2 a unit of 2, etc. as illustrated below:

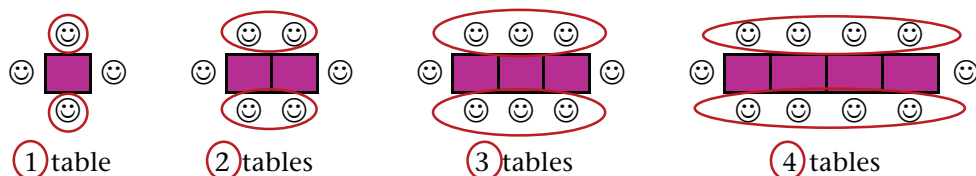

The challenge is then to generalise the structure so that we can easily calculate how many people will sit at 45 small tables:

$$T1 = 2 \times 1 + 2$$

$$T2 = 2 \times 2 + 2$$

$$T3 = 2 \times 3 + 2$$

$$T4 = 2 \times 4 + 2$$

⋮

$$\text{So } T45 = 2 \times 45 + 2$$

$$\text{No. of people} = (2 \times \text{No. of tables}) + 2$$

Answers

1. (a)	No. of tables	1	2	3	4	5	6	7	15	20	45
	No. of people	4	6	8	10	12	14	16	32	42	92

(b) Learners' answers may differ.

(c) Learners discuss their patterns.

2. (a) A $-\boxed{\times 2}-\boxed{+ 2}\rightarrow$

B $-\boxed{+ 1}-\boxed{\times 2}\rightarrow$

(b) Both flow diagrams are correct.

10.3 Using patterns to solve problems

For his party, Anand arranges small square tables in a straight line, so that one person sits at each side of the table. For example, if there are 4 tables, then 10 people can sit at the tables, as shown:



1. (a) Complete this table to show how the number of people changes as the number of tables changes.

No. of tables	1	2	3	4	5	6	7	15	20	45
No. of people	4			10						

(b) Describe your method.

(c) What patterns do you see in the table? Discuss!

2. To calculate the number of people that can sit at the tables, Anand wants to use Flow diagram A below or Flow diagram B on the next page.

(a) Help Anand by completing the operators.

(b) Which flow diagram should Anand use?

Flow diagram A

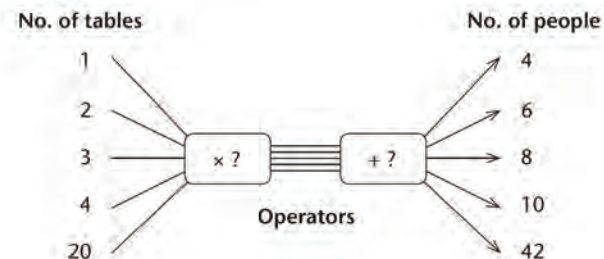

Notes on questions

Questions 2 and 3 focus on two equivalent descriptions for the number of tables, represented in the form of flow diagrams, tables and calculation plans.

We illustrate below how to “see” a different structure from that in question 1:

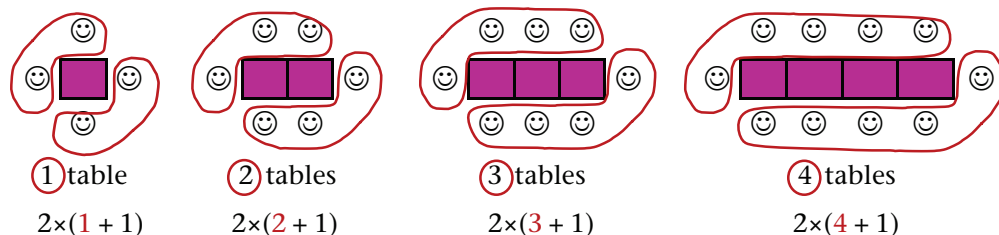

The challenge is then to generalise the structure so that we can easily calculate how many people will sit at 45 small tables:

$$T_1 = 2 \times (1 + 1)$$

$$T_2 = 2 \times (2 + 1)$$

$$T_3 = 2 \times (3 + 1)$$

$$T_4 = 2 \times (4 + 1)$$

⋮

$$\text{So } T_{45} = 2 \times (45 + 1)$$

$$\text{No. of people} = 2 \times (\text{No. of tables} + 1)$$

You should emphasise that **equivalent calculation plans** are *different* methods that give the *same* answers. We can see it in the pictures, in the flow diagrams and in the tables. We should also see it in the numerical expressions. For example, we can write the number sentence:

$$2 \times (45 + 1) = 2 \times 45 + 2$$

We can show that both calculation plans give the same answer (92), but we should also know that these two calculation plans are equivalent because of the distributive property of multiplication over addition.

Answers

3.	No. of tables	1	2	3	4	5	6	7	15	20	45
	$2 \times \text{No. of tables} + 2$	4	6	8	10	12	14	16	32	42	92
	$2 \times (\text{No. of tables} + 1)$	4	6	8	10	12	14	16	32	42	92

They are both correct.

Flow diagram B

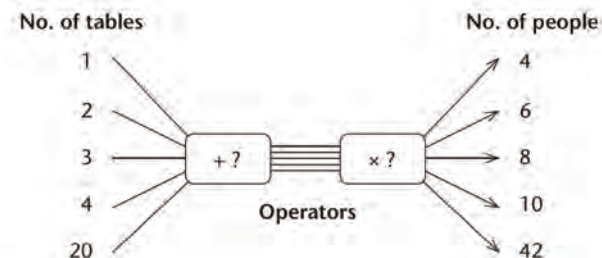

If flow diagrams with different operators give the same output numbers for the same input numbers, they are **equivalent**. So we can choose which one to use.

3. Anand’s friend Jake is helping him to plan the party.

Anand says that to calculate the number of people that can sit at the tables they must use this calculation plan (rule):

$$\text{Number of people} = 2 \times \text{Number of tables} + 2$$

Jake says they should use this plan:

$$\text{Number of people} = 2 \times (\text{Number of tables} + 1)$$

Who is correct, Anand or Jake?

Complete this table using the two plans to see who is correct.

No. of tables	1	2	3	4	5	6	7	15	20	45
$2 \times \text{No. of tables} + 2$										
$2 \times (\text{No. of tables} + 1)$										

Mathematical notes

Writing the inverse of a flow diagram is very important because it provides the most efficient method to find unknown input numbers, i.e. to solve equations.

Inverting a flow diagram involves inverse operations in reverse order, for example:

Flow diagram: $? \xrightarrow{\boxed{\times 2}} \boxed{+ 2} \rightarrow 48$

Inverse flow diagram: $23 \xleftarrow{\boxed{\div 2}} \boxed{- 2} \leftarrow 48$

This describes exactly the procedure to formally solve the equation $2x + 2 = 48$:

$$2x + 2 = 48$$

$$x = (48 - 2) \div 2$$

This is exactly what the first inverse flow diagram in question 4 shows.

The second inverse flow diagram shows the solution of the equation $2(x + 1) = 48$:

$$x = 48 \div 2 - 1$$

Teaching guidelines

Do not let learners rewrite the flow diagrams. Question 4(a) only asks them to specify the operators for the inverse flow diagrams.

Answers

4. (a) $\boxed{- 2} \boxed{\div 2} \rightarrow$ and
 $\boxed{\div 2} \boxed{- 1} \rightarrow$

(b) $48 \xrightarrow{\boxed{- 2}} \boxed{\div 2} \rightarrow 23$ or
 $48 \xrightarrow{\boxed{\div 2}} \boxed{- 1} \rightarrow 23$

In questions 2 and 3 Anand calculated the number of people as output number. It will be easier to have a flow diagram with the known number of people as input number to calculate the unknown number of tables needed.

4. Below are the two flow diagrams that you used in question 2.

(a) Change the operators so that the number of people is the input number.

(b) Then calculate the number of tables needed if Anand knows there will be 48 people at the party (including himself),

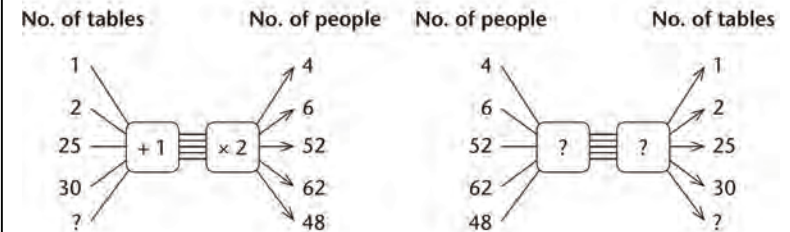
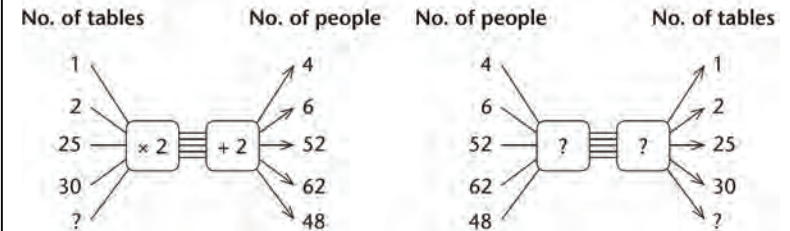

Learner Book Overview		
Sections in this unit	Content	Pages in Learner Book
11.1 Count, add, multiply and divide	Mental Mathematics	269 to 273
11.2 Factors and multiples	The terms “factor”, “product” and “multiple”, and factorisation	274 to 276
11.3 Use factors to multiply	Multiplication by factorising one of the numbers	276 to 277
11.4 Multiplication practice	Practising multiplication of 2-digit numbers by 3-digit numbers	277
11.5 Multiplication in real life	Solving word problems	277 to 278
11.6 More calculations in real life	Solving word problems	278 to 279

CAPS time allocation	7 hours
CAPS page references	13 to 15 and 192 to 193

Mathematical background

The key to effective multiplication of whole-digit numbers is to replace the given product, for example 42×54 , with a number of smaller products for which the answers are known (remembered) or can be found easily.

Because multiplication distributes over addition, 42×54 can be replaced with $42 \times 50 + 42 \times 4$, and this can be replaced with $40 \times 50 + 2 \times 50 + 40 \times 4 + 2 \times 4$.

A person who knows the facts $4 \times 5 = 20$, $2 \times 5 = 10$, $4 \times 4 = 16$ and $2 \times 4 = 8$ can with some skill easily form the facts $40 \times 50 = 2\,000$, $2 \times 50 = 100$, $40 \times 4 = 160$ and $2 \times 4 = 8$ that are required to execute the calculation plan $40 \times 50 + 2 \times 50 + 40 \times 4 + 2 \times 4$:
 $2\,000 + 100 + 160 + 8 = 2\,268$.

In the above calculation, the factors 42 and 54 of the original product 42×54 were broken down into the sums $40 + 2$ and $50 + 4$, and the *product of sums* $(40 + 2) \times (50 + 4)$ was then replaced by the *sum of products* $(40 \times 50) + (2 \times 50) + (40 \times 4) + (2 \times 4)$.

Alternatively, one of the numbers of the original product can be factorised, while the other number is written as a sum, as in the above. For example:
 $42 \times 54 = 2 \times 3 \times 7 \times (50 + 4)$.

The calculation can then proceed as shown on the right.

$$\begin{aligned}
 & 2 \times 3 \times 7 \times (50 + 4) \\
 = & 2 \times 3 \times 378 \quad \text{because } 7 \times 50 + 7 \times 4 = 378 \\
 = & 2 \times 1\,134 \quad \text{because } 3 \times 300 + 3 \times 70 + 3 \times 8 = 1\,134 \\
 = & 2\,268
 \end{aligned}$$

11.1 Count, add, multiply and divide

Teaching guidelines

The extent to which learners spontaneously utilise the mathematics they have learnt is an important indication of the quality of their mathematical knowledge.

In this respect it may be quite informative to begin the work in this section by starting with question 3, i.e. asking learners to find out how many bananas are shown in Picture B on page 272 of the Learner Book. Let them describe how they did it on a loose sheet of paper that you take in to analyse. Here are some of the ways in which learners may do it:

- Counting the bananas one by one
- Counting the bananas in eights: $8 \ 16 \ 24 \ 32 \ \dots \ 560$
- Counting the bunches and calculating: 70×8
- Counting or calculating the number of bananas in one row and multiplying this by 10, for example 56×10 or $7 \times 8 \times 10$. Alternatively, learners may work with the columns, for example 7 columns of 80 bananas each.

Learners who use the first or second strategy mentioned above clearly do not have a strong sense of how multiplication relates to real situations. Such learners may benefit substantially from the work in this section.

Mathematical notes

This section provides learners with opportunities to deepen their understanding of the meaning of multiplication as repeated addition and counting in groups. At the same time the questions provide concrete experiences of numbers as the products of several factors.

Notes on questions

Question 1 is intended to guide learners towards observing the structure of the three pictures of bunches of bananas.

Answers

- (a) Learners write down their plans for finding the answer.
(b) Learners write down their plans for a quicker way to find the answer.
- (a) Learners write down their plans to find the answer.
(b) Learners write down their plans for a quicker way to find the answer.
- (a) 560 bananas
(b) Learners' answers may differ.

UNIT

11

WHOLE NUMBERS:

MULTIPLICATION

11.1 Count, add, multiply and divide

On pages 271 to 273 you will see pictures of many bananas. Have a look at them. Then turn back to this page.

1. Read the question below.

How many more bananas are shown in Picture C than in Picture B?

- (a) Look again at Picture C and at Picture B. Think of a way in which you can find the answer to this question. Then describe your plan in writing. Do not work out the answer; just describe your plan.
- (b) See if you can think of a quicker way to find the answer. If you can, describe your plan in writing but do not work out the answer.

2. Now read this question:

How many bananas are shown in Picture A?

- (a) Look at Picture A and think of a way in which you can find the answer to the question. Describe your plan in writing but do not work out the answer.
- (b) Can you think of a quicker way than the one you have just described? If you can, describe it in writing but do not work out the answer.

3. (a) How many bananas are shown in Picture B? Work out the answer.
(b) Describe what you did to find the answer.

Nare wanted to find out how many bananas there are in Picture C. He first thought of counting the bananas one by one and started like this: 1, 2, 3, 4, 5, 6, 7, 8, 9, 10, 11, 12, ...

He then realised this would take a very long time.

Teaching guidelines

When learners have completed questions 1 to 3, you may explain various strategies as described in the tinted passage on pages 269 to 270 of the Learner Book, with reference to Picture C on page 273.

It is important that learners try to do question 6 without drawing a picture. Questions 6 and 7 are intended to lift learners' engagement to a higher level of abstraction.

Note that questions 9 and 10 require division. Question 9 requires learners to determine the size of each share if 640 is divided into 80 equal shares. Question 10 is a grouping question: it requires learners to determine how many groups there are if 720 is divided into groups (bunches) of 6 each.

Answers

4. 630 bananas
5. 140 bananas
6. 400 bananas
7. (a) 480 bananas (b) 480 bananas (c) 480 bananas
8. Learners' own descriptions
9. 8 bananas
10. 120 bunches

Then he thought of counting in nines and started like this:
9, 18, 27, 36, 45, 54, ...

Nare realised that counting in nines would also take quite long, and he was worried that he might make mistakes. So he decided to count how many bunches there are, and he wrote it like this:

1	2	3	4	5	6	7
8	9	10	11	12	13	14
15	16	17	18		

But Nare did not continue. He decided to just count how many rows there are.

What do you think of Nare's plan?

Now answer these questions:

4. How many bananas are shown in Picture C?
5. How many more bananas are shown in Picture B than in Picture A?
6. There is another picture of bananas. It is called Picture D but it is not shown in this book. It shows bananas in bunches of 5.
There are 8 bunches in each row, and 10 rows in total. How many bananas are shown in Picture D?
7. In each case below, find out how many bananas there are in total.
 - (a) There are 6 rows with 8 bunches of bananas in each row.
There are 10 bananas in each bunch.
 - (b) There are 10 rows with 6 bunches of bananas in each row.
There are 8 bananas in each bunch.
 - (c) There are 8 rows with 10 bunches of bananas in each row.
There are 6 bananas in each bunch.
8. Describe how you found your answers to questions 7(b) and (c).
9. There are 80 bunches of bananas in a crate. The number of bananas in each bunch is the same. There are 640 bananas in total in the crate. How many bananas are there in each bunch?
10. There are 720 bananas in bunches of 6 bananas each in a crate. How many bunches are there in the crate?

Additional material

You may use copies of the diagrams below for additional activities of the same kind.

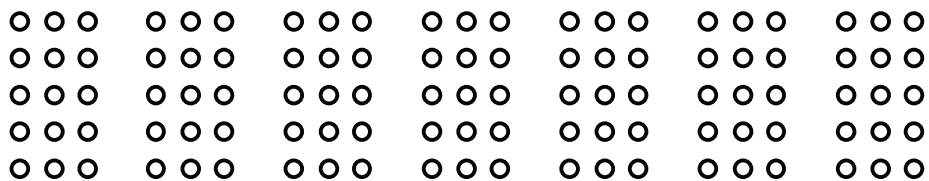
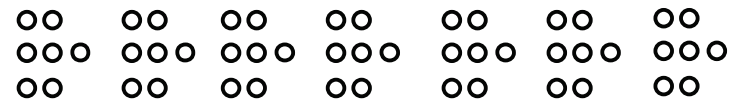
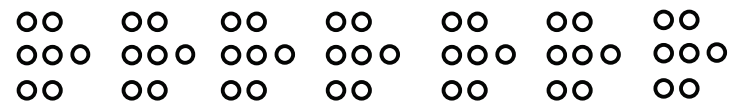
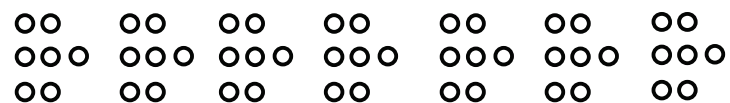
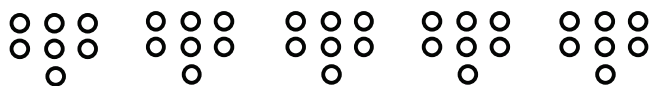
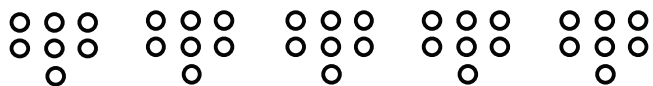
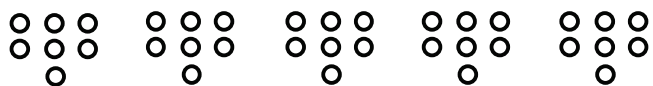

Picture A

GRADE 5: MATHEMATICS [TERM 3] 271

Mathematical notes

Multiplication is applicable to a wide variety of different kinds of situations, including those described below:

- Repetition of the same amount/number, for example in the question: “How many apples are there in 23 boxes with 72 apples each?”
- A rectangular array, for example Picture B on the right
- A total based on a rate, for example the cost of 58 ℓ of petrol at R12 per litre
- A ratio (scale) situation, for example when a house is 50 times as big as the building plan.

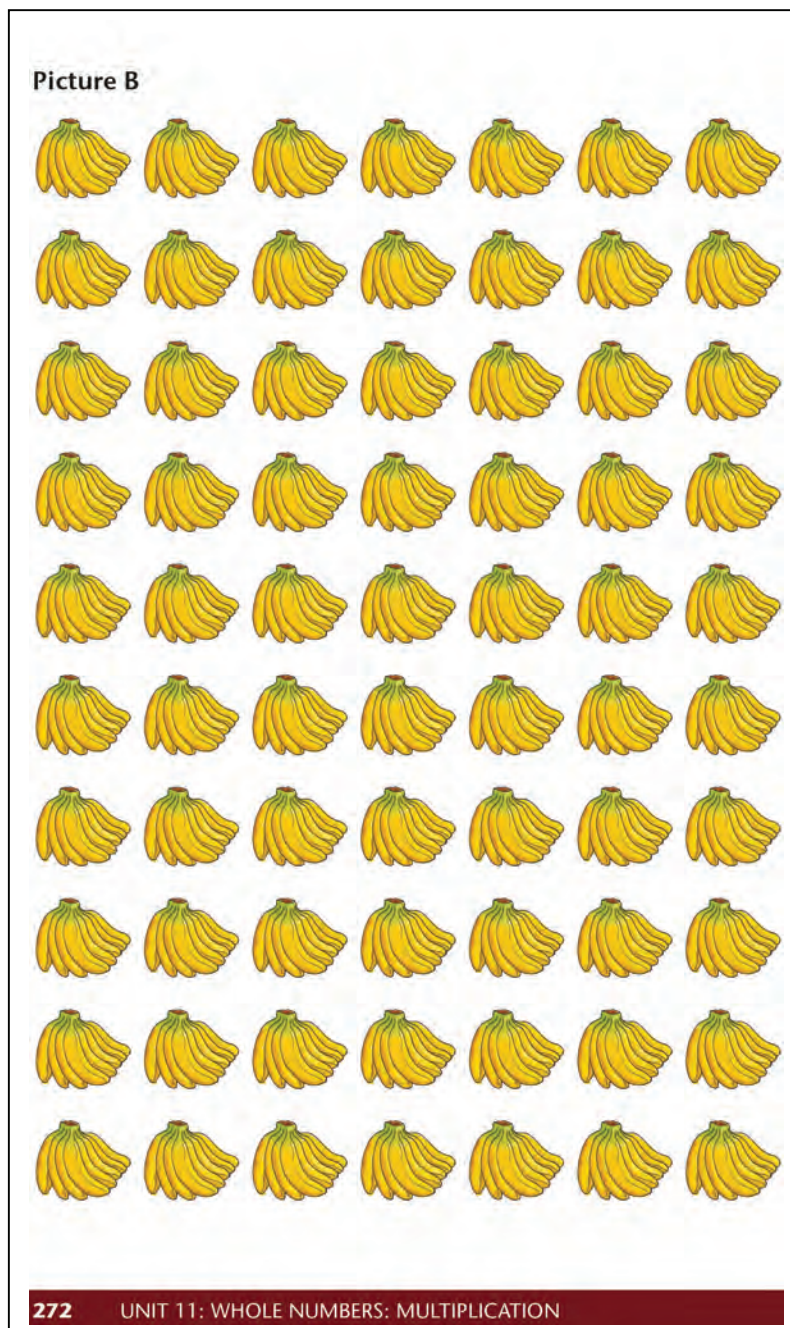

Picture C

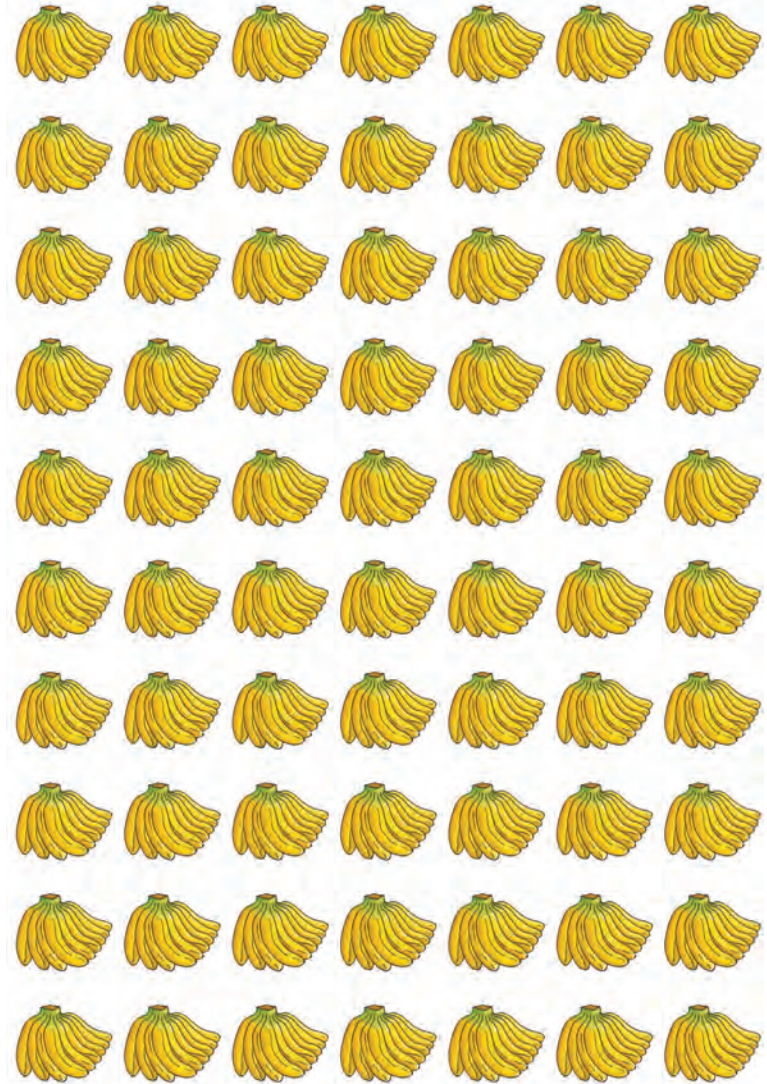

11.2 Factors and multiples

Teaching guidelines

Ask learners to do question 1 and to write down, for each colour, how they calculated the total. Take feedback when learners have finished and write some of the learners' calculation plans on the board. Some of the plans that learners may have used are:

$$4 \times 3 \times 5 \qquad 6 \times 2 \times 5 \qquad 3 \times 4 \times 5$$

Let learners then do question 2. Ask them to comment on the connection between questions 1 and 2.

Answers

- Blue: 60; red: 60; yellow: 60
- $2 \times 3 \times 10$; $2 \times 5 \times 6$
- (a) For example: $3 \times 4 \times 10$; $2 \times 5 \times 12$
(b) For example: $2 \times 3 \times 4 \times 5$; $2 \times 2 \times 5 \times 6$
(c) For example: $1 \times 2 \times 3 \times 4 \times 5$; $2 \times 2 \times 2 \times 3 \times 5$
(d) 1; 2; 3; 4; 5; 6; 8; 10; 12; 15; 20; 24; 30; 40; 60; 120
- (a) 1 row of 30 plants; 2 rows of 15 plants; 3 rows of 10 plants
(b) 1×30 ; 2×15 ; 3×10 ; 5×6
- (a) 1 row of 24 plants 2 rows of 12 plants
3 rows of 8 plants 4 rows of 6 plants
6 rows of 4 plants 8 rows of 3 plants
12 rows of 2 plants 24 rows of 1 plant
(b) 1; 2; 3; 4; 6; 8; 12; 24 (c) 1×24 ; 2×12 ; 3×8 ; 4×6
(d) $2 \times 3 \times 4$ (e) $2 \times 2 \times 2 \times 3$

Additional questions

Question 3 may be extended by asking learners to find *all* the different ways in which 120 (or some other numbers) can be expressed as a product of two factors, a product of three factors, and so on. You may also ask learners whether 120 can be expressed as a product of six factors that do not include 1.

11.2 Factors and multiples

- How many beads of each colour are shown below?

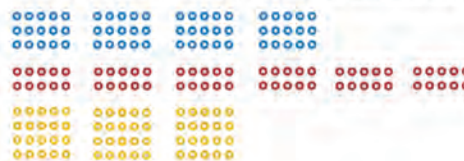

- The number 60 can be produced by calculating $4 \times 3 \times 5$. Write 60 by multiplying three other numbers.

We call $4 \times 3 \times 5$ a **product** and 4, 3 and 5 are the **factors** of this product.

- (a) Write 120 as the product of 3 factors in two different ways.
(b) Write 120 as the product of 4 factors.
(c) Write 120 as the product of 5 factors.
(d) Make a list of all the factors of 120.
- Grandpa likes to plant his bean plants in neat patches that look like rectangles. He planted his 30 bean plants in a patch with 5 rows and 6 plants in every row.
(a) Is there another way in which Grandpa can arrange his 30 plants?
(b) Write 30 as a product of two numbers in three different ways.
- (a) How can Grandpa arrange 24 tomato plants in neat rectangular patches? Describe all the different ways.
(b) Write down all the factors of 24.
(c) Write 24 as a product of two factors in more than one way.
(d) Write 24 as a product of three factors.
(e) Write 24 as a product of four factors.

Teaching guidelines

The method described in the tinted passage involves considering each of the numbers 1, 2, 3, 4, 5, etc. as a possible factor of 24. If a number is a factor of 24, its “partner” is also written down. The method is demonstrated below for finding the factors of 20, using number sentences as an alternative and more complete way of recording the same thinking.

Consider all whole numbers up to half of the “target” number as possible factors:

$$\begin{array}{cccccc}
 1 \times \dots = 20 & 2 \times \dots = 20 & 3 \times \dots = 20 & 4 \times \dots = 20 & 5 \times \dots = 20 & \\
 6 \times \dots = 20 & 7 \times \dots = 20 & 8 \times \dots = 20 & 9 \times \dots = 20 & 10 \times \dots = 20 &
 \end{array}$$

Solve the number sentences with numbers that are factors of 20 and cross out the others:

$$\begin{array}{cccccc}
 1 \times 20 = 20 & 2 \times 10 = 20 & \del{3 \times \dots = 20} & 4 \times 5 = 20 & 5 \times 4 = 20 & \\
 \del{6 \times \dots = 20} & \del{7 \times \dots = 20} & \del{8 \times \dots = 20} & \del{9 \times \dots = 20} & 10 \times 2 = 20 &
 \end{array}$$

Answers

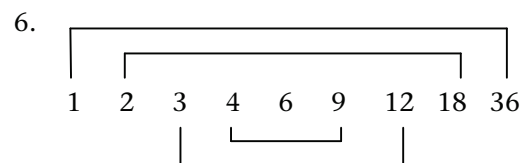

The factor 6 does not have a partner because 6 is multiplied by itself to give 36.

7. 1 row of 36 plants 2 rows of 18 plants 3 rows of 12 plants
4 rows of 9 plants 6 rows of 6 plants 9 rows of 4 plants
12 rows of 3 plants 18 rows of 2 plants 36 rows of 1 plant
8. Yes
9. The answer is the same as the number you multiplied 1 by.
10. When a number is multiplied by 1, the value of that number does not change.

Mamele uses a trick to make sure that she knows all of the factors of a specific number. This is how she writes the factors of 24:

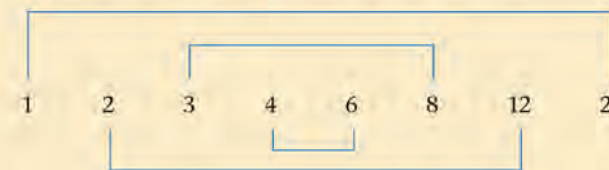

She links every factor, starting with 1, with the other number with which the product 24 will be formed: 1×24 ; 2×12 ; 3×8 ; 4×6 .

So 1, 2, 3, 4, 6, 8, 12 and 24 are all factors of 24.

Every one of 24's factors has a partner. The product of the two partners is the 24.

6. Use Mamele's trick and write down all the factors of 36. What do you notice?
7. Grandpa has 36 eggplants. How can he arrange them into neat rectangular patches?

All the numbers that can divide into a number without leaving a remainder are called the **factors** of that number. Two or more of the factors can be multiplied to form that number.

In questions 5(c), (d) and (e) you had to break up 24 into factors.

8. Siba says 1 is a factor of every number. Is this true?
9. What happens if you multiply 1 by any number?
10. The number 1 has a special property when it is multiplied. Write this property in your own words.

When the number 1 is multiplied by any number, the value of that number does not change.

Answers

11. (a) 20; 25; 30; 35; 40
(b) 48; 60; 72; 84; 96
(c) 36; 45; 54; 63; 72
12. 15; 30; 45; 60; 75
13. Yes; 12 is a multiple of 6 and because 6 is a factor of 12, 6 will divide into any multiple of 12 without a remainder.
14. (a) Yes, $1\ 001 \div 13 = 77$
(b) You can write down all the multiples of 13 up to just over 1 000, but that is a tedious method. Rather use repeated subtraction in a clever way:

$$\begin{array}{r} 13 \times 100 \rightarrow 1\ 300 \\ \text{halve } 1\ 300 \rightarrow 650 = 13 \times \underline{50} \\ 1\ 001 - 650 = 351 \qquad \qquad \qquad 50 \\ 13 \times 10 \rightarrow 130 \qquad \qquad \qquad 20 \\ \text{double } 130 \rightarrow 260 = 13 \times \underline{20} \qquad \qquad \qquad 5 \\ 351 - 260 = 91 \qquad \qquad \qquad \underline{+2} \\ \text{halve } 130 \rightarrow 65 = 13 \times \underline{5} \qquad \qquad \qquad 77 \\ 91 - 65 = 26 = 13 \times \underline{2} \end{array}$$

11.3 Use factors to multiply

Teaching guidelines

Demonstrate on the board that if one of the two numbers in a product can be factorised into 1-digit factors, this provides an easy alternative way to evaluate a product.

$$\begin{aligned} \text{Example: } 150 \times 72 &= 3 \times 5 \times 10 \times 72 = 3 \times 72 \times 5 \times 10 \\ &= 216 \times 5 \times 10 \\ &= 1\ 080 \times 10 \\ &= 10\ 800 \end{aligned}$$

Answers

1. (a) 1 820 (b) 1 820 (c) 1 820
(d) Learners' opinions may differ.
2. (a) For example: $2 \times 5 \times 3 \times 17$ (b) For example: $3 \times 7 \times 53 \times 2$

11. Write the next five numbers in each pattern:

- (a) 5; 10; 15; ...
(b) 12; 24; 36; ...
(c) 9; 18; 27; ...

All the numbers in question 11(a) are multiples of 5. The numbers in (b) are multiples of 12 and those in (c) are multiples of 9.

12. Write down the first 5 multiples of 15.
13. Sami says that every multiple of 12 is also a multiple of 6. Is that true? Try to explain this in your own words.
14. (a) Is 1 001 a multiple of 13?
(b) What did you do to find out whether 1 001 is a multiple of 13?

A number can divide into any of its multiples without leaving a remainder.

11.3 Use factors to multiply

1. Calculate.
- (a) 35×52
(b) $5 \times 52 \times 7$ (work from left to right)
(c) $7 \times 52 \times 5$
(d) Which calculation was the easiest?
2. Rearrange the factors in the products to make it easier to multiply.
- (a) $2 \times 17 \times 5 \times 3$
(b) $53 \times 2 \times 7 \times 3$

Norma knows that it is easy to multiply by small numbers such as 2, 3 or 5. When she has to multiply larger numbers, she breaks up one of the numbers into factors. Then she rearranges the factors to make the multiplication easier.

Answers

3. Learners break up one of the numbers when calculating.
The answers are:
- (a) 2 226 (b) 6 336
(c) 24 255 (d) 15 972

11.4 Multiplication practice

Answers

1. (a) 3 445 (b) 3 710
(c) 8 432 (d) 8 432
(e) 16 864 (f) 9 102
2. (a) 8 328 (b) 14 754
(c) 21 306 (d) 10 854
(e) 11 407 (f) 10 736

11.5 Multiplication in real life

Answers

- 29 638 learners
- 1 456 km
- R3 672
- 5 916 television sets
- 1 311 oranges

3. Do the following multiplications by breaking up one of the numbers into factors.
- (a) 42×53 (b) 48×132
(c) 105×231 (d) 242×66

11.4 Multiplication practice

Calculate.

1. (a) 265×13 (b) 14×265
(c) 248×34 (d) 68×124
(e) 248×68 (f) 246×37
2. (a) 347×24 (b) 42×347
(c) 402×53 (d) 54×201
(e) 671×17 (f) 16×671

11.5 Multiplication in real life

- A local bus can carry 73 learners to school every day. This bus does 406 trips every year. How many learners can it carry on this route in one year?
- It takes Fred 13 hours to drive to his parents' farm. If he travels approximately 112 km every hour, how far does he travel?
- Steve needs 24 m of fencing to make a camp for his goats. The fencing material that he uses costs R153 per metre. How much will the fencing material cost him?
- A hotel group has 17 lodges throughout the country. Each lodge has 348 rooms. The managers of the hotel group want to put a new television set in each room. How many television sets do they have to order?
- A farm stall owner sells oranges. He puts 23 oranges in a pocket. If he fills exactly 57 pockets, how many oranges did he buy from the orange farmer?

Notes on questions

Question 6 is specifically designed to challenge learners to read the problem statement carefully, and not to indiscriminately decide to do a certain operation on certain numbers.

Question 9 is demanding. It helps to work out the number of tins: 6 dozen is $6 \times 12 = 72$.

One way to work out the total cost is to think of 72 as four groups of 18 tins: you only have to pay for three of the groups, so the cost is $3 \times 18 \times R6,15$.

Another way to work out the total cost is to argue that you will pay $3 \times R6,15 = R18,45$ for every 4 tins (because when you buy 4 tins you only pay for 3 tins at R6,15 each). One dozen is 3 groups of 4 tins, so 6 dozen is $6 \times 3 = 18$ groups of 4 tins. So the total cost is $18 \times R18,45$.

Note that question 10 asks for estimates only. Three pods will be about 126 beans, which is close to what is needed for 1 kg of chocolate. So 14 kg of chocolate requires about $14 \times 3 = 42$ cacao pods.

Answers

6. (a) $(20 + 8) \times 12 \times 30$ (b) 10 080 eggs
7. R29 376 8. 5 880 trays
9. R332,10 10. About 42 cacao pods

11.6 More calculations in real life

Teaching guidelines

Warn learners that the questions in this section are tricky and require careful reading. Many of the questions require more than one step.

Notes on questions

Question 1:

Shop B has $18 \times 53 = 954$ glass jars. The two shops together have $954 + 53 = 1\,007$ glass jars.

Question 3: You may have to help learners to understand the context.

There are $62 \times 28 = 1\,736$ seats in total. Hence $1\,736 - 690 = 1\,046$ tickets were sold before Saturday night.

Answers

1. 1 007 glass jars
2. R2
3. 1 046 tickets

6. (a) Farmer Tavuk forgot to record how many eggs he sent to the supermarket, but he remembers that 28 crates were loaded into the truck. Each of the 28 crates contained 12 trays, and each tray had 30 eggs.

Which of the following calculations will help Farmer Tavuk to record the correct number of eggs?

$(28 + 12) \times 30$ $(28 \times 30) + 12$
 $(20 + 8) \times 12 \times 30$ $(12 \times 30) + 28$

- (b) How many eggs did he send to the supermarket?
7. The Trano Café sold 432 lunches on Saturday at R68 each. How much money did the café make on Saturday?
8. A nursery has a contract to deliver 168 trays of herb seedlings to a garden centre every week. How many trays will the nursery deliver over a period of 35 weeks?
9. A local supermarket has a special on tins of baked beans. If you buy four tins, you only have to pay for three tins. The price of one tin of baked beans is R6,15. Mr Fourie put 6 dozen tins in his shopping trolley. How much did he pay? 1 dozen tins = 12 tins
10. There are *about* 42 beans in one cacao pod. *About* 123 cacao beans are needed to make 1 kg of chocolate. *About* how many pods are needed for 14 kg of chocolate?

11.6 More calculations in real life

1. Shop A has 53 glass jars in stock. Shop B has 18 times more glass jars in stock than Shop A. How many glass jars are available between the two shops?
2. Yaro had R50. He bought sweets for R12 and three ice lollies for R12 each. How much money was left over?
3. A theatre has 62 rows with 28 seats in every row. On Saturday night 690 tickets were sold at the door. If the show was a complete sell out, how many tickets were sold *before* Saturday night?

Teaching guidelines

The situations in questions 4, 5, 6 and 8 are complicated in the sense that they all require more than one operation. Suggest to learners that they read each question carefully and write a calculation plan before they start to do the calculations. Also suggest to them that they do not start calculating immediately when they have written a calculation plan, but first think critically about the plan they have written and check whether it corresponds to the situation described in the question.

Notes on questions

Calculation plans for the different questions are given below.

Question 4: $16 \times 8 \times 3 + 17 \times 7 \times 3$

16 (round tables) $\times 8$ (places) $\times 3$ (glasses) + 17 (rectangular tables) $\times 7$ (places) $\times 3$ (glasses)

Question 5: $124 \times 37 + 192 \times 67$

Question 6: $5 \times 28 + 4 \times 24 + 3 \times 25$

Question 7(a): 47×18

Question 8: $18 \times 149 - 13 \times 165$

Answers

4. $3 \times (16 \times 8 + 17 \times 7) = 741$ glasses

5. R17 452

6. 311 learners

7. (a) 846 T-shirts (b) 9 boxes

8. R537

4. Waiters are setting tables for a dinner function. Sixteen round tables are set with 8 places each and 17 rectangular tables are set with 7 places each. At each of the places, 3 glasses are arranged. How many glasses are put on the tables altogether?



5. Wilhelmina and her daughters knit scarfs and caps for an income. They sell the caps for R124 each and the scarfs for R192 each. They have an order for 37 caps and 67 scarfs. How much is their income from this order?
6. When the National Cycling Championship took place and the cyclists passed Star Primary School, 12 classes went outside to watch. Five classes of 28 learners each, four classes of 24 learners each and three classes of 25 learners each cheered the cyclists on. Altogether, how many learners were outside?
7. Bike Bonanza sponsors T-shirts for first-time entries in the cross-country cycling race. Last year there were 47 cyclists who took part in the race for the first time. This year 18 times more newcomers entered than last year.
- (a) How many T-shirts must Bike Bonanza have ready on the day of the race?
- (b) The T-shirt company only sells boxes of 100 T-shirts each. How many boxes must Bike Bonanza order?
8. Mrs Singh bought 18 books at a book sale. She paid R149 for each book. She later sold 13 of the books to a secondhand bookshop for R165 each. What is the difference between the total amount of money she bought the books for and the total amount of money she sold the books for?

Term 4

Unit 1: Whole numbers	311
1.1 Order and represent numbers	312
1.2 Investigate even and odd numbers	315
Unit 2: Whole numbers: Addition and subtraction	316
2.1 Revision and practice	317
2.2 Add and subtract in context	320
2.3 Rounding off in context	321
Unit 3: Properties of three-dimensional objects	326
3.1 Rectangular prisms	327
3.2 Nets of rectangular prisms	328
3.3 Nets of other prisms	331
3.4 Nets of a square-based pyramid	333
3.5 Nets of a cylinder and a cone	334
Unit 4: Common fractions	336
4.1 Fractions of whole numbers	337
4.2 Fractions in diagrams	340
4.3 Fractions on the number line	342
4.4 Solving problems	343
Unit 5: Whole numbers: Division	346
5.1 Revision practice	347
5.2 Making pictures smaller and bigger	348
5.3 Ratios of enlargement and reduction	349
5.4 Ratio again	352
Unit 6: Perimeter, area and volume	355
6.1 Perimeter	357
6.2 Area	361
6.3 Volume and capacity	365

Unit 7: Position and movement	369
7.1 Moving between positions on a grid map	370
Unit 8: Transformations	372
8.1 Rotations, reflections and translations in art	373
8.2 Tessellations	375
Unit 9: Geometric patterns	378
9.1 Making a geometric pattern	379
9.2 Describing patterns	380
9.3 Completing tables	382
Unit 10: Number sentences	383
10.1 Solve and complete number sentences by trial and improvement	384
10.2 Flow diagrams, number sentences and tables	386
Unit 11: Probability	388
11.1 A coin-tossing experiment	389
11.2 Spinner Experiment 1	390
11.3 Spinner Experiment 2	392

Learner Book Overview		
Sections in this unit	Content	Pages in Learner Book
1.1 Order and represent numbers	Arranging numbers in ascending and descending order, writing number names, and writing numbers in expanded notation	283 to 284
1.2 Investigate even and odd numbers	Investigating given hypotheses about even and odd numbers	285

CAPS time allocation	1 hour
CAPS page references	13 to 15 and 196

Mathematical background

Any even number can be written in the form $2n$, where n is a natural number, and any number that can be written in the form $2n$ is an even number.

Any odd number can be written in the form $2n + 1$, where n is a natural number, and any number that can be written in the form $2n + 1$ is an odd number.

	These examples use $m = 15$ and $n = 8$, but any other whole numbers could have been used for m and n .
The sum of any two even numbers, $2m$ and $2n$, is an even number because $2m + 2n = 2(m + n)$	$2 \times 15 + 2 \times 8 = 2 \times (15 + 8)$ $2 \times (15 + 8)$ is an even number, 2 is one of its factors
The sum of any two odd numbers, $2m + 1$ and $2n + 1$, is an even number because $2m + 1 + 2n + 1 = 2m + 2n + 2 = 2(m + n + 1)$	$2 \times 15 + 1 + 2 \times 8 + 1 = 2 \times 15 + 2 \times 8 + 1 + 1$ $= 2 \times (15 + 8) + 2$ $= 2 \times (15 + 8 + 1)$, an even number
The sum of any odd number, $2m + 1$, and any even number, $2n$, is an odd number because $2m + 1 + 2n = 2m + 2n + 1 = 2(m + n) + 1$	$2 \times 15 + 1 + 2 \times 8 = 2 \times 15 + 2 \times 8 + 1$ $= 2 \times (15 + 8) + 1$, an odd number
The difference between any two even numbers, $2m$ and $2n$, is an even number because $2m - 2n = 2(m - n)$	$2 \times 15 - 2 \times 8 = 2 \times (15 - 8)$ $2 \times (15 - 8)$ is an even number
The difference between any two odd numbers, $2m + 1$ and $2n + 1$, is an even number because $2m + 1 - (2n + 1) = 2m + 1 - 2n - 1 = 2m - 2n = 2(m - n)$	$2 \times 15 + 1 - (2 \times 8 + 1) = 2 \times 15 + 1 - 2 \times 8 - 1$ $= 2 \times 15 - 2 \times 8$ $= 2 \times (15 - 8)$, an even number
The difference between any odd number, $2m + 1$, and any even number, $2n$, is an odd number because $2m + 1 - 2n = 2m - 2n + 1 = 2(m - n) + 1$	$2 \times 15 + 1 - 2 \times 8 = 2 \times 15 - 2 \times 8 + 1$ $= 2 \times (15 - 8) + 1$, an odd number

An algebraic treatment of even and odd numbers, like the above, is not required in Grade 5. *The above is given for your benefit only.*

In Section 1.2 learners will engage with the above properties of even and odd numbers by means of examples.

1.1 Order and represent numbers

Teaching guidelines

Questions 1 to 6 may be utilised as a **diagnostic assessment** instrument.

Answers

- 120 000 120 400 120 800 121 200 121 600 122 000
122 400 122 800 123 200
- 222 000 224 000 226 000 228 000 230 000 232 000
234 000 236 000 238 000 240 000 242 000 244 000
- | | | | | |
|---------|---------|-----------|-----------|-----------|
| 120 000 | 160 000 | 200 000 | 240 000 | 280 000 |
| 320 000 | 360 000 | 400 000 | 440 000 | 480 000 |
| 520 000 | 560 000 | 600 000 | 640 000 | 680 000 |
| 720 000 | 760 000 | 800 000 | 840 000 | 880 000 |
| 920 000 | 960 000 | 1 000 000 | 1 040 000 | 1 080 000 |
- 101 000 104 000 107 000 110 000 113 000 116 000 119 000
- 195 123 201 065 298 829 439 365 477 677 686 132 786 987
- 903 546 865 199 865 153 831 001 721 122 258 121 127 140

UNIT

1

WHOLE NUMBERS

1.1 Order and represent numbers

- Count in four hundreds from 120 000 until you pass 123 000. Write down the number symbols as you go along.
- Count in two thousands from 222 000 until you reach 244 000. Write down the number symbols as you go along.
- Copy the number grid and fill in all the numbers. You have to count in 40 000s to do this.

120 000	160 000	200 000		
				480 000
520 000				
		800 000		
			1 040 000	

- Which numbers are missing at the marks on this number line? Write the numbers from smallest to biggest in your book. You have to count in 3 000s to do this.



- Arrange the following seven numbers in ascending order (from smallest to biggest).
686 132 786 987 195 123 298 829
201 065 477 677 439 365
- Arrange the following seven numbers in descending order (from biggest to smallest).
127 140 903 546 865 153 721 122
258 121 865 199 831 001

Teaching guidelines

Question 7 is of a different nature than the other questions in this section. It is meant to provide learners with some opportunities to think smartly.

Question 7(a) can be done by writing all the numbers from 1 to 1 000 and counting how many of them are odd. Learners could be challenged to think of a smarter way of finding the number of odd numbers. Learners who do not make progress can be supported by asking them how many numbers in total there are from 1 to 1 000. Some learners may be unsure about this. Ask them how many numbers there are from 1 to 10. They may think that it may be 10, but they may be unsure. In this case they can quickly check by writing the numbers down and counting them:

1 2 3 4 5 6 7 8 9 10

At this point, ask these learners how many numbers they think there are from 1 to 20. They may be more confident now that it is 20. Now ask them how many odd numbers there are between 1 and 10, and between 1 and 20. This may put their minds on a path towards answering question 7(a) with confidence.

Answers

7. (a) 500 (b) 999 (excluding 10 000)
(c) 499 999 (excluding 1) (d) 99 999 (excluding 1 000 000)
(e) 333 333

8. (a) $100\ 000 + 20\ 000 + 4\ 000 + 500 + 60 + 5$ 124 565
(b) $200\ 000 + 10\ 000 + 700 + 60 + 3$ 210 763
(c) $400\ 000 + 1\ 000 + 800 + 7$ 401 807
(d) $700\ 000 + 10\ 000 + 1\ 000 + 300 + 10 + 2$ 711 312
(e) $100\ 000 + 20\ 000 + 7\ 000 + 700 + 90 + 5$ 127 795
(f) $900\ 000 + 90\ 000 + 6\ 000 + 600 + 6$ 996 606

9. and 10. See next page.

7. (a) How many whole numbers between 0 and 1 000 are odd?
(b) How many whole numbers between 0 and 10 000 are multiples of 10?
(c) How many whole numbers between 1 and 1 million are odd?
(d) How many whole numbers between 1 and 1 million are multiples of 10?
(e) How many whole numbers between 1 and 1 million are multiples of 3?
8. Write the expanded notations *and* number symbols for these numbers.
(a) hundred and twenty-four thousand, five hundred and sixty-five
(b) two hundred and ten thousand, seven hundred and sixty-three
(c) four hundred and one thousand, eight hundred and seven
(d) seven hundred and eleven thousand, three hundred and twelve
(e) one hundred and twenty-seven thousand, seven hundred and ninety-five
(f) nine hundred and ninety-six thousand, six hundred and six
9. Write the expanded notations and number names for these numbers.
(a) 216 786 (b) 785 092 (c) 670 548
(d) 108 805 (e) 632 104 (f) 405 696
10. Round off each of the numbers in question 9 to the nearest:
(a) five
(b) ten
(c) hundred
(d) thousand.

Answers (continued)

9. (a) $200\ 000 + 10\ 000 + 6\ 000 + 700 + 80 + 6$
two hundred and sixteen thousand seven hundred and eighty-six
- (b) $700\ 000 + 80\ 000 + 5\ 000 + 90 + 2$
seven hundred and eighty-five thousand and ninety-two
- (c) $600\ 000 + 70\ 000 + 500 + 40 + 8$
six hundred and seventy thousand five hundred and forty-eight
- (d) $100\ 000 + 8\ 000 + 800 + 5$
one hundred and eight thousand eight hundred and five
- (e) $600\ 000 + 30\ 000 + 2\ 000 + 100 + 4$
six hundred and thirty-two thousand one hundred and four
- (f) $400\ 000 + 5\ 000 + 600 + 90 + 6$
four hundred and five thousand six hundred and ninety-six

10.

Rounded off to the nearest...	(a) five	(b) ten	(c) hundred	(d) thousand
(a) 216 786	216 785	216 790	216 800	217 000
(b) 785 092	785 090	785 090	785 100	785 000
(c) 670 548	670 550	670 550	670 500	671 000
(d) 108 805	108 805	108 810	108 800	109 000
(e) 632 104	632 105	632 100	632 100	632 000
(f) 405 696	405 695	405 700	405 700	406 000

7. (a) How many whole numbers between 0 and 1 000 are odd?
(b) How many whole numbers between 0 and 10 000 are multiples of 10?
(c) How many whole numbers between 1 and 1 million are odd?
(d) How many whole numbers between 1 and 1 million are multiples of 10?
(e) How many whole numbers between 1 and 1 million are multiples of 3?
8. Write the expanded notations *and* number symbols for these numbers.
(a) hundred and twenty-four thousand, five hundred and sixty-five
(b) two hundred and ten thousand, seven hundred and sixty-three
(c) four hundred and one thousand, eight hundred and seven
(d) seven hundred and eleven thousand, three hundred and twelve
(e) one hundred and twenty-seven thousand, seven hundred and ninety-five
(f) nine hundred and ninety-six thousand, six hundred and six
9. Write the expanded notations and number names for these numbers.
(a) 216 786 (b) 785 092 (c) 670 548
(d) 108 805 (e) 632 104 (f) 405 696
10. Round off each of the numbers in question 9 to the nearest:
(a) five
(b) ten
(c) hundred
(d) thousand.

1.2 Investigate even and odd numbers

Teaching guidelines

As an introduction you may ask learners to mention some even numbers and some odd numbers, and write them in separate places on the board. Then say to learners that you have a number in mind and will write it on the board later. Ask them to identify a question that they could ask you that will enable them to determine whether the number you have in mind is an odd number or an even number. Allow learners to discuss this in small groups and agree on a question to ask. Visit the groups and ask each group to tell you the question they have decided on. This will provide insight into your learners' understanding of the difference between odd and even numbers.

Explain the following two methods to decide whether a number is odd or even, as well as any other correct strategies mentioned by learners:

- Look at the last digit: if the last digit is 0; 2; 4; 6 or 8, the number is even. If the last digit is 1; 3; 5; 7 or 9, the number is odd.
- Ask whether the number is the double of another number: if it is, it is even; if it is not, it is odd.

To further develop learners' understanding of even and odd numbers, you may write a set of consecutive whole numbers on the board, for example:

15 16 17 18 19 20 21 22 23 24 25 26 27 28 29 30 31 32 33 34

Then double each number:

30 32 34 36 38 40 42 44 46 48 50 52 54 56 58 60 62 64 66 68

Then add 1 to each number:

31 33 35 37 39 41 43 45 47 49 51 53 55 57 59 61 63 65 67 69

If there is time, ask learners to explain *why* each of the true statements in questions 3 and 4 is true. For question 3 they may argue that an odd number is an even number plus one, hence an odd number + an odd number = an even number + 1 + another even number + 1 = sum of two even numbers + 2. They may then argue that the sum of two even numbers is an even number.

Answers

1. Any whole number is either odd or even. No number can be both odd and even.
2. (a) 94 156 722 (b) 95 157 723
3. Yes; any five examples in which two odd numbers are added, e.g. $9 + 11 = 20$
4. (a) True; e.g. $5 + 4 = 9$ (b) False; e.g. $13 + 1 + 3 = 17$
(c) True; e.g. $1 + 3 = 4$; $13 + 15 + 17 + 19 = 64$
(d) True; e.g. $3 + 7 + 9 = 19$; $1 + 17 + 33 + 5 + 11 = 67$
(e) False; e.g. $45 - 13 = 32$ (f) True; e.g. $44 - 12 = 32$

1.2 Investigate even and odd numbers

An **even number** is formed when any whole number is doubled (multiplied by 2), for example:

$$2 \times 37 = 74, 2 \times 459 = 918 \text{ and } 2 \times 344\,924 = 689\,848$$

74 and 918 and 689 848 are all even numbers.

The *units part* of any even number is 0, 2, 4, 6 or 8.

An **odd number** is formed by adding 1 to an even number, for example:

$$74 + 1 = 75, 918 + 1 = 919 \text{ and } 689\,848 + 1 = 689\,849$$

75 and 919 and 689 849 are all odd numbers.

The *units part* of any odd number is 1, 3, 5, 7 or 9.

1. Can you think of a number that is not odd, and also not even?
2. (a) In each case, form an even number by doubling.
47 78 361
(b) Add 1 to each of your even numbers to form an odd number.
3. Is it true that when two odd numbers are added, the result is always an even number? Give *five* examples to support your answer.
4. Decide whether the statement is true or false. Give *one* example if the statement is false and *five* examples if the statement is true.
 - (a) When an *odd* number and an *even* number are added, the result is always an odd number.
 - (b) When *any three odd* numbers are added, the result is an even number.
 - (c) When any *even number* of odd numbers are added, the result is an even number.
 - (d) When any *odd number* of odd numbers are added, the result is an odd number.
 - (e) The difference between two odd numbers is an odd number.
 - (f) The difference between two even numbers is an even number.

Learner Book Overview		
Sections in this unit	Content	Pages in Learner Book
2.1 Revision and practice	Revision and practice of subskills for addition and subtraction	286 to 288
2.2 Add and subtract in context	Solving word problems	289 to 290
2.3 Rounding off in context	An investigation that involves estimation, rounding off and calculation	290 to 291

CAPS time allocation	5 hours
CAPS page references	13 to 15 and 197

Mathematical background

When adding and subtracting multi-digit numbers by breaking down and building up, it is often necessary to replace the place value expansion of a number with a different expansion or to replace an expansion with the standard place value expansion. For example:

- When calculating $8\,253 - 3\,768$, the place value expansion $8\,000 + 200 + 50 + 3$ of $8\,253$ is inconvenient because it is problematic to subtract 8 from 3, 60 from 50 and 700 from 200. Hence it is useful to replace $8\,000 + 200 + 50 + 3$ with $7\,000 + 1\,100 + 140 + 13$.
- During the calculation of $5\,687 + 8\,865$ by breaking down and building up, the expansion $13\,000 + 1\,400 + 140 + 12$ of the sum is replaced by the standard place value expansion $10\,000 + 4\,000 + 500 + 50 + 2$, in order to write the answer as the single number 14 552.

Replacements like the above were explicitly shown in the exposition formats that learners used in Terms 1 and 2; hence it was easy for learners to keep in touch with the underlying logic when doing calculations. However, in the abbreviated exposition formats learners may be using by Term 4 (vertical column exposition) they may easily lose sight of the replacements that provide the logical basis for the various steps, and the actual meaning of the digits they act upon (i.e. lose sight of place value).

2.1 Revision and practice

Teaching guidelines

Questions 1 to 4 provide opportunities to engage learners in some sharp thinking.

To utilise these opportunities, ask learners to read the whole of question 1 and to identify whether they *expect* any of the sub-questions (a), (b), (c), (d) and (e) to have the same answers. Once they have begun to consider this possibility, ask them to look specifically at questions (d) and (e), and to try to anticipate whether these two calculation plans may produce the same answer, or not.

Allow learners a few minutes to engage with 1(d) and (e). Then show them how the answers can be obtained by making transfers between place value positions. This can be done in various ways, for example:

$$\begin{aligned} 1. \quad (d) \quad & 40\,000 + 13\,000 + 1\,700 + 340 + 17 \\ & = 40\,000 + 14\,000 + 700 + 350 + 7 \\ & = 50\,000 + 4\,000 + 1\,000 + 50 + 7 \\ & = 50\,000 + 5\,000 + 50 + 7 = \mathbf{55\,057} \end{aligned}$$

$$\begin{aligned} 1. \quad (e) \quad & 40\,000 + 3\,000 + 10\,700 + 1\,340 + 17 \\ & = 43\,000 + 11\,700 + 340 + 17 \\ & = 54\,000 + 700 + 300 + 50 + 7 \\ & = 54\,000 + 1\,000 + 50 + 7 = \mathbf{55\,057} \end{aligned}$$

Answers

- (a) 30 406 (b) 34 060 (c) 34 006 (d) 55 057 (e) 55 057
- (a) 30 000 (b) 73 848 (c) 90 000 (d) 30 000 (e) 130 000 (f) 30 000
- (a) 63 951 (b) 63 951 (c) 63 951 (d) 63 951 (e) 63 951
- (a) 54 901 (b) 62 744 (c) 25 876 (d) 25 876 (e) 60 001

UNIT

2

WHOLE NUMBERS:

ADDITION AND SUBTRACTION

2.1 Revision and practice

- Write as single numbers.
 - $30\,000 + 400 + 6$
 - $30\,000 + 4\,000 + 60$
 - $30\,000 + 4\,000 + 6$
 - $40\,000 + 13\,000 + 1\,700 + 340 + 17$
 - $40\,000 + 3\,000 + 10\,700 + 1\,340 + 17$
- How much is each of the following?
 - $8\,000 + 7\,000 + 4\,000 + 8\,000 + 3\,000$
 - $800 + 70\,000 + 40 + 8 + 3\,000$
 - $20\,000 + 40\,000 + 30\,000$
 - $70\,000 - 40\,000$
 - $170\,000 - 40\,000$
 - $170\,000 - 140\,000$
- Write as single numbers.
 - $60\,000 + 3\,000 + 900 + 50 + 1$
 - $952 + 62\,999$
 - $3\,952 + 59\,999$
 - $50\,000 + 12\,000 + 1\,800 + 140 + 11$
 - $50\,000 + 13\,000 + 900 + 40 + 11$
- How much is each of the following?
 - $7\,843 + 7\,843 + 7\,843 + 7\,843 + 7\,843 + 7\,843 + 7\,843$
 - $7\,843 + 7\,843 + 7\,843 + 7\,843 + 7\,843 + 7\,843 + 7\,843 + 7\,843$
 - $34\,725 - 18\,847 + 44\,718 - 34\,720$
 - $34\,725 - 34\,720 + 44\,718 - 18\,847$
 - $73\,548 - 23\,456 + 43\,457 - 33\,548$

Teaching guidelines

Apart from practice in estimation, question 5 also serves the purpose of inducing learners to apply their minds to careful reading and interpretation of the problem statements, and to alert them again to different meanings of subtraction.

Question 5(a), (b) and (c) may challenge learners for two reasons:

- They may be unsure how to go about making estimates instead of doing the calculations.
- They may find it difficult to figure out what operations to use.

If learners do not make good progress, you may suggest that they **round off the given numbers** to the nearest ten thousand and write number sentences as a way of interpreting the problem statements. You may demonstrate with (a):

$$\text{A certain number} + 20\,000 = 60\,000$$

Answers

5. (a) 40 000 (b) 80 000 (c) 80 000
 6. (a) 36 022; 40 000 (b) 83 556; 80 000 (c) 83 556; 80 000
 7. (a) and (b) Not useful
 (c) The calculation can be done as shown on the right.

59 999
- 19 826
40 173
+ 3 952
44 125

The calculations in (d) and (e) can be done as shown below.
 Learners may record the same reasoning differently.

(d)	50 000	12 000	1 800	140	11	(e)	50 000	13 000	900	40	11
	<u>-10 000</u>	<u>-9 000</u>	<u>-800</u>	<u>-20</u>	<u>-6</u>		<u>-10 000</u>	<u>-9 000</u>	<u>-800</u>	<u>-20</u>	<u>-6</u>
	40 000	3 000	1 000	120	5		40 000	4 000	100	20	5

8. (a) $6 + 6 + 7 + 5 = 24$ (b) $70 + 40 + 80 + 40 = 230$
 (c) $800 + 200 + 300 + 800 = 2\,100$ (d) $3\,000 + 9\,000 + 8\,000 + 7\,000 = 27\,000$
 (e) $20\,000 + 20\,000 = 40\,000$ (f) 69 354
 9. (a) Example: $3\,800 \times 10 + (23 + 12 + 7 + 35 + 23 + 32 + 61 + 14 + 41 + 21)$
 (b) $38\,000 + 269 = 38\,269$

5. Do not calculate the answers to these questions now. Just estimate the answers to the nearest 10 000.
 (a) 23 767 is added to a certain number and the answer is 59 789. What is this number?
 (b) 23 767 is subtracted from a certain number and the answer is 59 789. What is this number?
 (c) A certain number is 23 767 more than 59 789. What is this number?
 6. Calculate the exact answers for question 5. Then round off your answers to the nearest 10 000.
 7. Which of the following will be useful replacements for 63 951 if you have to calculate $63\,951 - 19\,826$? Explain your choices by showing how you would do the calculation with each of your choices.
 (a) $63\,951 = 60\,000 + 3\,000 + 900 + 50 + 1$
 (b) $63\,951 = 952 + 62\,999$
 (c) $63\,951 = 3\,952 + 59\,999$
 (d) $63\,951 = 50\,000 + 12\,000 + 1\,800 + 140 + 11$
 (e) $63\,951 = 50\,000 + 13\,000 + 900 + 40 + 11$
 8. $23\,876 + 9\,246 + 28\,387 + 7\,845$ can be calculated as shown on the right.

23 876
9 246
28 387
+ 7 845
49 354

 State which numbers were added to obtain each of the part answers in red.
 Also write the final answer.
 24 (a)
 230 (b)
 2 100 (c)
 27 000 (d)
 40 000 (e)
 (f)
 9. (a) Can you think of a quick way to find the answer for $3\,823 + 3\,812 + 3\,807 + 3\,835 + 3\,823 + 3\,832 + 3\,861 + 3\,814 + 3\,841 + 3\,821$?
 (b) Find the answer.

Teaching guidelines

It is important that learners write their predictions for question 12 down, so that they can check them once they have done question 13.

Questions 12 and 14 provide very good opportunities for learners to talk about computation. Expressing their own ideas about numbers and computation can substantially enrich learners' understanding, knowledge and skills.

Assemble learners who have finished question 12 individually in small groups, before they do question 13. Ask them to tell each other why they believe some calculation plans will produce the same answer and others not. They do not need to reach agreement.

Also assemble learners who have completed question 14 individually in groups. Ask them to explain to each other how they developed the answer for each column. Some possible ways of doing it are described below.

Notes on questions

Allow learners to look for short methods themselves when doing question 14. Learners who do not identify short methods can do the questions by calculating normally.

14. (a) The first four numbers can be added, and the answer can be doubled.
 14. (b) The sum of the first five numbers is $5 \times 8\,554 - (2 + 4 + 6 + 8)$
 The sum of the last five numbers is $5 \times 8\,554 + (2 + 4 + 6 + 8) + 10$
 So the sum of all the numbers is $10 \times 8\,554 + 10 = 85\,540 + 10 = 85\,550$
 There are also other ways to shorten the work, and to record it.
 14. (c) $10 \times 7\,234 = 72\,340$
 14. (d) $10 \times 6\,762 - 6\,762 = 67\,620 - 6\,762 = 60\,858$
 14. (e) $6\,324 + 3\,676 = 10\,000$ and $10\,000 \times 5 = 50\,000$

Answers

10. (a) $52\,643 + 32\,849 = 85\,492$, so the answer is incorrect.
 (b) The smaller digits were subtracted from the larger digits.
 11. (a) No, it should be 24 579.
 (b) The person forgot to add 2 844, because $42\,843 = 39\,999 + 2\,844$.
 12. (b) and (c) will have the same answers.
 (a) and (d) will have the same answers.
 13. (a) 53 906 (b) 45 436 (c) 45 436 (d) 53 906
 14. See "Notes on questions" above for more information on this question.
 (a) 130 616 (b) 85 550 (c) 72 340 (d) 60 858 (e) 50 000

10. On the right you can see what someone wrote to calculate $84\,286 - 32\,849$.

$$\begin{array}{r} 84\,286 \\ - 32\,849 \\ \hline 52\,643 \end{array}$$

- (a) Check the answer by doing addition.
 (b) If the answer is incorrect, explain what the person may have done to get it wrong.

11. On the right you can see what someone wrote to calculate $42\,843 - 18\,264$.

$$\begin{array}{r} 39\,999 \\ - 18\,264 \\ \hline 21\,735 \end{array}$$

- (a) Do you think the answer is correct?
 (b) If the answer is incorrect, explain what the person did to get it wrong.

12. Which of the following *do you think* will have the same answer?

- (a) $88\,547 - 63\,488 + 72\,723 - 43\,876$
 (b) $88\,547 - 72\,723 + 73\,488 - 43\,876$
 (c) $88\,547 - 43\,876 + 73\,488 - 72\,723$
 (d) $88\,547 - 43\,876 + 72\,723 - 63\,488$

13. Do the calculations in question 12 to check your predictions.

14. Find the sum of the numbers in each column. Do it with as little work as possible.

(a)	(b)	(c)	(d)	(e)
21 856	8 546	7 234	6 762	6 324
8 235	8 548	7 234	6 762	3 676
679	8 550	7 234	6 762	6 324
34 538	8 552	7 234	6 762	3 676
21 856	8 554	7 234	6 762	6 324
8 235	8 556	7 234	6 762	3 676
679	8 558	7 234	6 762	6 324
34 538	8 560	7 234	6 762	3 676
	8 562	7 234	6 762	6 324
	8 564	7 234		3 676

2.2 Add and subtract in context

Teaching guidelines

Some learners may read question 1 without comprehension and add the two numbers to produce 139 131, which is wrong. Suggest to these learners that they write number sentences to represent the situations described in questions 1 and 2. Ask learners to now describe the difference between these two number sentences.

After learners have spent some time working on questions 1 and 2, you may write the following general number sentence on the board and ask learners to describe the difference between questions 1 and 2 by referring to this number sentence:

$$58\,700 - 2\,600 = 56\,100$$

They may do this by talking in small groups.

Notes on questions

For question 4(a) some learners may round the given figures off to the nearest 10 000:

$$20\,000 + 10\,000 + 20\,000 + 10\,000 + 20\,000 = 80\,000$$

Other learners may round off to the nearest thousand:

$$24\,000 + 12\,000 + 19\,000 + 14\,000 + 16\,000 = 85\,000,$$

which rounded to the nearest ten thousand gives 90 000.

The actual sum is 84 913.

Answers

- 3 397
- 63 226
- 20 389
 - End of 2013: 79 021
End of 2014: 72 643
End of 2015: 63 939
 - $63\,939 + 20\,389 = 84\,328$ or $84\,328 - 20\,389 = 63\,939$
- 80 000 votes (b) A, C, E (c) 84 913 votes
 - 9 386 votes (e) 1 662 votes
- 89 102 learners

2.2 Add and subtract in context

- During 2013, the population of Town A increased from 67 867 to 71 264. What was the population increase?
- At the beginning of 2013, the population of Town B was 56 692. The population increased by 6 534 during the year. What was the population at the end of 2013?
- At the beginning of 2013, the population of Town C was 84 328. The population decreased by 5 307 during 2013. During 2014 it decreased by 6 378 and during 2015 by 8 704.
 - What was the total decrease over the three years?
 - What was the population of Town C at the end of 2013, at the end of 2014 and at the end of 2015?
 - Use your answer for (a) to check your answer for the last part of question (b).
- Here are the results of a local election, for three positions on a Council:
Candidate A: 23 713 votes
Candidate B: 11 908 votes
Candidate C: 18 976 votes
Candidate D: 14 327 votes
Candidate E: 15 989 votes
 - Estimate the total number of votes to the nearest 10 000.
 - Which three candidates won seats on the Council?
 - How many votes were cast in total?
 - How many more votes than Candidate D did Candidate A get?
 - What is the difference between the number of votes for Candidates D and E?
- A provincial document shows that 78 866 learners attended Grade 1 last year, while 10 236 more were enrolled at the beginning of this year. How many learners were enrolled this year?

Answers

6. 70 456 ℓ 7. Decreased by 10 369 8. 389 votes

2.3 Rounding off in context

Teaching guidelines

This section comprises an **investigation** that provides extensive practice in rounding off, estimation, and calculation. Engaging in this activity may also lead to learners forming a rough idea of what they will later come to know as the mean or “average” of a set of numbers. The purpose of the activity is to explore ways in which a good estimate of the sum of all the numbers in the table can be made without actually adding the numbers up.

Learners can begin working on this investigation in class, but they should preferably spend substantial time at home taking their work further.

It is important that all learners quickly get a sense of the range of data in the table. You may help them to do this by asking them how many schools are represented in the table ($6 \times 13 = 78$), and to identify the smallest and the largest numbers (301 and 879). Once that is done, you may ask them to consider whether the total number of learners in all 78 schools is:

- smaller than 78×300
- between 78×300 and 78×900 or
- bigger than 78×900 .

Reflecting on this question, and discussing it, will prepare learners for engaging with questions 1 to 7 on the next page.

The table below is for your convenience. It contains the same numbers as the table on Learner Book page 290 (see alongside), but here the numbers are arranged from smallest to largest in each column.

307	304	352	301	352	335
313	403	393	404	379	336
314	430	457	448	397	346
339	463	486	481	402	352
355	485	492	483	406	377
361	521	498	521	539	421
399	574	571	530	554	446
485	574	571	582	583	480
550	574	586	771	708	480
589	582	593	787	708	493
589	633	691	845	718	533
636	829	741	845	783	584
767	878	792	871	879	836

6. On a hot day, 23 756 ℓ of water from a small farm dam is used for irrigation. At the end of the day, there is 46 700 ℓ left. How much water was in the dam at the beginning of the day?
7. At the time of the 2011 election, there were 63 458 registered municipal voters. At the time of the 2015 election, there were 53 089 voters. Did the number of voters increase or decrease, and by how many?
8. During a local election, 98 065 people voted for the Green Party and 97 676 people voted for the Anti-Corruption Party. By how many votes did the Green Party win?

2.3 Rounding off in context

The numbers of learners in the different schools in a certain region are given in the table below.

589	574	571	845	708	480
485	403	486	481	352	377
767	521	741	483	879	421
339	430	393	404	402	352
636	829	593	771	539	584
307	485	457	530	583	336
355	633	792	582	406	335
399	463	586	521	379	533
314	574	352	871	783	493
550	582	498	301	397	346
361	878	691	787	718	836
313	304	492	448	554	446
589	574	571	845	708	480

How can you quickly make a good estimate of the total number of learners in these schools?

Teaching guidelines

Note that questions 1(a) and 2(a) are very different: 1(a) asks for **the quickest plan**, while 2(a) asks for **the plan that will produce the best estimate**.

There can be little argument that Plan A is the quickest.

Once learners have completed or are working on question 2(b), interrupt their work and ask them to explain to two classmates why they believe the plan they have chosen will produce a good estimate of the total number of learners in all 78 schools.

If learners find it too challenging to choose a representative number when they try to implement Plan C (question 4(b)), you may let them make a table in which the numbers are arranged from smallest to largest in each column, as in the table provided on the previous page of this Teacher Guide. When considering the middle row in this reorganised table, learners may think of selecting a number between 500 and 600.

Notes on questions

Plans A to D will produce the following answers.

Plan A: $6 \times 13 \times 500 = 78 \times 500 = 39 \times 1\,000 = 39\,000$

Plan B: $6 \times 13 \times 600 = 78 \times 600 = 46\,800$

Plan C: The estimate depends on the number chosen as a representative number. If the number chosen is between 300 and 800, the answer will be between 23 400 and 62 400.

Plan D: Column totals from left to right: 6 004, 7 250, 7 223, 7 869, 7 408 and 6 109

The estimates based on the different column totals are:

36 024, 43 500, 43 338, 47 124, 44 448 and 36 114.

Plan E: A table with rounded numbers is given on page 324 of this Teacher Guide.

Plan F: A table with the hundreds parts only is given on page 325 of this Teacher Guide.

Answers

1. There can be little argument that Plan A is the quickest plan.
2. Learners choose a plan for the best estimate and carry out the plan. Answers will differ.
3. Learners choose a plan for the worst estimate and carry out the plan. Answers will differ.
4. Different plans are used and hence answers will differ.
5. 41 773
6. Learners choose their best estimate.
7. Consider learners' plans.

Here are some plans:

- A. Multiply the number of schools by 500.
- B. Multiply the number of schools by 600.
- C. Multiply the number of schools by some other number you decide on.
- D. Add up the numbers in one column and multiply by 6.
- E. Round off each number to the nearest hundred and work from there.
- F. Work with the hundreds parts of the numbers only.

Answer the following questions.

1. (a) Which plan do you think will be quickest to follow?
(b) Carry out this plan.
2. (a) Which plan do you think will produce the best estimate of the total number of learners?
(b) Carry out this plan.
3. (a) Which plan do you think will produce the worst estimate of the total number of learners?
(b) Carry out this plan.
4. (a) Carry out any other one of the given plans.
(b) If you have not used Plan C yet, do it now.
5. Add up all the numbers in the table.
6. You made four or five estimates of the actual total number of learners. Which was the best estimate?
7. Can you think of a better plan to make an estimate than any of the plans given above?

Plans E and F

Learners may use tables like the one below to list the rounded off numbers for Plan E, and the hundreds parts only of the numbers for Plan F.

	589		574		571		845		708		480
	485		403		486		481		352		377
	767		521		741		483		879		421
	339		430		393		404		402		352
	636		829		593		771		539		584
	307		485		457		530		583		336
	355		633		792		582		406		335
	399		463		586		521		379		533
	314		574		352		871		783		493
	550		582		498		301		397		346
	361		878		691		787		718		836
	313		304		492		448		554		446
	589		574		571		845		708		480

Plan E: The numbers rounded off to the nearest 100

600	589	600	574	600	571	800	845	700	708	500	480
500	485	400	403	500	486	500	481	400	352	400	377
800	767	500	521	700	741	500	483	900	879	400	421
300	339	400	430	400	393	400	404	400	402	400	352
600	636	800	829	600	593	800	771	500	539	600	584
300	307	500	485	500	457	500	530	600	583	300	336
400	355	600	633	800	792	600	582	400	406	300	335
400	399	500	463	600	586	500	521	400	379	500	533
300	314	600	574	400	352	900	871	800	783	500	493
600	550	600	582	500	498	300	301	400	397	300	346
400	361	900	878	700	691	800	787	700	718	800	836
300	313	300	304	500	492	400	448	600	554	400	446
600	589	600	574	600	571	800	845	700	708	500	480

The rounded numbers can be analysed like this:

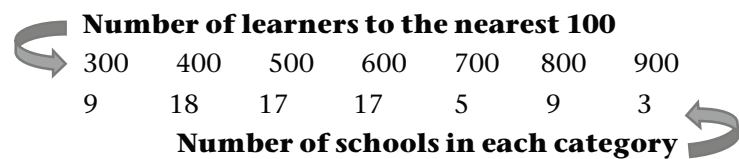

The above information can be used to estimate the total number of learners as:

$9 \times 300 + 18 \times 400 + 17 \times 500 + 17 \times 600 + 5 \times 700 + 9 \times 800 + 3 \times 900$, which is 42 000.

Plan F: The hundreds parts of the learner numbers

500	589	500	574	500	571	800	845	700	708	400	480
400	485	400	403	400	486	400	481	300	352	300	377
700	767	500	521	700	741	400	483	800	879	400	421
300	339	400	430	300	393	400	404	400	402	300	352
600	636	800	829	500	593	700	771	500	539	500	584
300	307	400	485	400	457	500	530	500	583	300	336
300	355	600	633	700	792	500	582	400	406	300	335
300	399	400	463	500	586	500	521	300	379	500	533
300	314	500	574	300	352	800	871	700	783	400	493
500	550	500	582	400	498	300	301	300	397	300	346
300	361	800	878	600	691	700	787	700	718	800	836
300	313	300	304	400	492	400	448	500	554	400	446
500	589	500	574	500	571	800	845	700	708	400	480

The numbers can be analysed like this:

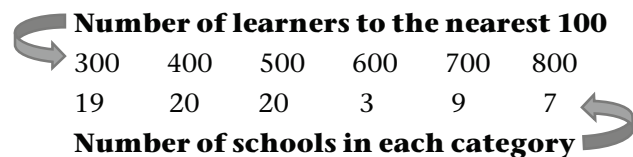

The above information can be used to estimate the total number of learners as:

$19 \times 300 + 20 \times 400 + 20 \times 500 + 3 \times 600 + 9 \times 700 + 7 \times 800$, which is 37 400.

Learner Book Overview		
Sections in this unit	Content	Pages in Learner Book
3.1 Rectangular prisms	A more in-depth look at prisms, in particular rectangular prisms	292 to 293
3.2 Nets of rectangular prisms	Making a rectangular prism from its net	293 to 295
3.3 Nets of other prisms	Making more prisms (e.g. triangular, pentagonal and hexagonal prisms) from their nets	296 to 297
3.4 Nets of a square-based pyramid	Making a square-based pyramid from its net	298
3.5 Nets of a cylinder and a cone	Making circular cylinders and circular cones from their nets	299 to 300

CAPS time allocation	5 hours
CAPS page references	22 and 198

Mathematical background

Paper models of any prism, cylinder, pyramid or cone can be made from single sheets of paper. The net of a 3-D object has all the flat surfaces (faces) and curved surfaces of the object laid out flat in such a way that they are all connected along at least one side/edge, or at least one point/vertex. This is because the surfaces of three-dimensional objects are two-dimensional.

This unit builds on the work done in Term 2 Unit 6 where four basic kinds of objects were investigated by folding, rolling or curling sheets of paper. The idea of the net of a three-dimensional object is mathematically important because the net includes *all* the faces or surfaces, something the folded, rolled or curled sheets of paper in the previous unit did not do.

Resources

Boxes that are rectangular prisms, including cubes – ask learners to bring small empty boxes from home (e.g. cereal boxes, tea boxes, biscuit boxes, facial cream boxes, etc.)

Scissors

Sheets of paper

Photocopies of nets (optional) and squared paper – provided in the Addendum on pages 413, 421 and 422

Large round objects such as plates or saucers, or a paper plate for each learner

Sticky tape and glue sticks

3.1 Rectangular prisms

Mathematical notes

Rectangular prisms have six rectangular faces. Opposite pairs of faces are exactly the same shape and size. If all six faces are squares, they will automatically be the same size. Such a prism is called a cube. Cubes are special rectangular prisms in three dimensions, in much the same way that squares are special rectangles in two dimensions.

Teaching guidelines

Question 3 is quite challenging. Bring to learners' attention that it is not stated that the object has six faces – it can have more, or fewer. Suggest to learners that if they find question 3 very challenging, it may help them if they first do question 4.

Possible misconceptions

Learners who did not believe that squares are special kinds of rectangles will probably also not believe that cubes are special rectangular prisms. This is not a serious issue. It is better that they doubt the truth of this than blindly take your word for it. At some point in the future they will suddenly realise that it is perfectly sensible. For now, just lodge the idea in their minds.

Answers

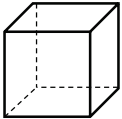
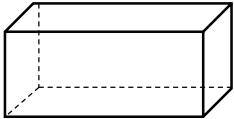
1. (a)  (b) 
2. (a) Yes, a rectangular prism has six faces.
(b) No, all the faces might not be rectangles.
3. (a) Yes, it is possible; but we are not told that the object has only six faces and that they are all rectangular, so we cannot be sure.
(b) Yes, it is possible; but we cannot be sure because some faces could have different quadrilateral shapes and we also do not know how many faces the object has.
(c) Yes, it is possible; but we do not know how many faces the object has and some or all of the other faces might be triangles or other polygons.
(d) Yes, it is possible; but we cannot be sure because even if the object has six faces, the other two faces might have other quadrilateral shapes.
4. (a) All of them because they all have more than one rectangular face; we are not told how many faces the object has or what the other faces look like.
(b) All of them because they all have at least two rectangular faces; we are not told how many faces the object has or what the other faces look like.

UNIT

3

PROPERTIES OF THREE-DIMENSIONAL OBJECTS

3.1 Rectangular prisms

Boxes with *six faces* that are all *rectangles* are called **rectangular prisms**.

The pairs of opposite faces are exactly the same shape and size.

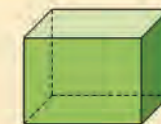

1. Draw the following rectangular prisms.
- (a) The object has six faces. All faces are squares.
- (b) The object has six faces.
Two opposite faces are squares.
All other faces are rectangles that are not squares.
2. Suppose you are told that a certain object has six faces.
- (a) Is it possible that the object is a rectangular prism?
(b) Can you be sure that it is actually a rectangular prism?
If you think you cannot be sure, explain why.
3. Answer the same two questions (2(a) and 2(b)) in each of the following cases.
- (a) All you know about the object is that it has rectangular faces.
(b) You only have information about two faces of the object, and what you know is that these two faces are rectangular.
(c) You only have information about three faces of the object, and what you know is that these three faces are rectangular.
(d) You only have information about four faces of the object, and what you know is that these four faces are rectangular.
4. (a) Which of the objects on the next page can be the object in 3(a)?
(b) Which of the objects on the next page can be the object in 3(b)?

If all six faces of a rectangular prism have exactly the same shape and size, the rectangular prism is called a **cube**.

292

UNIT 3: PROPERTIES OF THREE-DIMENSIONAL OBJECTS

Answers

4. (c) All of them because they all have at least three rectangular faces; we are not told how many faces the object has or what the other faces look like.
- (d) B, C and D because they all have at least four rectangular faces; we are not told how many faces the object has in total or what the other faces look like.

3.2 Nets of rectangular prisms

Mathematical notes

The net of a three-dimensional object has all of its faces (and curved surfaces, if applicable) laid out flat but connected in some way. It is important to be able to see which faces in a net are connected along their sides to form the edges in the 3-D object, and which faces may be opposite each other. Understanding how the net of the object relates to the object itself is very important in developing a fuller grasp of the spatial arrangement of the edges and faces of the object.

Teaching guidelines

Most boxes are rectangular prisms. Many of your learners have probably seen an “exploded” cardboard box that has been laid out flat. This is a good way to introduce the idea of a net. Allow your learners to investigate which faces are connected along their sides and which faces are opposite each other (each face is connected to four others and there are six faces in total, three pairs of faces that are identical and opposite each other).

Possible misconceptions

The spatial arrangement of the faces of a rectangular prism may be very challenging for young learners. If they struggle to “see” how the faces relate, especially with a cube where all six faces are identical squares, give them some cut-outs of nets. Let them fold the cut-outs into the prism and unfold them again to investigate which sides meet to form the edges and which faces are opposite each other.

Answers

1. (a) to (c) Practical work

- (c) Which of these objects can be the object in 3(c)?
- (d) Which of these objects can be the object in 3(d)?

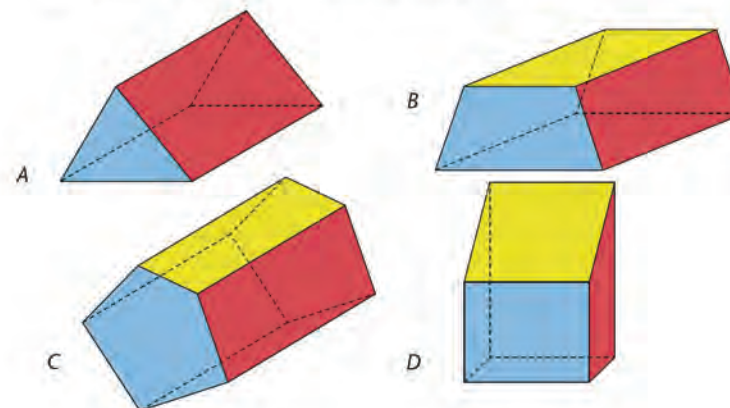

3.2 Nets of rectangular prisms

1. Use boxes that are rectangular prisms.
- (a) Make as few cuts as possible to open each box flat onto your table. All the faces of the box must still be attached. Cut off all the overlapping pieces.

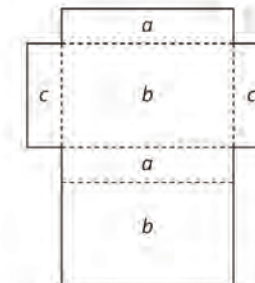

Net of a rectangular prism

The flat figure that shows all the faces of a 3-D object is called the **net** of the object.

- (b) Label the faces on the nets of your boxes to explain which faces are opposite each other when the net is folded into a prism. Write the same letter on the opposite faces.
- (c) Compare your nets with a classmate's nets. Draw two different ways to cut open a box to make a net. Use the same letters to label the faces that are opposite each other when the net is folded into a prism.

Teaching guidelines

Learners may find it challenging to interpret the drawings of Prisms A, B, C and D in question 2. You may help them by demonstrating the positions of the red faces on a box, for example a closed shoebox or an A4 paper box. To save time, you could photocopy the four nets provided on page 421 in the Addendum.

Learners who have real difficulties with question 3 may be given copies of the diagrams so that they can cut them out and fold them to check whether the figure is a net or not.

Answers

2. Practical work

3. (a) to (b) Practical work

(c) Diagram A will not form a cube – a cube has 6 faces.

Diagram B will not form a cube – the net will fold to an open-ended cube, i.e. a cube with an open face, because two faces will overlap.

2. (a) Draw four copies of this net on squared paper.

(b) Shade the faces on your nets that are shown in red on the prisms below. Let a be the face that is the base (it is at the bottom; it stays on the table).

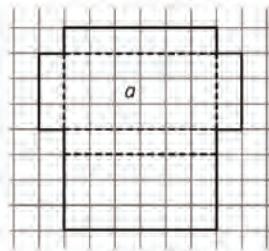

A



B

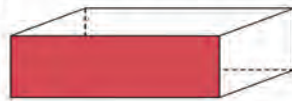

C



D

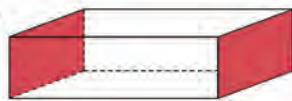

3. Work out which diagrams below are nets of a cube.

(a) Draw the diagrams on squared paper.

(b) Use the same letters to label the faces that are opposite each other when the net is folded into a cube.

(c) If a diagram is not the net of a cube, explain why this is so.

A



B

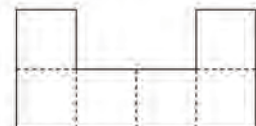

C

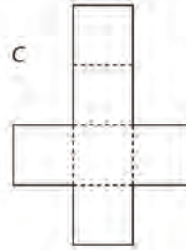

D

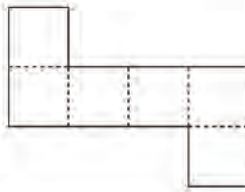

294 UNIT 3: PROPERTIES OF THREE-DIMENSIONAL OBJECTS

Teaching guidelines

Learners who are challenged by question 4 will probably benefit hugely if they shade one or two faces on the net that they have drawn, then cut it out and fold it to form a cube. They then check to which of the pictures their cube corresponds.

To save time, you could photocopy the six nets provided on page 422 in the Addendum.

Having a set of six cubes with their faces painted red and green, exactly as in the Learner Book, will be helpful too. Place the cubes on your table with labels (a) to (f) at them so that learners know which cube belongs to which sub-question. Invite them to look at the cubes to check their nets.

Answers

4. Examples:

(a)

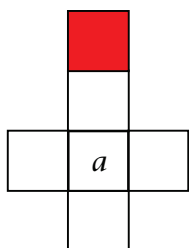

(b)

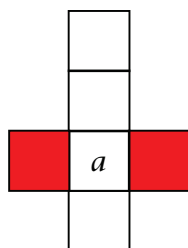

(c)

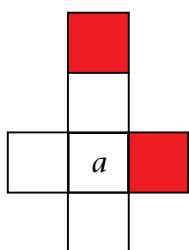

(d)

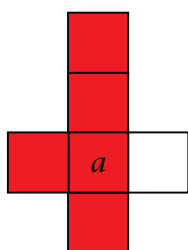

(e)

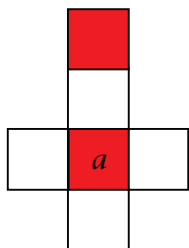

(f)

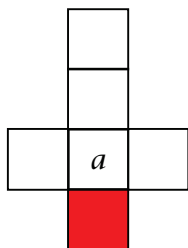

4. Draw the nets of the following cubes on squared paper. Shade the faces that are red on the cubes below. Let a be the face that is the base (it is at the bottom; it stays on the table).

(a)

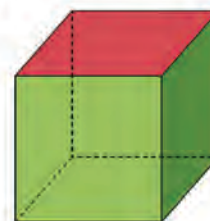

(b)

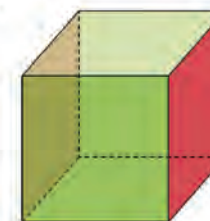

(c)

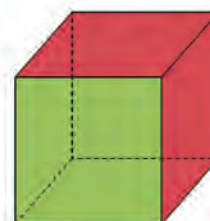

(d)

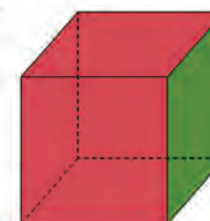

(e)

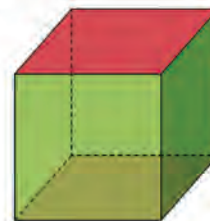

(f)

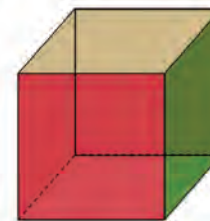

3.3 Nets of other prisms

Mathematical notes

All prisms have two polygonal faces opposite each other and rectangles for the remaining faces. For example, a pentagonal prism has two identical pentagons opposite each other and five rectangular faces connecting them.

Teaching guidelines

If learners are over-challenged, you may provide them with enlarged copies of the nets to cut out and fold. Encourage them to investigate how the sides come together. Many repetitions of folding and unfolding may be necessary before they begin to develop a “mental map” of the relationships.

Possible misconceptions

Insufficient experience viewing 3-D objects, and folding and unfolding their nets to see how the parts fit, will result in learners having a great deal of trouble identifying relationships between faces and edges.

Answers

1. (a) C (b) B
 (c) E (d) A

3.3 Nets of other prisms

The diagrams in questions 1(a) to (d) below show prisms. They are **prisms** because they have one pair of opposite faces that are exactly the same shape and size, and the other faces are all rectangles that are the same shape and size.

1. Match each prism with a net below.

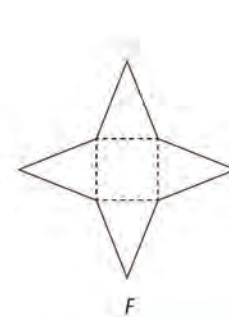
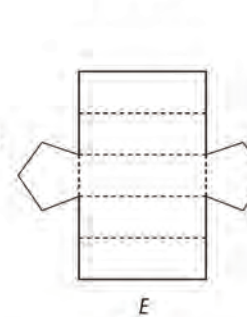
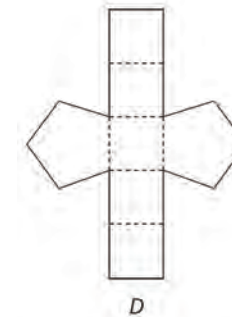
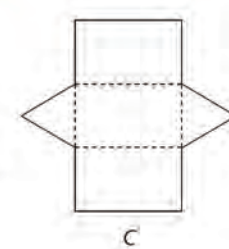
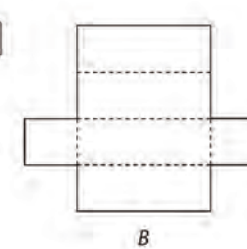
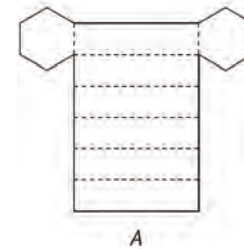
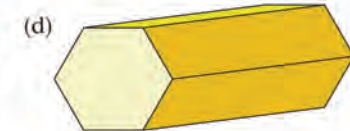
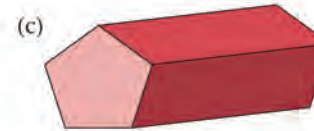

Teaching guidelines

When learners do question 2, alert them to the fact that they have to fold segments of the same width than the lengths of the sides on the bases. Instead of having learners trace the bases in the Learner Book, you may give them copies of the larger figures below.

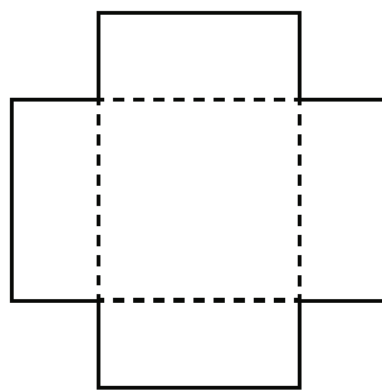
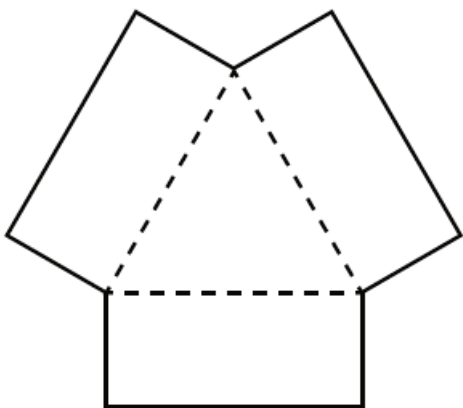
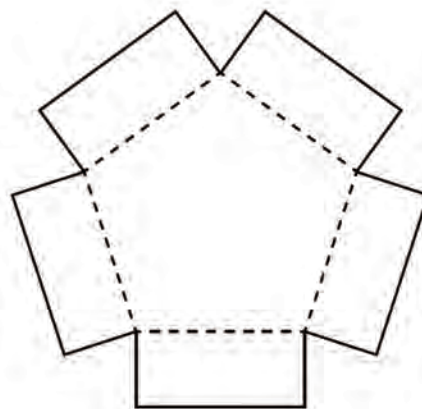
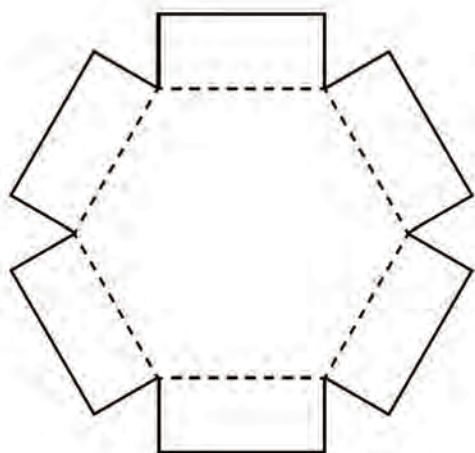

Answers

2. Practical work:

- (a) Triangular prism, using base D (b) Rectangular prism or cube, using base B
 (c) Pentagonal prism, using base C (d) Hexagonal prism, using base A

A quick way to make a paper prism

Step 1: Fold sections on a sheet of A4 paper, more or less as shown by the broken lines in the diagram on the right.

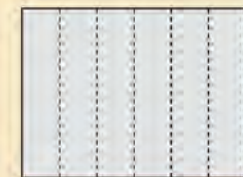

Step 2: Fold the sheet into a "tube" with five or six faces along its length.

Step 3: With a little extra work, you can now make a paper prism. You need to draw and cut out two bases so that they fit the openings.



2. Make four prisms using the bases below. You can follow the instructions above to make the "tube" of rectangular faces for each prism.

Trace the bases and cut them out. Use the flaps to stick the bases to the rectangular faces.

- (a) a prism with one pair of opposite faces that are triangles
 (b) a prism with one pair of opposite faces that are squares
 (c) a prism with one pair of opposite faces that are pentagons
 (d) a prism with one pair of opposite faces that are hexagons

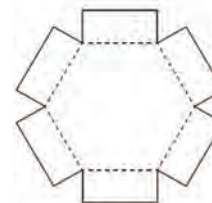

A

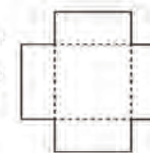

B

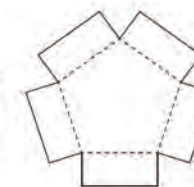

C

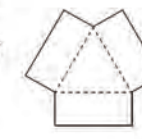

D

3.4 Nets of a square-based pyramid

Mathematical notes

Pyramids have a polygon as the base and a number of triangular faces that all come together at a common point.

Answers

- (a) 5 faces
(b) 4 triangles and 1 square
- (a) Diagram B. When the diagram (net) is folded on the dotted lines, the four triangular faces can meet at a common point to form the top (apex) of the pyramid. The bottom side/base of each triangular face will then meet up with one side of the square, which forms the base of the pyramid.
(b) There are a number of possibilities. Here are two examples:

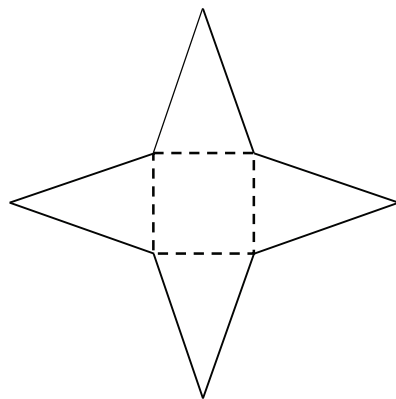
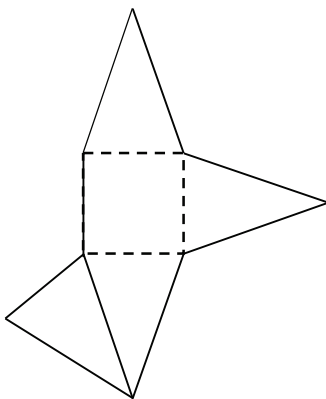

- (c) Consider and discuss learners' answers.

3.4 Nets of a square-based pyramid

- Look at the diagram of a square-based pyramid.
 - How many faces does a square-based pyramid have?
 - Describe the shapes of the faces.



- (a) Which of these diagrams is a net of a square-based pyramid? Explain your answer.

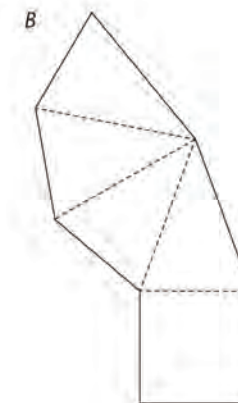
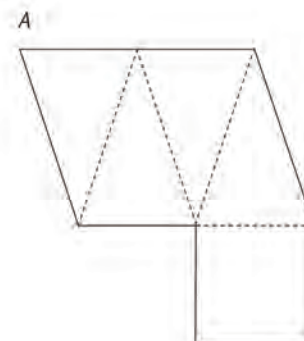

- Draw a different net that can be folded to make a square-based pyramid. Cut out your net and test if it works.
- Write to someone in another class. Explain how to make a net for a square-based pyramid. Make sure you say which sides of the polygons must have the same length.

3.5 Nets of a cylinder and a cone

Mathematical notes

We only deal with circular cylinders and circular cones.

The nets of cylinders have two circles (the two ends) and a rectangle (the curved surface).

The nets of cones have a circle (the base) and a large section of a circle that looks like a huge pizza slice, for example  (the curved surface).

Notes on questions

Note that in question 2, diagrams A, B and F will certainly not form cylinders. C, D and E may form cylinders, so long as the lengths of the quadrilaterals are equal to the length of the circumference of the circle.

Answers

1. Practical work
2. Nets of cylinders: C, D, E
Diagrams A, B and F will not form closed cylinders.

3.5 Nets of a cylinder and a cone

1. Use the tube of an empty toilet paper roll.
 - (a) Trace the circles on a sheet of paper.
 - (b) Cut open the tube along a straight line.
 - (c) Trace the shape of the cut tube on a sheet of paper.
 - (d) Cut out the three flat figures and use them to make a closed cylinder.



2. Which of the following diagrams are nets for a cylinder? Explain why the others will not make a cylinder.

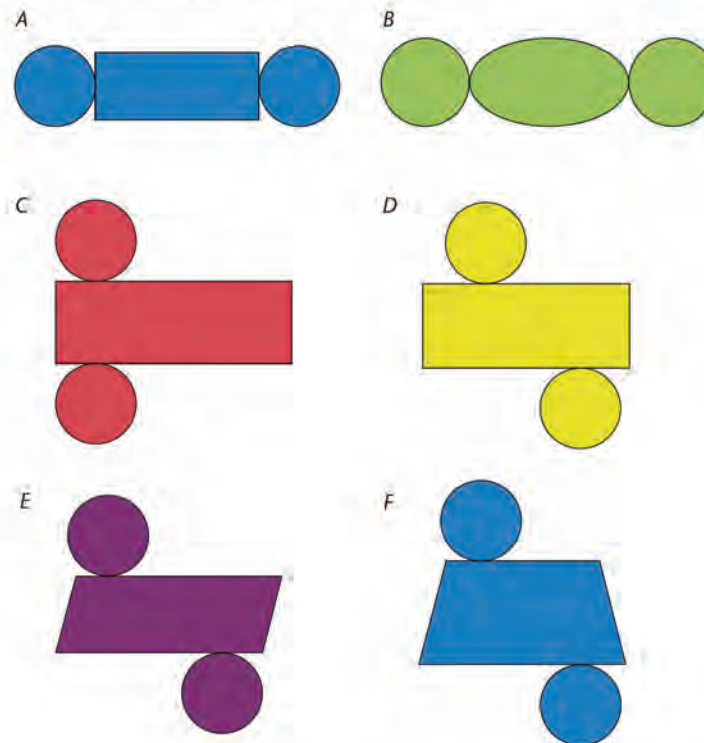

Notes on questions

In question 4 it should be obvious that diagram (a) cannot be a net for a cone (the base/circle is not connected correctly to the “pizza slice”). It may be fairly obvious to the eye that (c) and (d) will not form a closed cone. However, although (b) looks like it may form a cone, this can only happen if the edge of the base (circle) has the same length as the curved edge of the “pizza slice” (curved surface).

Answers

3. (a) to (e) Practical work
(f) One cone is tall and narrow; the other cone is less tall and has a wider/bigger base.
4. (a) No, the base must be connected to the circular edge.
(b) Yes, provided that the circumference of the full circle (base) is the same as the length of the curved side of the three-quarter circle.
(c) No, it will not form a closed cone; the circle (base) must be much smaller.
(d) No, the part of the net for the curved surface is wrong; the shape is wrong – it should, for instance, not have four straight sides.

3. Make cones.

- (a) Draw a circle by tracing around a round object, such as a plate or a saucer. (You can also use a round paper plate.)
(b) Find the centre of the circle by folding. Mark the centre.
(c) Cut out a wedge from the circle, as shown.
(d) Use both parts to make open cones.
(e) Trace the openings of the cones to make the circle bases for the cones.
(f) Describe the difference between the two completed cones.



4. Which of the diagrams below are nets for a cone? Explain why the others will not make cones.

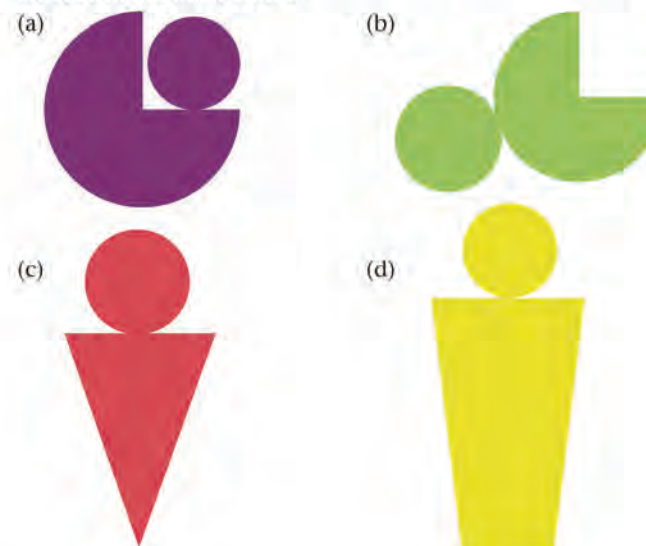

Learner Book Overview		
Sections in this unit	Content	Pages in Learner Book
4.1 Fractions of whole numbers	Finding fraction parts of collections and numbers	301 to 303
4.2 Fractions in diagrams	Fraction parts of shapes, and practice in stating equivalent fractions	304 to 305
4.3 Fractions on the number line	Fractions as numbers: representing fractions and mixed numbers on the number line	306
4.4 Solving problems	Using fractions in a variety of practical contexts	307 to 309

CAPS time allocation	5 hours
CAPS page references	16 and 199

Mathematical background

In Term 2 the focus was on dividing a *whole* into fraction parts, representing fractions with fraction strips, measuring length with fractions of a unit, equivalent fractions and representing fractions on the number line.

In Term 3 the focus was on consolidating understanding of equivalent fractions, and introducing addition and subtraction of fractions and mixed numbers.

In the current unit the idea of fractions of collections is extended to fractions of numbers. The unit also focuses on fraction parts of diagrams, specifically of circles in a way that will later support learners' understanding of angle measure.

Resources

Sheets of paper

Round objects (e.g. tins, cups, saucers, plastic or metal lids)

Scissors

4.1 Fractions of whole numbers

Teaching guidelines

Ask learners to look at the array of green cubes in the tinted passage and say what they perceive. Ask them to think how they may find the total number of cubes without counting them one by one. They may say they can see ten columns of five cubes, or five rows of ten cubes. You could write $10 + 10 + 10 + 10 + 10 = 50$ on the board, and then put questions like the following to the class:

- A. How much is one fifth of 50?
- B. How much is three fifths of 50?
- C. How much is five fifths of 50?

You may extend this to the following questions:

- D. How much is one tenth of 50?
- E. How much is three tenths of 50?
- F. How much is eight tenths of 50?

Notes on questions

Questions 1(b) and (e) have several equivalent fractions as answers.

Answers

1. (a) 30 beads (b) $\frac{6}{30}$ or $\frac{2}{10}$ or $\frac{1}{5}$ (c) $\frac{9}{30}$ or $\frac{3}{10}$
 (d) $\frac{3}{30}$ or $\frac{1}{10}$ (e) $\frac{12}{30}$ or $\frac{4}{10}$ or $\frac{2}{5}$
2. (a) 3 beads (b) 9 beads (c) 12 beads
 (d) 6 beads (e) 48 beads (f) 16 beads

UNIT

4

COMMON FRACTIONS

4.1 Fractions of whole numbers

$$50 \div 5 = 10$$

This means that $\frac{1}{5}$ of 50 is 10.



1. (a) How many beads are shown here, altogether?

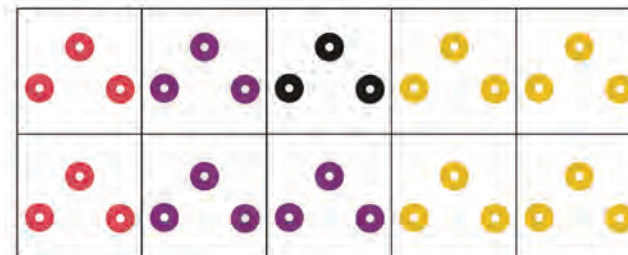

- (b) What fraction of all the beads is red?
 - (c) What fraction of all the beads is purple?
 - (d) What fraction of all the beads is black?
 - (e) What fraction of all the beads is yellow?
2. (a) How many beads do you have if you have $\frac{1}{10}$ of 30 beads?
 - (b) How many beads do you have if you have $\frac{3}{10}$ of 30 beads?
 - (c) How many beads do you have if you have $\frac{4}{10}$ of 30 beads?
 - (d) How many beads do you have if you have $\frac{2}{10}$ of 30 beads?
 - (e) How many beads do you have if you have $\frac{4}{10}$ of 120 beads?
 - (f) How many beads do you have if you have $\frac{2}{10}$ of 80 beads?

Notes on questions

Question 3 is about a situation similar to the one in the tinted passage on the previous page. The answer to question (b) is three times the answer to question (a).

Question (c) may trigger the idea of a half, and (d) the idea of a quarter. If learners use the trigger, the answer can very easily be found mentally. Otherwise they need to go back to question (a) to help them get the answer.

Answers

3. (a) 5 (b) 15
(c) 20 (d) 10
4. (a) $\frac{6}{18}$ or $\frac{1}{3}$
(b) Count all the triangles to find out how many make up the whole.
Count the number of triangles in the circle to see what part of the whole they make up.
(c) $\frac{1}{7}$ (There are 7 groups of 5 in the diagram.)
5. She baked 270 biscuits.
(One sixth is 45 biscuits, so the whole is $6 \times 45 = 270$ biscuits.)
6. He earned R4 200.
(One tenth is R420, so the whole is $10 \times R420 = R4\ 200$.)

3. (a) How many beads are $\frac{1}{8}$ of 40 beads?
(b) How many beads are $\frac{3}{8}$ of 40 beads?
(c) How many beads are $\frac{4}{8}$ of 40 beads?
(d) How many beads are $\frac{2}{8}$ of 40 beads?

4. Below are some collections of objects.

- (a) What fraction of the collection of triangles is in the circle?

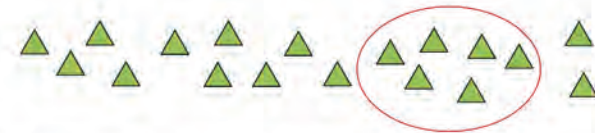

- (b) Write down the steps that you followed when you found the fraction of the triangles in (a).
(c) Here are biscuits that look like stars. What fraction of the number of biscuits is in the circle?



5. This is one sixth of the biscuits that Mama Themba made for the church function. How many biscuits did she bake?



6. R420 was stolen from Biza's bag. He said: "Someone stole exactly one tenth of the money I earned this month." How much money did Biza earn this month?

Teaching guidelines

Questions 7 to 9 are demanding because there are no contexts that may support learners' thinking. These questions are intended to promote more abstract thinking about fractions. However, learners should feel free to think of these questions as practical questions, for example to think of question 7(a) as asking: "How much is two fifths of R250?"

Go through the tinted passage with the class. There is an extra level of complexity here. You might like to write the question on the board. The first thing to ask is: "Is the answer going to be bigger or smaller than 16?" We have a whole number there (i.e. the 2), so it is going to be bigger than 16. The whole number gets multiplied by the whole number (i.e. 2×16), and then the fraction part is done.

Possible misconceptions

Learners might think that fraction questions *always* involve a smaller answer than the whole number given.

Notes on questions

You might like to discuss a few of the sub-questions in question 7 before letting the class work on their own. For example, in (a) somebody might suggest that you work out one fifth of 250 and then multiply the answer by 2. Somebody else might say you can multiply 2 by 250 and then divide by 5. If nobody suggests the second strategy, then don't teach it. Accept correct strategies, but don't teach them as formulas.

You might like to do question 9(a) with the class. Then they should work quickly and on their own, without writing down any steps.

Answers

7. (a) 100 (b) 66 (c) 450 (d) 455
(e) 840 (f) 8 638 (g) 360 (h) 1 200
8. (a) $250 + 100 = 350$ (b) $99 + 66 = 165$
(c) $1\ 440 + 450 = 1\ 890$ (d) $2\ 457 + 455 = 2\ 912$
(e) $1\ 440 + 840 = 2\ 280$ (f) $24\ 680 + 8\ 638 = 33\ 318$
(g) $1\ 680 + 360 = 2\ 040$ (h) $1\ 440 + 1\ 200 = 2\ 640$
9. (a) 12 (b) 21 (c) 26
(d) 55 (e) 170 (f) 69
10. Two thirds of a bar

7. Calculate:

- (a) $\frac{2}{5}$ of 250 (b) $\frac{2}{3}$ of 99
(c) $\frac{5}{8}$ of 720 (d) $\frac{5}{9}$ of 819
(e) $\frac{7}{12}$ of 1 440 (f) $\frac{7}{10}$ of 12 340
(g) $\frac{3}{7}$ of 840 (h) $\frac{5}{6}$ of 1 440

Nick has to calculate $2\frac{5}{8}$ of 16. He thinks like this:

$2\frac{5}{8}$ means $2 + \frac{5}{8}$. So $2\frac{5}{8}$ of 16 means two 16s plus $\frac{5}{8}$ of 16.

That is 32 plus 10, which is 42.

8. Use your answers in question 7 and calculate:

- (a) $1\frac{2}{5}$ of 250 (b) $1\frac{2}{3}$ of 99
(c) $2\frac{5}{8}$ of 720 (d) $3\frac{5}{9}$ of 819
(e) $1\frac{7}{12}$ of 1 440 (f) $2\frac{7}{10}$ of 12 340
(g) $2\frac{3}{7}$ of 840 (h) $1\frac{5}{6}$ of 1 440

9. You should be able to do the following mentally. This means you should be able to write down the final answer straight away without writing down anything else.

- (a) $1\frac{1}{2}$ of 8 (b) $2\frac{1}{3}$ of 9
(c) $2\frac{1}{6}$ of 12 (d) $2\frac{3}{4}$ of 20
(e) $3\frac{2}{5}$ of 50 (f) $2\frac{3}{10}$ of 30

10. Three friends share two chocolate bars equally. How much chocolate does each one get?

4.2 Fractions in diagrams

Teaching guidelines

Partitioning a circle into fraction parts is not only a way to consolidate the fraction concept and equivalent fractions; it also lays a basis for the introduction of angle measurement in Grade 6.

To save time, you can photocopy the four circles provided in the Addendum on page 423.

Answers

1. See the next page in the Learner Book for the questions.

(a)



(b)

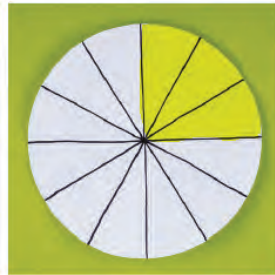

(c)



(d)

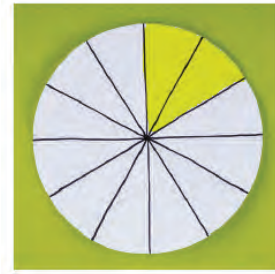

4.2 Fractions in diagrams

1. Follow the instructions below and make *four* circles:



Step 1: Trace around a round object to draw a circle.



Step 2: Cut out the circle.



Step 3: Fold it in half.



Step 4: Fold it in half again. You now have four quarters.

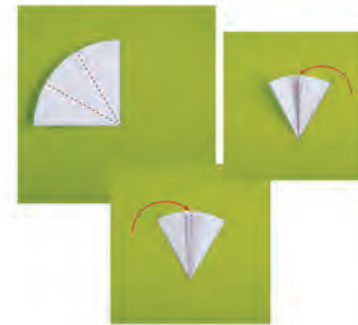

Step 5: Fold the two sides over so that the two folded parts are exactly the same size.

Step 6: Unfold and draw clear lines on the folds.



Teaching guidelines

First listen to learners' explanations in question 2(c) before you refer them to the definition given in the Learner Book. Do NOT ask for a definition in a test or exam! If the learners can work with equivalent fractions and recognise them, that is sufficient.

When learners have finished question 3, ask them if they can work out why (c) and (d) have the same answer. They might be able to see (visualise) that the figures have the same shape but different orientations.

Answers

- The solutions for (a), (b), (c) and (d) are on the previous page.
- They have the same value. (They have the same size.)
 - They have the same value. (They have the same size.)
 - They are fractions with the same value (the same size), but different names.
- $\frac{10}{24}$ or $\frac{5}{12}$ (b) $\frac{8}{24}$ or $\frac{2}{6}$ or $\frac{1}{3}$
 - $\frac{6}{24}$ or $\frac{3}{12}$ or $\frac{1}{4}$ (d) $\frac{6}{24}$ or $\frac{3}{12}$ or $\frac{1}{4}$

- Shade one quarter of your first circle.
 - Shade three twelfths of your second circle.
 - Shade two twelfths of your third circle.
 - Shade one sixth of your fourth circle.
- What do you notice about one quarter and three twelfths?
 - What do you notice about one sixth and two twelfths?
 - Write what you understand by *equivalent* fractions.

Equivalent fractions are fractions with different names but with the same value.

- What fraction of the whole figure is shaded in each case? If possible, write the fraction in more than one way.

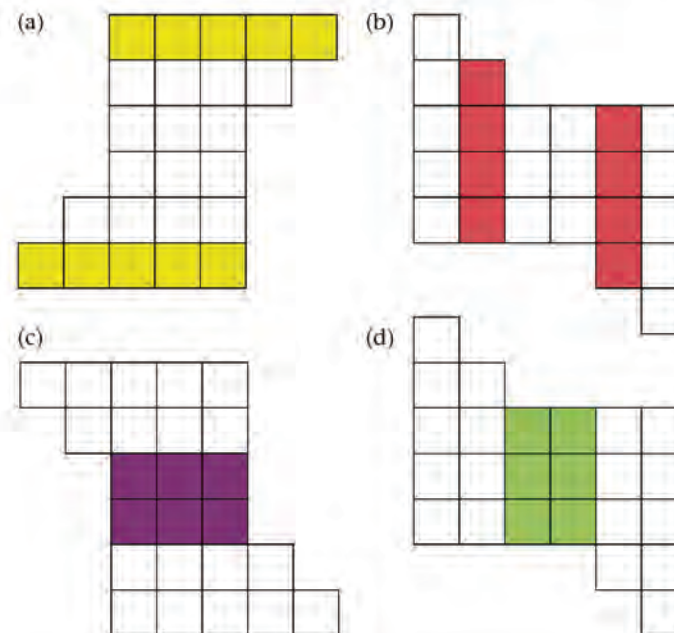

4.3 Fractions on the number line

Teaching guidelines

Learners are already familiar with fractions on number lines. Here they are challenged to see that they are dealing with eighths (first number line), twelfths (second number line), and tenths (third number line), and then with twelfths on a slightly smaller scale (fourth number line). To save time, you can photocopy the number lines on page 424 of the Addendum.

This is an opportunity for learners to explore equivalent fractions on a variety of number lines. You might like to draw the number lines on the board and get learners to offer their answers. Look at the third number line below. You will see that here is a chance to show that $2\frac{5}{10} = 2\frac{4}{8}$. There are more possibilities than the answers given for question 2 below.

Answers

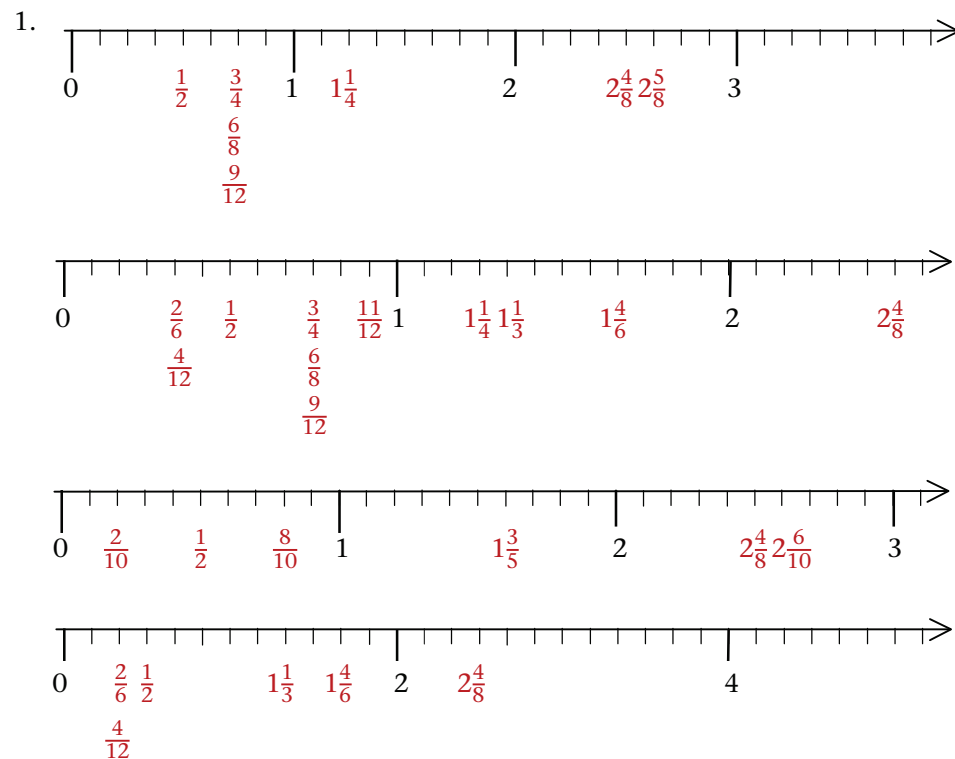

2. $\frac{3}{4} = \frac{6}{8} = \frac{9}{12}$ and $\frac{2}{6} = \frac{4}{12}$; also $1\frac{1}{4} = 1\frac{2}{8}$, $2\frac{5}{10} = 2\frac{4}{8}$, etc. (See “Teaching guidelines” above.)

4.3 Fractions on the number line

1. Copy the four number lines below and write the following fractions at the correct places on the number lines. Note that it is sometimes possible to place more than one fraction in a certain position. Some fractions can also be put on more than one of the number lines. Try to find those fractions and do it.

- | | | | |
|---------------------|--------------------|--------------------|---------------------|
| (a) $\frac{1}{2}$ | (b) $\frac{3}{4}$ | (c) $\frac{8}{10}$ | (d) $\frac{11}{12}$ |
| (e) $1\frac{3}{5}$ | (f) $\frac{2}{6}$ | (g) $\frac{4}{12}$ | (h) $\frac{6}{8}$ |
| (i) $2\frac{6}{10}$ | (j) $1\frac{1}{3}$ | (k) $\frac{2}{10}$ | (l) $2\frac{5}{8}$ |
| (m) $\frac{9}{12}$ | (n) $1\frac{1}{4}$ | (o) $1\frac{4}{6}$ | (p) $2\frac{4}{8}$ |

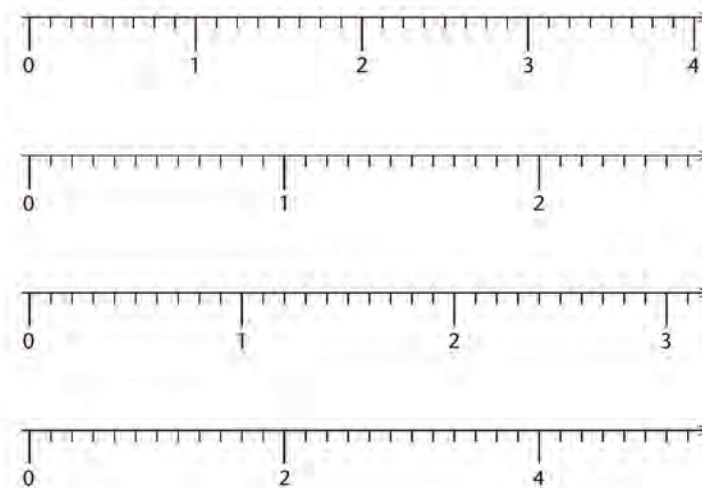

2. Make a list of all the equivalent fractions that you found in question 1.

4.4 Solving problems

Teaching guidelines

This is a consolidation exercise. Rather than doing any teaching to the whole class, circulate among learners and provide support where needed.

Answers

- $\frac{2}{9}$
 - $\frac{4}{9}$
 - $\frac{1}{9}$
 - $\frac{2}{9}$
 - $\frac{1}{9}$
 - $\frac{1}{10}$
 - $4\frac{7}{10}$
 - $2\frac{4}{7}$
- $\frac{4}{10}$
- 20 thirds = $6\frac{2}{3}$ slabs of chocolate
 - $20 \times \frac{2}{5} = \frac{40}{5} = 8$ bottles of juice
- $\frac{1}{5}$ of 100 cm = 20 cm $\rightarrow \frac{3}{5}$ of 100 cm = 3×20 cm = 60 cm
 - 30 cm
 - 25 mm
 - $\frac{6}{8} = \frac{3}{4} \rightarrow \frac{3}{4}$ of 1 000 m = 750 m
 - $\frac{1}{10}$ of 1 000 g = 100 g $\rightarrow \frac{6}{10}$ of 1 000 g = 600 g
 - $\frac{1}{5}$ of 1 000 g = 200 g $\rightarrow \frac{3}{5}$ of 1 000 g = 600 g
 - $\frac{1}{8}$ of 1 000 g = 125 g $\rightarrow \frac{3}{8}$ of 1 000 g = 375 g
 - $\frac{3}{4}$ of 1 000 g = 750 g

4.4 Solving problems

- 
 - What part of the strip is green?
 - What part of the strip is red?
 - What part of the strip is white?
 - What part of the strip is yellow?
 - What is $1 - \frac{8}{9}$?
 - What is $1 - \frac{9}{10}$?
 - What is $5 - \frac{3}{10}$?
 - What is $3 - \frac{3}{7}$?
- A cake is cut into ten equal slices. Katie eats 2 slices, Farida eats 1 slice and Busile eats 3 slices. What fraction of the whole cake is left over?
- Each child at a party eats one third of a slab of chocolate. Each child drinks two fifths of a large bottle of juice. If there are 20 children at the party,
 - how much chocolate do they eat?
 - how much juice do they drink?
- How many centimetres are in three-fifths of a metre?
 - How many centimetres are in three-tenths of a metre?
 - How many millimetres are in two and a half centimetres?
 - How many metres are there in six-eighths of a kilometre?
 - How many grams are in six-tenths of a kilogram?
 - How many grams are in three-fifths of a kilogram?
 - How many grams are in three-eighths of a kilogram?
 - How many grams are in three-quarters of a kilogram?

Answers

4. (i) 400 ml
(j) 750 ml
(k) $\frac{1}{8}$ of 1 000 ml = 125 ml \rightarrow $\frac{3}{8}$ of 1 000 ml = 375 ml

Notes on questions

Question 5 is a simple revision of earlier fractions, with opportunities for spotting equivalent fractions. You might like to ask *how much bread* (how many loaves) is ten tenths, which is the answer to question 5(i). Some learners may have forgotten that there were 12 loaves to start with. You could go on to ask *how much bread* was given in each of the questions (a) to (h), or give this as homework.

Ask learners how they worked out their answers to question 6. They may indicate that they started by saying $8 \times 4 = 32$ loaves, and then worked out the fraction. Accept any reasonable method.

Answers

5. (a) $\frac{1}{10}$ (b) $\frac{2}{10}$ or $\frac{1}{5}$ (c) $\frac{3}{10}$
(d) $\frac{4}{10}$ or $\frac{2}{5}$ (e) $\frac{5}{10}$ or $\frac{1}{2}$ (f) $\frac{6}{10}$ or $\frac{3}{5}$
(g) $\frac{8}{10}$ or $\frac{4}{5}$ (h) $\frac{9}{10}$ (i) $\frac{10}{10}$ (all of the bread)
6. $\frac{34}{8} = 4\frac{2}{8} = 4\frac{1}{4}$ loaves (See the note regarding question 6 above.)
7. (a) $\frac{1}{8}$
(b) One eighth = R75. Nick will get R75.
Three eighths = $R75 \times 3 = R225$. Faaiez will get R225.
One half of R600 = R300. Thandeka will get R300.

- (i) How many millilitres are in two-fifths of a litre?
(j) How many millilitres are in three-quarters of a litre?
(k) How many millilitres are in three-eighths of a litre?
5. There are ten children at a camp and 12 loaves of bread are shared equally between them.
- (a) What fraction of all the bread does each child get?
(b) What fraction of all the bread do two of these children together get?
(c) What fraction of all the bread do three of these children together get?
(d) What fraction of all the bread do four of these children together get?
(e) What fraction of all the bread do five of these children together get?
(f) What fraction of all the bread do six of these children together get?
(g) What fraction of all the bread do eight of these children together get?
(h) What fraction of all the bread do nine of these children together get?
(i) What fraction of all the bread do ten of these children together get?
6. 34 loaves of bread are shared equally among 8 families. How much bread does each family get?
7. Nick, Faaiez and Thandeka worked on a project. Not everyone did the same amount of work. They decided that if they win the prize, they will share it in the following way:
Thandeka will get half of the money. Faaiez will get three-eighths of the money. Nick will get the rest.
- (a) What fraction of the money will Nick get?
(b) How much money will each of them get if the prize is R600?

Notes on questions

Question 8 is an opportunity for finding equivalent fractions.

Answers

8. (a) $\frac{1}{12}$ (b) $\frac{2}{12}$ or $\frac{1}{6}$
(c) $\frac{3}{12}$ or $\frac{1}{4}$ (d) $\frac{4}{12}$ or $\frac{1}{3}$
(e) $\frac{6}{12}$ or $\frac{1}{2}$
9. (a) Juliet coloured one of the six columns in the diagram, so she coloured one sixth of the diagram. In doing so, she coloured two of the twelve blocks in the diagram. So, she also coloured two twelfths of the diagram.
It is very easy to see the equivalent fractions in the diagram: two brown blocks *look like* one sixth.
- (b) 3 small blocks: three twelfths; one quarter
4 small blocks: four twelfths; two sixths; one third
6 small blocks: six twelfths; three sixths; two quarters; one half
- (c) $\frac{10}{12}$ or $\frac{5}{6}$ (Some learners may already state the equivalent fraction before doing (d).)
(d) $\frac{10}{12}$ or $\frac{5}{6}$
(e) $\frac{5}{12}$
(f) $\frac{8}{12}$ or $\frac{2}{3}$

8. A chocolate slab is divided into 12 small blocks.
- (a) What fraction of the whole slab is 1 small block?
(b) What fraction of the whole slab is 2 small blocks?
(c) What fraction of the whole slab is 3 small blocks?
(d) What fraction of the whole slab is 4 small blocks?
(e) What fraction of the whole slab is 6 small blocks?
9. Juliet draws the chocolate slab in question 8 in two different ways:



- (a) She says: "In question 8(b) I wrote that two small blocks are two twelfths of the whole slab. If I colour the first column in my second drawing I can see that two blocks can also be one sixth of the whole slab."



Can you explain Juliet's thinking?

- (b) Look at the two drawings of the slab and find more than one way to write 3, 4 and 6 small blocks as a fraction of the whole slab.
(c) What fraction of the whole slab is 10 small blocks?
(d) Can you write that fraction in a different way?
(e) What fraction of the whole slab is 5 small blocks?
(f) What fraction of the whole slab is 8 small blocks?

Learner Book Overview		
Sections in this unit	Content	Pages in Learner Book
5.1 Revision practice	Grouping and sharing problems	310
5.2 Making pictures smaller and bigger	Division in enlargement and reduction situations	311
5.3 Ratios of enlargement and reduction	Refining the concepts of ratio, enlargement and reduction	312 to 314
5.4 Ratio again	An investigation involving ratios between rates	315 to 317

CAPS time allocation	7 hours
CAPS page references	13 to 15 and 200 to 201

In Term 2 Unit 9 the focus for division was on grouping and sharing problems, i.e. situations in which a quantity is divided into equal parts.

In this unit the focus is on the use of division to solve problems which involve a constant **ratio** between two quantities.

Mathematical background

Constant ratios between two quantities appear in different kinds of situations, for example:

- Enlargement and reduction (e.g. of photographs) and scale drawings (see Sections 5.2 and 5.3). The ratio of enlargement or reduction is also called the **scale factor**. The term “scale factor” is normally used with respect to maps.
- Implementation of recipes. For example, a recipe may specify 3 cups of flour, 2 cups of sugar and 5 ml salt. How many cups of sugar and how much salt should you mix with 6 cups of flour? The term “proportion” is often used with reference to recipes.
- Comparison of rates (see Term 2 Unit 5, Section 5.6 as well as Section 5.4 of this unit).
- Proportions in designs.

5.1 Revision practice

Notes on questions

Questions 1, 3, 4, 5 and 10 are **grouping** problems. Learners have to determine how many groups of a given size can be formed from a given total.

Questions 2, 6 and 8 are **sharing** problems. Learners have to determine how big each of a given number of equal shares is.

Question 9 is a **ratio** situation.

Teaching guidelines

One of the biggest teaching challenges in Mathematics is to empower learners to effectively read and interpret word problems and decide correctly what calculations to do to solve a given problem. The development of this capacity is often undermined by the availability of clues, external to the question itself, which helps the learner to identify the correct operation without having to engage with the problem description.

When learners read page 310 of the Learner Book, the unit title already tells them that the questions require division. Some learners may then simply divide the bigger number by the smaller number in each of the questions without actually reading the questions. In this way they may get all the answers right except for 9(a), without applying their minds to the questions at all!

To reduce the chances that this will happen, you may instruct learners at the beginning to write a short sentence or paragraph for each question, explaining why they believe the calculations they plan to do will provide the answer to the question. Alternatively, they may make a quick freehand sketch to represent the situation and the solution they provide.

Answers

1. Thivha can fill 25 egg boxes and 8 eggs are left over.
2. $R416 \div 32 = R13$
3. 32 bags (13 guavas left over)
4. $342 \div 48 = 7 \text{ rem } 6 \rightarrow 8 \text{ buses}$
5. 18 shoelaces
6. (a) 21 toffees (b) 5 toffees
7. (a) 33 rem 11 (b) 16 rem 40 (c) 29 rem 17
(d) 24 rem 21 (e) 11 rem 13 (f) 22 rem 13
8. 25 kg
9. (a) 80 kg (b) 5 kg
10. 12 boxes

UNIT

5

WHOLE NUMBERS:

DIVISION

5.1 Revision practice

1. Thivha's hens laid 908 eggs. Thivha packs the eggs into egg boxes that take 36 eggs each. How many egg boxes can Thivha fill? How many eggs are left over?
2. 32 boxes of fruit juice cost R416 in total. How much does one box cost?
3. The fruit seller fills bags with guavas. How many bags can he fill with 16 guavas each, if he picked 525 guavas from his orchard?
4. How many buses are needed to transport 342 learners to an athletics meeting if 48 learners may travel in one bus?
5. If the length of one shoelace is 46 cm, how many shoelaces can be cut from 830 cm shoelace string?
6. Daniel has to divide 488 toffees equally into 23 packets.
(a) How many toffees will go into each packet?
(b) How many toffees will be left over?
7. Calculate.
(a) $902 \div 27$ (b) $792 \div 47$
(c) $539 \div 18$ (d) $837 \div 34$
(e) $937 \div 84$ (f) $937 \div 42$
8. The mass of 13 same-sized bags of dog food is 325 kg. What is the mass of one bag of dog food?
9. (a) If an elephant eats 40 times as much as a goat in one day, how much does the elephant eat when the goat eats 2 kg of food?
(b) If an elephant eats 40 times as much as a goat in one day, how much does the goat eat when the elephant eats 200 kg of food?
10. A hotel needs 270 new dinner plates. The plates are sold in boxes of 24 plates each. How many boxes should the hotel buy?

310

UNIT 5: WHOLE NUMBERS: DIVISION

5.2 Making pictures smaller and bigger

Teaching guidelines

There are three quantities involved in a simple ratio situation, as demonstrated in the following table of measurements for the two pictures described in question 1:

x = measurement on big picture	30	120	192
y = measurement on small picture	5	20	32
$x \div y$	6	6	6

The measurement on the big picture or object, and the measurement on the small picture or object, are variable quantities. The one measurement divided by the other (corresponding) measurement is a constant; it is called the **ratio** between the two variables.

At least three kinds of questions can be asked about ratio situations:

- The measurement on the **bigger object is given**, as well as the (big to small) ratio, and the corresponding measurement on the smaller object needs to be found, for example questions 1(b) and (c), and 2(b) and (c). This requires division by the ratio/scale factor.
- The measurement on the **smaller object is given**, as well as the (small to big) ratio, and the corresponding measurement on the bigger object needs to be found, for example questions 1(a) and 2(a). This requires multiplication by the ratio/scale factor.
- Some **corresponding measurements on both objects are given**, and the question requests calculation of the ratio. No question of this kind is included in this unit.

Possible misconceptions

Learners may interpret a constant ratio situation as a constant difference situation. For example, in question 2(a) they may give $8 + 60 = 68$ as the answer.

Answers

- (a) 30 mm (b) 20 mm (c) 32 mm
- (a) 480 mm (b) 30 mm (c) 36 mm

5.2 Making pictures smaller and bigger



Picture 1



Picture 2

Look closely at the two pictures above. Picture 2 is exactly the same as Picture 1, only much larger. All the parts have been drawn bigger in exactly the same way.

- A picture of another house is drawn bigger, so that it is 6 times as big.
 - If a window is 5 mm high in the small picture, how high is it in the big picture?
 - If a door is 120 mm high in the big picture, how high is it in the small picture?
 - If the house is 192 mm high in the big picture, how high is it in the small picture?
- A house is 60 times as big as the drawings on the plan of the house.
 - If a window is 8 mm high on the plan, how high is the window in the actual house?
 - A door of the actual house is 1 800 mm high. How high is the door on the plan?
 - A wall of the actual house is 2 160 mm high. How high is the wall on the plan?

5.3 Ratios of enlargement and reduction

Teaching guidelines

The purpose of questions 1 to 5 is to further develop learners' understanding of ratio in the context of enlargement and reduction. Pictures A, B and C differ in size only, unlike Pictures D and F on page 314 of the Learner Book, which differ in a different way: Picture F is compressed across the width compared to Picture D.

Answers

1. Yes
2. It is the same picture, but not the same size.
3. 40 mm high and 60 mm wide
4. Yes, it is.
5. Picture A: 90 mm
Picture B: 72 mm
Picture C: 54 mm

5.3 Ratios of enlargement and reduction

Three pictures of a bird are shown below.

1. Is it the same bird in the three pictures?
2. Are the pictures the same? If not, in what way do they differ?



Picture A



Picture B



Picture C

Picture A is 50 mm high and 75 mm wide.

3. How high is Picture B, and how wide is it?
4. Check whether Picture C is 30 mm high and 45 mm wide.
5. Measure the lengths of the red lines that have been drawn on the three pictures.

Picture A is an **enlargement** of Picture B. All the parts are made bigger in exactly the same way. To “enlarge” means to make bigger.

Picture C is a **reduction** of Picture B. To “reduce” means to make smaller.

Possible misconceptions

Enlargement and reduction which involve the same ratio in all directions (as demonstrated by Figures X and Z in question 10) should be distinguished from compression and stretching in one direction only (as demonstrated by the relations between Figures Y and Z, or between Figures X and Y).

Questions 9 and 10 are intended as vehicles to clarify this issue in class.

Answers

6. Learners check and correct their work in questions 3 and 5 if necessary.
7. (a) 90 mm high and 135 mm wide (b) 162 mm
8. (a) 30 mm (b) 36 mm
9. No
10. Figure Z

6. Now check whether the measurements for Pictures A, B and C in this table agree with the measurements you made.

	Picture A	Picture B	Picture C
Height in mm	50	40	30
Width in mm	75	60	45
Length of red line in mm	90	72	54

7. Picture D is an enlargement of Picture C, and it is three times as big as Picture C. Picture D is not shown here.
 - (a) How high and how wide do you think Picture D is?
 - (b) How long do you think the red line on Picture D is?
8. Picture E is a reduction of Picture B. Picture E is 20 mm high. Picture E is also not shown here.
 - (a) What do you think is the width of Picture E?
 - (b) What do you think the length of the red line on Picture E is?
9. Is Picture F on the next page an enlargement of Picture E?
10. Which of Figures Y and Z below is a true reduction of Figure X? Remember that in a reduction all the parts are smaller in exactly the same way.

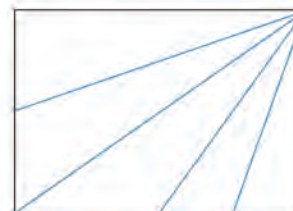

Figure X



Figure Y

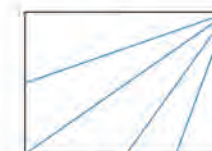

Figure Z

Answers

11. Learners measure and correct their work in questions 7 and 8 if necessary.

Additional learning activity (See Addendum page 425)

Which of the rectangles below are enlargements or reductions of the shaded rectangle?

In each case, explain why you think it is, or why it is not.

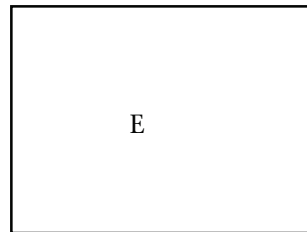
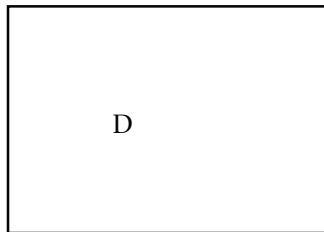
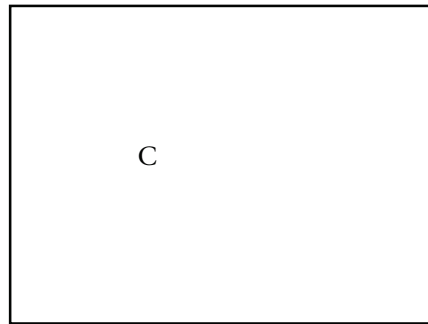
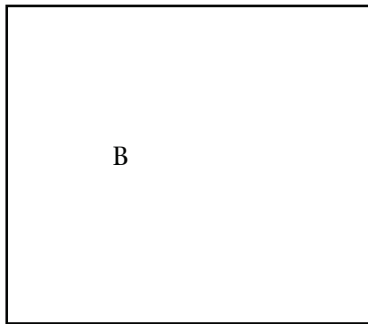
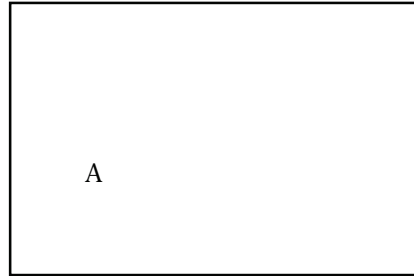

11. Take the measurements of Pictures D and E to check your answers for questions 7 and 8.



Picture D



Picture E



Picture F

5.4 Ratio again

Teaching guidelines

This section comprises an extended investigation that can be given as a **project**. Encourage learners to make drawings to support their reasoning about the questions.

Make sure that learners understand at the outset what is meant by “to keep up with his mother”.

Answers

- 40
- (a) 60 (b) 200
- (a) 10 (b) 25

5.4 Ratio again



To keep up with his mother, baby ostrich Jasper has to take 20 steps for every one step his mother takes.

- How many steps must Jasper take while his mother takes two steps, if he wants to keep up with her?
- How many steps must Jasper take in each case below, to keep up?
 - While his mother takes 3 steps
 - While his mother takes 10 steps

The young ostrich Lenka, on the left in the picture, has to take 5 steps to keep up with the mother while she takes 3 steps.

- How many steps must Lenka take in each case below?
 - While the mother takes 6 steps
 - While the mother takes 15 steps

Teaching guidelines

Question 6 is tough, since the ratio between Lenka's step length and Jasper's step length is not known at this stage. To be able to produce the answer to the question, learners will have to think of using the mother ostrich's step as an **intermediary** between Jasper and Lenka:

$$\begin{aligned} 15 \text{ steps by Lenka} &= 9 \text{ steps by the mother} \\ &= 9 \times 20 \text{ steps by Jasper} \\ &= 180 \text{ steps by Jasper} \end{aligned}$$

This is a challenge that goes beyond the requirements of the Grade 5 curriculum. Learners can gain little by being shown how to get the answer, but their mental development can benefit from trying again after doing questions 7(a), (b) and (c), or if they do not manage then, trying again after doing questions 8 to 11. Please allow them to develop their own plan.

Answers

4.

Number of steps by the mother	1	2	3	6	9	15	30	48
Number of steps by Jasper	20	40	60	120	180	300	600	960

5.

Number of steps by the mother	3	6	9	15	30	48
Number of steps by Lenka	5	10	15	25	50	80

6. 180

4. Copy this table. Then complete it to show how many steps Jasper has to take while his mother takes 1, 2, 3, 6, 9, 15, 30 and 48 steps. You will have to do some calculations.

Number of steps by the mother	1	2	3	6	9	15	30	48
Number of steps by Jasper								

5. Copy this table. Then complete it to show how many steps Lenka has to take while the mother takes 3, 6, 9, 15, 30 and 48 steps. You will have to do some calculations.

Number of steps by the mother	3	6	9	15	30	48
Number of steps by Lenka						

To describe how Lenka's numbers of steps compare to the mother's numbers of steps when they walk together, we may say the following:

Lenka takes 5 steps for every 3 steps the mother takes.
We may also say:
Lenka's number of steps and the mother's number of steps are **in the ratio 5 to 3.**

Here is another way of saying this:

The ratio between Lenka's number of steps and the mother's number of steps is 5 to 3.

The ratio between the mother's number of steps and Lenka's number of steps is 3 to 5. (Notice that the numbers are the other way round now.)

6. How many steps must Jasper take when Lenka takes 15 steps, to keep up?
(You may skip this question now if you wish, and try to do it later.)

Answers

7. (a) 50 (b) 600 (c) 600 (d) 180
8. (a) 14 (b) 27
9. (a) 120 (b) 210
10. (a) 60 (b) 720
11. (a) 5 (b) 25
12. 180

Teaching guidelines

If learners still do not get question 6 right when they do question 12, you may suggest that they complete the following table by combining the tables they completed in questions 4 and 5.

Number of steps by the mother	3	6	9	15	30	48
Number of steps by Jasper						
Number of steps by Lenka						

7. (a) How many steps must Lenka take when the mother takes 30 steps, to keep up?
(b) How many steps must Jasper take when his mother takes 30 steps?
(c) How many steps must Jasper take when Lenka takes 50 steps?
(d) How many steps must Jasper take when Lenka takes 15 steps? (You may skip this question again if you wish, and try to do it later.)
8. (a) One day Jasper had to take 280 steps to keep up with his mother. How many steps did she take?
(b) On another day Jasper had to take 540 steps to keep up with his mother. How many steps did she take?
9. (a) One day Lenka had to take 200 steps to keep up with the mother. How many steps did the mother take?
(b) One day Lenka had to take 350 steps to keep up with the mother. How many steps did the mother take?
10. (a) How many steps must Jasper take for five steps that Lenka takes, to keep up with her and the mother?
(b) How many steps must Jasper take for 60 steps that Lenka takes, to keep up with her and the mother?
11. (a) How many steps must Lenka take for 60 steps that Jasper takes, to keep up with him and his mother?
(b) How many steps must Lenka take for 300 steps that Jasper takes, to keep up with him and his mother?
12. If you have not answered question 6 yet, try to answer it now.

Grade 5 Term 4 Unit 6 Perimeter, area and volume

Learner Book Overview		
Sections in this unit	Content	Pages in Learner Book
	Exploring the differences between perimeter, area and volume	318
6.1 Perimeter	The concept of perimeter: the distance around the outer edge of an object; perimeter is measured in units of length	319 to 322
6.2 Area	The concept of area as the number of squares needed to cover a surface	323 to 326
6.3 Volume and capacity	The concept of volume as the number of cubes that occupy the same space	327 to 330

CAPS time allocation	7 hours
CAPS page references	28 and 202

Resources

Round objects such as mugs, tins or saucers to trace around to draw circles

2 cm grid paper – see the Addendum, page 426

Scissors; rulers; a piece of string about 10 cm long, for each learner

Mathematical background

The picture of the box and the questions on page 318 of the Learner Book are intended to convey an idea of the differences between the concepts of perimeter, area and volume.

When we talk about perimeter, we mean the length of a line around the outer edge of an object (like the ant's path along the red line on the top edge of the box). When we talk about area, we mean the area covered by a flat shape (like one face of the box, e.g. the area of the green face of the box). When we talk about volume, we mean the amount of space that something takes up (like one of the potatoes that occupy space).

It is not only regular shapes that have perimeter, area and volume, hence it is conceptually dangerous if learners' ideas about perimeter, area and volume are tied to regular shapes for which these dimensions can be calculated with formulas. Each of the coloured shapes alongside has a certain perimeter and a certain area. Each learner's own body has a certain volume.

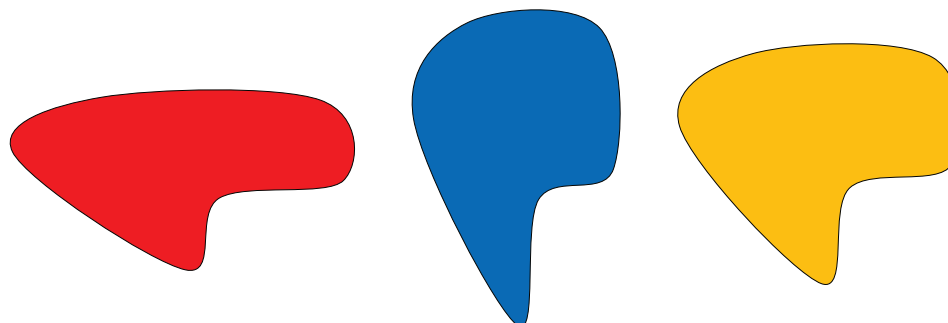

Teaching guidelines

Spend time on these four introductory questions. You want learners to *think and talk about* aspects of real situations that relate to perimeter, area and volume. It is critically important that learners form their concepts of perimeter, area and volume as a refinement of ideas about real physical objects and not on the basis of formulas for the perimeter, area and volume of regular shapes.

Use “teachers’ wait-time” when you ask a question. Wait-time means you ask the question and then you wait 10 seconds before you accept any answers. During that silence, learners are not allowed to put their hands up; instead, they must think about their answers. They also have time to think about the reason for their answer. This method gets more thinking from more of the learners, and better quality answers.

Possible misconceptions

Learners see substances change their shape, for example a drop of water spreads out on a plate and a ball of clay can be flattened out into a disc. What learners are seeing is a change in surface area, not a change in volume. Solids and liquids keep their volume even when their shape changes.

Notes on questions & Answers

1. The perimeter of the open face of the box is indicated by the red line that the ant walks along. Ask learners to trace the perimeter of the box’s green face with a finger. Walk around and make sure that learners understand what perimeter means in this question. Ask them: “*Is this perimeter as long as the red line the ant walked along?*” (Answer: No, it is shorter. Two of the sides of the open face are longer than the sides of the green face.)
2. No, it does not look as though 200 of those potatoes would fit in. (You are developing the concept of volume here. The volume of the potatoes would be greater than the capacity of the box.)
3. The potato nearest to the box, maybe. Ask learners how they decided which potato is bigger. The one nearest to the box is shorter but higher. The one further away is longer but not as high. Allow the learners to articulate themselves their reasoning behind which is the bigger.
4. The pink face, because it is bigger. It is just as high/wide as the green face, but it is longer than the green face.

UNIT
6PERIMETER, AREA AND VOLUME

The ant can crawl right around the top edge of the box, until it is back at the corner where it started.

The **perimeter** of the open face of the box is the distance that the ant will crawl if it goes around once, and stays on the red edge all the time.

1. Do you think the perimeter of the green face is equal to the perimeter of the open face of the box?
2. Do you think there is enough space inside the box for 200 potatoes like the ones shown?
3. Which of the two potatoes do you think is the biggest?
4. Suppose you want to paint the side faces of the box with expensive paint. Which face will need more paint, the green face or the pink face?

318UNIT 6: PERIMETER, AREA AND VOLUME

6.1 Perimeter

Teaching guidelines

These questions are designed to encourage learners to *think* and *talk about* perimeter. Encourage them to give reasons for their answers and to think of ways of checking their answers. This section in particular requires learners to think about perimeter and area as two different measures of flat shapes.

Notes on questions & Answers

1. Here you can listen to learners' answers, not to find out who has the right answer, but to find information about their ideas. Some learners will hear the word "biggest" and decide that the green splash is the biggest. These learners are thinking about "biggest area", not "biggest perimeter".

Notice how their thinking might change if you ask them: "*Which one has the longest perimeter; which one has the shortest perimeter?*" You could also ask them: "*If you had to draw a pencil line around the edge of each of the shapes, which shape's pencil line would take the longest to draw?*"

The yellow splash has the biggest perimeter; the green splash has the smallest perimeter.

2. You will need more paint to cover the green splash: it has the *biggest area*, even though it has the *shortest perimeter*. The yellow splash needs the least paint, because it has the *smallest area* even though it has the *longest perimeter*. This question shifts the learners' attention from perimeter to area; it reminds them that "biggest *area*" is not the same as "biggest/longest *perimeter*".
3. Perimeter of green splash: 157 mm
Perimeter of red splash: 161 mm

6.1 Perimeter

1. Which of these three splashes of paint do you think has the biggest perimeter, and which one has the smallest perimeter?



2. If you want to paint the splashes blue, which splash will need the most paint, and which will need the least paint?
3. The small rulers in the diagrams below are marked in millimetres. Measure the perimeters of the two splashes. Try to be accurate to the nearest millimetre. An enlargement of the diagram for the red splash is given on the next page, to make it easier for you.

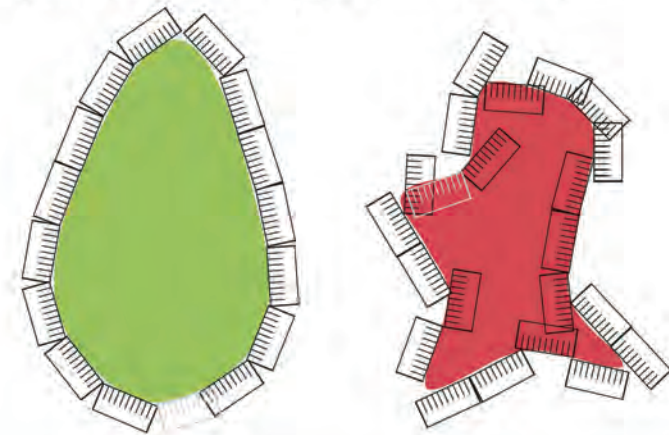

Mathematical notes

Although this is a cumbersome and apparently primitive method to approximate the perimeter of a figure, it provides learners with an early experience of a strategy that is widely used in higher mathematics: to approximate the perimeter, area or volume of curved shapes with a combination of straight lines, polygons or polyhedra.

For example, the area of the ellipse below is between the areas of the shaded areas on the left and the right below. Because of the outward curvature of the ellipse the error is smaller with the approximation on the right; hence the actual area is bigger than midway between the shaded areas on the left and the right. That means that the actual area is between the average of the two shaded areas, and the shaded area on the right. Horizontal strips will produce an even better approximation. Obviously, narrower strips will also produce better approximations. In advanced mathematics, calculations are done that reveal what the approximation would be for strips as narrow as you want them to be.

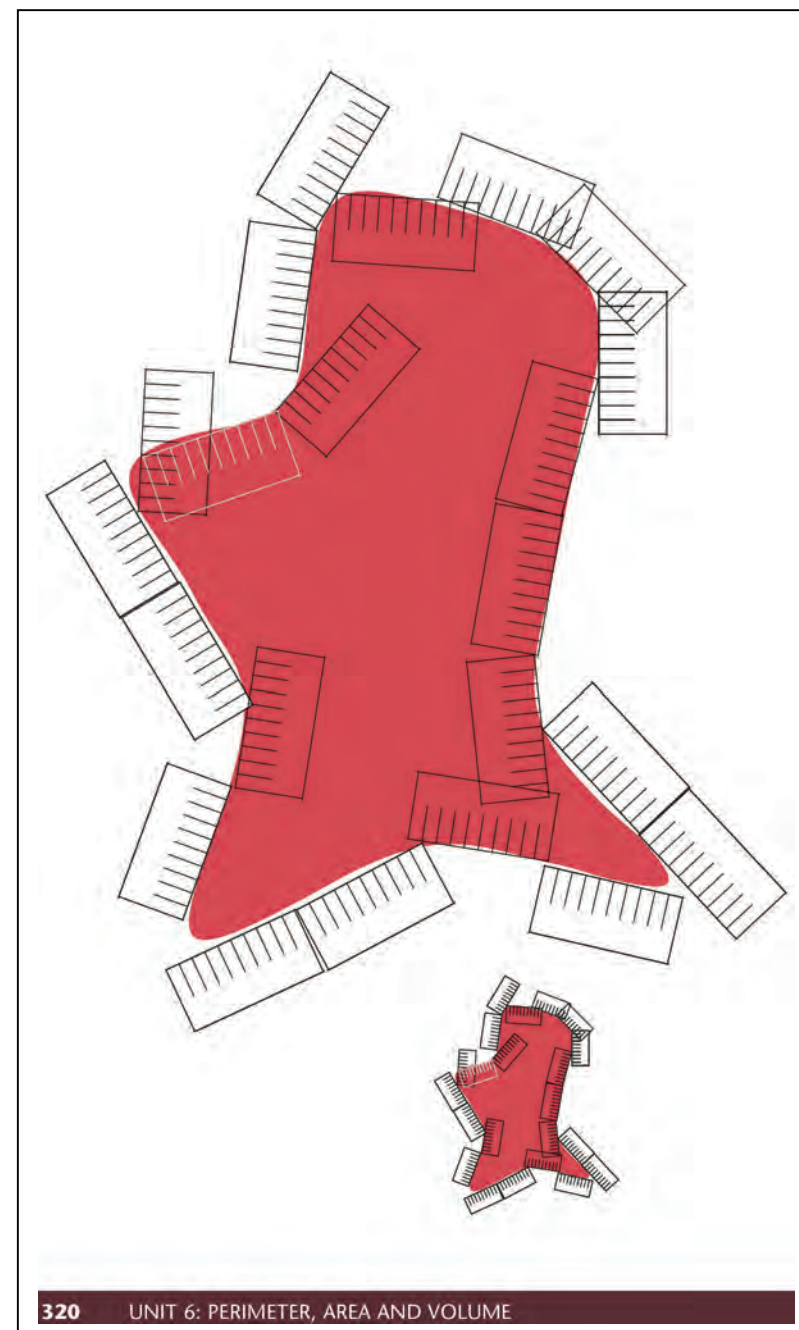
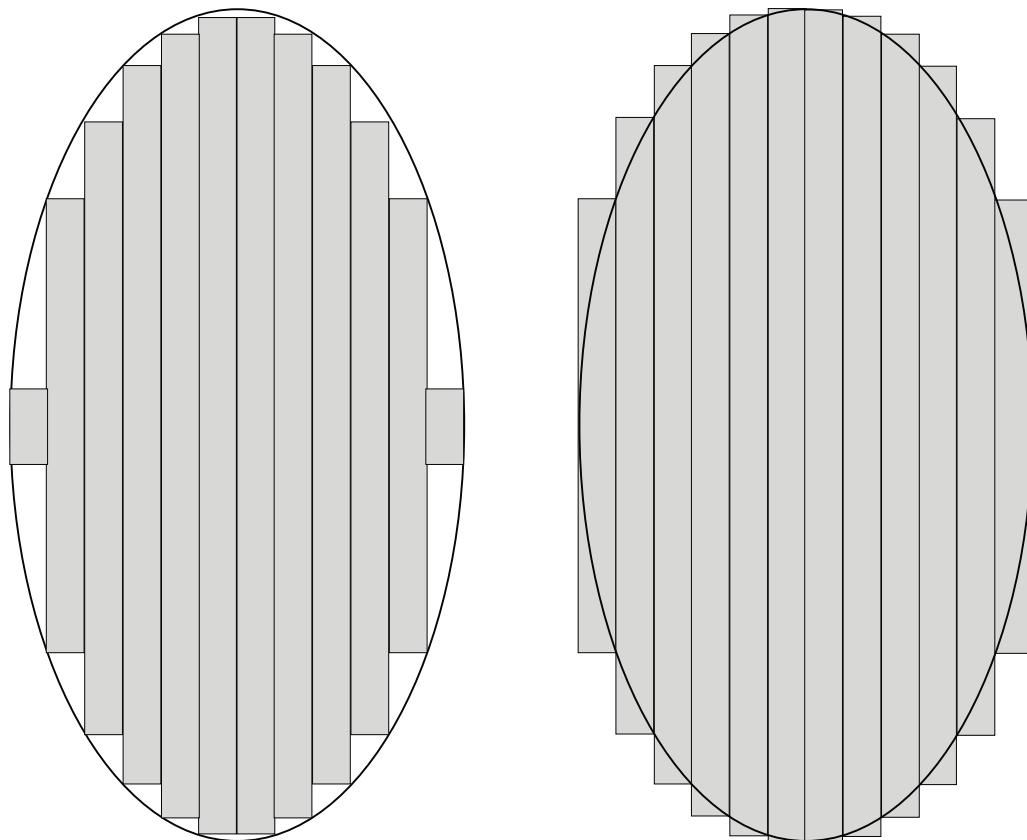

Notes on questions

Question 5 is intended to make learners aware of the fact that better approximations can be obtained by measuring shorter straight lines than by measuring longer straight lines.

Answers

4. Answers may differ slightly:

(a) $183 \text{ mm} = 18 \text{ cm}$ and $3 \text{ mm} = 18\frac{3}{10} \text{ cm}$

(b) $195 \text{ mm} = 19 \text{ cm}$ and $5 \text{ mm} = 19\frac{5}{10} \text{ cm}$ or $19\frac{1}{2} \text{ cm}$

5. The blue-edged polygon on the right-hand side

4. Measure the perimeter of these figures with your ruler. Give each of your answers in millimetres, in centimetres and millimetres, and in centimetres and fractions of a centimetre, for example:

$136 \text{ mm} = 13 \text{ cm}$ and $6 \text{ mm} = 13\frac{6}{10} \text{ cm}$.

(a)

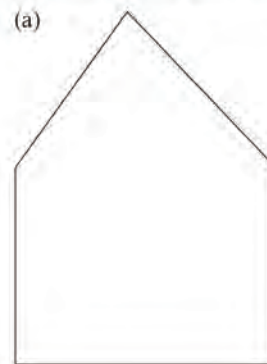

(b)

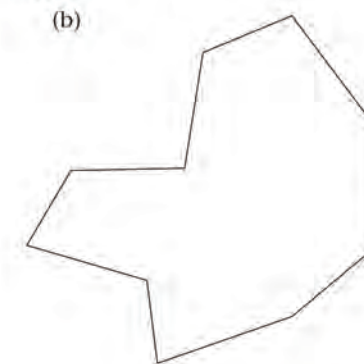

To approximately measure the perimeter of a curved figure, you can put a piece of string around the edge and then measure the length of the string.

Another method is to draw a polygon close to the curved figure, and then measure the perimeter of the polygon.



5. Which of the three polygons will provide the best approximation of the perimeter of the green curved figure?

Notes on questions & Answers

- The four circles must be the same size (i.e. their diameters must be equal, but it does not matter how big they are).
- The Learner Book does not show a diagram for this question (i.e. for the first circle), but you can refer learners to the polygons on the previous page. The more line segments the polygon has, the closer it resembles the true curved shape. In the same way, learners can draw a polygon inside (or outside) their first circle. The more line segments they draw, the closer the polygon resembles the true shape of the circle.
- If you add up the lengths of the four sides of the square inside the circle, you will find that their sum is *shorter* than the perimeter of the circle. If you add up the lengths of the four sides of the bigger square outside the circle, you will find that their sum is *longer* than the perimeter of the circle. So the true perimeter length of the circle is shorter than the outer square and longer than the inner square. Therefore option (c) is the correct answer.
- The left-hand diagram in question 9 uses the square as a guide to make it easier to draw the eight-sided polygon *outside* the circle. (Ask learners to count the eight sides.) The right-hand diagram also uses a small square as a guide to draw the eight sides *inside* the circle.

- Use a round object like a glass, mug, tin or saucer to draw a circle. Draw four copies of the circle.
- Draw a polygon inside or outside the first circle and use it to make an estimate of the perimeter of the circle.
- Draw a square outside the second circle, and another square inside the circle as shown below.

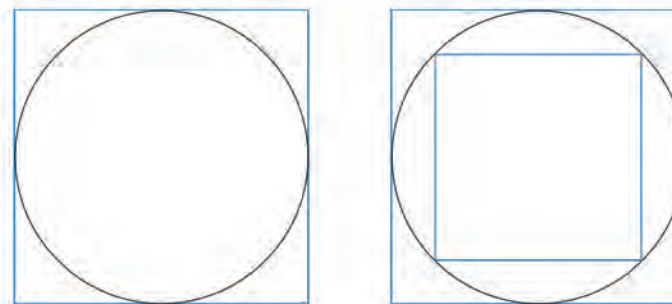

Do you think the perimeter of your circle is

- bigger than the perimeter of the outer square, or
 - smaller than the perimeter of the inner square, or
 - a number between the perimeter of the outer square and the perimeter of the inner square?
- Now use your third and fourth circles. Make drawings as shown below and use them to make a good estimate of the perimeter of each circle.

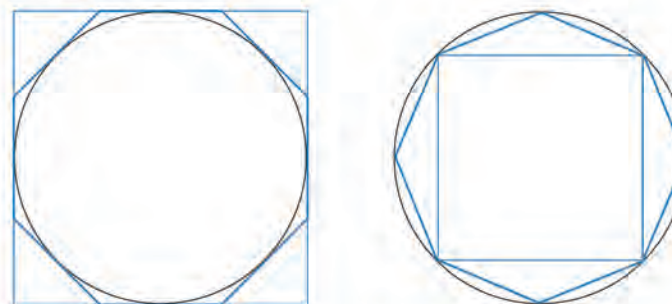

6.2 Area

Teaching guidelines

The activities in this section are designed to provoke the idea of **covering a surface** in learners' minds, as a basis for the concept of area as the number of identical squares, laid tightly together without overlapping, needed to cover the surface.

The time spent on question 1(b) is worthwhile, because it will provide learners with a powerful concrete experience of the essence of the concept of area.

2 cm grid paper is provided in the Addendum on page 426.

Notes on questions

The two splashes are identical, but they are placed in different positions relative to the grid lines. This may result in learners placing their 2 cm by 2 cm squares differently in the two cases, leading to different approximations.

The stickers need to be placed to line up with the grid lines.

Answers

- (a) 9 stickers from each splash is the correct estimate. See the diagram below.
(b) 9 stickers can be cut from each of the splashes. The purpose of the question is not to elicit an exact answer (this is not possible), but to make learners go through the physical experience of covering a surface with square pieces without overlapping or leaving gaps.

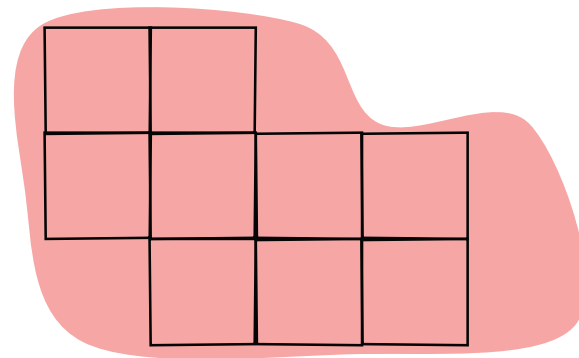

6.2 Area

- (a) Estimate how many stickers like this can be cut from each of the coloured parts on the grid below.
(b) Draw a 2 cm grid on a loose sheet of paper and cut out some 2 cm by 2 cm squares. Pack the squares on the coloured areas below to see how many can fit without overlapping.

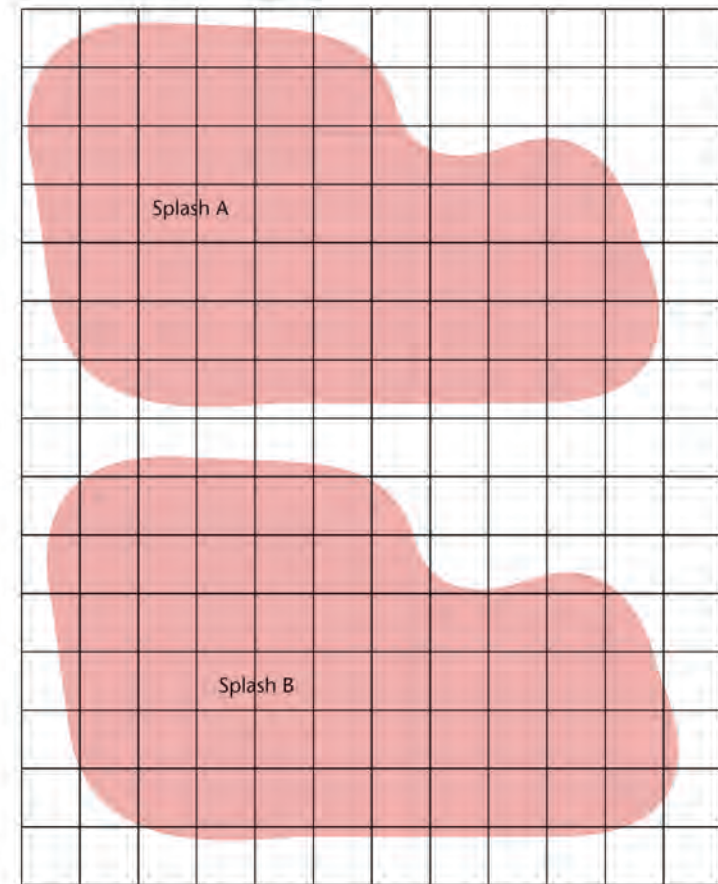

Notes on questions

In question 2 learners have to take account of the fact that only the wall will be painted, not the doors and the windows. While the wall, windows and door together cover about 30 square patches, the parts that have to be painted (including the chimney) cover about 20 square patches.

Answers

- Learners' estimates will differ.
Encourage learners to explain how they estimated.
Reasonable estimates could be between 18 and 22 square patches.
Amount of paint needed: between 4 320 ml and 5 280 ml.
- Blue covers the biggest area; red covers the smallest area.
- The blue part of the wall has an area of 22 grid squares.
The pink part of the wall has an area of 21 grid squares.
The red part of the wall has an area of 16 grid squares.

- 240 ml of paint is needed to paint one square patch of wall, 1 m by 1 m. The grid over this picture of the wall of a building shows square blocks of 1 m by 1 m.



Make a good estimate of how much paint is needed to paint the wall shown in the picture.

- This picture shows a wall painted in four different colours. If the wall is repainted, which part will need the most paint, and which part will need the least paint?

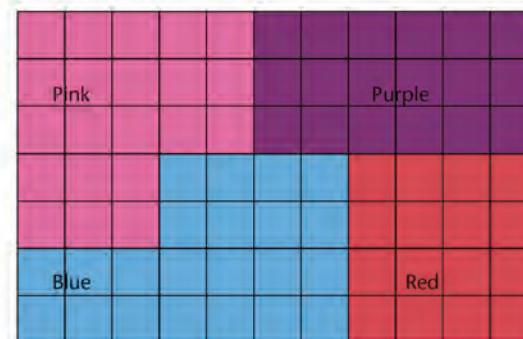

We say the red part of the wall has a smaller **surface area**, or **area** for short, than the pink part.

To compare the area of different surfaces or different parts of the same surface, you can put a grid over it and count the number of grid squares on each part.

- We can say the purple part of the wall has an area of 18 grid squares. How many grid squares is the area of each of the other three parts?

Notes on questions

Learners should simply count grid squares to get the answer. They are not expected to work with formulas to calculate the answer.

Learners need to see that each of the four shapes covers some of the grid squares only partially. In these diagrams all the partially covered grid squares are half grid squares.

Answers

5. (a) Area of the blue triangle: $24\frac{1}{2}$ grid squares

Area of the purple triangle: $4\frac{1}{2}$ grid squares

Area of the pink triangle: 8 grid squares

Area of the light green quadrilateral: 40 grid squares

(b) 77 grid squares

6. Area of red triangle: 98 grid squares

Area of blue triangle: 18 grid squares

Area of dark green triangle: 32 grid squares

Area of light green quadrilateral: 160 grid squares

7. No, they are the same size.

Learners can check this by tracing one of the triangles, cutting it out and superimposing it on the other triangle. In question 6, the grid squares are smaller: 4 grid squares in question 6 fit onto 1 grid square in question 5.

5. (a) What is the area of each coloured part of this surface?
(b) What is the area of the four parts together?

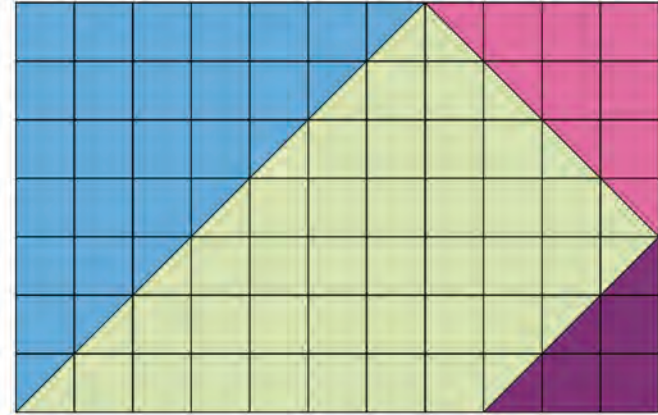

6. What is the area of each coloured part of this surface?

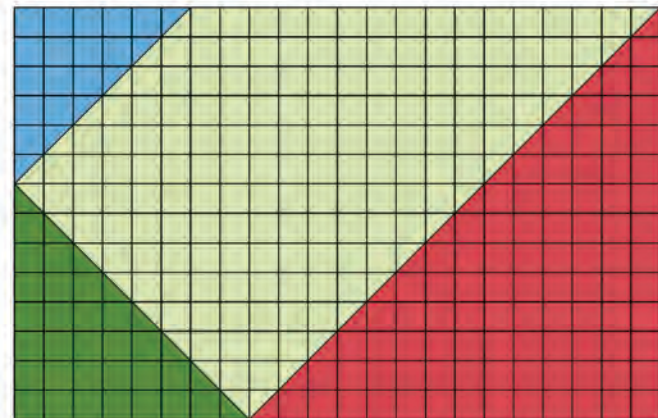

7. Is the blue triangle in question 6 bigger than the purple triangle in question 5?

Notes on questions

In question 8 learners can first estimate the areas by counting all grid squares that are completely covered by Splash A and all grid squares that are partially covered by Splash A. Learners will then see that Splash A has an area of between 37 and 68 grid squares. When they try to make whole grid squares out of part grid squares they should find that Splash A has an area of about 55 grid squares. Similarly, Splash B has between 50 and 65 grid squares. By counting grid squares and making whole grid squares out of parts, they should find that Splash B has an area of about 55 grid squares.

Learners can trace the shape of one of the coloured parts in question 9, cut it out and place it over the other part, to see that they have the same area and perimeter.

Learners can use string to find the length of the curved side, and add this to the lengths of the other three sides.

Answers

8. Splash A has an area of about 55 grid squares.
Splash B has an area of about 55 grid squares.
9. (a) The area of the two colours is equal, i.e. half the area of the rectangle:
 $38\frac{1}{2}$ grid squares.
- (b) Learners could measure the perimeters by using the millimetre scale on their rulers:
Perimeter = (half the perimeter of the rectangle) + (the length of the curved side)
= 18 grid square side lengths + about 12 grid square side lengths or
= 118 mm + about 78 mm \approx 196 mm
10. (a) Learners investigate. The dark green triangles have equal areas of approximately 38 grid squares.
- (b) Learners investigate. The perimeters differ.
Perimeter top left dark triangle: 151 mm
Perimeter top right dark triangle: 155 mm
Perimeter bottom left dark triangle: 168 mm
Perimeter bottom right dark triangle: 152 mm

8. The grid squares in question 1 on page 323 are 1 cm by 1 cm. Count the grid squares to find and compare the areas of Splash A and Splash B.

9. (a) Find the area of the purple part and of the red part of this rectangular surface.
- (b) Find the approximate perimeter of each part.

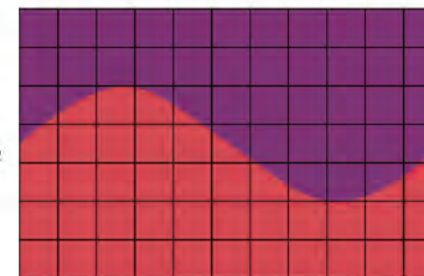

10. (a) Do the four dark triangles have equal areas? Find out.
- (b) Do the four dark triangles have equal perimeters? Find out.

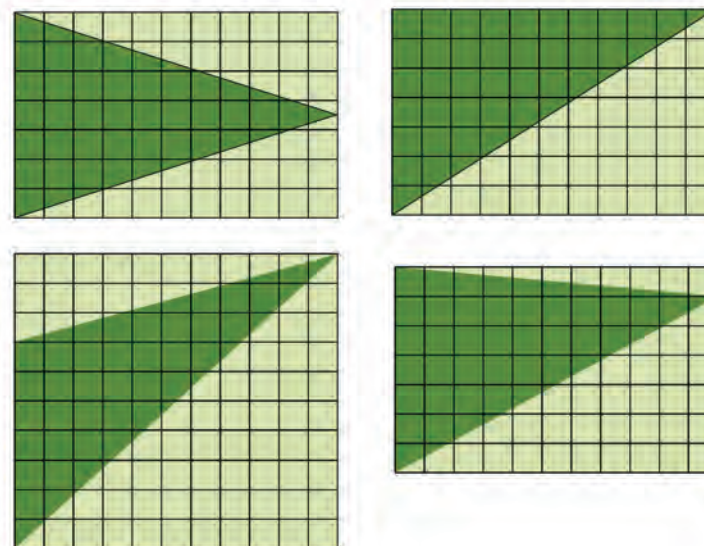

6.3 Volume and capacity

Teaching guidelines

You should remind learners that they have already worked with volume and capacity in Term 1 Unit 9.

Note that there is only one question on pages 327 and 328 of the Learner Book. The material is intended to support classroom discussions about the ideas of volume and capacity. To encourage learners to take note of the situation described in the Learner Book, you may start by asking them to figure out what the pictures and text on page 327 are all about. You may ask them: “*What do these pictures show us?*”

The purpose of question 1 is to encourage learners to *think* and *talk about* volume and capacity. You might ask question 1 in more than one way, depending on the language ability of the learners: “*Does the tray on the right have enough space for all the clay?*” means the same as “*Does the tray have enough room for all the clay?*” and “*Is the tray big enough to hold all that clay?*”

Answers

1. As stated above, the purpose of the question is to encourage learners to *think* and *talk about* volume and capacity.

6.3 Volume and capacity

Building bricks are made from wet clay.

To give shape to the bricks, wet clay is first put into trays. This is just as though you put dough into a bread pan to bake it.



1. Do you think the tray on the right has enough space for all the clay shown on the left?



To form a brick, the tray is filled with clay. The full tray is turned upside down and the tray is removed. The brick is then baked to make it dry and hard.



Almost 2 ℓ of clay is needed to make one normal brick. Hence the tray used to form bricks must have just enough space for 2 ℓ of clay. We say it has a **capacity** of 2 ℓ.

An actual brick is slightly smaller than 2 ℓ; it has a **volume** of 1 922 ml.



Teaching guidelines

To engage learners in the text and pictures on page 328 of the Learner Book, you may ask questions such as the following:

1. How much space is still available in the container at the top of the page?
2. How many of the half-litre bricks will fill up the 2-litre container?
3. How much clay can be added to the $1\frac{2}{5}$ -litre brick to fill the tray?
4. How many of the cubes of red clay are needed to make the ball of clay?

An additional classroom activity

At least 16 ml (or 16 cm^3) clay or play dough is needed for this practical activity.

The photo of the ball of clay is quite surprising; many learners won't believe that all eight of those cubes will go into that one ball of clay. So show it, with real clay.

Before the lesson, make eight cubes of 1 cm^3 and squash them together into a ball. Then make another eight cubes of 1 cm^3 each.

In the lesson, refer learners to the photo of the ball and eight cubes of clay and ask them: "If I put those eight cubes together, would they be bigger, smaller, or the same volume as the ball?"

Many learners will answer that the eight cubes have more volume than the ball.

Then ask one of them to squash all eight cubes into another ball. Ask the learner to hold up the ball and compare it with the one you made before the lesson from your own eight cubes – they will be about the same volume. The volumes of the eight little cubes are still the same as before, because none of the clay has been lost.

Mathematical notes

A ball (a sphere) is the object that can hold the greatest volume for the least outer surface area.

You could pack the eight cubes together in a block and measure the outside surface area of the block. But if you squash the cubes together into a ball, the skin of the ball will have a smaller surface area than the skin of the block. However, the *volume* of the block and the ball would be the same!

The **capacity** of a container tells us how much space the container has.

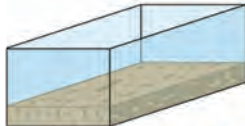

The capacity of this tray is $2\text{ l} = 2\,000\text{ ml}$

The **volume** of an object tells us how much space the object takes up.



The volume of the brick is $\frac{1}{2}\text{ l} = 500\text{ ml}$

A 2 l brick tray can be used to make smaller bricks:

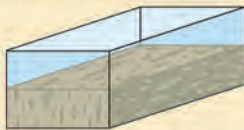

The capacity of this tray is $2\text{ l} = 2\,000\text{ ml}$

The volume of the flat brick is $1\text{ l} = 1\,000\text{ ml}$

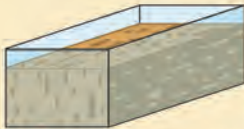

The capacity of this tray is $2\text{ l} = 2\,000\text{ ml}$

The volume of the flat brick is $1\frac{2}{5}\text{ l} = 1\,400\text{ ml}$

The ball of clay on the right takes up about the same space as 8 millilitre cubes.



Hence we can say the volume of the clay is about 8 ml. Each edge of a millilitre cube is 1 cm long.



328 UNIT 6: PERIMETER, AREA AND VOLUME

Teaching guidelines

Apart from the fact that learners may take much time to build the stacks as they are shown in the pictures, it is not necessarily useful to let learners work with actual cubes when they do these questions.

Answers

2. (a) 4 cubes
(b) 6 cubes
(c) 12 cubes
(d) 12 cubes
3. 8 cubes

To describe the volume of an object with irregular surfaces, we can state how many cubes will take up the same space.

There are 9 cubes in this stack.
Hence we can say the volume of the stack is 9 cubes.

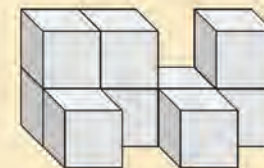

2. What is the volume of each of these stacks?

(a)

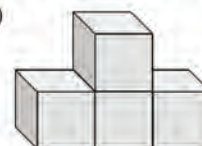

(b)

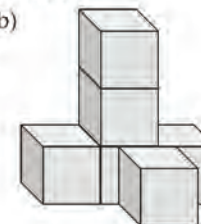

(c)

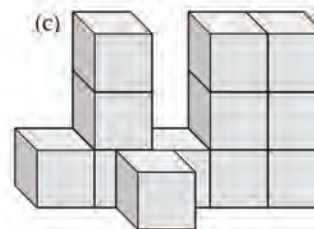

(d)

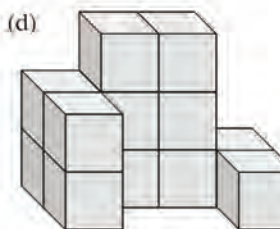

A millilitre cube is also called a **1 cm by 1 cm by 1 cm cube**, or a **centimetre cube**.



3. How many of these smaller cubes together, do you think, have the same volume as a 1 cm by 1 cm by 1 cm cube?

The edges of the smaller cubes are all 5 mm long.



Notes on questions

Make sure that learners understand that question 4 is about one stack that is shown from two different positions.

You could ask learners to work out the answer to question 5 in another way as well: they must imagine taking horizontal slices across the stack. The top slice has 4×3 cubes; the second slice has 4×5 cubes; the third slice has 4×6 cubes. Now add up all the cubes in the three slices.

Answers

4. 36 cubes
5. 56 cubes
6. (a) 27 cubes (b) 64 cubes
(c) 216 cubes (d) 125 cubes

4. Here are two different views of the same stack of cubes.

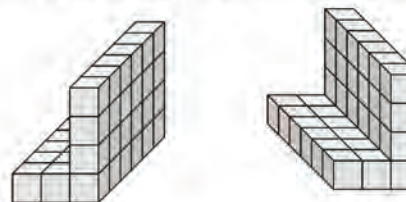

How many cubes are there in this stack?

5. How many cubes are there in the stack on the right?

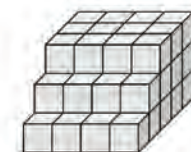

It was formed by putting the four stacks below together.

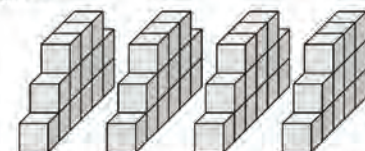

6. Each of the stacks below was formed by putting equal stacks together, like the stack in question 5. How many cubes are there in each stack?

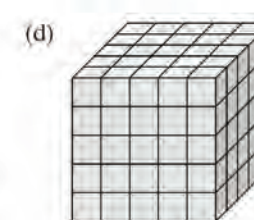
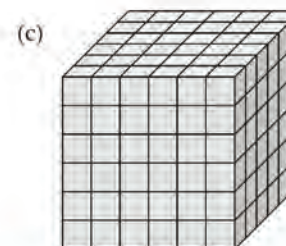
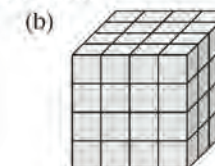
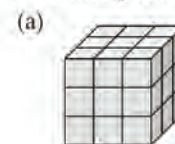

Learner Book Overview		
Sections in this unit	Content	Pages in Learner Book
7.1 Moving between positions on a grid map	Exploration of different paths that can be used to move from one position on a grid to another	331 to 332

CAPS time allocation	2 hours
CAPS page references	24 and 204

Mathematical background

Square grids are used in Mathematics as well as Geography to represent positions and movements. Each cell on a square grid has an “address” that is specified in terms of its position in relation to the so-called horizontal and vertical axes (in yellow), as demonstrated below.

The grid on the left shows **alpha-numeric addresses**, which are used in Geography and Intermediate Phase Mathematics.

The grid on the right shows **Cartesian coordinate addresses**, such as used in Mathematics from Grade 7 onwards.

Resources

Grid paper (see Addendum, page 412) or photocopies of a 10×10 grid (see Addendum, page 425)

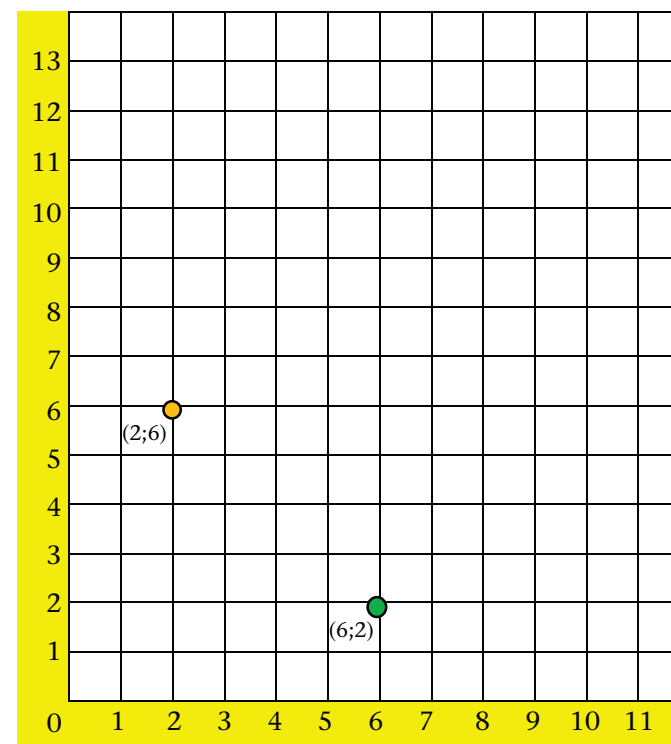
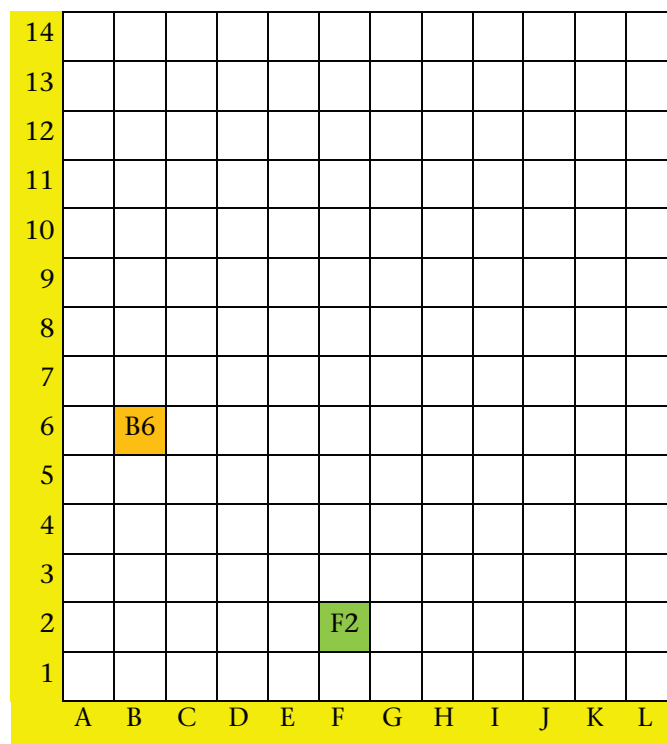

7.1 Moving between positions on a grid map

Teaching guidelines

Ideally you should draw a copy of the grid map on the board; the colour is not needed. Tell learners that “moving back” as indicated in red on the left below is not allowed. Allow learners to come to the board and indicate some other ways to get from A1 to C4 by moving only left or right, and up or down. Two ways are shown below, in the middle and on the right. There are several more ways.

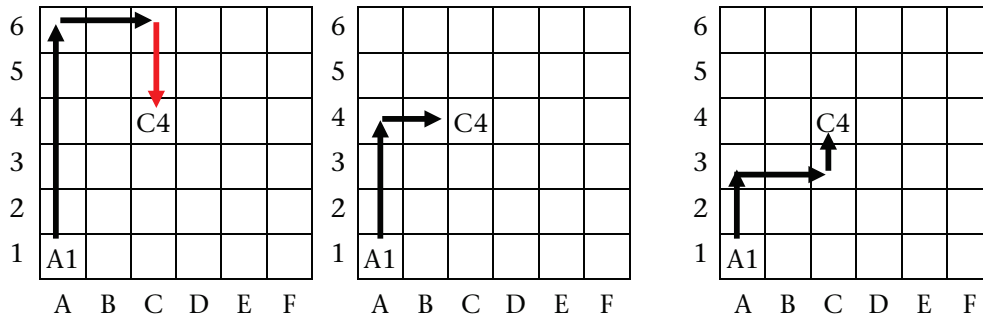

Keep the above on the board for the explanations that you may need to do after question 2 on the next page.

To save time, you could provide learners with photocopies the grid provided on page 425 in the Addendum.

Answers

1. Grid map:

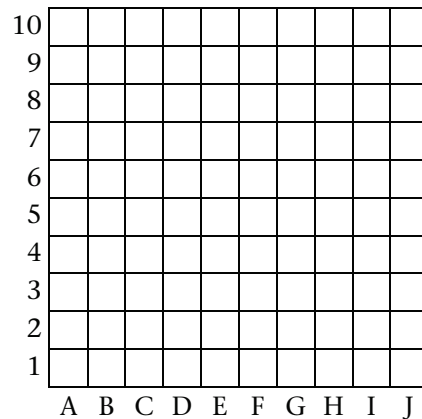

UNIT

7

POSITION AND MOVEMENT

7.1 Moving between positions on a grid map

The rules for moving on a grid map are as follows:

- You may not move in a slanted direction.
- You may move right or left.
- You may move up or down.
- You may never move backwards.

For example, if you want to get from Block A1 to Block C4, you may move two blocks to the right and three blocks up.

Is there another way?

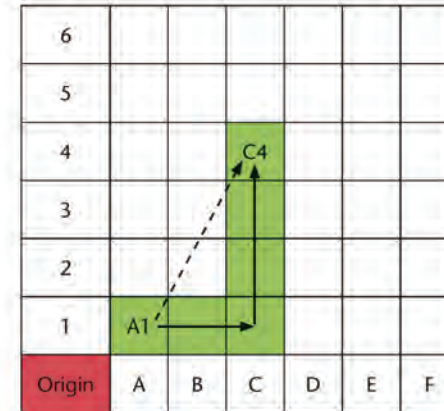

1. Work on squared paper. Make a grid map with the origin in the bottom left corner of the page. Your map must have 10 columns from left to right, and 10 rows from top to bottom. Label the blocks from left to right with the letters A to J. Label the blocks from bottom to top with numbers 1 to 10.

Teaching guidelines

After learners have done question 2, you will have to explain to them what is meant by 1 unit of distance, as described in the tinted passage.

Answers

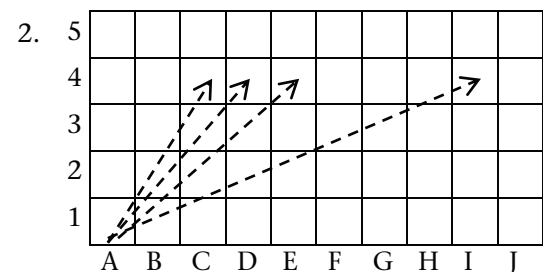

- (a) Possibilities:
 2 units to the right and 3 units up;
 1 unit right, 3 units up, 1 unit right;
 3 units up, 2 units to the right;
 2 units up, 1 unit right, 1 unit up,
 1 unit right.
 There are several more possibilities.

(b), (c), (d): Many possibilities in each case, similar to (a) but more.

3. (a) 5 units (b) 6 units
 (c) 7 units (d) 12 units
4. There are many possibilities; see answer for question 2.
5. (a) and (b) A10 and J1, also A1 and J10

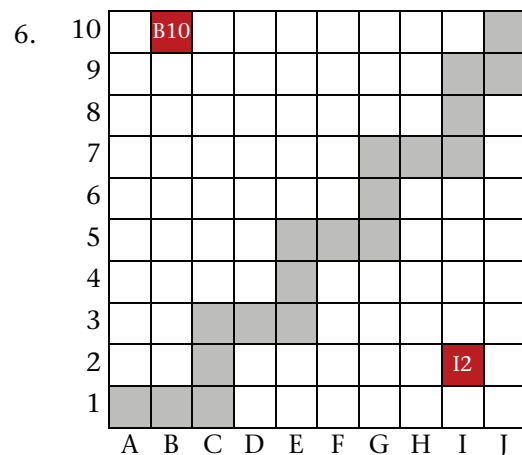

Distance from A1 to J10:
 18 units

7. See the red blocks above. A large number of different routes are possible, for example:
 Route 1: B10 to B2, B2 to I2
 Route 2: B10 to F10, F10 to F6, F6 to I6, I6 to I2
 The distance is the same for all routes: 15 units.

2. Draw straight dotted lines between the following pairs of blocks. Explain how to move on the map between the blocks. Remember, you may not move on the slanted dotted lines that you drew!
- (a) A1 and C4 (b) A1 and D4
 (c) A1 and E4 (d) A1 and J4

Let each block be 1 unit of distance.
 This means we move 2 units from A1 to get to C1.
 We move 3 units to get from C1 to C4.
 We move 5 units to get from A1 to C4.

3. How many units do you move between the following blocks?
 (a) A1 and C4 (b) A1 and D4
 (c) A1 and E4 (d) A1 and J4
4. Describe a different way to move between the pairs of blocks in question 2.
5. (a) Which two blocks on your grid map are the greatest distance from each other?
 (b) Are the blocks that you identified in (a) the only blocks that are this far apart?
6. You want to move from A1 to J10. Shade the following blocks for your journey:
 A1 to C1; C1 to C3; C3 to E3; E3 to E5; E5 to G5; G5 to G7;
 G7 to I7; I7 to I9; I9 to J9; J9 to J10.
 Compare your journey with a classmate to make sure you did not miss any steps. What distance did you move from A1 to J10?
7. Mark the following blocks on the grid: B10 and I2.
 Write down two different grid routes to get from B10 to I2. Make sure you do not turn back with any move.
 Compare the distances of your routes.

Learner Book Overview		
Sections in this unit	Content	Pages in Learner Book
8.1 Rotations, reflections and translations in art	Transformations in art and design	333 to 334
8.2 Tessellations	Covering a flat surface with tiles that fit snugly (no gaps)	335 to 337

CAPS time allocation	4 hours
CAPS page references	23 and 205

Mathematical background

Artists and graphic designers often use rotations, translations and reflections in their work.



Tessellations are patterns formed by positioning objects (tiles) with the same shape to cover an area, or by repeating shapes when painting a surface. There are no gaps or overlaps in a tessellation. The process of arranging the identical shapes involves transformations: we can imagine each tile in a tessellation to be translated, rotated or reflected compared to the other tiles.

Tessellations occur in nature, for example in honeycombs and on fish and snakes, as well as in man-made structures such as brick walls, pavements, and wall and floor tilings.

Some tessellations are more complex and have two or more different tile shapes or sizes. The extreme is a mosaic where every single tile may be different to all the others.

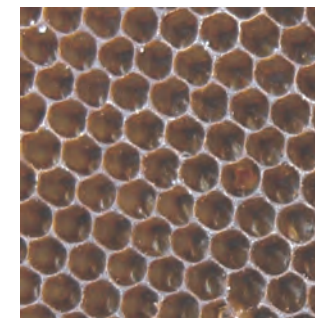

8.1 Rotations, reflections and translations in art

Teaching guidelines

Learners have engaged with rotations, translations and reflections before, but it would be good to quickly refresh their knowledge. You may do so by drawing simple examples on the board, like those on page 244 of the Learner Book.

Notes on questions

Allow learners to articulate and describe in their own words the figures and the transformations that they can identify. Developing and confirming the vocabulary to describe a transformation is important. Learners need to have clarity about what constitutes a translation, a rotation and a reflection.

Answers

1.

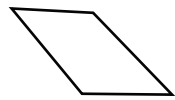

Copy



Reflection

2. Example:

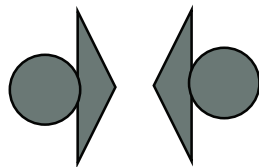

Learners could point out other figures. Consider all learners' drawings.

UNIT
8
TRANSFORMATIONS

8.1 Rotations, reflections and translations in art



This is an artwork by the famous Ndebele artist Esther Mahlangu.

The drawing below shows one of the reflections in the above artwork.

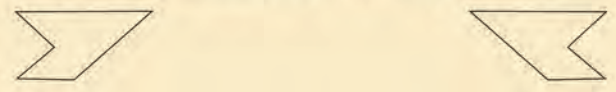

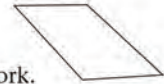
- In the above artwork, there is also a reflection of the figure shown here:
 Draw a copy of this figure, and its reflection as you can see it in the artwork.
 
- Draw a copy of another figure and its reflection that you see in the artwork.

GRADE 5: MATHEMATICS [TERM 4]
333

Teaching guidelines

In answering these questions, learners should focus on the outlines of shapes, not on the decorative detail within shapes.

Answers

3. (a) In the upper right of the part of the artwork shown in question 3, the green pentagon is a rotation of the maroon pentagon.



- (b) A vertical reflection



- A horizontal reflection



4. (a) and (b)

The black triangle is a rotation of the blue triangle in each of these three examples.

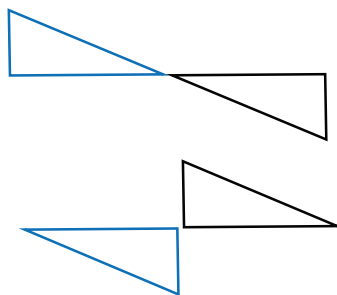
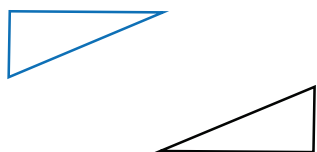

5. (a) The blue triangles in the upper left and lower right parts of the artwork are rotations of each other (they are also reflections of each other). The same goes for the maroon triangles on the lower left and upper right. The pink arrows in the middle are rotations of each other (they are also reflections of each other). The same goes for the grey arrows.

- (b) At the top,



and at the bottom:



This drawing shows one of the rotations in the artwork.

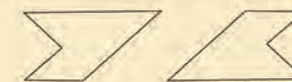

3. There is also a rotation of this figure in the artwork:

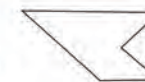

- (a) Draw a copy of the figure and its rotation as you see it in the artwork.

- (b) Draw a reflection of this figure.



4. (a) Make a drawing of a black triangle and its rotation that you see in the bottom part of the artwork above.
 (b) Make a drawing of another rotation of the same triangle that you see in the artwork.
5. (a) Make a drawing of a figure and its rotation in the artwork below, where the colours are the same in the two figures.
 (b) Make a drawing of a figure and its rotation in the artwork below, where the colours are different in the two figures.



8.2 Tessellations

Mathematical notes

Tessellations often involve repeated arrangement of a tile. Since each tile is next to another tile, there may be translation or reflection involved. In cases where tiles must be turned to fit, rotation is involved.

Each of the tessellations in this section is made up of a single shape. It is a fact that any triangle will tessellate. This is also true for quadrilaterals.

Teaching guidelines

This section is very brief. There is a great deal more to tessellations than space or time permits here.

If time permits, you may wish to include additional tile shapes to tessellate. Printing and cutting many copies of the same triangle or quadrilateral will provide you with additional tessellation activities. Give each learner his/her own shape (triangle or rectangle), allow them to create their own tessellation through transformation of their shape, and let them describe their tessellation.

Possible misconceptions

It is possible to arrange tiles so that they do not tessellate, i.e. that there are gaps between the tiles. If learners do this, remind them that there are no gaps in a tessellation. Otherwise they may believe that the activities are about arranging tiles in any pattern, including non-tessellating patterns. This will probably force them into trying to rotate or reflect a tile to ensure no gaps occur, which will serve the main focus of this section well.

Answers

- (a) Practical work
(b) The statements are true.
- (a) The red quadrilaterals
(b) The yellow quadrilaterals
(c) No
- Learners' own work

8.2 Tessellations

- (a) Trace a copy of this quadrilateral onto thick paper or cardboard and cut it out.
(b) Move your quadrilateral on the figures below to check whether the statements are true.

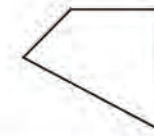

The red figure is a **reflection** of the black figure.

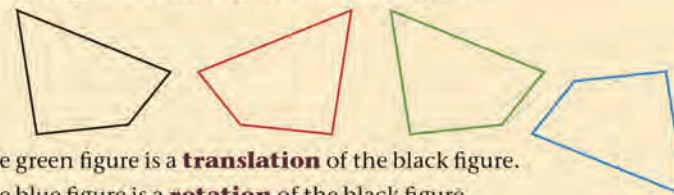

The green figure is a **translation** of the black figure.

The blue figure is a **rotation** of the black figure.

You can use your cut-out quadrilateral when you do question 2.

- (a) Which quadrilaterals in the tessellation below are translations of the black quadrilateral?
(b) Which quadrilaterals are rotations of the black quadrilateral?
(c) Is there a reflection of the blue figure in the tessellation?

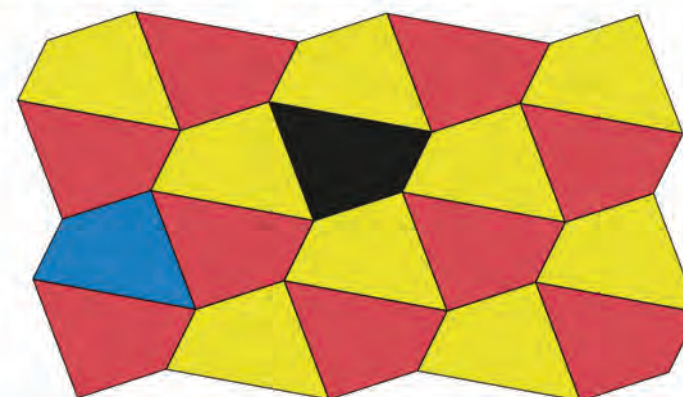

- Use your cut-out quadrilateral to draw a copy of this tessellation.

Answers

4. and 5. Practical work

6. (a) Yes

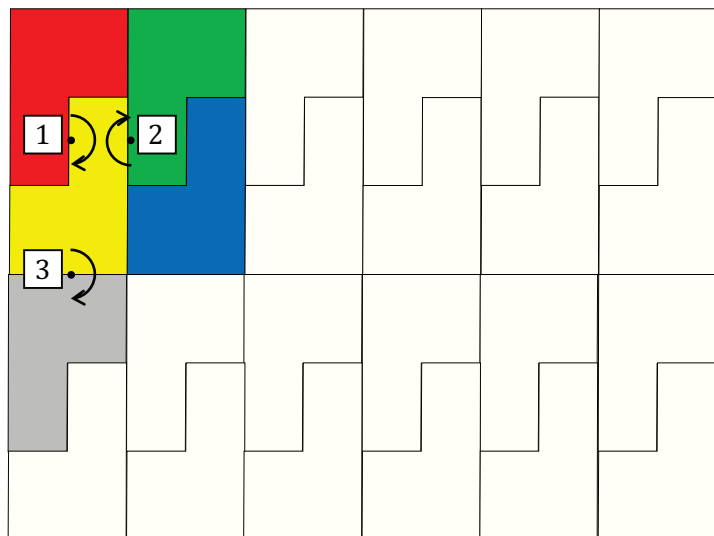

The template in the red position is rotated through half a revolution around point 1, to move it to the yellow position. When the template is in the yellow position, it is rotated through half a revolution around point 2, to move to the green position. These two movements are then made repeatedly to move the template from one position to the next horizontally.

From the yellow position the template can be rotated around point 3 to move it to the grey position.

(b) No

(c) No

7. Yes

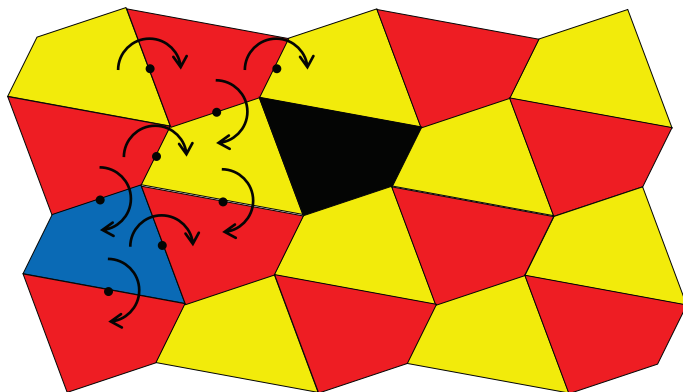

4. Trace a copy of this hexagon onto thick paper or cardboard and cut it out.

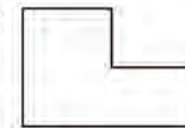

You will use it as a template to draw tessellations when you do questions 5 to 9.

5. (a) Put your template in the red position below, then rotate it to the yellow position.

(b) Translate the template from the yellow position to the blue position.

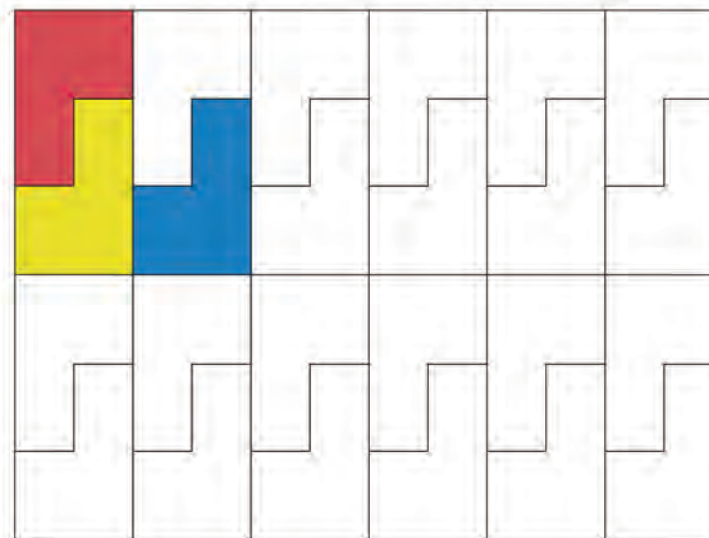

(c) Continue to rotate and translate the template until you have covered all the hexagons in the tessellation.

6. (a) Can you draw the above tessellation by making rotations only?

(b) Can you draw it by making reflections only?

(c) Can you draw it by making translations only?

7. Can you draw the tessellation in question 2 by making rotations only with the quadrilateral template?

Notes on questions

It is important that learners use the terms “translation”, “rotation” and “reflection” to describe how they moved a shape to create a tessellation.

You can ask learners whether they notice anything about the way the shapes are placed in relation to each other. The importance of no open spaces in a tessellation may lead learners to realise that shapes in a tessellation are generally placed with sides of equal lengths alongside each other in order to create a perfect fit, leaving no open spaces. Also, the sides of different shapes are combined to form another side length to place a shape against.

Answers

8. (a) Practical work
- (b) Learners describe their tessellation movements.
9. Learners’ own work
10. Practical work. The pentagon cannot tessellate; all the other shapes can.

8. (a) Use your hexagon template to draw a copy of this tessellation.

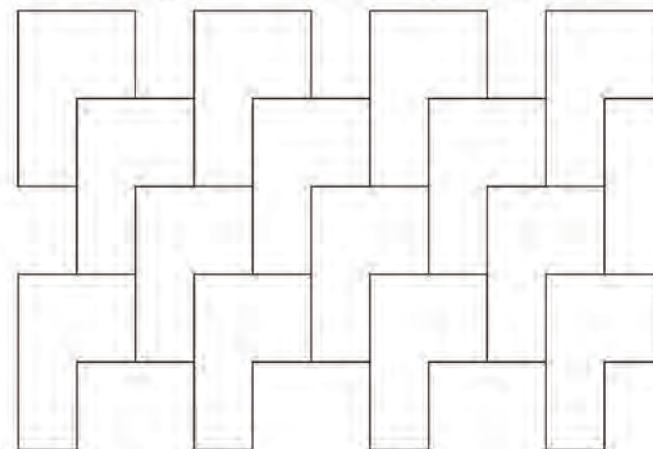

- (b) In what way did you move the template to draw this tessellation?

9. Use reflections only to draw another tessellation with your hexagon template.
10. Select one of the figures below, make a template, and draw a tessellation if you can. Describe how you moved your template to draw the tessellation.

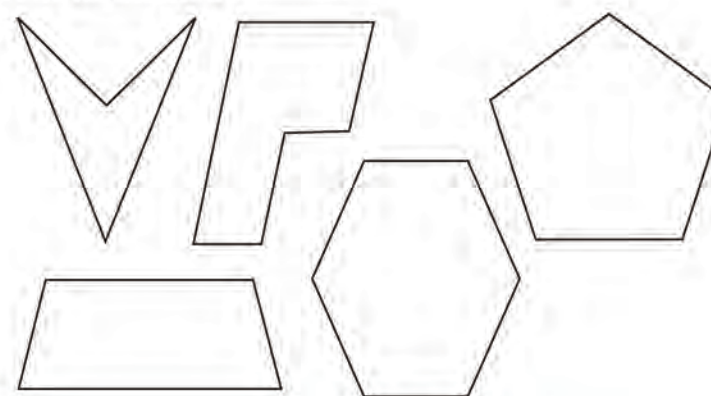

Learner Book Overview		
Sections in this unit	Content	Pages in Learner Book
9.1 Making a geometric pattern	A geometric illustration of making a sequence by following a rule	338
9.2 Describing patterns	Several related patterns distinguishing between constants and variables	339 to 340
9.3 Completing tables	From a geometric pattern to a table (numeric patterns)	341

CAPS time allocation	2 hours
CAPS page references	19 and 206

Continuing sequences or completing tables according to a pattern not only provides opportunities to develop understanding of patterns, but also contributes to the development of the **Mental Mathematics** section of the CAPS.

Mathematical background

As in Term 2 Unit 7, the approach in this unit is not to reduce the work on geometric patterns to numeric patterns in tables but to use the *visual aspects* of geometric representations as a method to find **rules** based on the *structure* of the geometric figures.

As stated before, this implies that you should help learners to not count the number of dots in a figure one by one but to use “clever counting” instead, by identifying appropriate larger, repeating units. Learners then shouldn’t just count the larger, repeating units – they should also write down a **numerical expression** (calculation plan or **rule**) describing the number of dots. It is very important that learners learn to withhold immediate calculation of a numerical expression – what is needed, is to analyse the structure of the expression as an object, and to *generalise the structure*, not to generalise numbers.

To find a general rule for the pattern requires a second level of pattern recognition, namely recognising the structure in a series of numerical expressions – what doesn’t change (is **constant**) and what changes (is **variable**). This process is illustrated below.

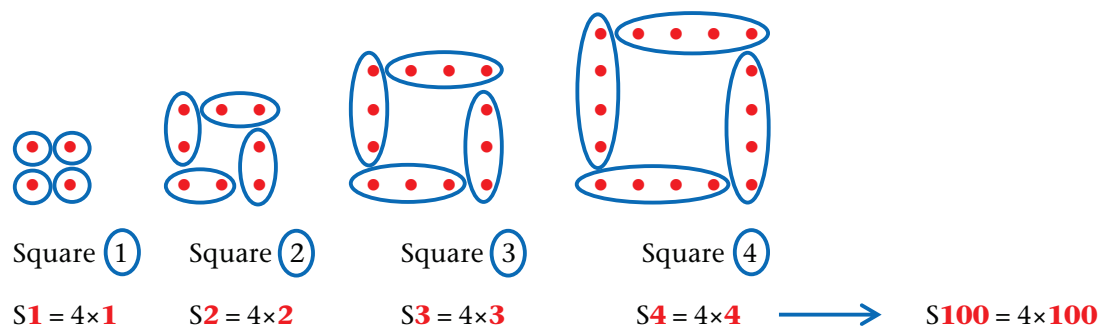

“The mathematician’s patterns, like the painter’s or the poet’s, must be beautiful; the ideas, like the colours or the words, must fit together in a harmonious way. Beauty is the first test.”

GH Hardy

9.1 Making a geometric pattern

Teaching guidelines

This section provides learners with an experience of the process of making an interesting geometric pattern (sequence), namely to repeat the same steps (rule) to make each next figure in the pattern (or each next number in the sequence). In this case, the rule is to form a new square by joining the midpoints of the sides of the innermost square.

You should either directly teach the process by letting learners close their books while you dictate “Draw a square and colour it,” etc., or you should make sure that learners understand the process before tackling the questions.

Although the section starts with a geometric pattern, we later transform it into a numeric pattern.

The numeric pattern involves fractions. Learners can find the fractions by drawing appropriate lines to divide each figure into an equal number of parts, as illustrated here.

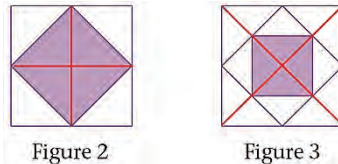

However, after using the pictures to find the first few fractions, learners should not continue in the geometric context, but rather use the numeric sequence as a model to imitate the geometry.

It should be clear that in the numeric sequence the **horizontal pattern** is to halve the previous number. Learners have met this before, namely on page 264. They should find it relatively easy to continue halving all the way to the tenth number.

However, instead of continuing the horizontal pattern of halving up to 10, it may be easier to use the **vertical pattern** (rule) to find the tenth number directly. We emphasise again that we do not generalise the *numbers*, but the *structure*, as illustrated here:

1	2	3	4	5	10
1	$\frac{1}{2}$	$\frac{1}{2 \times 2}$ 2 times	$\frac{1}{2 \times 2 \times 2}$ 3 times	$\frac{1}{2 \times 2 \times 2 \times 2}$ 4 times	$\frac{1}{2 \times 2 \times 2 \times 2 \times 2 \times 2 \times 2 \times 2 \times 2 \times 2}$ 9 times

Answers

- $\frac{1}{2}$; $\frac{1}{4}$
- Every new square (the coloured part) is half of the previous one.
Keep on halving the number to get the next one in the pattern.

Figure no.	1	2	3	4	5	6	10
Fraction of figure that is coloured	1	$\frac{1}{2}$	$\frac{1}{4}$	$\frac{1}{8}$	$\frac{1}{16}$	$\frac{1}{32}$	$\frac{1}{512}$

UNIT

9

GEOMETRIC PATTERNS

9.1 Making a geometric pattern

Mathume makes this interesting sequence of pictures. He makes each new picture by repeating the same steps.

- He starts with a square (Figure 1) and colours it.
- To make Figure 2, he first draws a square of the same size as Figure 1. He then connects the midpoints of the sides of the square to form a new smaller square inside the square and then he colours the smaller square.
- To make Figure 3, he again connects the midpoints of the sides of the new square as shown.
- He continues with these same steps to make more and more pictures.



Figure 1



Figure 2



Figure 3



Figure 4

1. If we think of Figure 1 as the whole (1), what fraction of the whole figure is coloured in Figure 2? What fraction is coloured in Figure 3?
2. Complete this table to show Mathume's geometric sequence as a numeric sequence.

Explain your methods and discuss patterns in the table.

Figure no.	1	2	3	4	5	6	10
Fraction of figure that is coloured	1						

9.2 Describing patterns

Teaching guidelines

You should try to let all learners attempt all the pattern designs. If learners have the mindset not to tackle problems in isolation but to always think about *the relationship between the patterns*, it will help conceptually and timewise.

Notes on questions

There are several important mathematical concepts embedded in the context, including that of **constant** and **variable**. These concepts will arise naturally from the identification of “counting units” in the pictures, as illustrated here for Pattern 1 and Pattern 4.

Pattern 1

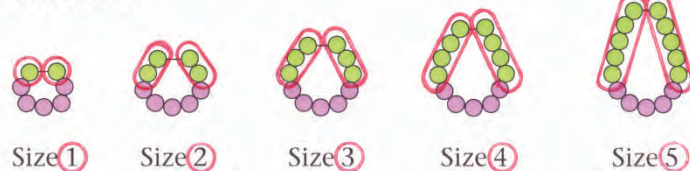

Green:	2×1	2×2	2×3	2×4	2×5
Purple:	5	5	5	5	5
Total:	$2 \times 1 + 5$	$2 \times 2 + 5$	$2 \times 3 + 5$	$2 \times 4 + 5$	$2 \times 5 + 5$

Pattern 4

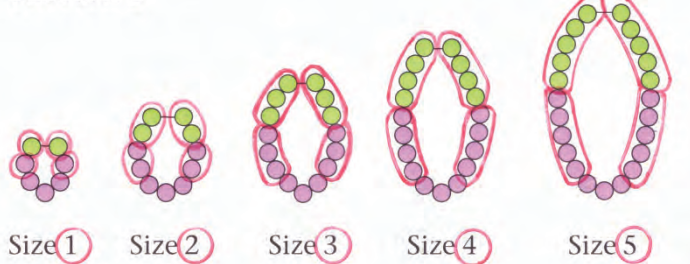

Green:	2×1	2×2	2×3	2×4	2×5
Purple:	$2 \times 1 + 3$	$2 \times 2 + 3$	$2 \times 3 + 3$	$2 \times 4 + 3$	$2 \times 5 + 3$
Total:	$4 \times 1 + 3$	$4 \times 2 + 3$	$4 \times 3 + 3$	$4 \times 4 + 3$	$4 \times 5 + 3$

Learners should do and *discuss* all four questions in this section.

9.2 Describing patterns

Mandla makes these different patterns of bead necklaces of different sizes.

Pattern 1



Pattern 2

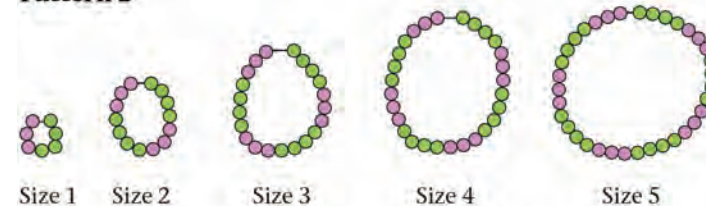

Pattern 3

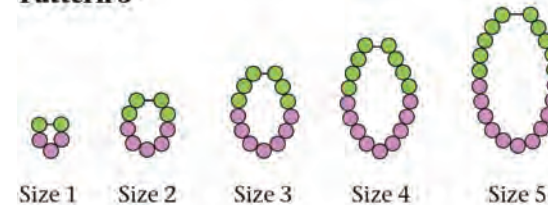

Pattern 4

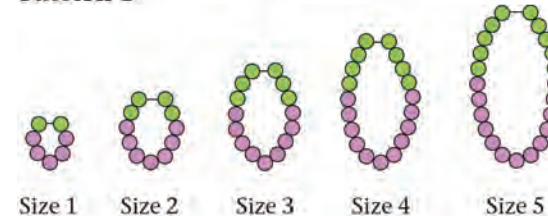

Answers

1. (a) Green: $2 \times 6 = 12$ Purple: 5 Total: $2 \times 6 + 5 = 17$
 (b) Green: $2 \times 20 = 40$ Purple: 5 Total: $2 \times 20 + 5 = 45$

(c)

Size no.	1	2	3	4	5	6	20
No. of green beads	2	4	6	8	10	12	40
No. of purple beads	5	5	5	5	5	5	5
Total no. of beads	7	9	11	13	15	17	45

- (d) 7, 8, 9, 10, 15 \rightarrow $\boxed{\times 2} \boxed{+ 5} \rightarrow 19, 21, 23, 25, 35$

2. (a) Green: $6 \times 4 = 24$ Purple: $6 \times 3 = 18$ Total: $6 \times 7 = 42$
 (b) Green: $20 \times 4 = 80$ Purple: $20 \times 3 = 60$ Total: $20 \times 7 = 140$

(c)

Size no.	1	2	3	4	5	6	20
No. of green beads	4	8	12	16	20	24	80
No. of purple beads	3	6	9	12	15	18	60
Total no. of beads	7	14	21	28	35	42	140

- (d) 7, 8, 9, 10, 15 \rightarrow $\boxed{\times 7} \boxed{+ 0} \rightarrow 49, 56, 63, 70, 105$

3. (a) Green: $2 \times 6 = 12$ Purple: $2 \times 6 + 1 = 13$ Total: $4 \times 6 + 1 = 25$
 (b) Green: $2 \times 20 = 40$ Purple: $2 \times 20 + 1 = 41$ Total: $4 \times 20 + 1 = 81$

(c)

Size no.	1	2	3	4	5	6	20
No. of green beads	2	4	6	8	10	12	40
No. of purple beads	3	5	7	9	11	13	41
Total no. of beads	5	9	13	17	21	25	81

- (d) 7, 8, 9, 10, 15 \rightarrow $\boxed{\times 4} \boxed{+ 1} \rightarrow 29, 33, 37, 41, 61$

4. (a) Green: $2 \times 6 = 12$ Purple: $2 \times 7 + 1 = 15$ Total: $2 \times (6+7) + 1 = 27$
 (b) Green: $2 \times 20 = 40$ Purple: $2 \times 21 + 1 = 43$ Total: $2 \times (20+21) + 1 = 83$

(c)

Size no.	1	2	3	4	5	6	20
No. of green beads	2	4	6	8	10	12	40
No. of purple beads	5	7	9	11	13	15	43
Total no. of beads	7	11	15	19	23	27	83

- (d) 7, 8, 9, 10, 15 \rightarrow $\boxed{\times 4} \boxed{+ 3} \rightarrow 31, 35, 39, 43, 63$

1. For Pattern 1:

- (a) Describe a Size 6 necklace in words.
 How many green beads, how many purple beads, and how many beads in total are there in a Size 6 necklace?
 (b) Describe a Size 20 necklace in words.
 How many green beads, how many purple beads, and how many beads in total are there in a Size 20 necklace?
 (c) Complete this table. Describe and discuss your methods.
 Describe and discuss what patterns you see in the table.

Size no.	1	2	3	4	5	6	20
No. of green beads	2	4					
No. of purple beads	5	5					
Total no. of beads	7	9					

- (d) Complete this flow diagram as a plan to calculate the total number of beads for different sizes of necklaces. Then calculate the missing output numbers.

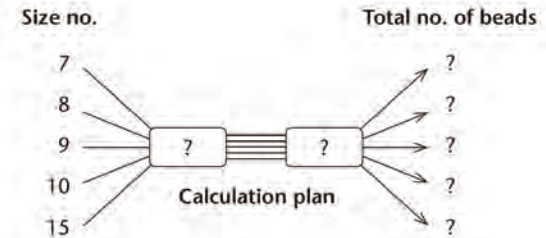

2. For Pattern 2, answer the same questions as for Pattern 1.
 3. For Pattern 3, answer the same questions as for Pattern 1.
 4. For Pattern 4, answer the same questions as for Pattern 1.

9.3 Completing tables

Mathematical notes

The geometric pattern in this section introduces two new kinds of numeric patterns, which are different from the usual multiples and common differences we have been studying, namely:

- triangular numbers: 1, 3, 6, 10, 15, ...
- square numbers: 1, 4, 9, 16, 25, ...

These two sequences are different, but they are the same in that they have the same type of **horizontal pattern** of increasing differences:



These two sequences can be represented as geometric triangles and squares, as illustrated here, and this does explain their names.

The geometric representation of square numbers then gives us an easy **vertical rule** to calculate further-lying values instead of continuing the horizontal pattern, for example $S_{10} = 10 \times 10$.

The triangular numbers do not have such an easy vertical rule, but the geometric representation helps us to calculate further-lying values in a clever way, for example to calculate the number of yellow tiles in Figure no. 10:

$$T_{10} = 1 + 2 + 3 + 4 + 5 + 6 + 7 + 8 + 9 + 10$$

$$= (1+10) + (2+9) + (3+8) + (4+7) + (5+6) \dots = 5 \times 11 = 55$$

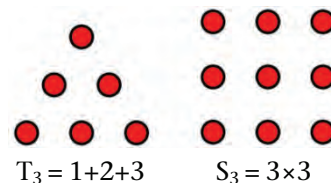

Answers

1.	Figure no.	1	2	3	4	5	6	10
	No. of yellow tiles	1	3	6	10	15	21	55
	No. of white tiles	3	6	10	15	21	28	66
	Total no. of tiles	4	9	16	25	36	49	121

2. There is an increasing difference between consecutive numbers for each row, for example for the yellow tiles:
3. $51 \times 51 = 2\,601$ triangles



9.3 Completing tables

Look at this growing geometric pattern of triangles:

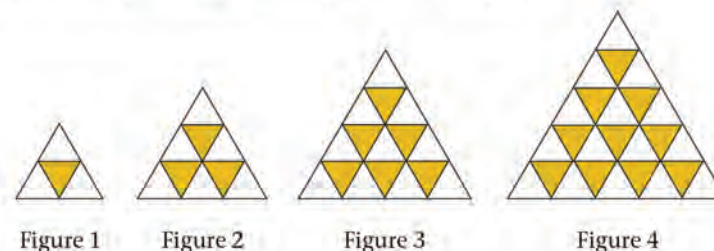

1. Complete this table. Describe and discuss the methods that you used.

Figure no.	1	2	3	4	5	6	10
No. of yellow tiles	1	3					
No. of white tiles	3	6					
Total no. of tiles	4	9					

2. Describe and discuss horizontal numeric patterns in the table.
3. How many triangles are there in total in Figure 50?

Learner Book Overview		
Sections in this unit	Content	Pages in Learner Book
10.1 Solve and complete number sentences by trial and improvement	Learning to solve number sentences with the “numerical method”, and doing Mental Mathematics	342 to 343
10.2 Flow diagrams, number sentences and tables	An investigation in which flow diagrams, number sentences and tables are used to solve a practical problem	344 to 345

CAPS time allocation	3 hours
CAPS page references	20 and 207

Apart from developing the numerical method, Section 10.1 on page 342 of the Learner Book provides for extensive practice in **Mental Mathematics**.

Mathematical background

Solving number sentences by trial and improvement is a very valuable experience for learners, for at least three reasons:

- It provides them with opportunities to develop a robust understanding of the meaning of open number sentences (equations).
- It provides them with a basic experience of the so-called “numerical solution” of equations, which is of utmost importance in modern mathematical practice.
- It provides computation practice in a meaningful mathematical context.

The first step in solving an open number sentence by trial and improvement is to **select a first trial number**.

For example, when solving $100 - 3 \times \square = 5 \times \square - 4$, you could take 1 as the first trial number.

The second step is to **apply the calculation plans in the number sentence to the first trial number**. The outcome may or may not be helpful in selecting a second trial number.

For example, $100 - 3 \times 1 = 97$ and $5 \times 1 - 4 = 1$, so it seems that 1 is quite far from the number for which $100 - 3 \times \square$ and $5 \times \square - 4$ will be equal. It hence makes sense to consider a much bigger number.

The third step is to **select a second trial number**. In this case 20 seems a good choice on the basis of the clue that the number should be much bigger than 1.

The fourth step is to **apply the calculation plans in the number sentence to the second trial number**. In this case, $100 - 3 \times 20 = 40$ and $5 \times 20 - 4 = 96$.

The fifth step is to **reflect on the outcomes of the first and second trials** and make a reasoned choice when selecting the third trial number.

In this case, $100 - 3 \times \square$ is bigger than $5 \times \square - 4$ for $\square = 1$, but $100 - 3 \times \square$ is smaller than $5 \times \square - 4$ for $\square = 20$. This suggests that a number between 1 and 20 is required for $100 - 3 \times \square$ to be equal to $5 \times \square - 4$. On the basis of this argument, 10 is an obvious choice as a third trial number.

The process is continued until the solution is found.

10.1 Solve and complete number sentences by trial and improvement

Possible misconceptions

Learners may develop the misconception that when using the trial-and-improvement method, they should correctly guess the solution. If they believe this, they will be inhibited from selecting trial numbers as described on the previous page. It is important that learners develop a “try a number and see what happens” attitude that corresponds to the nature of the trial-and-improvement process.

Notes on questions

It may take learners quite a while to develop the “try a number and see what happens” attitude required for solving number sentences by trial and improvement. Hence questions 1 to 9 all provide some support for their thinking. It is only in questions 10 and 11 (next page) that learners are required to work completely on their own.

Teaching guidelines

Demonstrate the actions in the tinted passage on the board and then let learners continue the process by doing questions 1 and 2. Once they have completed question 2, you may guide them to think as described for the fifth step on the previous page of this Teacher Guide. Some learners may quickly adopt the method and will be able to do question 3 on their own, and then proceed through questions 4 to 11.

Identify learners who get stuck with question 4. Support them (individually or in a group) by taking them through similar steps like those in the tinted passage, and through questions 1 and 2.

Answers

- $100 - 3 \times \text{the missing number} = 5 \times \text{the same number} - 4$
Left-hand side = $100 - 3 \times 10 = 100 - 30 = 70$; Right-hand side = $5 \times 10 - 4 = 50 - 4 = 46$
Therefore, 10 cannot be the missing number because the answers on the right-hand side and left-hand side differ.
- Similar investigations for 20 and 15
- 13
- 13
- (a) $4 \times 20 + 7 = 87$ and $6 \times 20 - 9 = 111$ (not true)
 $4 \times 10 + 7 = 47$ and $6 \times 10 - 9 = 51$ (not true)
 $4 \times 5 + 7 = 27$ and $6 \times 5 - 9 = 21$ (not true)
(b) 10 (c) 5
(d) $4 \times 8 + 7 = 39$ and $6 \times 8 - 9 = 39$ (true)
(e) Various numbers > 8 , e.g. 11; 15; 17; 18 (f) Numbers < 8 , e.g. 7; 6; 4

UNIT

10

NUMBER SENTENCES

10.1 Solve and complete number sentences by trial and improvement

Here is a puzzle to think about:

Hundred minus three times a certain number is equal to four less than five times the number. What is this number?

Can this number be 5?

Mpho investigated:

$$100 - 3 \times 5 = 100 - 15 = 85$$

$$5 \times 5 = 25 \text{ and } 4 \text{ less than } 25 \text{ is } 21.$$

No, 21 is far less than 85!

- Investigate whether the missing number in the puzzle can be 10.
- Investigate whether it can be 20, or maybe 15.
- Find out what the number is!
- Find the number that will make this number sentence true:
 $100 - 3 \times \square = 5 \times \square - 4$
- (a) Investigate whether any of the numbers 20, 10 or 5 will make this number sentence true:
 $4 \times \square + 7 = 6 \times \square - 9$
(b) For which of the three numbers you tried are $4 \times \square + 7$ and $6 \times \square - 9$ closest to each other?
(c) For which of the three numbers you tried is $4 \times \square + 7$ bigger than $6 \times \square - 9$?
(d) Investigate more numbers until you find the number that makes the number sentence true.
(e) Write ten different numbers for which $4 \times \square + 7$ is smaller than $6 \times \square - 9$. (We can also write $4 \times \square + 7 < 6 \times \square - 9$.)
(f) Write three different numbers for which $4 \times \square + 7 > 6 \times \square - 9$.

342

UNIT 10: NUMBER SENTENCES

Teaching guidelines

Recording the different trial numbers and outcomes in a table like the one at the top of the Learner Book page is a very useful way to keep track of the search process.

Mathematical notes

The numerical method (trial-and-improvement method) for solving open number sentences is of substantial mathematical importance: it is the dominant method of solving open number sentences (equations) in modern mathematical practice.

Answers

6. (a) The difference increased again.
 (b) The difference decreased.
7. An example (learners' trial numbers may differ):

Number investigated	5	10	20	15	9	8	7
$40 + 3 \times \square$	55	70	100	85	67	64	61
$10 \times \square - 9$	41	91	191	141	81	71	61
Difference	14	21	91	56	14	7	0

8. An example (learners' trial numbers may differ):

Number investigated	1	5	10	24
$5 \times \square - 12$	-7	13	38	108
$4 \times \square + 12$	16	32	52	108
Difference	23	19	14	0

9. An example (learners' trial numbers may differ):

Number investigated	2	100	50	60
$3 \times \square + 50$	56	350	200	230
$5 \times \square - 70$	-60	430	180	230
Difference	116	80	20	0

10. (a) 60 (b) 60 (c) 60
11. (a) 18 (b) 32 (c) 1

The work that you did in questions 1, 2 and 3 can be recorded in a table like this:

Number investigated	5	10	20	15	13
$100 - 3 \times \square$	85	70	40	55	61
$5 \times \square - 4$	21	46	96	71	61
Difference	64	24	(56)	(16)	0

6. When the number was increased from 5 to 10, the difference between $100 - 3 \times \square$ and $5 \times \square - 4$ decreased from 64 to 24.
- (a) What happened to the difference when the number was increased to 20?
- (b) What happened to the difference when the number was decreased again?
7. Try 5, 10 and other numbers until you find a number for which $40 + 3 \times \square$ is equal to $10 \times \square - 9$.
 Record your work in a table like the above.
8. Try 1, 5 and 10 and other numbers until you find a number for which $5 \times \square - 12 = 4 \times \square + 12$.
 Record your work in a table.
9. Try 2 and 100, and other numbers of your own choice until you find a number for which $3 \times \square + 50 = 5 \times \square - 70$.
10. In each case, find the number that makes the number sentence true.
- (a) $3 \times \square + 100 = 5 \times \square - 20$
 (b) $3 \times \square + 120 = 5 \times \square$
 (c) $120 = 2 \times \square$
- II. In each case, find the number that makes the number sentence true.
- (a) $6 \times \square - 30 = 4 \times \square + 6$
 (b) $200 - 3 \times \square = 5 \times \square - 56$
 (c) $13 \times \square - 5 = 20 - 12 \times \square$

"To increase" means to make bigger and "to decrease" means to make smaller.

10.2 Flow diagrams, number sentences and tables

Mathematical notes

A flow diagram is a way of representing a calculation plan that can be applied to many different numbers. For example, the calculation plan $4 + \square \times 8$ can be represented with this flow diagram:

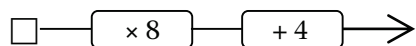

or

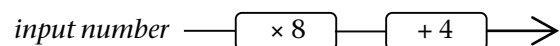

Instead of using the placeholder \square , the flow diagram can be expanded to show that different input numbers are allowed:

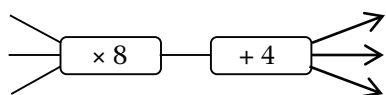

Exactly the same information can also be represented with a **formula**, for example:

$$\text{output number} = 8 \times \text{input number} + 4$$

Answers

- Flow diagram A: $5 \rightarrow 3\ 280$ $2 \rightarrow 1\ 480$ $3 \rightarrow 2\ 080$
- Flow diagram B: $5 \rightarrow 171\ 000$ $2 \rightarrow 169\ 200$ $3 \rightarrow 169\ 800$
- R1 480
- 3 nights
- Number of nights \rightarrow $\times 600$ \rightarrow $+ 280$ \rightarrow Cost

10.2 Flow diagrams, number sentences and tables

- What are the output numbers for the input numbers 5, 2 and 3 in Flow diagram A?



- What are the output numbers for the input numbers 5, 2 and 3 in Flow diagram B?



At the private hospital *Careplace* you have to pay R280 to be admitted, and then R600 for each night that you sleep there.

For example, Thabile was admitted to *Careplace* and stayed for three nights. She had to pay $R280 + 3 \times R600$ which is $R280 + R1\ 800 = R2\ 080$.

- How much do you have to pay if you are admitted to *Careplace* hospital and sleep there for two nights?
- How long was Ben in the hospital if he had to pay R2 080?
- Which of these flow diagrams show how the cost of staying at *Careplace* can be calculated?

Number of nights \rightarrow $+ 280$ \rightarrow $\times 600$ \rightarrow Cost

Number of nights \rightarrow $\times 600$ \rightarrow $+ 280$ \rightarrow Cost

Here is another way to describe how you can calculate the cost of staying in the private hospital *Careplace*:

Cost = $600 \times \text{the number of nights} + 280$, or

Cost for \square nights = $600 \times \square + 280$

Teaching guidelines

The section as a whole comprises an investigation to establish under which circumstances a certain hospital will be cheaper than another hospital. It amounts to answering the following question:

For which values of \square is $600 \times \square + 280$ smaller than $620 \times \square + 100$?

Answers

6. (a) R3 880 (b) R7 480
 7. (a) R3 820 (b) R7 540
 8. For a longer stay, *Careplace* is cheaper; for a shorter stay, *Goodcare* is cheaper.

Number of nights	1	2	3	4	5
<i>Careplace</i>	880	1 480	2 080	2 680	3 280
<i>Goodcare</i>	720	1 340	1 960	2 580	3 200
<i>Thulare</i>	960	1 460	1 960	2 460	2 960

6	7	8	9	10	11	12
3 880	4 480	5 080	5 680	6 280	6 880	7 480
3 820	4 440	5 060	5 680	6 300	6 920	7 540
3 460	3 960	4 460	4 960	5 460	5 960	6 460

10. For fewer than 9 nights, *Goodcare* works out cheaper, but for more than 9 nights, *Careplace* is cheaper.
 11. (a) R460
 (b) Cost = $500 \times \text{the number of nights} + 460$

6. Calculate the total cost for admission and accommodation at the *Careplace* private hospital for
 (a) 6 nights (b) 12 nights

At *Goodcare* private hospital the admission cost is R100 and the rate for one night is R620.

7. Calculate the total cost for admission and accommodation at the *Goodcare* private hospital for
 (a) 6 nights (b) 12 nights
 8. Which hospital do you think is cheaper, *Careplace* or *Goodcare*? Explain your answer.
 9. Make a table like this to show the costs of staying in the *Careplace* or *Goodcare* hospitals. The costs for *Thulare*, a third hospital, are also shown in the table below.

Number of nights	1	2	3	4	5
<i>Careplace</i>	880	1 480	2 080		
<i>Goodcare</i>					
<i>Thulare</i>	960	1 460	1 960	2 460	2 960

6	7	8	9	10	11	12
3 460	3 960	4 460	4 960	5 460	5 960	6 460

10. When you have completed your table for question 9, look again at question 8 and at your answer. You may now give a better answer if you want to.
 11. (a) What is the admission fee and the daily rate at *Thulare*?
 (b) Using a flow diagram or another method, describe how the cost of staying at *Thulare* can be calculated.

Learner Book Overview		
Sections in this unit	Content	Pages in Learner Book
11.1 A coin-tossing experiment	Investigate what happens for many events if there are two equally likely outcomes	346 to 347
11.2 Spinner Experiment 1	More experiments with and reflection on events with two equally likely outcomes	347 to 348
11.3 Spinner Experiment 2	Repeating an event with outcomes that are not equally likely	349

CAPS time allocation	2 hours
CAPS page references	31 and 208

Mathematical background

When a coin is tossed, one of two things can happen. Stated differently, there are two possible outcomes: the coin can come to rest on one side or on the other side. The terms “heads” and “tails” are often used to distinguish the two sides of a coin. When a normal coin is tossed many times, there is no reason to expect that the one outcome (heads) will occur more often than the other outcome (tails). We say the two possible outcomes are “equally likely” – this is a way of saying that one would expect more or less the same number of heads and tails if a coin is tossed many times. The same applies to the rolling of a die, though in this case there are six different equally likely outcomes.

When a coin is tossed (or when a die is rolled) once, it is impossible to predict with any confidence what the outcome of the event will be. Although the range of possible outcomes is known, no grounds exist to predict that one outcome rather than another will occur. Any of the outcomes is exactly as likely to occur as any other. Hence the outcome of the event is **unpredictable**. Such events are called **random events**.

Although the outcome of a random event is completely unpredictable, predictions can be made about approximately how often a particular outcome will occur if the event is repeated many times. For example, if a coin is tossed many, many times, it will end up on one side for about half of the time and on the other side for about half of the time. If an ordinary die is rolled many, many times, the number 4 (or any other number in the range 1, 2, 3, 4, 5, 6) can be expected to occur roughly one sixth of the time. Suppose another die is not marked 1, 2, 3, 4, 5, 6 on its six faces, but red on one face, blue on two faces and yellow on three faces. If such a coloured die is rolled many, many times, red can be safely predicted to come on top about 1 sixth of the time, blue to come on top roughly one third of the time and yellow to come on top roughly half of the time.

The activities in this unit provide learners with experiences of repeated **random events**, with a view for them to experience that the different possible outcomes happen **approximately** the same number of times.

Resources

Coins; cardboard for making spinners; scissors; sheets of A4 paper; red and blue colouring pencils or crayons

Note: To save classroom time, it will be better if you make the spinners and coloured sheets required for Sections 11.2 and 11.3 for your learners.

11.1 A coin-tossing experiment

Mathematical notes

Random events (“probability”) can be investigated **theoretically**, by arguing logically. For example, one may **argue** that if a die is rolled many times, roughly the same number of each of the six different possible outcomes may occur. Random events can also be investigated **empirically**, by **performing** the events repeatedly and **analysing the actual outcomes**. Learners are engaged in both theoretical and empirical investigations of random events in this unit.

In question 1, learners are invited to think theoretically about tossing a coin. In question 2 they engage empirically with the same questions.

Tallies are indicated by drawing a line for every occurrence. Every fifth line crosses the four preceding lines so that five lines can easily be counted. Counting the tallies gives the **frequencies**, which are expressed as numbers, for example 11 and 9.

Teaching guidelines

It may be necessary to explain the meaning of question 1(a) to learners. It means: “If you toss the coin 20 times, how many times do you think it will land on the one side, and how many times do you think it will land on the other side?”

The purpose of questions 1 and 2 is to allow learners to develop a sense of what happens when a random event is repeated many times: the different outcomes happen approximately the same number of times, but not necessarily exactly the same number of times. Learners are not expected to produce any specific explanations in questions 1(c) and 2(b); the purpose of these questions is only to induce them to think about what may happen when a random event is repeated many times.

Notes on questions

The purpose of question 1 is not to assess whether learners know supposedly correct answers. The purpose is to entice the learners into making a prediction (hypothesis), which they will then investigate in questions 2 and 3.

Answers

- (a) to (c) Learners who suggest that heads and tails are equally likely as results and hence that heads and tails should each come up more or less half the time, demonstrate good intuitions about random events.
- (a) Answers will vary, but the fractions closer to $\frac{10}{20}$ are more likely.
(b) Individual results. Learners will probably have different results. No, any specific result is unlikely because any two learners are unlikely to get the same result.

UNIT

11

PROBABILITY

11.1 A coin-tossing experiment

- Imagine you toss a coin many times. You check every toss to see if it is “heads” or “tails”.
 - Write down what you think the results will be when you toss a coin 20 times.
 - How many “heads” do you think you will get if you toss the coin many, many times?
 - How many “tails” do you think you will get if you toss the coin many, many times? Explain why you say so.

A coin has two sides. The “tail” side of a coin is the side that says what the coin is worth. The “head” side is the side with the country’s coat of arms. A coin toss has **two outcomes**, either “heads” or “tails”.

- Work with a classmate to do the coin-tossing experiment. Record your results in a tally table.
Each of you must toss the coin 20 times. At the end you should have the result of your 20 tosses, and your classmate should have the result of his or her 20 tosses.

Frequency means how often a certain outcome has occurred; in this case, how many times you got “heads” and how many times you got “tails”.

	Tallies	Frequency
Heads		
Tails		

- What fraction of *your* 20 results is “heads” ($\frac{?}{20}$)? Did your experiment work out the way you thought it would? Explain why you say so.
- What fraction of *your classmate’s* 20 results is “heads” ($\frac{?}{20}$)? Do you think there is a problem with the experiment if your results are very different? Explain why you say so.

Answers

3. (a) and (b) Answers will differ. The results will be in eightieths. It should be fairly close to 40 heads and 40 tails. The more times the coin is tossed, the more likely it is that the distribution will be close to 50% heads and 50% tails.
- (c) Individual answers. The purpose of the question is only to induce learners to think about what may happen when a random event is repeated many times.

11.2 Spinner Experiment 1

Teaching guidelines

To save classroom time, it would be best if you make the spinners and colour the sheets beforehand.

Shorter pencils work better. The pencil should be inserted perpendicularly (at 90 degrees) through the centre of the cardboard square. The centre is at the point where the diagonals (lines connecting opposite corners) cross.

During the experiment one of the sides of the cardboard square will end up touching the page. The midpoints of the sides are indicated by dots/marks. The colour on which the dot/mark lands, is the result (outcome) of the spin.

Approximately equal numbers of blue and red landings will be obtained.

A typical tally table for 20 spins will look like this:

Red	Blue

3. You recorded 20 tosses and your classmate recorded 20 tosses. Put your results together with those of two other classmates, so that you have the results of 80 tosses altogether.
- (a) What fraction of the results is “heads”?
- (b) What fraction of the results is “tails”?
- (c) Are you surprised by the results? Explain why you say so.

11.2 Spinner Experiment 1

Make your own spinner

Look at the picture. Take a square piece of cardboard and make a hole in the centre. Put your pencil through the hole. Then make a dot or mark at the centre of each of the sides of the square.

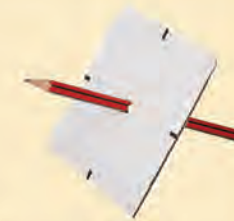

Make sure you have paper to record your results in tally tables and to draw graphs.

Practise spinning your spinner properly at a fast speed. When the spinner stops and topples over, the dot on the side on which the spinner comes to rest gives the position of the spinner.

Fold a clean page in half, and crosswise in half again. Open up the page. It now has *four* parts of equal size.

Mark the central point, that is, the point where the folds intersect. Colour two of the four parts red (or just write RED in them). Colour the other two parts blue (or just write BLUE in them).



Put your spinner on the central point of the page and spin it properly. Note whether the dot lands on a blue or a red part of the page. Spin the spinner 20 times. Each time write down the result of the spin (outcome) in a tally table.

Teaching guidelines

Explain to learners that the phrases “outcomes of Spinner Experiment 1” in question 1(d) and “results of Spinner Experiment 1” in question 2 refer to the combination of all 20 outcomes – one outcome each time the spinner is spun.

The purpose of questions 1 to 3 is again to allow learners to develop a sense of what happens when a random event is repeated many times: the different outcomes happen approximately the same number of times, but not necessarily exactly the same number of times.

Answers

- Yes. If you put the spinner in the middle of one of the quarters of the page, it might end up in that quarter more often. We put the spinner in the centre to make the chances even.
 - No, as long as it goes around enough times.
 - No, it will not matter. The area hasn't changed, therefore red and blue are still equally likely as results.
 - Red and blue could be divided respectively 20-0 (very, very unlikely), 19-1, 18-2, 17-3, 16-4, 15-5, 14-6, 13-7, 12-8, 11-9, 10-10, 9-11, 8-12, 7-13, 6-14, 5-15, 4-16, 3-17, 2-18, 1-19 or 0-20 (very, very unlikely).
- Individual results. The fractions will vary between $\frac{0}{20}$ (“0 out of 20”) and $\frac{20}{20}$. Fractions close to $\frac{10}{20}$, like $\frac{9}{20}$, $\frac{11}{20}$, $\frac{8}{20}$ and $\frac{12}{20}$, will occur more often than fractions further away from $\frac{10}{20}$, like $\frac{5}{20}$ and $\frac{16}{20}$.
- to (c) A typical distribution for 45 learners might look like this:

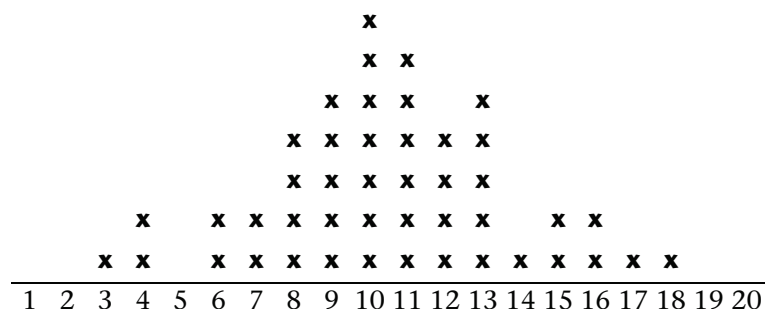

- Think about Spinner Experiment 1.
 - Do you think the results could be influenced by where you place the spinner when you start to spin?
 - Do you think your experiment could be influenced by how slow or fast you spin the spinner?
 - Will it matter if the parts are coloured in such a way that the two red parts (areas) are next to each other and the two blue parts are next to each other? Why do you say so?
 - What are the possible outcomes of Spinner Experiment 1?
- Compare your data (that is, the results of Spinner Experiment 1) with that of other classmates. What fraction of the 20 spins in their experiments was RED?
- Work with the rest of the class. Use the information in your tally tables to make a pictograph to show how many REDS each classmate got out of 20 spins.
 - Draw a number line in your book that runs from 0 to 20. Nobody will be able to get more than 20 REDS in 20 spins.
 - As each learner says how many REDS he or she got, make a cross above that number.
 - Write a short paragraph about the story of the graph.

Sometimes people think the number of RED results and the number of BLUE results must be the same in any experiment, because the page is divided into two equal parts. This is not true.

Only when we do an experiment with many, many spins can we expect to see *almost* the same number of RED and BLUE results if the page is divided into two equal parts. We cannot expect that in small experiments.

11.3 Spinner Experiment 2

Mathematical notes

The chances that the spinner will land on any of the four quarters are equal. However, because three of the quarters are now red, one would expect the spinner to land on red approximately 3 out of every 4 times.

Answers

- For every spin, red and blue are the possible outcomes. The possible outcomes for 20 spins range from 0 out of 20 red to 20 out of 20 red (or blue).
 - Hopefully learners will argue that since 3 of the 4 equally likely outcomes are now red, the outcome of Spinner Experiment 2 will be different. The spinner can be expected to land on red about 3 times as often as on blue.
- A group of five will have data of 100 spins.
 - Group answer in hundredths

11.3 Spinner Experiment 2

Fold a clean page in half, and crosswise in half again. Your page now has four parts of equal size.

Open the page up and mark the point where the folds intersect.

Colour three of the four parts red (or just write RED in them).

Colour the remaining part blue (or just write BLUE in it).



- Before you start, first think about the experiment.
 - What are the possible outcomes of Spinner Experiment 2?
 - Do you think the results will be similar to your results for Spinner Experiment 1? Why do you say so?
- Now do Spinner Experiment 2. Put your spinner at the centre of the page and spin it properly. Note whether the dot lands on a blue or a red part of the page.

Spin the spinner 20 times. Each time record the result of the spin in a tally table.

 - Combine your data with the data of four classmates so that you have 100 results.
 - What fraction of the 100 results was RED? What fraction was BLUE?

Addendum

General resources

Place value cards for learners	394
Place value cards for teachers	398
Square grid paper (1 cm × 1 cm)	412
Graph paper / Square grid paper (0,5 cm × 0,5 cm)	413
Graph paper	414
Dotted paper	415
A model for teaching conversion of units	416
Rulers	417

Resources for specific activities

Term 1 Unit 6: Section 6.4, question 5	417
Term 1 Unit 6: Section 6.4, question 7	418
Term 2 Unit 5: Section 5.1, question 1	419
Term 2 Unit 5: Section 5.1, question 3	420
Term 4 Unit 3: Section 3.2, question 2	421
Term 4 Unit 3: Section 3.2, question 4	422
Term 4 Unit 4: Section 4.2, question 1	423
Term 4 Unit 4: Section 4.3, question 1	424
Term 4 Unit 5: Section 5.3, Additional learning activity	425
Term 4 Unit 7: Section 7.1, question 1	425
Term 4 Unit 6: Section 6.2, question 1	426

100

10000

2000

90

80

1

3000

70

60

2

4000

50

40

Place value cards
for learners
(4 pages = 1 set)

500

30

20

3

600

10

4

5

6

700

1000

7

800

900

8

9

20000

30000

40000

50000

60000

70000

80000

90000

200000

300000

400000

500000

600000

700000

800000

900000

1000

Place value cards
for teachers

(14 pages = 1 set)

100

10

2000

20

3000

30

4000

400

5000

500

6000

600

7000

700

8000

800

9000

900

2000

1

3000

2

40000

3

50000

4

60000

5

70000

6

8000

7

9000

8

10000

20000

30000

40000

5 0 0 0 0

6 0 0 0 0

7 0 0 0 0

8 0 0 0 0

90000

9

Square grid paper (1 cm × 1 cm)

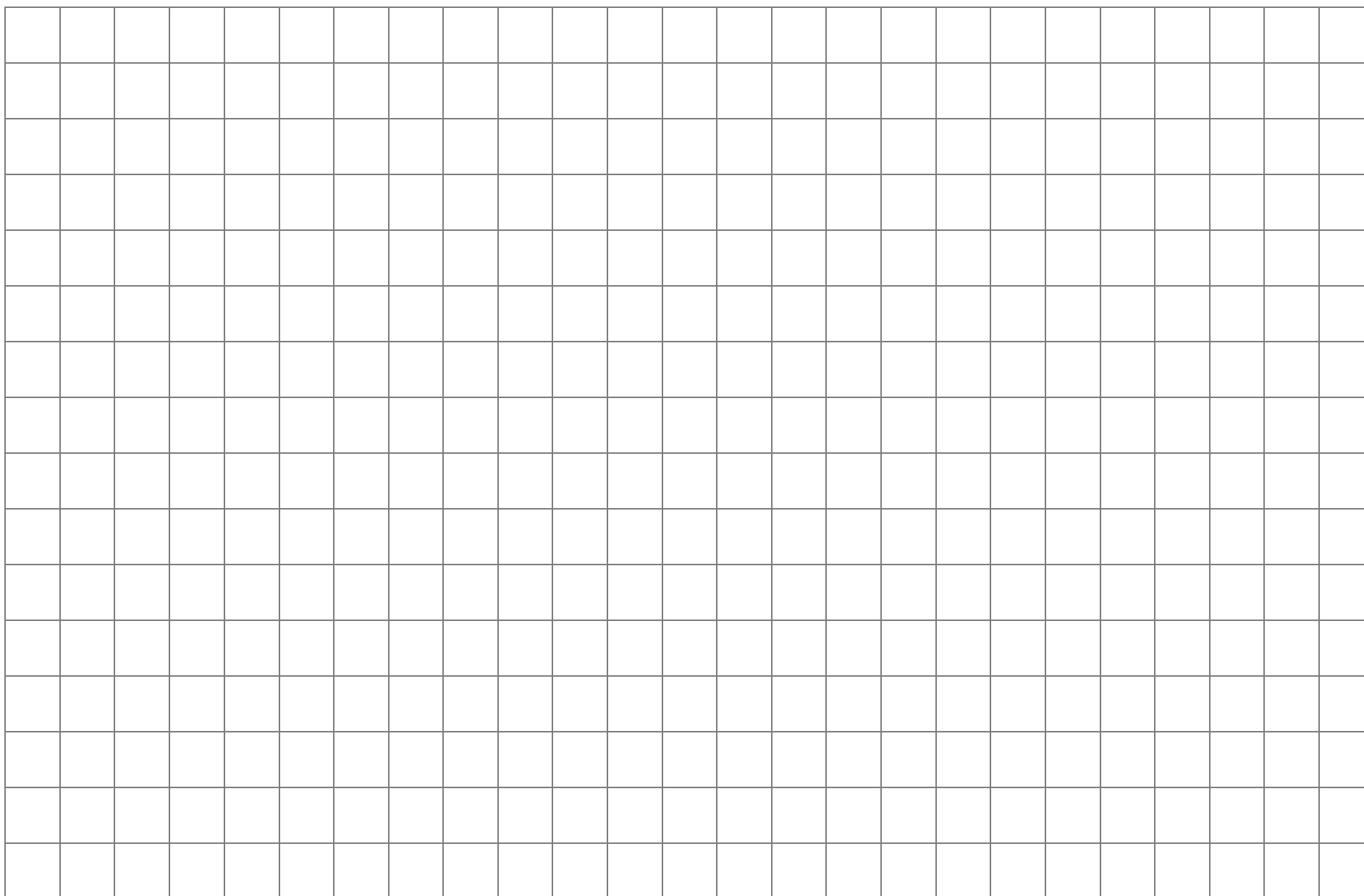

Graph paper / Square grid paper (0,5 cm × 0,5 cm)

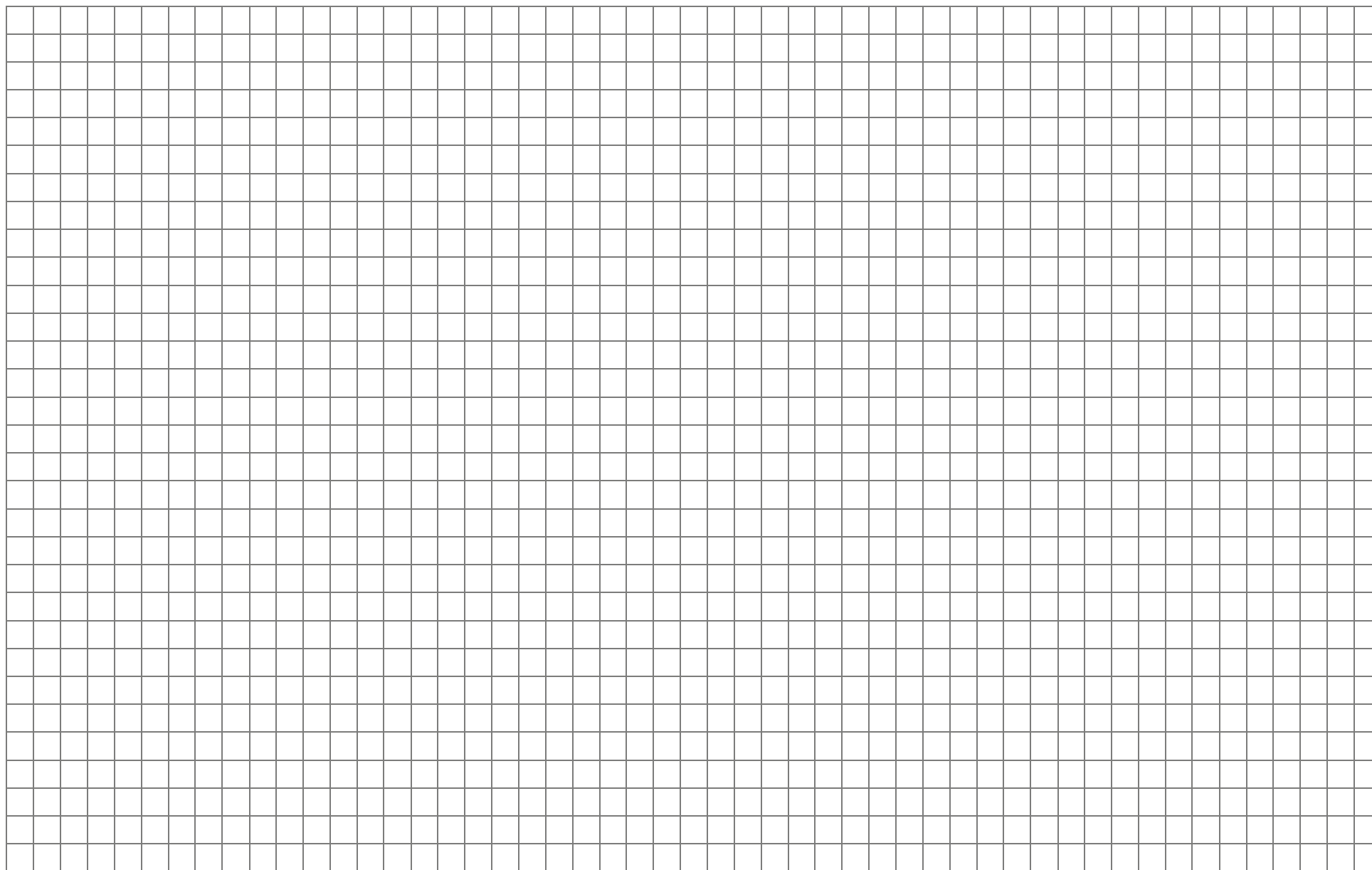

Graph paper



Dotted paper

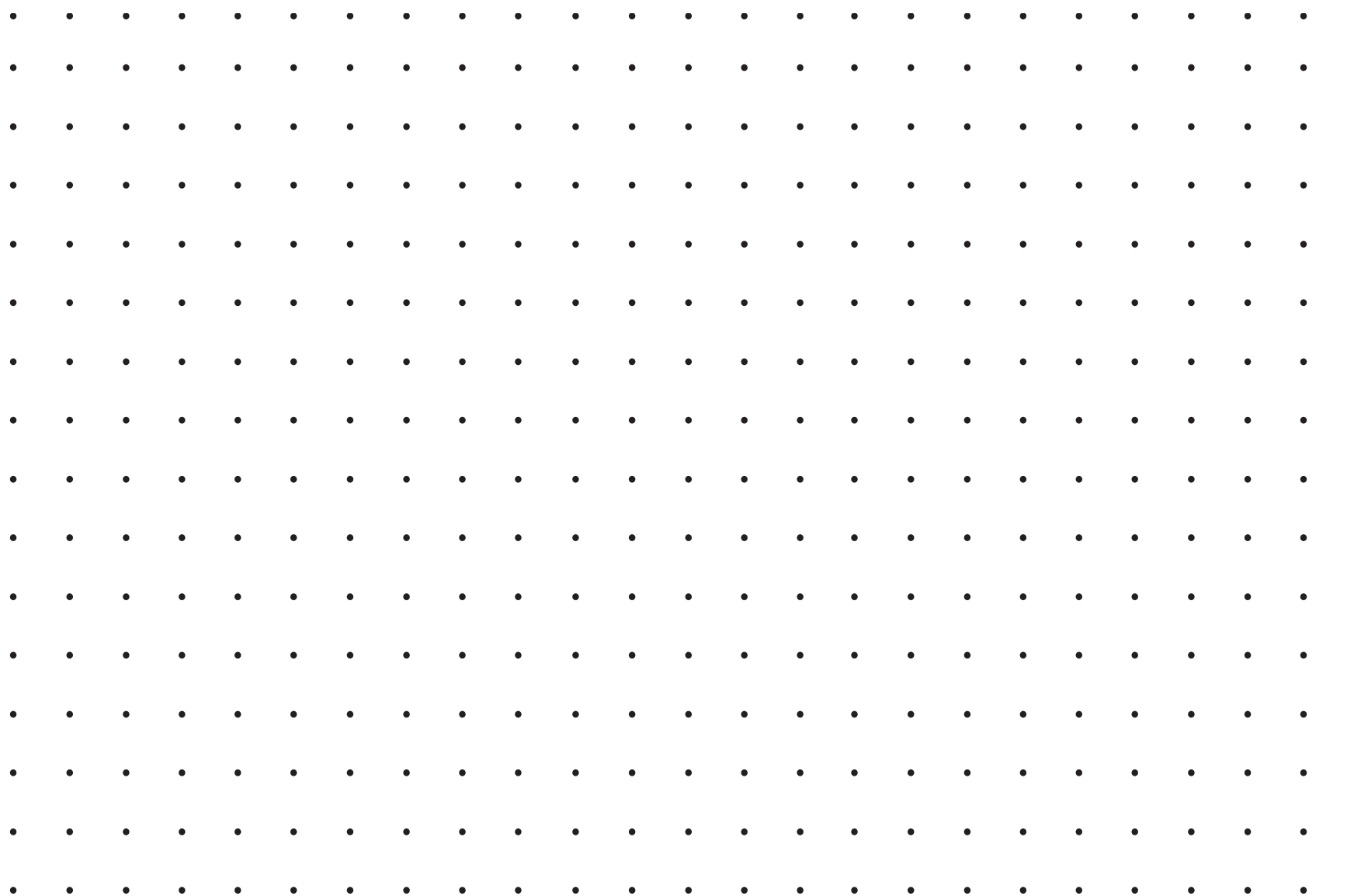

A model for teaching conversion of units (TG pp. 117, 162, 235)

“The purpose of this remediation is to provide guidance on minimising errors on conversions. Emphasis should be placed on practical demonstrations to show the relationship between different units of measurement.

The following steps could be used to remedy the problems encountered in conversions of units. When teaching conversions, emphasis must be placed on multiplication by a thousand since ‘kilo’ means thousand and ‘milli’ means one thousandth.

The following model may be used to teach conversion of units:

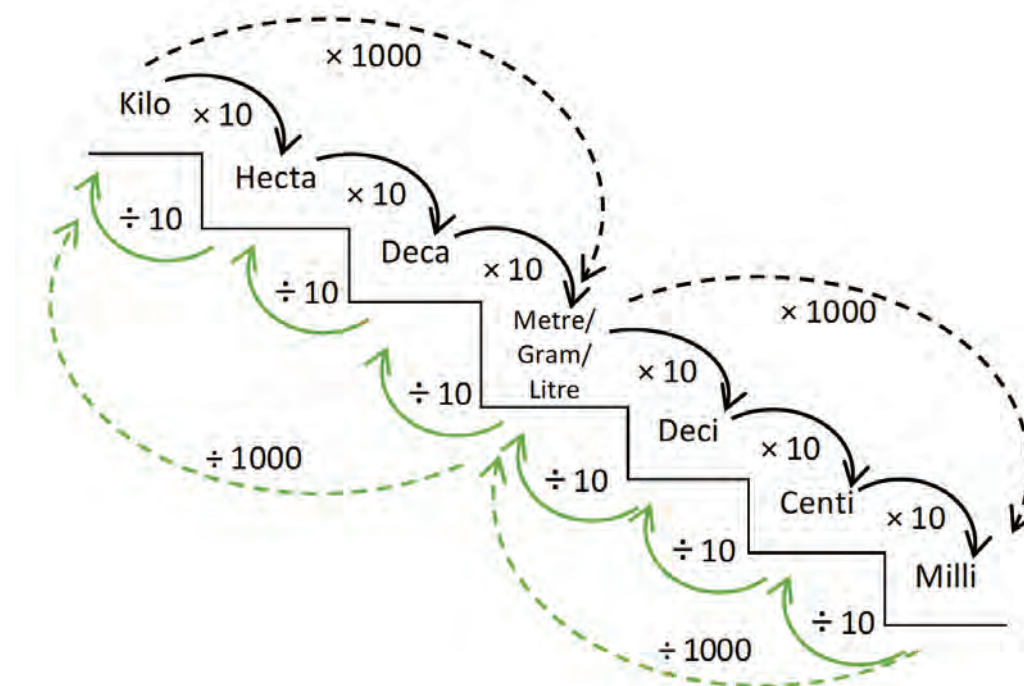

The model shows intervals of milli (grams/litres/metres) up to kilo (grams/litres/metres). The intervals range in units of tens, for example converting from centi to milli, one would need to multiply by ten and from milli to centi one would need to divide by ten; thus 1 centimetre = 10 millimetres and 1 millimetre = 0,1 centimetre. Similarly, it is noticeable in the model that from kilo to the basic unit (metre/litre/gram) one needs to multiply by a thousand and vice versa; thus 1 kilogram = 1 000 grams and 1 000 grams = 0,001 kilogram.

The following mnemonic may be used for learners to remember the order of the units of measurement: Kids Have Dreams Making Dad Chocolate Muffins.”

Extract from: DBE (2015). *Annual National Assessment of 2014. Diagnostic report. Intermediate and Senior Phases. Mathematics*. Government Printers. Pretoria, p. 37

Rulers

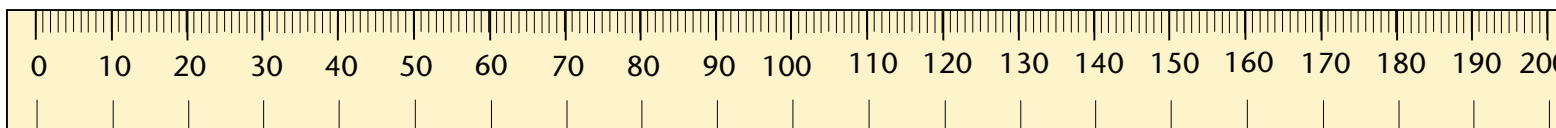
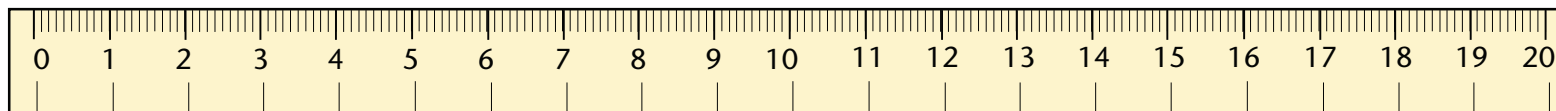

Term 1 Unit 6: Section 6.4, question 5 (TG p. 79; LB p. 73)

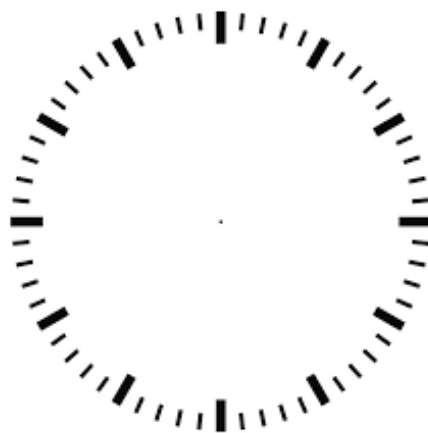
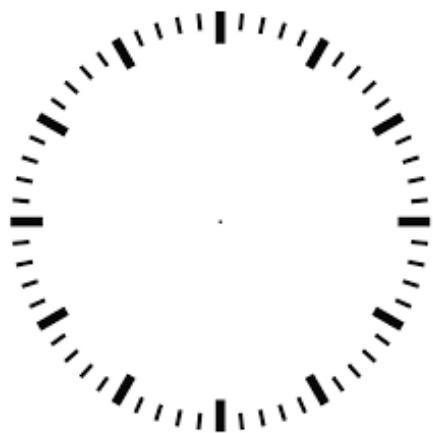

Term 1 Unit 6: Section 6.4, question 7 (TG p. 79; LB p. 73)

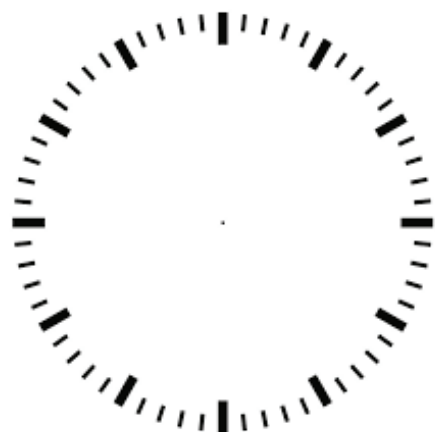
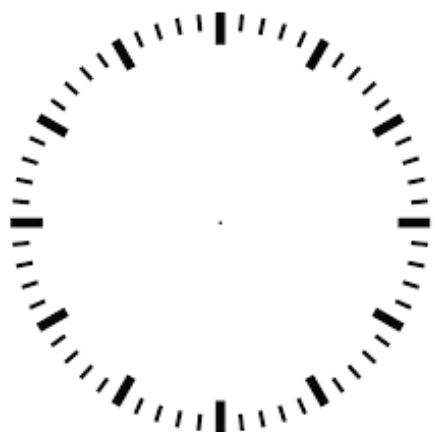
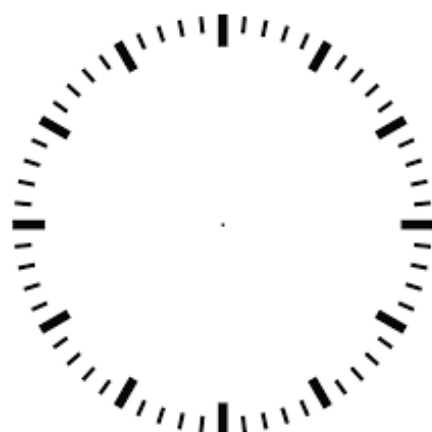
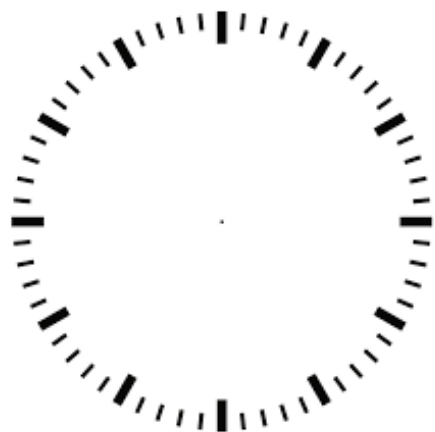

Term 2 Unit 5: Section 5.1, question 1 (TG p. 171; LB p. 157)

$30 \times 8 =$	$30 \times 10 =$	$30 \times 2 =$	$30 \times 5 =$	
$70 \times 7 =$	$70 \times 8 =$	$70 \times 10 =$	$70 \times 2 =$	
$80 \times 6 =$	$80 \times 7 =$	$80 \times 8 =$	$80 \times 10 =$	
$50 \times 4 =$	$50 \times 6 =$	$50 \times 7 =$	$50 \times 8 =$	
$20 \times 9 =$	$20 \times 4 =$	$20 \times 6 =$	$20 \times 7 =$	
$90 \times 3 =$	$90 \times 9 =$	$90 \times 4 =$	$90 \times 6 =$	
$60 \times 5 =$	$60 \times 3 =$	$60 \times 9 =$	$60 \times 4 =$	
$40 \times 2 =$	$40 \times 5 =$	$40 \times 3 =$	$40 \times 9 =$	
$10 \times 10 =$	$10 \times 2 =$	$10 \times 5 =$	$10 \times 3 =$	
$30 \times 3 =$	$30 \times 9 =$	$30 \times 4 =$	$30 \times 6 =$	$30 \times 7 =$
$70 \times 5 =$	$70 \times 3 =$	$70 \times 9 =$	$70 \times 4 =$	$70 \times 6 =$
$80 \times 2 =$	$80 \times 5 =$	$80 \times 3 =$	$80 \times 9 =$	$80 \times 4 =$
$50 \times 10 =$	$50 \times 2 =$	$50 \times 5 =$	$50 \times 3 =$	$50 \times 9 =$
$20 \times 8 =$	$20 \times 10 =$	$20 \times 2 =$	$20 \times 5 =$	$20 \times 3 =$
$90 \times 7 =$	$90 \times 8 =$	$90 \times 10 =$	$90 \times 2 =$	$90 \times 5 =$
$60 \times 6 =$	$60 \times 7 =$	$60 \times 8 =$	$60 \times 10 =$	$60 \times 2 =$
$40 \times 4 =$	$40 \times 6 =$	$40 \times 7 =$	$40 \times 8 =$	$40 \times 10 =$
$10 \times 9 =$	$10 \times 4 =$	$10 \times 6 =$	$10 \times 7 =$	$10 \times 8 =$

Term 2 Unit 5: Section 5.1, question 3 (TG p. 172; LB p. 158)

×	2	4	8	3	6	5	10	9	7
10									
50									
90									
80									
40									
20									
30									
60									
70									

Term 4 Unit 3: Section 3.2, question 2 (TG p. 329; LB p. 294)

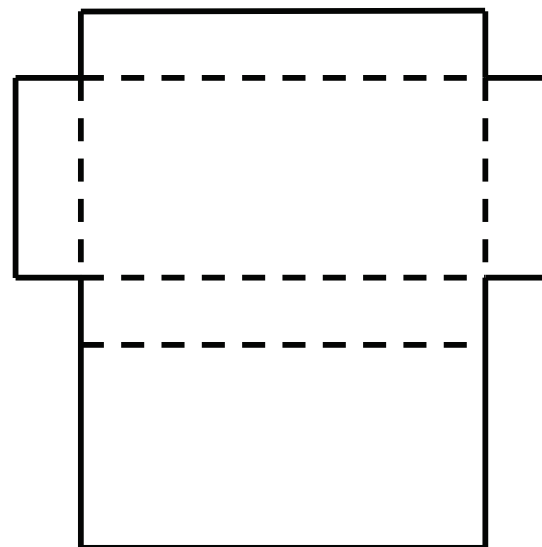
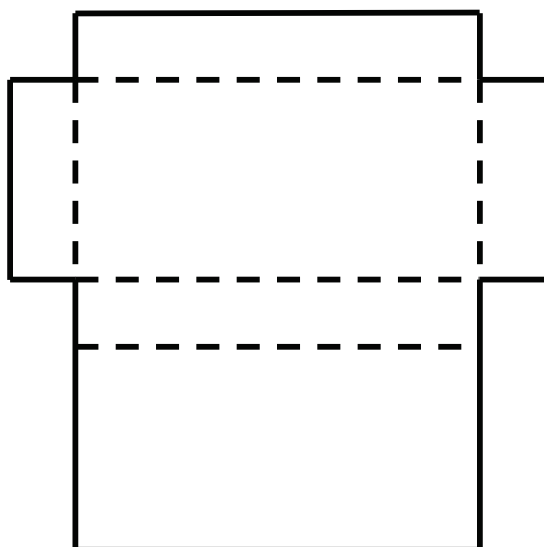
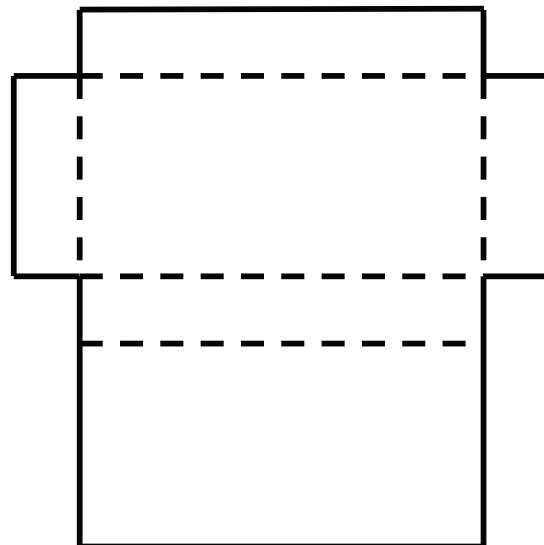
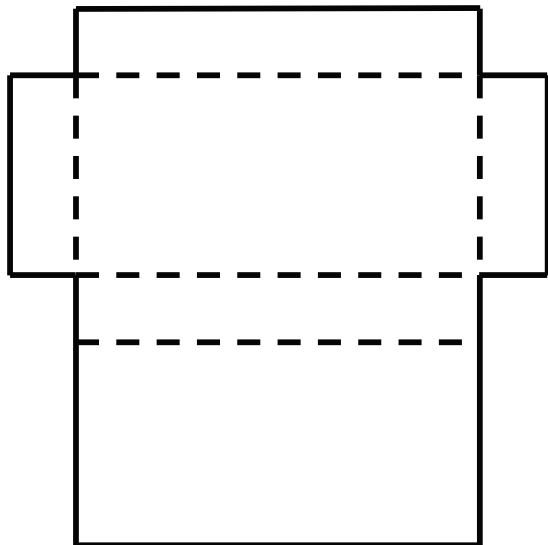

Term 4 Unit 3: Section 3.2, question 4 (TG p. 330; LB p. 295)

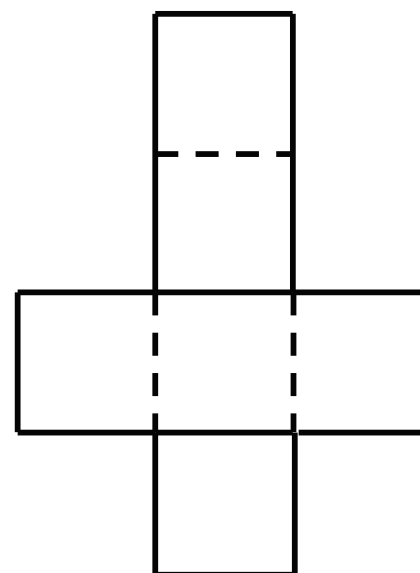
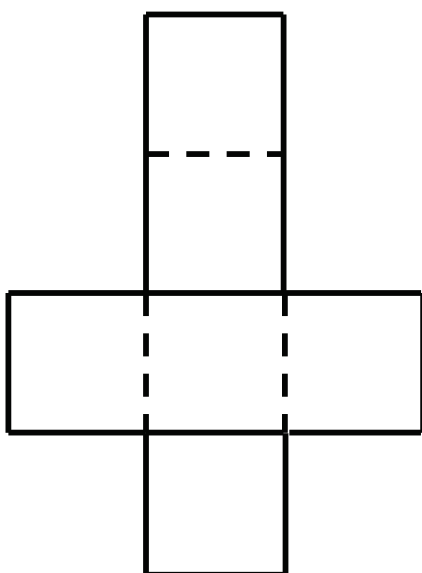
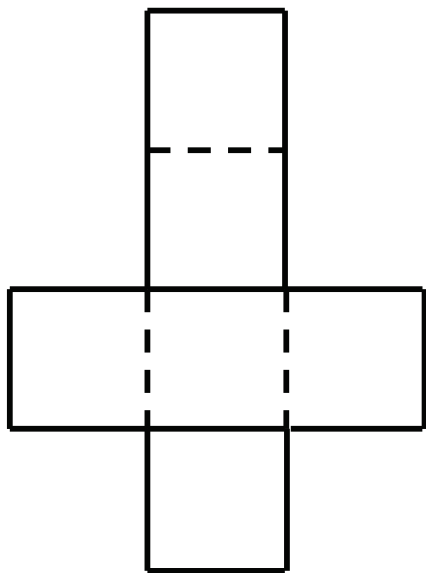
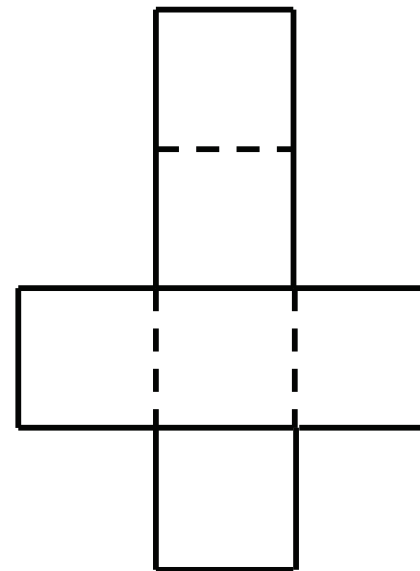
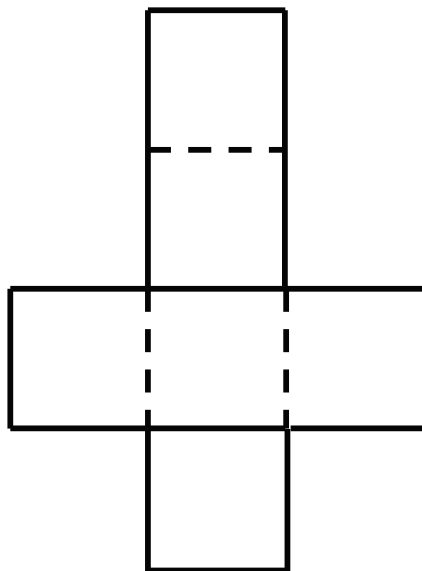
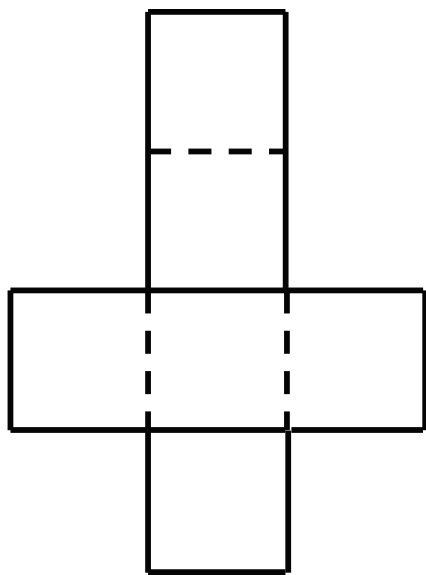

Term 4 Unit 4: Section 4.2, question 1 (TG p. 340; LB p. 304)

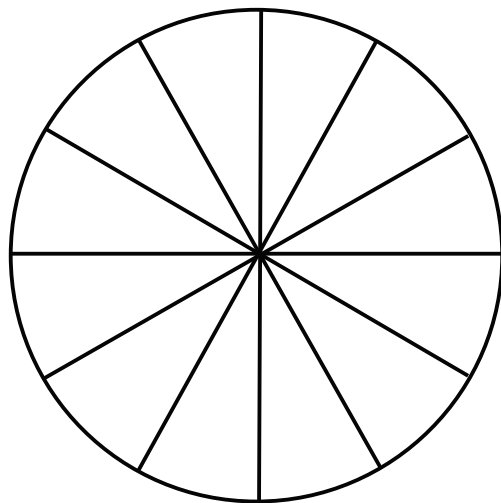
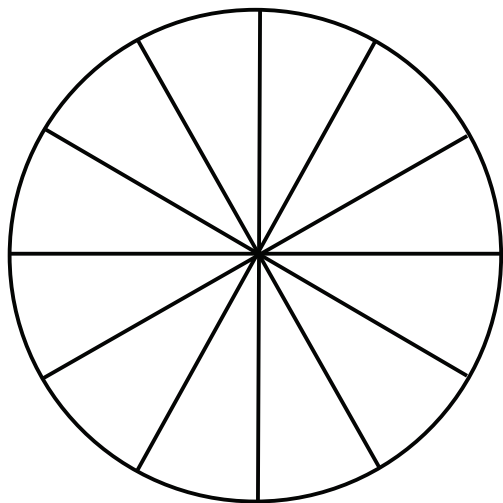
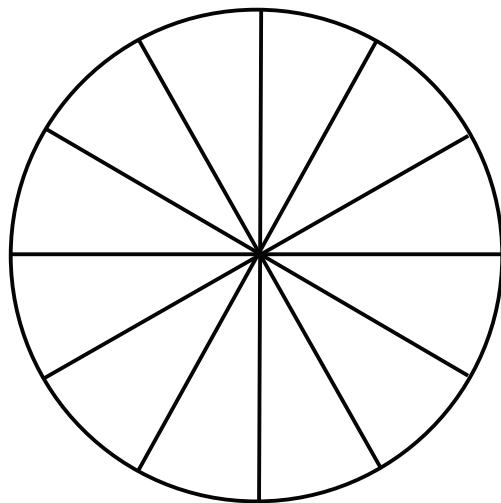
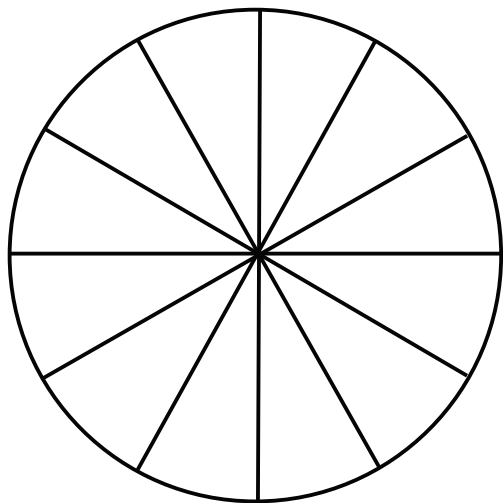

Term 4 Unit 4: Section 4.3, question 1 (TG p. 342; LB p. 306)

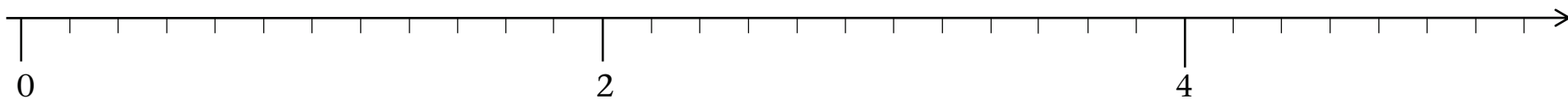
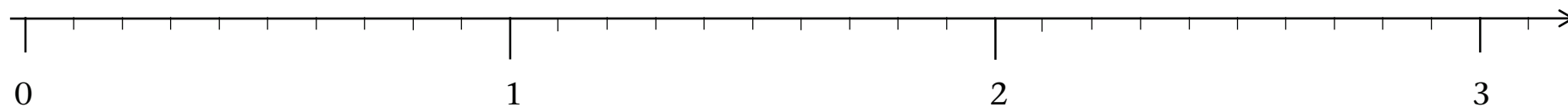
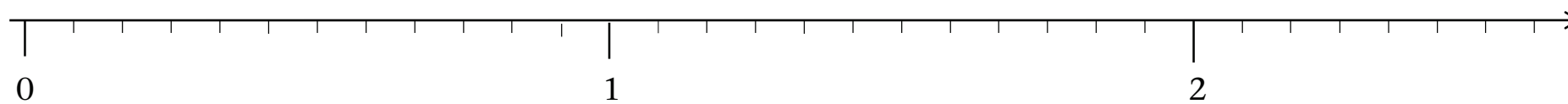
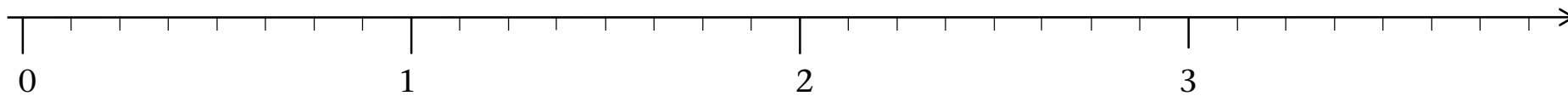

Term 4 Unit 5: Section 5.3
 Additional learning activity (TG p. 351)

Which of the rectangles below are enlargements or reductions of the shaded rectangle?

In each case, explain why you think it is, or why it is not.

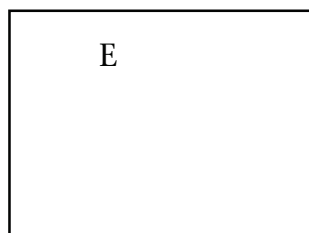
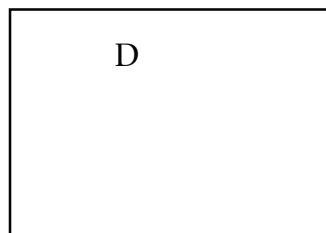
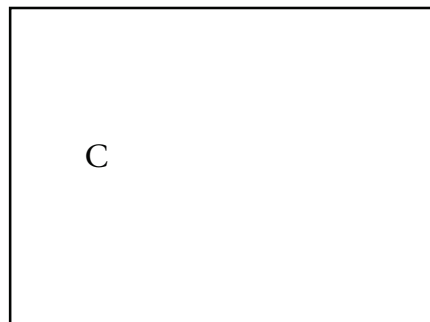
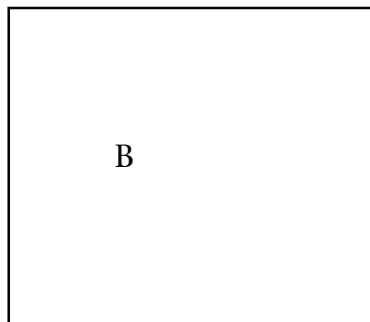
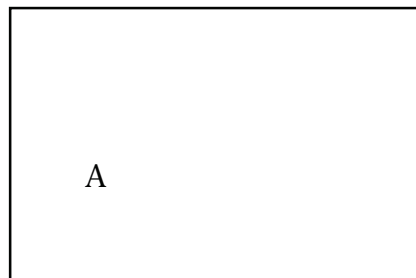
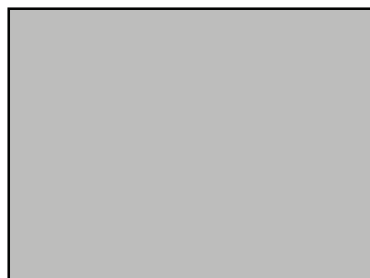

Term 4 Unit 7: Section 7.1, question 1
 (TG p. 370, LB p. 331)

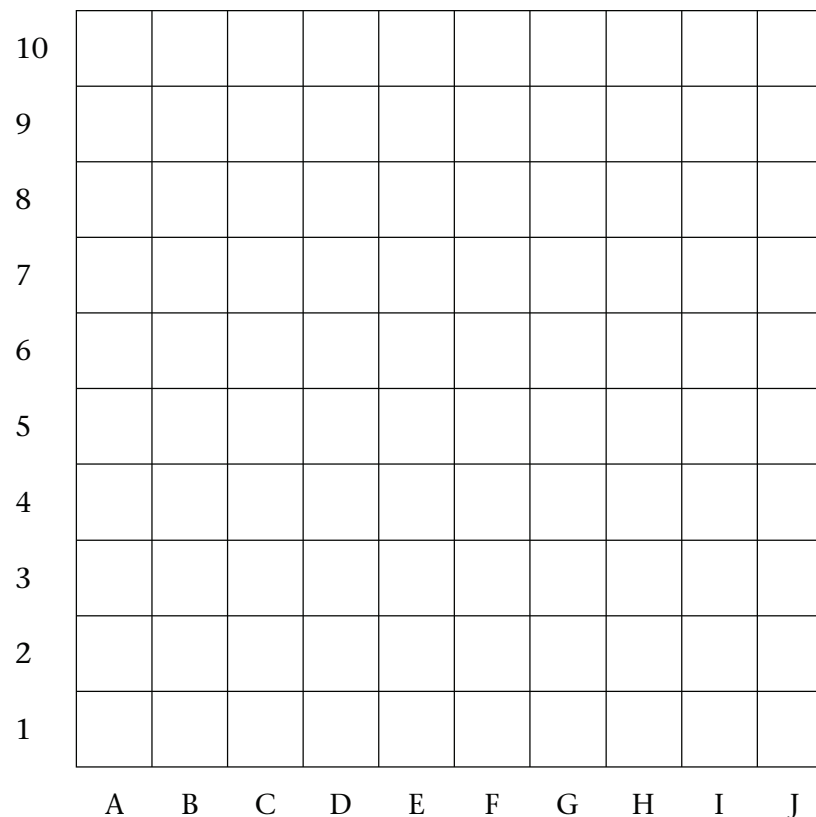

Term 4 Unit 6: Section 6.2, question 1 (TG p. 360; LB p. 323)

