

Everything Science for Grade 10

Teacher's Guide

An Introduction to using Everything Science for Grade 10

Written by Volunteers



ISBN: 978-1-920423-09-4



basic education
Department:
Basic Education
REPUBLIC OF SOUTH AFRICA



SHUTTLEWORTH
FUNDED

Copyright Notice

Your freedom to legally copy this book

You are allowed and encouraged to freely copy this book. You can photocopy, print and distribute it as often as you like. You can download it onto your mobile phone, iPad, PC or flash drive. You can burn it to CD, e-mail it around or upload it to your website.

The only restriction is that you have to keep this book, its cover and short-codes unchanged.

For more information about the Creative Commons Attribution-NoDerivs 3.0 Unported (CC BY-ND 3.0) license see <http://creativecommons.org/licenses/by-nd/3.0/>

Contributors list

Siyavula core team

Mark Horner; Heather Williams; Bridget Nash



More than a regular school textbook



Everything Science is not just a Physical Science textbook. Even though it has everything you expect from a printed school textbook, it comes with a whole lot more! For a start, your learners can download it or read it on-line on their mobile phone, computer or iPad, which means everyone has the convenience of accessing it wherever they are.

It is good for learners to hear and read different explanations of concepts as it affords them a more well-rounded understanding of the work. This is why every chapter comes with links to on-line video lessons and explanations, which help bring the ideas and concepts covered to life. Summary presentations at the end of every chapter offer an overview of the content covered, with key points highlighted for easy revision.

All the exercises inside the book link to an on-line service where learners can get more practice, see the full solutions or test their skills level on mobile and PC. Every educator knows that the key to success in physical science is practice, practice, practice!

We are interested to know what you as an educator think about our books, as well as what the learners wonder about or struggle with as they make their way through the content and attempt the exercises. That is why we have made it possible for educators and learners to use their mobile phones or computers to access the books on-line and digitally pin a question to a page and see what questions and answers other readers pinned up too.

Read it on your mobile or PC

Learners can have this textbook at hand wherever they are – whether at home, on the the train or at school. They can browse the on-line version of *Everything Science* on their mobile phone, tablet or computer. To read it off-line, a PDF or e-book version can be downloaded. Learners can access *Everything Maths* and *Everything Science* for Grade 10, 11 and 12 on their mobile phone! There is now no excuse for a learner to not have these textbooks close at hand!

To read or download the textbook on their phone or computer, direct learners to www.everythingscience.co.za

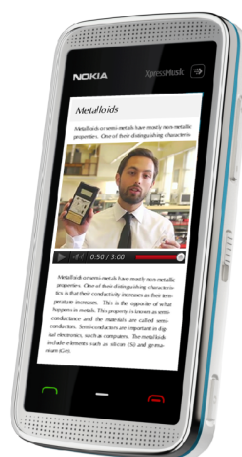

Links to support materials

Inside the textbook you will find these icons to help you and your learners spot where on-line videos, presentations, practice tools and additional help exists. The short-codes next to the icons allow both educators and learners to navigate directly to the resources on-line without having to spend time searching for them. Visit www.everythingscience.co.za and enter the short-codes in the navigation box.



(A123) – Go directly to a section



(V123) – Video, simulation or presentation



(P123) – Practice and test your skills



(Q123) – Ask for help or find an answer

Video lessons

Look out for the video icons inside the book. These will take you to on-line video lessons that help bring the ideas and concepts on the page to life. Learners can now get extra insight, detailed explanations and worked examples, while also seeing the concepts in action and hearing real people talk about how they use maths and science in their work! Included in this are the interactive PhET Simulations, which offer an interactive and accurate representation of physics and chemistry concepts, allowing learners to manipulate the variables and see immediate results. These are good fun and a great way to get your learners hands on with physical science!

This is a great way for you to bring technology into your classroom – using a projector or digital whiteboard, access the books on www.everythingscience.co.za and use the videos to provide an additional summary of the concepts you have covered by offering an alternative explanation. After hours, learners that need additional help will know that they can watch the videos in their own time, with the added bonus of being able to stop, pause and rewind the explanation until they have fully grasped the concept. This is great for revision purposes too, as it is like having a personal teacher on hand for every learner, at any time!

See video explanation  (Video : V123)

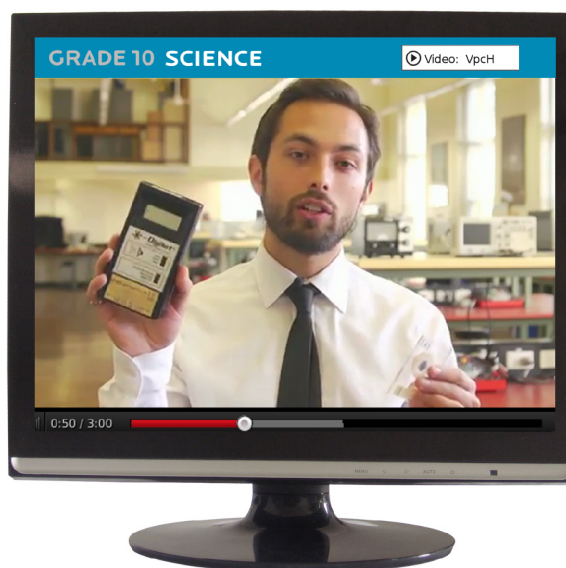
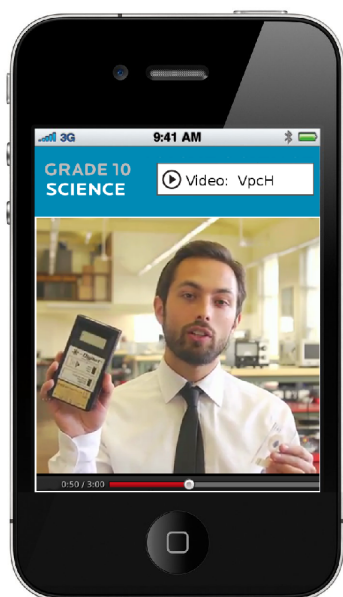

You can access these videos by:

- viewing them on-line on your phone or computer
- downloading the videos for off-line viewing on your phone or computer
- ordering a DVD to play on your TV or computer
- downloading them off-line over Bluetooth or Wi-Fi from select outlets

For additional viewing, downloads or more information, visit the *Everything Science* website on your phone or computer at www.everythingscience.co.za

Video exercises

Wherever there are exercises in the book you will see icons and short-codes for on-line video solutions, practice and help. By entering these short-codes into the box on our website, learners will be taken to video solutions of select exercises to show them step-by-step how to solve such problems. Encourage your learners to access these video exercises, which are great for revision purposes as well as to reinforce your own teaching.

See video exercise  (Video : V123)

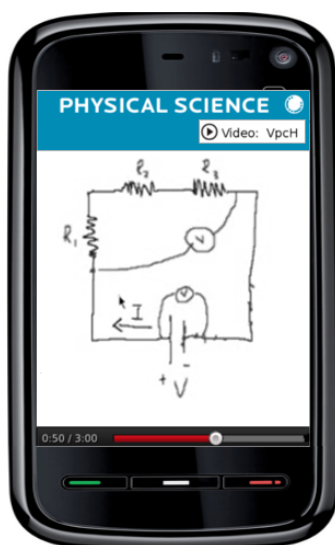

You can access these videos by:

- viewing them on-line on your phone or computer
- downloading the videos for off-line viewing on your phone or computer
- ordering a DVD to play on your TV or computer
- downloading them off-line over Bluetooth or Wi-Fi from select outlets

For additional viewing, downloads or more information, visit the *Everything Science* website on your phone or computer at www.everythingscience.co.za

Intelligent Practice for learners

One of the best ways for learners to prepare for tests and exams is to practice answering the same kind of questions they will be tested on. At every set of exercises in the textbook you will see a practice icon and short-code, which link to an on-line database for learners to practice further exercises. Point your learners at www.everythingscience.co.za on their mobile phone or PC, where they can enter the short-code from the textbook into the box on the website, and be redirected to additional exercises on-line. This on-line practice on **mobile** and **PC** will keep track of learners' performance and progress, give them feedback on areas which require more attention, and suggest which sections or videos to look at.

See more practice **A+** (QM123)

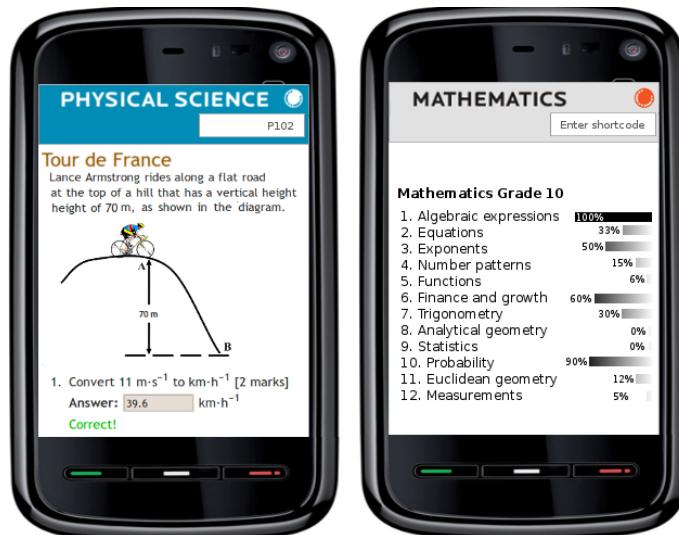

The software can generate any number of questions with the same structure but different details i.e. the numerical values in physics or maths problems can change each time, but the type of question can stay the same. This allows much more variety than a traditional question bank, to the extent that a different practice test can be created automatically for each student in a class. The system also generates a memorandum along with each test, and tracks the learners' conceptual understanding through their success at answering different types of questions.

This tool aims to discover the strong and weak points in learners' understanding as the learners are going through worked examples and drilling exam problems. By knowing with which concepts learners are struggling, the system can then do useful things like

- provide more practice on the types of questions with which the learner is struggling;
- recommend revision material from freely available educational resources (for example, Siyavula's *Everything Maths* and *Everything Science* textbooks);
- provide feedback and reports to learners, educators and parents about their progress and about the specific concepts to which they should pay more attention.

The above is done for each learner individually, delivering a customised practice and revision schedule to match his or her pace and understanding.

Helping learners find answers

When a learner is stuck on a particular section of work in the textbook, they can get additional help by visiting www.everythingscience.co.za on their phone or computer, and find out if other learners also had a question about that same section of the work. If a question has been posted, educators can go on-line and respond, thereby helping other learners that may have been stuck on the same problem.



Database of questions and answers

We invite learners to browse our database of questions and answer for every sections and exercises in the book. They can use the short-code for the section or exercise where they have a question and enter it into the short-code search box on the web or mobi-site at www.everythingmaths.co.za or www.everythingscience.co.za. They will be directed to all the questions previously asked by learners and answered by experts for that section or exercise.



(P78) Visit this section to post or view questions

Ask an expert

They can't find their question or the answer to it in the questions database? Then we invite them to try our service where they can send their question directly to an expert who will reply with an answer. Again, they use the short-code for the section or exercise in the book to identify communicate their problem area.



(QM123) Help or ask a question

Tell us how to improve the book

If you have any comments, thoughts or suggestions on the books, visit www.everythingscience.co.za, and switch to educator mode (you will see on the website how to do this), and using our annotator tool, you can capture these in the text. These can range from sharing tips and ideas on the content in the textbook with your fellow educators, to discussing how to better explain concepts in class. Also, if you have picked up any errors in the book you can make a note of them here, and we will correct them in time for the next print run. The image below illustrates this.

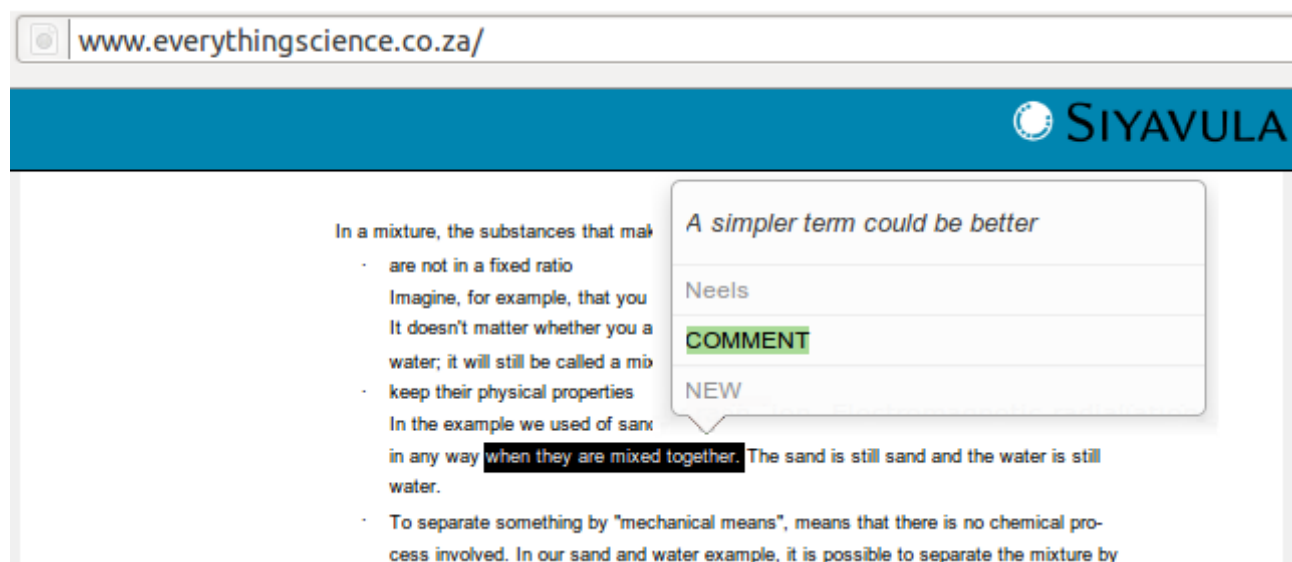

The screenshot shows a web browser window with the address bar containing www.everythingscience.co.za/. The page header features the Siyavula logo. The main content area displays a textbook passage about mixtures. A comment box is overlaid on the text, containing the following text:

A simpler term could be better

Needs

COMMENT

NEW

The background text from the textbook is partially visible:

In a mixture, the substances that make up the mixture

- are not in a fixed ratio

Imagine, for example, that you have a mixture of sand and water. It doesn't matter whether you have a mixture of sand and water; it will still be called a mixture.

- keep their physical properties

In the example we used of sand and water, the sand is still sand in any way **when they are mixed together.** The sand is still sand and the water is still water.

- To separate something by "mechanical means", means that there is no chemical process involved. In our sand and water example, it is possible to separate the mixture by

Setting tests with Monassis

Siyavula offers an open online assessment bank called Monassis, for the sharing and accessing of curriculum-aligned test and exam questions with answers. All the questions and solutions found in the textbook are hosted on-line on Monassis. In addition to this, this site enables educators to quickly set tests and exam papers, by selecting items from the library and adding them to their test. Educators can then download their separate test and memo which is ready for printing. Monassis further offers educators the option of capturing their learners' marks in order to view a selection of diagnostic reports on their performance.



Find & contribute questions.
Make life easier for yourself & thousands of other teachers.

Browse Questions Find Questions Contribute Questions

Find Questions

14 questions matched your search criteria.

Sort on: **newest** popular likes views

Modify the following circuit diagram with two ammeters **A1** and **A2** at different locations in the circuit diagram to measure the current through **R1**. Then add voltmeter **V1** to measure the potential difference in **R2** and voltmeter **V2** to measure the potential difference across **R2** and **R3**.



[View](#) 14 June 2011 · Heather Williams · 0 marks · 0 mins

Like 0 likes, 0 dislikes

We encourage you to make use of Monassis - let it help you save time setting tests and analysing learner marks! Visit Monassis at <http://www.monassis.com>

Table of Contents

Support for educators.....	6
First Layer: Educator Collaboration.....	6
Second Layer: Classroom Engagement.....	7
Third Layer: Beyond the Classroom.....	7
On the Web, Everyone can be a Scientist.....	8
Looking for Little Green Men.....	8
You are a Computer, too.....	9
Blog Posts	11
General Blogs.....	11
Chemistry Blogs	12
Physics Blogs.....	13
Overview.....	14
Curriculum Overview.....	15
Physical Sciences.....	16
The specific aims of Physical Sciences.....	16
Developing language skills: reading and writing.....	17
Time Allocation of the Physical Sciences in the Curriculum.....	18
Topics and Content to be Dealt with in Grade 10.....	18
An Overview of Practical Work.....	19
Formal assessment.....	20
Term 1: Chemistry	20
Term 2: Physics.....	21
Term 3: Physics	22
Informal assessment.....	23
Term 1: Chemistry.....	23
Term 1: Physics.....	23
Term 2: Chemistry.....	23
Term 2: Physics.....	23
Term 3: Chemistry.....	24
Term 3: Physics	24
Term 4: Chemistry.....	24
Term 4: Chemistry.....	24
Physical Sciences Content (Grade 10).....	28
Work Schedule	28
Assessment.....	33
Informal or Daily Assessment.....	33
Formal Assessment.....	34
Control Tests & Examinations.....	34
Practical Investigations & Experiments.....	35
Requirements for Grade 10 Practical Work.....	35
Projects.....	35

Assessment Tools.....	36
Rubrics.....	37
End-of-Year Examinations: Grade 10 (Internal).....	39
Assessment plan and weighting of tasks in the programme of assessment for Grade 10:.....	40
Recording and Reporting.....	41
Skills for physical sciences learners.....	41
Overview of Chapters.....	42
Skills for science	42
Classification of matter.....	42
States of matter and the kinetic molecular theory (KMT).....	43
The atom.....	44
The periodic table.....	44
Chemical bonding.....	44
Transverse pulses.....	45
Transverse waves.....	45
Longitudinal waves.....	45
Sound.....	45
Electromagnetic radiation.....	46
The particles that substances are made of.....	46
Physical and chemical change.....	46
Representing chemical change.....	47
Magnetism.....	47
Electrostatics.....	48
Electric circuits.....	49
Reactions in aqueous solution.....	50
Quantitative aspects of chemical change.....	50
Vectors and scalars.....	51
Motion in one dimension.....	51
Mechanical energy	52
The hydrosphere.....	53
Units used in the book.....	53
Exercise Solutions.....	53
Chapter solutions.....	54
Chapter 1. Skills for science	54
Exercise 1-1:	54
Exercise 1-2:.....	55
Chapter 2. Classification of matter.....	57
Exercise 2-1:	57
Exercise 2-2:	58
Exercise 2-3:	59

End of chapter exercises:.....	60
Chapter 3. States of matter and the kinetic molecular theory.....	64
End of chapter exercises:.....	64
Chapter 4. The atom.....	67
Exercise 4-1:.....	67
Exercise 4-2:.....	67
Exercise 4-3:.....	71
Exercise 4-4:.....	75
Exercise 4-5:.....	75
End of chapter exercises:.....	79
Chapter 5. The periodic table.....	86
Exercise 5-2:	90
End of chapter exercises:.....	93
Chapter 6. Chemical bonding.....	99
Exercise 6-1:.....	99
Exercise 6-2:.....	101
Exercise 6-3:.....	103
Exercise 6-4:.....	105
Exercise 6-5:	107
End of chapter exercises.....	108
Chapter 7. Transverse pulses.....	112
Exercise 7-1:.....	112
Exercise 7-2:.....	113
End of chapter exercises:.....	125
Chapter 8. Transverse waves.....	128
Exercise 8-1:.....	128
End of chapter exercises:.....	136
Chapter 9. Longitudinal waves.....	138
End of chapter exercises:.....	138
Chapter 10. Sound.....	140
Exercise 10-1:.....	140
End of chapter exercises:.....	141
Chapter 11. Electromagnetic radiation	150
Exercise 11-1:.....	150
Exercise 11-2:.....	151
Exercise 11-3:.....	151
End of chapter exercises:.....	152
Chapter 12. The particles that substances are made of.....	156
End of chapter exercises:.....	156
Chapter 13. Physical and chemical change.....	160
Exercise 13-1:.....	160

Exercise 13-2:.....	160
End of chapter exercises:.....	162
Chapter 14. Representing chemical change.....	165
Exercise 14-1:.....	165
Exercise 14-2:.....	166
Exercise 14-3:.....	171
End of chapter exercises:.....	172
Chapter 15. Magnetism.....	178
End of chapter exercises:.....	178
Chapter 16. Electrostatics.....	183
End of Chapter Exercises:.....	183
Chapter 17. Electric circuits	189
Exercise 17-1:.....	189
End of chapter exercises:.....	190
Chapter 18. Reactions in aqueous solution.....	196
Exercise 18-1:.....	196
Exercise 18-2:.....	197
End of chapter exercises:.....	198
Chapter 19. Quantitative aspects of chemical change.....	202
Exercise 19-1:	202
Exercise 19-2:.....	203
Exercise 19-3:.....	205
Exercise 19-4:.....	207
Exercise 19-5:.....	210
Exercise 19-6:.....	214
Exercise 19-7:.....	217
End of chapter exercises:.....	220
Chapter 20. Vectors and scalars.....	232
Exercise 20-1:.....	232
Exercise 20-2:	232
Exercise 20-3:.....	233
Exercise 20-4:.....	234
Exercise 20-5:.....	238
End of chapter exercises:.....	242
Chapter 21. Motion in one dimension	244
Exercise 21-1:.....	244
Exercise 21-2:.....	245
Exercise 21-3:.....	246
Exercise 21-4:.....	249
Exercise 21-5:.....	250
Exercise 21-6:.....	253

Exercise 21-7:.....	257
End of chapter exercises:.....	260
Chapter 22. Mechanical energy.....	274
Exercise 22-1:.....	274
Exercise 22-2:.....	275
Exercise 22-3:.....	277
End of chapter exercises:.....	281
Chapter 23. The hydrosphere.....	286
End of chapter exercises.....	286

Support for educators

Science education is about more than physics, chemistry and mathematics... It's about learning to think and to solve problems, which are valuable skills that can be applied through all spheres of life. Teaching these skills to our next generation is crucial in the current global environment where methodologies, technology and tools are rapidly evolving. Education should benefit from these fast moving developments. In our simplified model there are three layers to how technology can significantly influence your teaching and teaching environment.

First Layer: Educator Collaboration

There are many tools that help educators collaborate more effectively. We know that communities of practice are powerful tools for the refinement of methodology, content and knowledge and are also superb for providing support to educators. One of the challenges facing community formation is the time and space to have sufficient meetings to build real communities and exchange practices, content and learnings effectively. Technology allows us to streamline this very effectively by transcending space and time. It is now possible to collaborate over large distances (transcending space) and when it is most appropriate for each individual (transcending time) by working virtually (email, mobile, online etc.).

Our textbooks have been re-purposed from content available on the Connexions website (<http://cnx.org/lenses/fhsst>). The content on this website is easily accessible and adaptable as it is under an open licence, stored in an open format, based on an open standard, on an open-source platform, for free, where everyone can produce their own books. The content on Connexions is available under an open copyright license - CC-BY. This Creative Commons By Attribution Licence allows others to legally distribute, remix, tweak, and build upon the work available, even commercially, as long as the original author is credited for the original creation. This means that learners and educators are able to download, copy, share and distribute this content legally at no cost. It also gives educators the freedom to edit, adapt, translate and contextualise it, to better suit their teaching needs.

Connexions is a tool where individuals can share, but more importantly communities can form around the collaborative, online development of resources. Your community of educators can therefore:

- form an online workgroup around the content;
- make your own copy of the content;
- edit sections of your own copy;
- add your own content or replace existing content with your own content;
- use other content that has been shared on the platform in your own work;
- create your own notes / textbook / course material as a community.

Educators often want to share assessment items as this helps reduce workload, increase variety and improve quality. Currently all the solutions to the exercises contained in the textbooks have been uploaded onto our free and open online assessment bank called Monassis (www.monassis.com), with each exercise having a shortcode link to its solution on Monassis. To access the solution simply go to www.everythingscience.co.za , enter the shortcode, and you will be redirected to the solution on Monassis.

Monassis is similar to Connexions but is focused on the sharing of assessment items. Monassis contains a selection of test and exam questions with solutions, openly shared by educators. Educators can further search and browse the database by subject and grade and add relevant items to a test. The website automatically generates a test or exam paper with the corresponding memorandum for download.

By uploading all the end-of-chapter exercises and solutions to this open assessment bank, the larger community of educators in South Africa are provided with a wide selection of items to use in setting their tests and exams. More details about the use of Monassis as a collaboration tool are included in the Monassis section.

Second Layer: Classroom Engagement

In spite of the impressive array of rich media open educational resources available freely online (such as videos, simulations, exercises and presentations), only a small number of educators actively make use of them. Our investigations revealed that the overwhelming quantity, the predominant international context, and difficulty in correctly aligning them with the local curriculum level acts as deterrents. The opportunity here is that, if used correctly, they can make the classroom environment more engaging.

Presentations can be a first step to bringing material to life in ways that are more compelling than are possible with just a blackboard and chalk. There are opportunities to:

- create more graphical representations of the content;
- control timing of presented content more effectively;
- allow learners to relive the lesson later if constructed well;
- supplement the slides with notes for later use;
- embed key assessment items in advance to promote discussion; and
- embed other rich media like videos.

Videos have been shown to be potentially both engaging and effective. They provide opportunities to:

- present an alternative explanation;
- challenge misconceptions without challenging an individual in the class; and
- show an environment or experiment that cannot be replicated in the class which could be far away, too expensive or too dangerous.

Simulations are also very useful and can allow learners to:

- have increased freedom to explore, rather than reproduce a fixed experiment or process;
- explore expensive or dangerous environments more effectively; and
- overcome implicit misconceptions.

We realised the opportunity for embedding a selection of rich media resources such as presentations, simulations, videos and links into the online version of *Everything Maths and Everything Science* at the relevant sections. This will not only present them with a selection of locally relevant and curriculum aligned resources, but also position these resources within the appropriate grade and section. Links to these online resources are recorded in the print or PDF versions of the books, making them a tour-guide or credible pointer to the world of online rich media available.

Third Layer: Beyond the Classroom

The internet has provided many opportunities for self-learning and participation which were never before possible. There are huge stand-alone archives of videos like the Khan Academy which covers most Mathematics for Grades 1 - 12 and Science topics required in FET. These videos, if not used in class, provide opportunities for the learners to:

- look up content themselves;
- get ahead of class;
- independently revise and consolidate their foundation; and
- explore a subject to see if they find it interesting.

There are also many opportunities for learners to participate in science projects online as real participants (see the section on citizen cyberscience “On the web, everyone can be a scientist”). Not just simulations or tutorials but real science so that:

- learners gain an appreciation of how science is changing;
- safely and easily explore subjects that they would never have encountered before university;
- contribute to real science (real international cutting edge science programmes);
- have the possibility of making real discoveries even from their school computer laboratory; and
- find active role models in the world of science.

In our book we’ve embedded opportunities to help educators and learners take advantage of all these resources, without becoming overwhelmed at all the content that is available online.

On the Web, Everyone can be a Scientist

Did you know that you can fold protein molecules, hunt for new planets around distant suns or simulate how malaria spreads in Africa, all from an ordinary PC or laptop connected to the Internet? And you don’t need to be a certified scientist to do this. In fact some of the most talented contributors are teenagers. The reason this is possible is that scientists are learning how to turn simple scientific tasks into competitive online games.

This is the story of how a simple idea of sharing scientific challenges on the Web turned into a global trend, called citizen cyberscience. And how you can be a scientist on the Web, too.

Looking for Little Green Men

A long time ago, in 1999, when the World Wide Web was barely ten years old and no one had heard of Google, Facebook or Twitter, a researcher at the University of California at Berkeley, David Anderson, launched an online project called SETI@home. SETI stands for Search for Extraterrestrial Intelligence. Looking for life in outer space.

Although this sounds like science fiction, it is a real and quite reasonable scientific project. The idea is simple enough. If there are aliens out there on other planets, and they are as smart or even smarter than us, then they almost certainly have invented the radio already. So if we listen very carefully for radio signals from outer space, we may pick up the faint signals of intelligent life.

Exactly what radio broadcasts aliens would produce is a matter of some debate. But the idea is that if they do, it would sound quite different from the normal hiss of background radio noise produced by stars and galaxies. So if you search long enough and hard enough, maybe you’ll find a sign of life.

It was clear to David and his colleagues that the search was going to require a lot of computers. More than scientists could afford. So he wrote a simple computer program which broke the problem down into smaller parts, sending bits of radio data collected by a giant radio-telescope to volunteers around the world. The volunteers agreed to download a programme onto their home computers that would sift through the bit of data they received, looking for signals of life, and send back a short summary of the result to a central server in California.

The biggest surprise of this project was not that they discovered a message from outer space. In fact, after over a decade of searching, no sign of extraterrestrial life has been found, although there are still vast regions of space that have not been looked at. The biggest surprise was the number of people willing to help such an endeavour. Over a million people have downloaded the software, making the total computing power

of SETI@home rival that of even the biggest supercomputers in the world.

David was deeply impressed by the enthusiasm of people to help this project. And he realized that searching for aliens was probably not the only task that people would be willing to help with by using the spare time on their computers. So he set about building a software platform that would allow many other scientists to set up similar projects. You can read more about this platform, called BOINC, and the many different kinds of volunteer computing projects it supports today, at <http://boinc.berkeley.edu/> .

There's something for everyone, from searching for new prime numbers (PrimeGrid) to simulating the future of the Earth's climate (ClimatePrediction.net). One of the projects, MalariaControl.net, involved researchers from the University of Cape Town as well as from universities in Mali and Senegal.

The other neat feature of BOINC is that it lets people who share a common interest in a scientific topic share their passion, and learn from each other. BOINC even supports teams – groups of people who put their computer power together, in a virtual way on the Web, to get a higher score than their rivals. So BOINC is a bit like Facebook and World of Warcraft combined – part social network, part online multiplayer game.

Here's a thought: spend some time searching around BOINC for a project you'd like to participate in, or tell your class about.

You are a Computer, too

Before computers were machines, they were people. Vast rooms full of hundreds of government employees used to calculate the sort of mathematical tables that a laptop can produce nowadays in a fraction of a second. They used to do those calculations laboriously, by hand. And because it was easy to make mistakes, a lot of the effort was involved in double-checking the work done by others.

Well, that was a long time ago. Since electronic computers emerged over 50 years ago, there has been no need to assemble large groups of humans to do boring, repetitive mathematical tasks. Silicon chips can solve those problems today far faster and more accurately. But there are still some mathematical problems where the human brain excels.

Volunteer computing is a good name for what BOINC does: it enables volunteers to contribute computing power of their PCs and laptops. But in recent years, a new trend has emerged in citizen cyberscience that is best described as volunteer thinking. Here the computers are replaced by brains, connected via the Web through an interface called eyes. Because for some complex problems – especially those that involve recognizing complex patterns or three-dimensional objects – the human brain is still a lot quicker and more accurate than a computer.

Volunteer thinking projects come in many shapes and sizes. For example, you can help to classify millions of images of distant galaxies (GalaxyZoo), or digitize hand-written information associated with museum archive data of various plant species (Herbaria@home). This is laborious work, which if left to experts would take years or decades to complete. But thanks to the Web, it's possible to distribute images so that hundreds of thousands of people can contribute to the search.

Not only is there strength in numbers, there is accuracy, too. Because by using a technique called validation – which does the same sort of double-checking that used to be done by humans making mathematical tables – it is possible to practically eliminate the effects of human error. This is true even though each volunteer may make quite a few mistakes. So projects like Planet Hunters have already helped astronomers pinpoint new planets circling distant stars. The game FoldIt invites people to compete in folding protein molecules via

a simple mouse-driven interface. By finding the most likely way a protein will fold, volunteers can help understand illnesses like Alzheimer's disease, that depend on how proteins fold.

Volunteer thinking is exciting. But perhaps even more ambitious is the emerging idea of volunteer sensing: using your laptop or even your mobile phone to collect data – sounds, images, text you type in – from any point on the planet, helping scientists to create global networks of sensors that can pick up the first signs of an outbreak of a new disease (EpiCollect), or the initial tremors associated with an earthquake (QuakeCatcher.net), or the noise levels around a new airport (NoiseTube).

There are about a billion PCs and laptops on the planet, but already 5 billion mobile phones. The rapid advance of computing technology, where the power of a ten-year old PC can easily be packed into a smart phone today, means that citizen cyberscience has a bright future in mobile phones. And this means that more and more of the world's population can be part of citizen cyberscience projects. Today there are probably a few million participants in a few hundred citizen cyberscience initiatives. But there will soon be seven billion brains on the planet. That is a lot of potential citizen cyberscientists.

You can explore much more about citizen cyberscience on the Web. There's a great list of all sorts of projects, with brief summaries of their objectives, at <http://distributedcomputing.info/>. BBC Radio 4 produced a short series on citizen science <http://www.bbc.co.uk/radio4/science/citizenscience.shtml> and you can subscribe to a newsletter about the latest trends in this field at <http://scienceforcitizens.net/>. The Citizen Cyberscience Centre, www.citizencyberscience.net which is sponsored by the South African Shuttleworth Foundation, is promoting citizen cyberscience in Africa and other developing regions.

Blog Posts

General Blogs

- **Educator's Monthly** - Education News and Resources
 - "We eat, breathe and live education! "
 - "Perhaps the most remarkable yet overlooked aspect of the South African teaching community is its enthusiastic, passionate spirit. Every day, thousands of talented, hard-working educators gain new insight from their work and come up with brilliant, inventive and exciting ideas. Educator's Monthly aims to bring educators closer and help them share knowledge and resources.
 - Our aim is twofold ...
 - To keep South African educators updated and informed.
 - To give educators the opportunity to express their views and cultivate their interests."
- <http://www.teachersmonthly.com>

- **Head Thoughts** – Personal Reflections of a School Headmaster
 - blog by Arthur Preston
 - "Arthur is currently the headmaster of a growing independent school in Worcester, in the Western Cape province of South Africa. His approach to primary education is progressive and is leading the school through an era of new development and change."
- <http://headthoughts.co.za/>

- **Reflections of a Science Teacher** - Scientist, Educator, Life-Long Learner
 - blog by Sandra McCarron
 - "After 18 years as an Environmental Consultant, I began teaching high school science and love it. My writings here reflect some of my thoughts about teaching, as they occur. I look forward to conversations with other thoughtful teachers."
- <http://sanmccarron.blogspot.com/>

- **René Toerien** – Resources for science teachers
 - blog by René Toerien
 - "I am the coordinator of the UCT Chemical Engineering Schools Project. We develop resource materials for the South African Physical Sciences curriculum."
- <http://renetoerien.net/>

- **The Naked Scientists** - Science Radio and Naked Science Podcasts
 - "The Naked Scientists" are a media-savvy group of physicians and researchers from Cambridge University who use radio, live lectures, and the Internet to strip science down to its bare essentials, and promote it to the general public. Their award winning BBC weekly radio programme, The Naked Scientists, reaches a potential audience of 6 million listeners across the east of England, and also has an international following on the web."

- <http://www.thenakedscientists.com/>

Chemistry Blogs

- **Chemical Heritage Foundation – We Tell the Story of Chemistry**
 - “The Chemical Heritage Foundation (CHF) fosters an understanding of chemistry’s impact on society. An independent, nonprofit organization, CHF maintains major collections of instruments, fine art, photographs, papers, and books. We host conferences and lectures, support research, offer fellowships, and produce educational materials. Our museum and public programs explore subjects ranging from alchemy to nanotechnology.”
- <http://www.chemheritage.org/>
- **ChemBark – A Blog About Chemistry and Chemical Research**
 - blog maintained by Paul Bracher
 - “The scope of this blog is the world of chemistry and chemical research. Common subjects of discussion include ideas, experiments, data, publications, writing, education, current events, lab safety, scientific policy, academic politics, history, and trivia.”
- <http://blog.chembark.com/>
- **Chemistry World Blog**
 - “This blog provides a forum for news, opinions and discussion about the chemical sciences. Chemistry World is the monthly magazine of the UK’s Royal Society of Chemistry.”
- <http://www.rscweb.org/blogs/cw/>
- **Chemistry Blog**
 - “A brand new site for chemists and the home of the international chemistry societies’ electronic network. The site provides interesting features and useful services for the chemistry community. The information you find has been made available by various national chemistry societies for dissemination on a single site. Currently around 30 such societies are providing varying levels of information.”
- <http://www.chemistryblog.net/>
- **Master Organic Chemistry**
 - blog by James A. Ashenurst
 - “I’m James. I’ve been an organic chemist for ten years. I love organic chemistry and I want to put the image of organic chemistry as a horror movie to rest (or at least make it less scary and more campy). The main goal for this site is that it be a place for conversation between students and educators. I also hope that it will be useful and valuable for students of organic chemistry.”
- <http://masterorganicchemistry.com/>
- **About.com Chemistry**
 - This website is full of great chemistry information, including Chem 101, science projects, elements, plus many interesting articles, including a daily “This Day in Science History”

- <http://chemistry.about.com/>

Physics Blogs

- **dotphysics**
 - blog by Rhett Allain
 - “This blog is about physics. Not crazy hard physics, but nice physics. You know, like physics you would take home to your mom. I try to aim most of the posts at the physics level an advanced high school student could understand.”
- <http://scienceblogs.com/dotphysics/>

- **Think Thank Thunk – Dealing with the Fear of Being a Boring Teacher**
 - blog by Shawn Cornally
 - “I am Mr. Cornally. I desperately want to be a good teacher. I teach Physics, Calculus, Programming, Geology, and Bioethics. Warning: I have problem with using colons. I proof read, albeit poorly.”
- <http://101studiotstreet.com/wordpress/>

Overview

Dear educator, welcome to the force of educators that make a difference by unlocking the marvels of the Physical Sciences to learners. What a privilege you have to guide the learners in becoming critical thinkers!

To improve curriculum implementation and to meet the vision for our nation, the National Curriculum Statement Grades R - 12 (NCS) was revised, changed and is replaced by a national policy document developed for each subject. All Physical Sciences educators in the country have to use the National Curriculum and Assessment Policy Statement for Physical Sciences. This policy document replaces all old Subject Statements, Learning Programme Guidelines and Subject Assessment Guidelines in Grades R - 12. These changed curriculum and assessment requirements come into effect in January 2012. As a Physical Sciences educator for Grade 10, you need to have a sound understanding of the National Curriculum and Assessment Policy Statement for Physical Sciences.

This teachers' guide is divided into two main parts:

- **Part 1** deals with the policy document; and
- **Part 2** with the learners' textbook.

Part 1

The National Curriculum and Assessment Policy Statement for Physical Sciences has four sections:

Section 1: Curriculum overview

Section 2: Physical Sciences

Section 3: Physical Sciences Content (Grades 10 - 12)

Section 4: Assessment

This part will assist you in getting to grips with the objectives and requirements laid down for the Physical Sciences at national level, and how to implement the prescribed policy document.

Part 2

Each chapter in the textbook addresses prescribed content, concepts and skills. The range of activities includes practical activities, experiments, and informal and formal assessment tasks.

Curriculum Overview

From the beginning of January 2012, all learning and teaching in public and independent schools in South Africa is laid down in the National Curriculum and Assessment Policy Statements (January 2012) (CAPS) document. National Curriculum and Assessment Policy Statements were developed for each subject and replace all previous policy statements including:

1. National Senior Certificate: a qualification at Level 4 on the National Qualifications Framework (NQF);
2. An addendum to the policy document, the National Senior Certificate: a qualification at Level 4 on the National Qualifications Framework (NQF), regarding learners with special needs, published in the Government Gazette, No. 29466 of 11 December 2006;
3. The Subject Statements, Learning Programme Guidelines and Subject Assessment Guidelines for Grades R - 9 and Grades 10 - 12.

The following sections in this document set out the expected norms and standards and minimum outcomes, as well as processes and procedures for the assessment of learner achievement in public and independent schools.

The national agenda and how the curriculum can serve this agenda:

- (a) The knowledge, skills and values worth learning for learners in South Africa are clearly set out in the National Curriculum and Assessment Policy Statement for Physical Sciences. The content links to the environment of the learners and is presented within local context, with awareness of global trends.
- (b) The National Curriculum Statement Grades R - 12 undertakes to:
 - equip all learners, irrespective of their socio-economic background, race, gender, physical ability or intellectual ability, with the knowledge, skills and values necessary for self-fulfilment to participate meaningfully in society as citizens of a free country;
 - provide access to higher education;
 - facilitate the transition of learners from education institutions to the workplace; and
 - provide employers with a sufficient profile of a learner's competencies.
- (c) The key principles (fuller described in the document) of the National Curriculum Statement for Grades R - 12 are:
 - social transformation: making sure that the educational differences of the past are put right, by providing equal educational opportunities to all;
 - active and critical learning: encouraging an active and critical approach to learning, not only rote learning of given facts;
 - high knowledge and high skills: specified minimum standards of knowledge and skills are set to be achieved at each grade;
 - progression: content and context of each grade shows progression from simple to complex;
 - human rights, inclusivity, environmental and social justice: being sensitive to issues such as poverty, inequality, race, gender, language, age, disability and other factors;
 - valuing indigenous knowledge systems: acknowledging the rich history and heritage of this country; and
 - credibility, quality and efficiency: providing an education that is comparable in quality, breadth and depth to those of other countries.

(d) The aims as listed in the National Curriculum Statement Grades R - 12 interpret the kind of citizen the education systems tries to develop. It aims to produce learners that are able to:

- identify and solve problems and make decisions using critical and creative thinking;
- work effectively as individuals and with others as members of a team;
- organise and manage themselves and their activities responsibly and effectively;
- collect, analyse, organise and critically evaluate information;
- communicate effectively using visual, symbolic and/or language skills in various modes;
- use science and technology effectively and critically showing responsibility towards the environment and the health of others; and
- demonstrate an understanding of the world as a set of related systems by recognising that problem solving contexts do not exist in isolation.

(e) Inclusivity is one of the key principles of the National Curriculum Statement Grades R - 12 and should become a central part of the organisation, planning and teaching at each school.

Educators need to:

- have a sound understanding of how to recognise and address barriers to learning;
- know how to plan for diversity;
- address barriers in the classroom;
- use various curriculum differentiation strategies¹;
- address barriers to learning using the support structures within the community; District-Based Support Teams, Institutional-Level Support Teams, parents and Special Schools as Resource Centres.

Physical Sciences

As economic growth is stimulated by innovation and research which is embedded in the Physical Sciences, this subject plays an increasingly important role to meet the country's needs. The nature of the Physical Sciences and the needs of the country are reflected in the curriculum. The specific aims direct the classroom activities that intend to develop higher order cognitive skills of learners, needed for higher education.

The nature of the Physical Sciences is to:

- investigate physical and chemical phenomena through scientific inquiry, application of scientific models, theories and laws in order to explain and predict events in the physical environment;
- deal with society's need to understand how the physical environment works in order to benefit from it and responsibly care for it;
- use all scientific and technological knowledge, including Indigenous Knowledge Systems (IKS) to address challenges facing society.

The specific aims of Physical Sciences

The specific aims provide guidelines on how to prepare learners to meet the challenges of society and the future during teaching, learning and assessment. The Specific Aims of the Physical Sciences (CAPS document, stated below) are aligned to the three Learning Outcomes (NCS document) with which you are familiar. Developing language skills as such is not a specific aim for the Physical Sciences, but we know that cognitive skills are rooted in language; therefore language support is crucial for success in this subject.

¹ Consult the Department of Basic Education's Guidelines for Inclusive Teaching and Learning (2010)

The specific aims for the Physical Sciences are:

- to promote knowledge and skills in scientific inquiry and problem solving; the construction and application of scientific and technological knowledge; an understanding of the nature of science and its relationships to technology, society and the environment.
- to equip learners with investigating skills relating to physical and chemical phenomena. These skills are: classifying, communicating, measuring, designing an investigation, drawing and evaluating conclusions, formulating models, hypothesising, identifying and controlling variables, inferring, observing and comparing, interpreting, predicting, problem solving and reflective skills.
- to prepare learners for future learning (including academic courses in Higher Education), specialist learning, employment, citizenship, holistic development, socio-economic development, and environmental management. Learners choosing Physical Sciences as a subject in Grades 10 - 12, including those with barriers to learning, can have improved access to professional career paths related to applied science courses and vocational career paths.

Within each of these aims, specific skills or competences have been identified. It is not advisable to try to assess each of the skills separately, nor is it possible to report on individual skills separately. However, well designed assessments must show evidence that, by the end of the year, all of the skills have been assessed at a grade-appropriate level. Study the next section that deals with assessment.

Developing language skills: reading and writing

As a Physical Sciences educator you need to engage in the teaching of language. This is particularly important for learners for whom the Language of Learning and Teaching (LoLT) is not their home language. It is important to provide learners with opportunities to develop and improve their language skills in the context of learning Physical Sciences. It will therefore be critical to afford learners opportunities to read scientific texts, to write reports, paragraphs and short essays as part of the assessment, especially (but not only) in the informal assessments for learning.

Six main knowledge areas inform the Physical Sciences. These are:

- Matter and Materials
- Chemical Systems
- Chemical Change
- Mechanics
- Waves, Sound and Light
- Electricity and Magnetism

Time Allocation of the Physical Sciences in the Curriculum

The teaching time for Physical Sciences is 4 hours per week, with 40 weeks in total per grade. The time allocated for the teaching of content, concepts and skills includes the practical work. These are an integral part of the teaching and learning process.

Grade	No. of Weeks Allocated	Content, Concepts & Skills (Weeks)	Formal Assessment
10	40	30	10
11	40	30	10
12	40	28	12

Topics and Content to be Dealt with in Grade 10

(Consult the National Curriculum and Assessment Policy Statement for Physical Sciences for an overview of Grades 10 - 12)

Topic	Content
Mechanics	<p>Introduction to vectors & scalars; Motion in one dimension (reference frame, position, displacement and distance, average speed, average velocity, acceleration, instantaneous velocity, instantaneous speed, description of motion in words, diagrams, graphs and equations).</p> <p>Energy (gravitational potential energy, kinetic energy, mechanical energy, conservation of mechanical energy (in the absence of dissipative forces).</p> <ul style="list-style-type: none"> • 30 hours
Waves, Sound & Light	<p>Transverse pulses on a string or spring (pulse, amplitude superposition of pulses); Transverse waves (wavelength, frequency, amplitude, period, wave speed, Longitudinal waves (on a spring, wavelength, frequency, amplitude, period, wave speed, sound waves); Sound (pitch, loudness, quality (tone),ultrasound); Electromagnetic radiation (dual (particle/wave); nature of electromagnetic (EM) radiation, nature of EM radiation, EM spectrum, nature of EM as particle – energy of a photon related to frequency and wavelength).</p> <ul style="list-style-type: none"> • 16 hours
Electricity & Magnetism	<p>Magnetism (magnetic field of permanent magnets, poles of permanent magnets, attraction and repulsion, magnetic field lines, earth's magnetic field, compass); Electrostatics (two kinds of charge, force exerted by charges on each other (descriptive), attraction between charged and uncharged objects (polarisation), charge conservation, charge quantization); Electric circuits (emf, potential difference (pd), current, measurement of voltage (pd) and current, resistance, resistors in parallel).</p> <ul style="list-style-type: none"> • 14 hours

Matter & Materials	<p>Revise matter and classification (materials; heterogeneous and homogeneous mixtures; pure substances; names and formulas; metals and non-metals; electrical and thermal conductors and insulators; magnetic and non magnetic materials). States of matter and the kinetic molecular theory. Atomic structure (models of the atom; atomic mass and diameter; protons, neutrons and electrons; isotopes; energy quantization and electron configuration); Periodic table (position of the elements; similarities in chemical properties in groups, electron configuration in groups); Chemical bonding (covalent bonding; ionic bonding; metallic bonding); Particles substances are made of (atoms and compounds; molecular substances and ionic substances).</p> <ul style="list-style-type: none"> • 28 hours
Chemical Systems	<p>Hydrosphere</p> <ul style="list-style-type: none"> • 8 hours
Chemical Change	<p>Physical and chemical change (separation by physical means; separation by chemical means; conservation of atoms and mass; law of constant composition; conservation of energy); Representing chemical change (balanced chemical equations). Reactions in aqueous solution (ions in aqueous solutions; ion interaction; electrolytes; conductivity; precipitation; chemical reaction types); Stoichiometry (mole concept).</p> <ul style="list-style-type: none"> • 28 hours

An Overview of Practical Work

Educators now have clarity regarding the role and assessment of practical work. This document specifies that practical work must be integrated with theory to strengthen the concepts being taught. Practical work can be: simple practical demonstrations; an experiment or practical investigation. In Section 3 practical activities are outlined alongside the content, concepts and skills column. The table below lists prescribed practical activities for formal assessment as well as recommended practical activities for informal assessment in Grade 10.

Term	Prescribed Practical Activities for Formal Assessment	Recommended Practical Activities for Informal Assessment
Term 1	<p>Experiment 1 (Chemistry): Heating and cooling curve of water.</p>	<p>Practical Demonstration (Physics): Use a ripple tank to demonstrate constructive and destructive interference of two pulses or Experiment (Chemistry): Flame tests to identify some metal cations and metals.</p>
Term 2	<p>Experiment 2 (Physics): Electric circuits with resistors in series and parallel – measuring potential difference and current.</p>	<p>Investigation (Physics): Pattern and direction of the magnetic field around a bar magnet or Experiment (Chemistry): Prove the conservation of matter experimentally.</p>

Term 3	<p>Project: Chemistry: Purification and quality of water. or Physics: Acceleration. Roll a ball down an inclined plane and using measurements of time and position obtain a velocity+time graph and hence determine the acceleration of the ball. The following variations could be added to the investigation: i. Vary the angle of inclination and determine how the inclination impacts on the acceleration ii. Keep the angle fixed and use inclined planes made of different materials to determine how the different surfaces impact on the acceleration. One could also compare smooth and rough surface etc.</p>	<p>Experiment (Physics): Roll a trolley down an inclined plane with a ticker tape attached to it, and use the data to plot a position vs. time graph or Experiment (Chemistry): Reaction types: precipitation, gas forming, acid-base and redox reactions.</p>
Term 4		<p>Experiment (Chemistry): Test water samples for carbonates, chlorides, nitrates, nitrites, pH, and look at water samples under the microscope.</p>

The following formal and informal assessments are written according to the order in which they should be taught, as they appear in the CAPS document under Physical Sciences Content.

Formal assessment

Term 1: Chemistry

Chapter: 2 – States of matter and the kinetic molecular theory

Title: Heating and cooling curve of water

This experiment investigates the heating and cooling curves for water. Learners will measure the temperature of ice melting every minute until at least three minutes after the ice has melted. Learners will then boil water and measure the temperature of the water cooling down from boiling.

Learners will need to record their results in a table and then present these results on a graph. The graph must have labels on all the axes, and show temperature on the x-axis and time on the y-axis. Sample graphs are shown below (the heating curve is on the left and the cooling curve on the right):

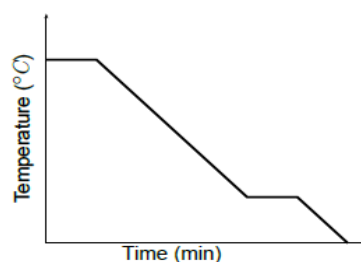
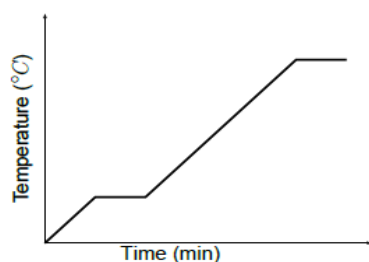

The two flat parts of the curve are really important. This shows that the temperature remained constant for some time while the water was boiling or the ice was melting. This is due to all the energy going into breaking the intermolecular forces between the water molecules.

This experiment involves working with Bunsen burners and boiling water. When working with Bunsen burners all flammable substance are to be kept away from the Bunsen burner. Learners must not leave Bunsen burners unattended. Learners must tie long hair up and keep scarves and loose clothing tucked away. When working with Bunsen burners always open all the windows and keep the room well ventilated.

When the water has boiled learners should turn off the Bunsen burner. Learners should then place a thermometer into the beaker without removing the beaker from above the Bunsen burner. Only when the water is cold, should the beaker be moved.

Term 2: Physics

Chapter: 16 – Electric circuits

Title: Voltage dividers Title: Current dividers

NOTE: CAPS only mentions one experiment, we have split this in half in the book.

Voltage dividers:

This experiment investigates what happens when resistors are connected in series in an electric circuit.

Learners will construct three circuits in this experiment:

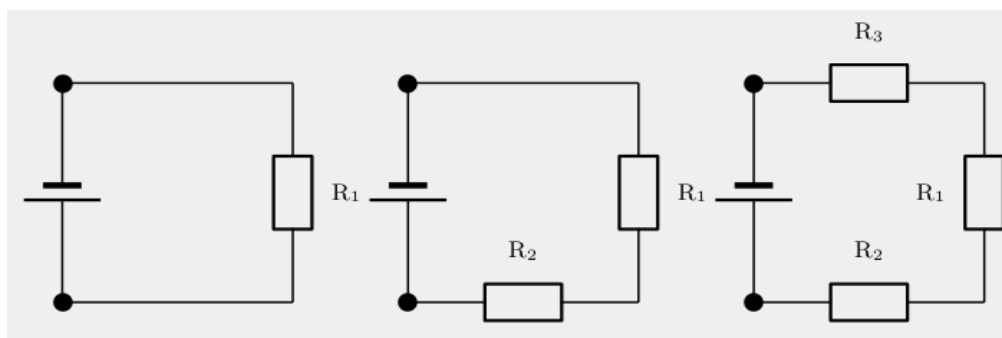

In each of these circuits the learners will measure the voltage and current. The voltage is measured across each resistor. The current is measured before and after each resistor.

Learners should find that the current is the same everywhere in the circuit, but the voltage is not. Learners should find the potential difference across the battery is equal to the sum of the potential differences across each resistor.

Current dividers:

This experiment investigates what happens when resistors are connected in parallel in an electric circuit.

Learners will construct three circuits in this experiment:

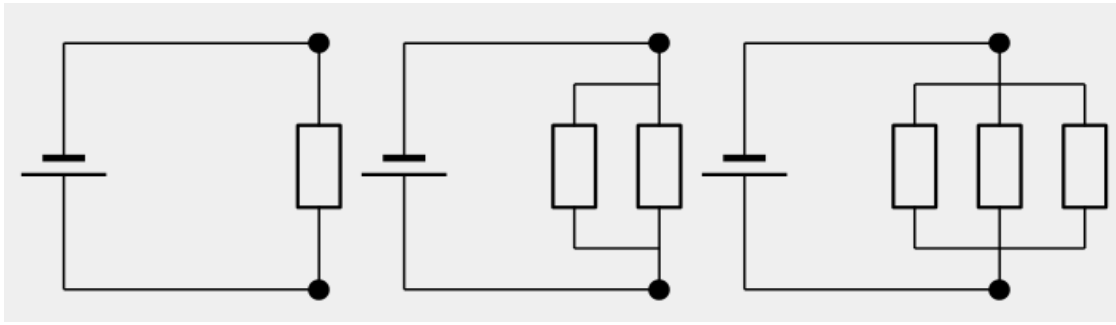

In each of these circuits the learners will measure the voltage and current. The voltage is measured across each resistor. The current is measured before and after each resistor, as well as before and after each parallel branch.

Learners should find that the voltage is the same everywhere in the circuit, but the current is not.

Term 3: Physics

Chapter: 20 – Motion in one dimension

Title: Position versus time using a ticker timer.

In this experiment learners will use a ticker timer and ticker tape to determine the position versus time graph for a trolley rolling down a ramp. By using the distance between successive dots and the frequency of the ticker timer they will be able to draw a graph of position versus time. This experiment could be combined with the formal experiment on acceleration.

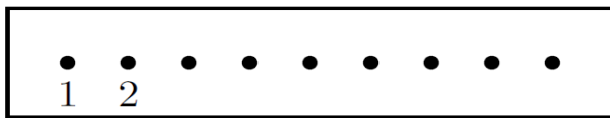

A sample ticker tape is shown above. Learners will begin by measuring the distance between dot 1 and dot 2 and making a note of this distance. Learners will then repeat this for dot 2 and the next dot, and so on. This ticker tape shows motion at constant velocity.

Motion with increasing velocity is shown below:

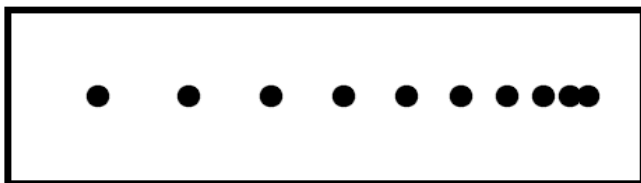

As a challenge to learners you could present them with the following ticker tape and ask them what this represents:



This ticker tape represents motion with constant position.

Informal assessment

Term 1: Chemistry

Chapter: 3 – The atom

Title: Flame tests

NOTE: Although CAPS states to use bamboo sticks, we have opted to use toothpicks since these are more easily available.

In this experiment learners will investigate the different colour flames produced by metals and metal salts. It is important that learners do not hold the toothpick with the metal/metal salt on it in the flame as this will cause the toothpick to burn and give the incorrect colour. The colours of some of the salts are difficult to see against the flame. As this experiment uses a Bunsen burner, all flammable substances must be kept away from the Bunsen burner and the same guidelines apply as expressed in the above experiment for the heating and cooling curve of water.

Term 1: Physics

Chapter: 6 – Transverse pulse

Title: Constructive and destructive interference

In this experiment learners will use a ripple tank to investigate constructive and destructive interference. Learners will begin by producing a single pulse and observing what happens. To see constructive interference, two pulses are produced simultaneously. To see destructive interference, two pulses are produced at slightly different times.

Term 2: Chemistry

Chapter: 12 – Physical and chemical change

Title: Conservation of matter

In this experiment learners will investigate the conservation of matter. They will perform 3 separate experiments that look at various aspects of the conservation of matter. The first experiment involves mixing lead(II) nitrate and sodium iodide solution. The second experiment is an acid-base reaction using hydrochloric acid and sodium hydroxide. The third experiment involves dissolving a fizzy tablet in water.

In each experiment the mass before reaction and the total mass after reaction is determined.

Learners must work carefully with acids and bases as these can cause severe chemical burns. If learners spill acid/base on themselves they must immediately rinse the area under running water for at least 5 minutes. If they have split a large amount on themselves, they should remove the item of clothing that the acid spilled on and stand under running water (you can take the learner to the bathroom to do this).

Learners must be careful handling the silver nitrate as it stains the skin. It is recommended that learners work with gloves for this.

Acids and bases can be washed down the sink with plenty of running water.

Term 2: Physics

Chapter: 14 – Magnetism

Title: Field around a bar magnet; Title: Field around a pair of bar magnets

In these investigations learners will use iron filings to 'see' the magnetic field around bar magnets.

Term 3: Chemistry

Chapter: 17 – Reactions in aqueous solution

Title: Reaction types

This experiment illustrates the different types of reactions. For this experiment various salts and pairs of salts are dissolved in water. If a precipitate forms, then one can say that a precipitation reaction has occurred. A gas forming reaction is also done using sodium carbonate in hydrochloric acid. This is seen by bubbles of gas forming in the solution. The acid-base reaction between sodium hydroxide and hydrochloric acid is performed. Learners will not do a full on titration, but rather a qualitative investigation to see the colour change of the indicator. For the oxidation reaction zinc metal is placed in copper(II) sulphate solution. The copper sulphate solution turns colourless and the zinc metal dissolves in the solution.

Once again, learners must be careful handling the acid and base.

Term 3: Physics

Chapter: 20 – Motion in one dimension

Title: Position versus time using a ticker timer.

In this experiment learners will use a ticker timer and ticker tape to determine the position versus time graph for a trolley rolling down a ramp. By using the distance between successive dots and the frequency of the ticker timer they will be able to draw a graph of position versus time. This experiment could be combined with the formal experiment on acceleration.

Term 4: Chemistry

Chapter: 22 – The hydrosphere

Title: Water purity

This experiment looks at the substances in water and what is in water. Learners will look at water samples from various sources. Each sample will be examined under a microscope and then various tests carried out. Testing for pH and anions in solutions is done. The tests for anions are all covered in the chapter on reactions in aqueous solution.

Term 4: Chemistry

Chapter: 22 – The hydrosphere

Title: Project: Water purification

Learners will prepare a poster or presentation on the purity of water. The following topics are suggested along with some guidelines as to the amount of content they should cover:

- Water for drinking (potable water) - 20%
- Distilled water and its uses – 5%
- Deionised water and its uses – 5%

- What methods are used to prepare water for various uses - 15%
- What regulations govern drinking water - 20%
- Why water needs to be purified - 20%
- How safe are the purification methods – 15%

The assessment rubric below could be used for the above project (poster), as adapted from the UCT Chemical Engineering Mining and Mineral Processing Resource Pack.

Project - Poster							
Research (individual) (30 marks)	Not achieved 0–29%		Moderate 30–49%	Adequate/ Substantial 50–69%		Outstanding 70–100%	
• Use of available resources	0	1	2	3	4	5	6
• Accuracy of interpretation of information	0	1	2	3	4	5	6
• Coverage of the topic	0	1	2	3	4	5	6
• Quality of writing	0	1	2	3	4	5	6
Research (group) (25 marks)	Not achieved 0–29%		Moderate 30–49%	Adequate/ Substantial 50–69%		Outstanding 70–100%	
• The research question was thoroughly addressed and expressed on the poster	0	1	2	3		4	5
• Content is coherent and reads and is presented well	0	2	4	6		8	10
• Group members worked together to produce the poster	0	1	2	3		4	5
• Creative approach to topic, write-up and/or overall presentation of poster. Project stands out from the rest	0	1	2	3		4	5
The poster (10 marks)			Not achieved	Acceptable		Good	
• The format of the poster is correct according to the instructions given			0	1		2	
• Poster is well presented, on suitably sized piece of paper			0	1		2	
• Poster has appropriate illustrations			0	1		2	
• Poster flows in a logical fashion and presents information in an eye catching manner			0	1		2	
• Reference list is included and shows a variety of sources			0	1		2	
				Total		/ 65	

The assessment rubric below could be used for the above project (presentation), as taken from the UCT Chemical Engineering Mining and Mineral Processing Resource Pack.

Class presentation (Group mark)	Not achieved 0–29%	Moderate 30–49%	Adequate/ Substantial 50–69%	Outstanding 70–100%
• The content was presented in a logical and well-organised way.	0	1	2	3
• The most important and relevant content was presented.	0	1	2	3
• The visual aids were effective, appropriate and supported the presentation.	0	1	2	3
• The socio-political issues were addressed by the group and own opinions were presented.	0	1	2	3
• Appropriate conclusions were drawn.	0	1	2	3
Class presentation (Individual mark)				
• A highly enthusiastic learner; the presentation is interesting, capturing the attention.	0	1	2	3
• Accurate information was presented. It is clear that the learner has mastered the content.	0	1	2	3
• The learner is able to answer questions knowledgeably.	0	1	2	3
• The learner is able to converse in a scientific language.	0	1-2	3-4	5-6
			Total	/ 30

Weighting of topics [40 week programme]:

	Grade 10	Time
	%	Hours
Mechanics	18.75	30
Waves, Sound & Light	10.00	16
Electricity & Magnetism	8.75	14
Matter & Materials	17.50	28
Chemical Change	15.00	24
Chemical Systems	5.00	8
Teaching Time (Theory and Practical Work)	75.00	120
Time for Examinations and Control Tests	25	40

Total time = 40 hours/term x 4 terms = 160 hours per year

Physical Sciences Content (Grade 10)

This section of the CAPS document provides a complete plan for: time, topics, content, concepts and skills, practical activities, resource material and guidelines for educators. You need to consult this section of the document regularly to check whether your classroom activities fall within the requirements and objectives of the prescribed curriculum. Use the condensed work schedule below which is aligned with Section 3 and the learner's book as a pacesetter to check your progress.

Work Schedule

Term 1: 32 Hours or 9 Weeks			
Chemistry (Matter & Materials)			
Weeks	Topics	Practical Activities	Assessment
Week 1 (4 h)	Revise matter & classification (from Grade 9). The material(s) of which an object is composed. Mixtures: heterogeneous and homogeneous, pure substances: elements and compounds, names and formulae of substances. Metals, metalloids and non-metals, electrical conductors, semiconductors and insulators, thermal conductors and insulators, magnetic and non magnetic materials. States of matter and the kinetic molecular theory. Three states of matter, Kinetic Molecular Theory.	Prescribed experiment for formal assessment: Start with ice in a glass beaker and use a thermometer to read the temperature every 10 seconds when you determine the heating curve of water. Do the same with the cooling curve of water starting at the boiling point. Give your results on a graph.	Recommended Formal Assessment: 1. Control Test Recommended Informal Assessment: 1. At least two problem-solving exercises as homework and/or class work (every day, if possible cover all cognitive levels). 2. One practical activity per term. 3. At least one informal test per term.
Week 2 (4 h)	The atom: basic building block of all matter (atomic structure). Models of the atom, atomic mass and diameter, structure of the atom: protons, neutrons and electrons, isotopes, electron configuration.		
Week 3 (4 h)	Periodic table (position of the elements; similarities in electron configuration and chemical properties amongst elements in groups 1, 2, 17 and 18).	Recommended experiment for informal assessment: Flame tests to identify some metalcations and metals.	
Week 4 & 5	Chemical bonding (covalent bonding;		

(4 h)	ionic bonding; metallic bonding).		
Week 6 (4 h)	Transverse pulses on a string or spring (pulse, amplitude superposition of pulses).	Recommended experiment for informal assessment: Use a ripple tank to demonstrate constructive and destructive interference of two pulses.	
Week 7 (2 h)	Transverse waves (wavelength, frequency, amplitude, period, wave speed).		
Week 7 (cont.) (2 h)	Longitudinal waves (on a spring, wavelength, frequency, amplitude, period, wave speed, sound waves).		
Week 8 (2 h) (2 h)	Longitudinal waves (continue). Sound (pitch, loudness, quality (tone), ultrasound).		
Week 9 (3.5 h) (0.5 h)	Electromagnetic radiation (dual (particle/wave), nature of electromagnetic (EM) radiation, nature of EM radiation, EM spectrum, nature of EM as particle – energy of a photon related to frequency and wavelength). Indigenous knowledge systems Detection of waves associated with natural disasters.		

Term 2: 30 Hours or 7,5 Weeks			
Chemistry (Matter & Materials)			
Weeks	Topics	Practical Activities	Assessment
Week 1 & 2 (8 h)	Particles substances are made of (atoms and compounds; molecular substances and ionic substance form due to bonding).		
Chemistry (Chemical Change)			
Week 3 (4 h)	Physical and chemical change (separation by physical means; separation by chemical means;	Recommended experiment for informal assessment:	

	conservation of atoms and mass; law of constant composition).	Prove the law of conservation of matter by <ul style="list-style-type: none"> • reacting lead(II) nitrate with sodium iodide; • reacting sodium hydroxide with hydrochloric acid; • reacting Cal-C-Vita tablet with water. 	
Week 4 (4 h)	Representing chemical change (balanced chemical equations).		
Physics (Electricity & Magnetism)			
Week 5 (2 h)	Magnetism (magnetic field of permanent magnets, poles of permanent magnets, attraction and repulsion, magnetic field lines, earth's magnetic field, compass).	Recommended Practical Activities Informal Assessment Investigation (Physics): Pattern and direction of the magnetic field around a bar magnet.	Formal Assessment 1. Prescribed experiment in Physics on electric circuits. 2. Mid-year examinations
Week 5 (cont.) 2 h Week 6 (2 h)	Electrostatics (two kinds of charge, charge conservation, charge quantization, force exerted by charges on each other (descriptive), attraction between charged and uncharged objects (polarisation),).		Recommended Informal Assessment: 1. At least two problem-solving exercises as homework and/or class work (every day, if possible cover all cognitive levels). 2. One practical activity per term. 3. At least one informal test per term.
Week 6 (cont.) (2 h) Week 7 (4 h) Week 8 (2 h)	Electric circuits (emf, Terminal Potential Difference (terminal pd), current, measurement of voltage (pd) and current, resistance, resistors in series, resistors in parallel).	Prescribed experiment for formal assessment (Physics): Electric circuits with resistors in series and parallel – measuring potential difference and current.	
Week 8 & 9	Mid year examination.		

Term 3: 36 hours or 9 weeks			
Chemistry (Chemical Change)			
Weeks	Topics	Practical Activities	Assessment
Week 1 & 2 (8 h)	Reactions in aqueous solution (ions in aqueous solution: their interaction and effects; electrolytes; conductivity; precipitation reactions; other chemical reaction types).	Recommended experiment for informal assessment: Test water samples for carbonates, chlorides, nitrates, nitrites, pH and look at water samples under the microscope.	Formal Assessment: Recommended Project For Chemistry: 1. Purification and quality of water or Recommended project Physics: 1. Acceleration.
Week 3 & 4 (8 h)	Quantitative aspects of chemical change (Atomic mass and the MOLE CONCEPT; molecular and formula masses; determining the composition of substances; amount of substance (mole), molar volume of gases, concentration of solutions; basic stoichiometric calculations).		
Physics (Mechanics)			
Week 5 (4 h)	Vectors & scalars		2. Control test
Week 6 & 7 (8 h)	Motion in one dimension (reference frame, position, displacement and distance, average speed, average velocity, acceleration).		Informal Assessment: 1. At least two problem-solving exercises as homework and/or class work (every day, if possible cover all cognitive levels).
Week 8 & 9 (8 h)	Instantaneous speed and velocity and the equations of motion (Instantaneous velocity, instantaneous speed; description of motion in words, diagrams, graphs and equations).	Recommended experiment for informal assessment: Roll a trolley down an inclined plane with a ticker tape attached to it and use the data to plot a position vs. time graph.	2. One practical activity per term. 3. At least one informal test per term.

Term 4: 16 hours or 4 weeks			
Physics (Mechanics)			
Weeks	Topics	Practical Activities	Assessment
Week 1 & 2 (8 h)	Energy (gravitational potential energy, kinetic energy, mechanical energy, conservation of mechanical energy (in the absence of dissipative forces)).		Formal Assessment: Final examinations.
Chemistry (Chemical Systems)			
Week 3 & 4 (8 h)	The hydrosphere (Its composition and interaction with other global systems).		Informal Assessment: 1. At least two problem-solving exercises as homework and/or class work (every day, if possible cover all cognitive levels). 2. One practical activity per term. 3. At least one informal test per term.
Week 5 up to end of term	Revision and formal assessment.		

Assessment

Dear Educator, as the Programme of Assessment (PoA) is the driving force of teaching and learning in the classroom, you need to familiarise yourself with the requirements specified in the National Curriculum and Assessment Policy Statement for Physical Sciences (CAPS) document. It is important that you take notice of the significant role of practical work in the Physical Sciences.

Assessment is a continuous planned process of identifying, gathering and interpreting information about the performance of learners, using various forms of assessment

It involves four steps:

- generating and collecting evidence of achievement;
- evaluating this evidence;
- recording the findings; and
- using this information to understand and assist the learner's development to improve the process of learning and teaching.

Assessment should be both informal (Assessment for Learning) and formal (Assessment of Learning). To enhance the learning experience, learners need regular feedback from both informal and formal assessment.

Assessment is a process that measures individual learners' attainment of knowledge (content, concepts and skills) in a subject by collecting, analysing and interpreting the data and information obtained from this process to:

- enable the educator to make reliable judgements about a learner's progress;
- inform learners about their strengths, weaknesses and progress;
- assist educators, parents and other stakeholders in making decisions about the learning process and the progress of the learners.

Assessment should be mapped against the content, concepts and skills and the aims specified for Physical Sciences and in both informal and formal assessments. It is important to ensure that in the course of a school year:

- all of the subject content is covered;
- the full range of skills is included;
- a variety of different forms of assessment are used.

Informal or Daily Assessment

Assessment for learning has the purpose of continuously collecting information on a learner's achievement, that can be used to improve their learning. Informal assessment is a daily monitoring of learners' progress. This is done through observations, discussions, practical demonstrations, learner-educator conferences, informal classroom interactions, etc.

Informal assessment may be as simple as stopping during the lesson to observe learners, or to discuss with them how learning is progressing. Informal assessment should be used to provide feedback to the learners and to inform planning for teaching, but need not be recorded. It should not be seen as separate from learning activities taking place in the classroom.

Informal assessment tasks can consist of:

- homework, class work, practical investigations, experiments and informal tests.

Informal assessment tasks will assess:

- structured problem solving involving calculations, include problem-solving exercises that do not involve calculations, practical investigations, experiments, projects, scientific arguments, ability to predict, observe and explain.

Learners or educators can mark these assessment tasks.

Self-assessment and peer assessment actively involves learners in assessment. This is important as it allows learners to learn from and reflect on their own performance. The results of the informal daily assessment tasks are not formally recorded unless the educator wishes to do so. The results of daily assessment tasks are not taken into account for promotion and certification purposes. Informal, on-going assessments should be used to structure the gaining of knowledge and skills, and should precede formal tasks in the Programme of Assessment.

Formal Assessment

Formal assessment tasks form part of a year-long formal Programme of Assessment in each grade and subject. Examples of formal assessments include tests, examinations, practical tasks, projects, oral presentations, demonstrations, performances, etc. Formal assessment tasks are marked and formally recorded by the educator for progression and certification purposes. All Formal Assessment tasks are subject to moderation for the purpose of quality assurance and to ensure that appropriate standards are maintained. Formal assessment provides educators with a systematic way of evaluating how well learners are progressing in a grade and in a particular subject

Control Tests & Examinations

Control tests and examinations are written under controlled conditions within a specified period of time. Questions in tests and examinations should assess performance at different cognitive levels with an emphasis on process skills, critical thinking, scientific reasoning and strategies to investigate and solve problems in a variety of scientific, technological, environmental and everyday contexts. The table below shows recommended weighting of cognitive levels for formal assessment.

Cognitive Level	Description	Paper 1 (Physics)	Paper 2 (Chemistry)
1	Recall	15 %	15 %
2	Comprehension	35 %	40 %
3	Analysis, Application	40 %	35 %
4	Evaluation, Synthesis	10 %	10 %

The recommended weighting of cognitive levels for examinations and control tests in the Physical Sciences in Grades 10 - 12.

See Appendix 1 of the CAPS document for a detailed description of the cognitive levels.

Practical Investigations & Experiments

Practical investigations and experiments should focus on the practical aspects and the process skills required for scientific inquiry and problem solving. Assessment activities should be designed so that learners are assessed on their use of scientific inquiry skills, like planning, observing and gathering information, comprehending, synthesising, generalising, hypothesising and communicating results and conclusions.

Practical investigations should assess performance at different cognitive levels and focus on process skills, critical thinking, scientific reasoning and strategies to investigate and solve problems in a variety of scientific, technological, environmental and everyday contexts. The CAPS document distinguishes between a practical investigation and an experiment: an experiment is conducted to verify or test a known theory; an investigation is an experiment that is conducted to test a hypothesis i.e. the result or outcome is not known beforehand.

Requirements for Grade 10 Practical Work

Two prescribed experiments for formal assessment (**one** Chemistry and **one** Physics experiment) and **one** project on either Physics or Chemistry. This gives a total of **three** formal assessments in practical work in Physical Sciences. It is recommended that Grade 10 learners also do **four** experiments for informal assessment (**two** Chemistry and **two** Physics experiments).

A summary to use as a check list for practical work in Grade 10:

Practical Work	Chemistry	Term	Mark (x)	Physics	Term	Mark (x)
Prescribed Experiments (Formal Assessment)	1	1		1	2	
Experiments (Informal Assessment)	2	1, 2, 3 or 4		2	1, 2 or 3	
Project (Formal Assessment)	One either Physics or Chemistry	3				
Total		7 practical activities				

Projects

As taken from CAPS, "a project is an integrated assessment task that focuses on process skills, critical thinking and scientific reasoning as well as strategies to investigate and solve problems in a variety of

scientific, technological, environmental and everyday contexts. This requires a learner to follow the scientific method to produce either a poster, a device, a model or to conduct a practical investigation.”

A project will entail only one of the following:

- i. Making of a scientific poster
- ii. Construction of a device e.g. electric motor
- iii. Building a physical model in order to solve a challenge you have identified using concepts in the FET Physical Sciences curriculum
- iv. Practical investigation

Note:

The assessment tools used, specifying the assessment criteria for each task, will be dictated by the nature of the task and the focus of assessment.

Assessment Tools

You use the tool to record information during an assessment. Assessment tools can be:

- Check lists
- Assessment grids/sheets
- Rubrics
- Observation books or notebooks
- Completed tasks, assignments of worksheets
- Conferencing or interviews
- Self or Peer Assessment Sheets
- Recordings, photographs, written descriptions
- Portfolios

Before you use the tool the learners must know:

- When he/she is to be assessed
- What will be assessed
- How she/he will be assessed
- The consequences of the assessment
- The expected mode for response (written, spoken, practical)

After using the tool, the educator needs to answer the following question:

- Were the criteria used adequate to assess the outcome, and were the levels appropriate?
- Is appropriate feedback given to learners?
- Are learning difficulties identified and action planned?
- What happens to the product?
- What feedback follow-up action is needed?
- Has the integrating function been addressed?
- What learner appeal process exists?
- How will assessment inform further teaching/learning?

Rubrics

A rubric is an assessment tool which defines different levels of performance. It can be used for assessing concepts and process skills during informal and formal assessment, and for practical work. Rubrics aim to make assessment more objective and consistent. Some of the advantages of using rubrics are:

- **Learners** become aware of the expectations of educators
- **Educators** become aware of learners' progress and potential
- Enhance greater learner involvement
- Learners are more focused and self-directed

Examples of rubrics:

1. Assessment of Practical Work

1.1 Planning and organising experimental investigations to test hypotheses

Criteria	High (3)	Medium (2)	Low (1)
Plan should reflect process of identification of variables, control of variables, range of conditions, ways in which the experiment could be improved, awareness of inaccuracies, offering of a conclusion.	Able to plan independently an experiment in which all variables are identified and controlled as necessary. Able to suggest ways in which the experiment could be improved.	Able to plan independently an experiment to test a hypothesis in which most of the variables are identified and controlled as necessary.	Able to plan a one-step experiment to test the hypothesis.

1.2 Following instructions and manipulations

Criteria	High (3)	Medium (2)	Low (3)
Accurately following a sequence of written/verbal instructions.	Following a sequence of instructions including branched instructions.	Can complete an experiment by following a sequence of instructions.	Able to follow a single written, diagrammatic or verbal instruction.
Selecting/using the appropriate apparatus.	Select in advance all the apparatus needed to execute a particular experiment and be able to use it.	Able to select/use most of the apparatus necessary; some more specialized equipment may still be needed.	Able to select/use only the most basic apparatus.
Manipulative skills include correct and safe handling of apparatus and material.	Able to use all apparatus and material correctly and safely.	Use most of the apparatus and material safely.	Able to use only the most basic equipment.

1.3 Making accurate observations and measurements, being aware of possible sources of error

Criteria	High (3)	Medium (2)	Low (1)
Accuracy, completeness and relevance of observations.	Able to make a complete sequence of observations in a given situation and is aware of a number of sources of error.	Able to make a range of observations in a given situation and is able to suggest one possible source of error.	Able to make a single observation and more if prompted, e.g.: What did you observe regarding colour and smell or temperature in test tube?
Selection of measurement instrument, performance of measuring operation and reading scales.	Able to read a variety of scales as accurately as the scale permits.	Able to read a scale to the nearest division.	Able to read scales within \pm one numbered scale division.

Criteria for check lists could be more differentiated when directed towards specific experiments in Chemistry or Physics.

Regarding the scope of observations properties, similarities and differences taking place in colour, hardness, mass, relative speed, size, smell, sound, state, temperature, texture, volume, voltages could be listed.

The performance of measuring which might be used for assessment could be listed as:

1. Is the instrument capable of measuring the correct amount?
2. Was the correct range of the instrument selected?
3. Were the necessary precautions taken to ensure that the measurements will be valid?
4. Are measurements repeated or checked?
5. Are readings made with due regard for parallax?
6. Is the scale reading translated to the correct magnitude and are the correct units assigned?

1.4 Recording accurately and clearly the results of experiments

Criteria For Processing Data	High (3)	Medium (2)	Low (1)
All the observations are described accurately and completely. Appropriate methods (written, tables, diagrams) used to record observations and measurements.	Able to draw fully labelled diagrams to record observations. Able to record results in neat tables with appropriate headings and units, with all measurements recorded as well as derived quantities.	Data recorded as an ordered set of statements, or in a table some data and units omitted.	Information recorded as a prose account, as a sequence of statements. Able to record data in a pre-prepared table.

1.5 Presentation of data in graphic form

Criteria	Excellent 3	Good 2	Incomplete 1
Acceptable scale. X-axis correctly labelled. Units on X-axis. Y-axis correctly labelled. Units on Y-axis. Points correctly marked. Points correctly linked. Contradictory results "normalised". Appropriate subtitle.	All the criteria could be met without assistance.	All criteria could be met with help.	Graphs could only be drawn with pre-prepared axes, with a lot of assistance.

1.6 Drawing conclusions and making generalisations from experiments

Criteria	High (3)	Medium (2)	Low (1)
Valid deductions from results.	Able to identify patterns or relationships and explain fundamental principles, verbal or in mathematical terms.	Able to identify a pattern, simple or trend in the relationship between two variables. Perform simple calculations of a derived quantity.	Classifications of observations and recognition of similarities and differences. Able to explain a simple observation.

End-of-Year Examinations: Grade 10 (Internal)

The end-of-year examination papers in Grade 10 will be set, marked and moderated internally, unless otherwise instructed by provincial departments of education. The examination will consist of two papers. The table below shows the weighting of questions across cognitive levels and the specification and suggested weighting of the content.

Grade 10								
Paper	Content	Marks	Total Marks/ Paper	Duration (Hours)	Weighting of Questions Across Cognitive Levels			
					Level 1	Level 2	Level 3	Level 4
Paper1: Physics Focus	Mechanics		75	150	2	15.00%	35.00%	40.00%
	Waves, Sound & Light		40					
	Electricity & Magnetism		35					

Paper 2: Chemistry Focus	Chemical Change	60	150	2	15.00%	40.00%	35.00%
	Chemical Systems	20					
	Matter & Materials	70					

Weighting of questions across cognitive levels, the specification and suggested weighting of the content for the Grade 10 end-of-year examination:

Assessment plan and weighting of tasks in the programme of assessment for Grade 10:

<p>Term 1 Prescribed experiment: (20% of year mark) or 20 marks. Control Test: (10% of year mark) 10 marks. Total: 30 marks</p>
--

<p>Term 2 Prescribed experiment: (20% of year mark) or 20 marks. Mid-Year Examination: (20% of year mark) or 20 marks. Total: 40 marks</p>
<p>Assessment Tasks: (25% of final mark). Total: 100 marks</p>

<p>Term 3 Project: Any one of: poster/construction of device/building a model/practical investigation 20 marks. Control Test: 10 marks. Total: 30 marks</p>
<p>Final Mark: (100%) 400 marks</p>

<p>Term 4: Final Examination: Paper 1 x 150 marks. Paper 2 x 150 marks. Total: 300 marks</p>
<p>End-of-Year Assessment: (75% of final mark) 300 marks</p>

Recording and Reporting

Recording is a process in which the educator documents the level of a learner's performance in a specific assessment task. It shows learner progress towards the achievement of the knowledge and skills as prescribed in the Curriculum and Assessment Policy Statements. Records of learner performance should provide evidence of the learner's conceptual progression within a grade and her / his readiness to progress or be promoted to the next grade. Records of learner performance should also be used to verify the progress made by educators and learners in the teaching and learning process.

Reporting is a process of communicating learner performance to learners, parents, schools, and other stakeholders. Learner performance can be reported through report cards, parents' meetings, school visitation days, parent-educator conferences, phone calls, letters, class or school newsletters, etc. Educators in all grades report in percentages against the subject. The various achievement levels and their corresponding percentage bands are as shown in the table below.

Note: The seven point scale should have clear descriptions that give detailed information for each level. Educators will record actual marks against the task by using a record sheet, and report percentages against the subject on the learners' report card.

Codes and Percentages for Reporting in Grades R - 12:

Rating Code	Description of Competence	Percentage
7	Outstanding Achievement	80-100
6	Meritorious Achievement	70-79
5	Substantial Achievement	60-69
4	Adequate Achievement	50-59
3	Moderate Achievement	40-49
2	Elementary Achievement	30-39
1	Not Achieved	0-29

Schools are required to provide quarterly feedback to parents on the Programme of Assessment using a formal reporting tool such as a report card. The schedule and the report card should indicate the overall level of performance of a learner.

Skills for physical sciences learners

This section requires you to reference Appendix 2 of the CAPS document, as it recommends that the skills it covers be incorporated in lessons in Grade 10, in order to sharpen the skills necessary for successful teaching and learning. Skills covered are scientific notation, conversion of units, changing the subject of the formula, rate and its applications in physics and chemistry, direct and inverse proportions, fractions and ratios, the use and meaning of constants in equations, skills needed for practical investigations (observation, precautions, data collection, data handling, tables, general types of graphs, analysis, writing conclusions, writing a hypothesis, identifying variables - for example independent, dependent and control variable), models in science, safety data, and basic trigonometry skills,

Overview of Chapters

Skills for science

This chapter looks at the skills that students need to be able to succeed in science. The contents of this chapter are intended to be incorporated into the teaching of the other chapters. This chapter covers both mathematical skills and laboratory skills.

This chapter begins by explaining the huge role measuring plays in the Physical Sciences and the importance of units. Examples given illustrate that experiment and observation becomes meaningful when expressed in a quantity and its particular unit. The SI unit system with its seven base SI units is introduced. Details are provided for the correct way to write units and their abbreviations. For example: the SI unit for length is meter (lower case) and the abbreviation is “m”, while the volume of a liquid is measured in litre “ℓ”. When a unit is named after a person, then the symbol is a capital letter. The ‘newton’ is the unit of force named after Sir Isaac Newton and its symbol is “N”. When writing a combination of base SI units, place a centred dot (·) between the base units used. Metres per second is correctly written as “ $m \cdot s^{-1}$ ”.

Currently learners are expected to round off correctly to 2 decimal places. The text in the learner’s book illustrates the big difference to the answer when rounding off digits during a calculation. As an educator you often need to remind your learners only to round off the final answer. Learners also need to be able to write and translate data into the correct units and dimensions using scientific notation. To develop learners’ skills to do conversions and calculations use the table of unit prefixes, conversion diagrams and worked examples. Fractions, ratios, proportion and rates are all explained as well as the use of trigonometry.

This chapter then continues with skills in the laboratory. Important safety information is given, as well as the laboratory rules. Learners are encouraged to always follow these rules to work safely in the laboratory. Teachers are advised to print out relevant safety data sheets for their learners and to encourage their learners to do this for each new chemical they work with.

Classification of matter

To link to Grade 9, matter is classified according to its different properties. The diagram below summarises the sequence in which content, concepts and skills are developed in this chapter.

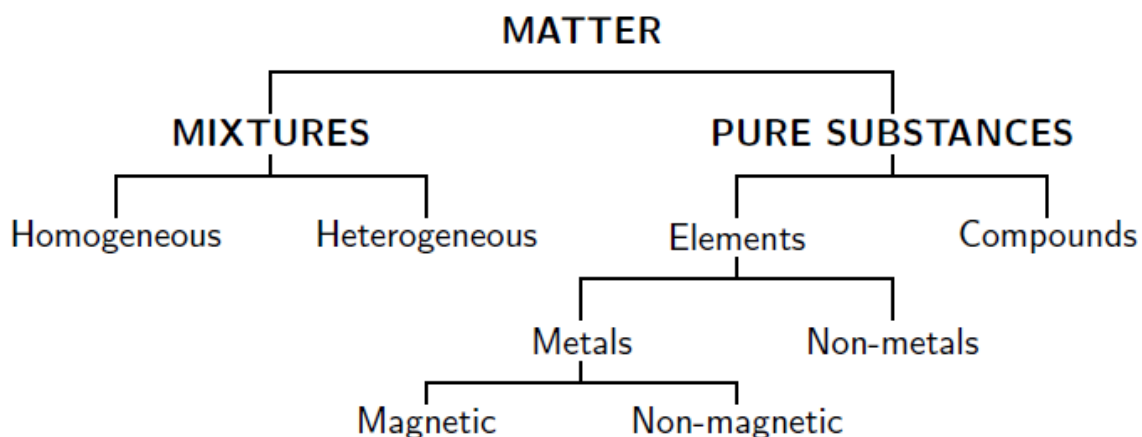

Diagram: the Classification of Matter

The terms: mixture, heterogeneous and homogeneous mixtures are defined and explained in a learner-friendly way. To clarify concepts and support understanding, a lot of interesting examples linked to everyday lifestyle are given. For example, cereal in milk is described as a heterogeneous mixture, as the cereal is not evenly distributed in the milk and is visible.

In the section on pure substances, learners will learn about: elements, compounds and the periodic table of elements, as well as to decide what the difference is between a mixture and a compound by using molecular models. The time spent on the guidelines provided for naming compounds and the exercise to consolidate understanding will be worthwhile! You ought to find that the learners will easily understand the text explaining the concepts: metals, semi-metal, non-metals, electrical conductors, semi-conductors and insulators, thermal conductors and insulators as well as magnetic and non-magnetic materials. The text also elaborates on where the specific properties of the listed materials are used in buildings, industrial and home environments as well as in animals and humans. Point out to the learners that as students of the Physical Sciences they need to understand how the physical environment works in order to benefit from it.

The learners need to engage in the practical investigations listed in this chapter to strengthen their practical ability in a “hands on” way.

Investigate:

- Electrical conductivity
- Thermal conductivity
- Magnetism

The detailed summary at the end of the chapter and the summary exercises provide a useful self-assessment check list for the learner and the educator, to make sure that all aspects have been effectively addressed and learnt.

States of matter and the kinetic molecular theory (KMT)

Educators should not skip this section assuming that learners know the KMT because they have been exposed to it in previous grades. As an educator you should challenge the learners to move mentally between the three ways of thinking and talking about matter, as shown in the diagram above.

Use the learner’s book to revise the following concepts:

States of Matter

- Matter exists in one of three states: solid, liquid and gas.
 - a solid has a fixed shape and volume;
 - a liquid takes on the shape of the container that it is in;
 - a gas completely fills the containers that it is in.
- Matter can change between these states by either adding heat or removing heat.
- Melting, boiling, freezing, condensation and sublimation are processes that take place when matter changes state.

A formal experiment on heating and cooling curves of water is undertaken in this section. This experiment aims to help learners understand what temperature changes occur when a substance is heated or cooled.

The kinetic theory of matter states that:

- all matter is composed of particles which have a certain amount of energy, which allows them to move at different speeds depending on the temperature (energy);

- there are spaces between the particles and also attractive forces between particles when they come close together.

In Grade 10 the learners should understand the kinetic theory to assist them in explaining the macroscopic properties of matter, and why substances have different boiling points, densities and viscosities.

The atom

In this section the idea that matter is made of very small particles (atoms) is introduced and learners are guided in understanding the microscopic nature of matter. Studying the atomic models illustrates that scientific knowledge changes over time as scientists acquire new information.

Studying the atomic models of Dalton, Thomson, Rutherford, Chadwick and Bohr contribute to form a 'picture' of how an atom looks, based on evidence available at that stage. The concepts related to the structure of the atom: protons, neutrons and electrons, isotopes, atomic number and atomic mass are explained in a way that learners will understand. To consolidate learning, learners need to engage in studying the worked examples and do the exercises. By taking part in the suggested group discussion activities, learners have the opportunity to develop critical thinking skills and express themselves using the scientific language. The effective use of diagrams clarifies abstract concepts, such as electron configuration. The text urges learners to understand electron configuration, as valence electrons of the atoms will determine how they react with each other.

The periodic table

The CAPS document requires that learners understand the arrangement of elements in increasing atomic number, and show how periodicity of the physical and chemical properties of the elements relates to electronic structure of the atoms in the periodic table. The content of this section in the learner book will enable learners to understand the underpinning concepts and to develop the skill to use the periodic table to extract data.

For example:

- the lower the ionisation energy, the more reactive the element will be
- how to predict the charge on cations and anions by using the periodic table

Chemical bonding

This section explores the forming of new substances with new physical and chemical properties when different combinations of atoms and molecules join together. This process is called chemical bonding, one of the most important processes in chemistry. The type of bond formed depends on the elements involved. Three types of chemical bonding: covalent, ionic and metallic bonding are discussed.

Covalent bonds form when atoms of non-metals share electrons. Why and how atoms join is described and explained by using Lewis dot diagrams to represent the formed molecules. Revision of names and formulae of several compounds is presented.

Ionic bonds form when electrons are transferred. Ionic bonding takes place when the difference in

electronegativity between the two atoms is more than 1.7. The cations and anions that form attract each other with strong electrostatic forces. Details of how ionic compounds form is clarified with Lewis notation. When learners become familiar with the diagram of the crystal lattice arrangement in an ionic compound such as NaCl they will be able to derive the properties of ionic compounds.

Metallic bonding is the electrostatic attraction between the positively charged atomic nuclei of metal atoms and the delocalised electrons in the metal. The unique properties of metals as a result of this arrangement are described.

Transverse pulses

Transverse pulses on a string or spring are discussed, but first the questions are asked: What is a medium? What is a pulse? The following terms related to transverse pulse are introduced, defined and explained: position of rest, pulse length, amplitude and pulse speed. When a transverse pulse moves through the medium, the particles in the medium only move up and down. This important concept is illustrated by a position vs. time graph. When learners engage in doing the investigation, drawing a velocity-time graph and studying the worked example, they will get to grips with the concepts. When two or more pulses pass through the same medium at the same time, it results in constructive or destructive interference. This phenomenon is explained by superposition, the addition of amplitudes of pulses.

Transverse waves

A transverse wave is a wave where the movement of the particles of the medium is perpendicular to the direction of propagation of the wave. Concepts addressed include: wavelength, amplitude, frequency, period, crests, troughs, points in phase and points out of phase, the relationship between frequency and period, i.e.

$$f = \frac{1}{T} \quad \text{and} \quad T = \frac{1}{f}, \quad \text{the speed equation,} \quad v = f\lambda.$$

Longitudinal waves

In a longitudinal wave, the particles in the medium move parallel to the direction in which the wave moves. It is explained how to generate a longitudinal wave in a spring. While transverse waves have peaks and troughs, longitudinal waves have compressions and rarefactions. A compression and a rarefaction is defined, explained and illustrated. Similar to the case of transverse waves, the concepts wavelength, frequency, amplitude, period and wave speed are developed for longitudinal waves. Problems set on the equation of wave speed for longitudinal waves, $v = f\lambda$, concludes this section.

Sound

Sound is a longitudinal wave. The basic properties of sound are: pitch, loudness and tone. Illustrations are used to explain the difference between a low and a high pitch and a soft and a loud sound. The speed of sound depends on the medium the sound is travelling in. Sound travels faster in solids than in liquids, and faster in liquids than in gases. The speed of sound in air, at sea level, at a temperature of 21°C and under normal atmospheric conditions, is $344 \text{ m}\cdot\text{s}^{-1}$. Frequencies from 20 to 20 000 Hz is audible to the human ear. Any sound with a frequency below 20 Hz is known as an infrasound and any sound with a frequency above 20 000 Hz is known as an ultrasound.

The use of ultrasound to create images is based on the reflection and transmission of a wave at a boundary. When an ultrasound wave travels inside an object that is made up of different materials such as the human body, each time it encounters a boundary, e.g. between bone and muscle, or muscle and fat, part of the wave is reflected and part of it is transmitted. The reflected rays are detected and used to construct an image of the object. Ultrasound in medicine can visualise muscle and soft tissue, making them useful for scanning the organs, and is commonly used during pregnancy. Ultrasound is a safe, non-invasive method of looking inside the human body.

Electromagnetic radiation

Some aspects of the behaviour of electromagnetic radiation can best be explained using a wave model, while other aspects can best be explained using a particle model. The educator can use the descriptions and diagrams in the text to explain:

- how electromagnetic waves are generated by accelerating charges;
- that an electric field oscillating in one plane produces a magnetic field oscillating in a plane at right angles to it, and so on; and
- how EM waves propagate through space, at a constant speed of $3 \times 10^8 \text{ m} \cdot \text{s}^{-1}$.

The colourful visual representation of the electromagnetic spectrum as a function of the frequency and wavelength also showing the use of each type of EM radiation, will assist learners to connect physical concepts to real life experiences. The penetrating ability of the different kinds of EM radiation, the dangers of gamma rays, X-rays and the damaging effect of ultra-violet radiation on skin and radiation from cell-phones are discussed.

The particle nature of EM radiation is stated and the concept photon is defined. The energy of a photon is calculated using the equation: $E = hf$ where $h = 6,63 \times 10^{-34} \text{ J} \cdot \text{s}$ is Planck's constant, f = frequency, and where $c = 3 \times 10^8 \text{ m} \cdot \text{s}^{-1}$ is the speed of light in a vacuum. Learners can calculate the energy of an ultraviolet photon with a wavelength of 200 nm by using the equations given.

The particles that substances are made of

Learners will learn that all objects are made of matter, and that different objects are made of different types of matter or materials. These different properties will be explained by studying material's microscopic structure (the small parts that make up the material). We will explore the smallest building blocks of matter, atoms, their unique properties and how they interact and combine with other atoms.

Revision of concepts related to compounds, their chemical and empirical formulae, and models to represent compounds will assure that all learners have the necessary prior knowledge to understand new concepts.

Physical and chemical change

This section starts by distinguishing between physical and chemical changes of matter. Matter does not change during a physical change, it is the arrangement of compounds that change. Matter changes during chemical changes through decomposition and synthesis reactions. Physical and chemical changes are compared with respect to the arrangement of particles, conservation of mass, energy changes and

reversibility. The role of intermolecular forces during phase changes (a physical change) is highlighted. Understanding of concepts is enhanced by examples which include diagrams, experiments and investigations.

Representing chemical change

As a Physical Sciences educator you will welcome this section as it will bridge the gap learners might have in conceptual understanding and skills to represent chemical change. The content revised includes: common chemical symbols and writing chemical formulae. This knowledge is then used in balancing chemical equations by applying the law of conservation of mass. The four labels used to represent the state (phase) of compounds in the chemical equation are:

- (g) for gaseous compounds
- (l) for liquids
- (s) for solid compounds and
- (aq) for an aqueous (water) solution

Learners will develop the skills to balance chemical equations when they study and apply the steps discussed in the text. Learners need to do the proposed investigation (possibly multiple investigations) and work through the examples and exercises to assess understanding and consolidate learning.

Magnetism

Magnetism is a force exerted by magnetic objects without touching each other. A magnetic object is surrounded by a magnetic field, a region in space where a magnet or object made of magnetic material will experience a non-contact force. Electrons inside any object have magnetic fields associated with them. The way the electrons' magnetic fields line up with each other explains magnetic fields in ferromagnetic materials (e.g. iron), magnetisation, permanent magnets and polarity of magnets. These concepts are explored with descriptions, diagrams and investigations.

Magnets have a pair of opposite poles, north and south. Like poles of a magnet repel; unlike poles attract. It is not possible to isolate north and south poles - even if you split a magnet, you only produce two new magnets. The magnetic field line around a bar magnet can be visualised using iron filings and compass needles. Learners need to be reminded that the field is three dimensional, although illustrations depict the fields in 2D. To show the shape, size and direction of the magnetic fields different arrangements of bar magnets are investigated and illustrated.

The pattern of the Earth's magnetic field is as if there is an imaginary bar magnet inside the Earth. Since a magnetic compass needle (a north pole) is attracted to the south pole of a magnet, and magnetic field lines always point out from north to south, the earth's pole which is geographically North is magnetically actually a south pole. The Earth has two north poles and two south poles: geographic poles and magnetic poles. The geographic North Pole, which is the point through which the earth's rotation axis goes, is about 11,5° away from the direction of the Magnetic North Pole (which is where a compass will point). Learners are made aware of the importance of the earth's magnetic field acting as a shield to stop electrically charged particles emitted by the sun from hitting the earth and us. Charged particles can damage and cause interference with telecommunications (such as cell phones).

Solar wind is the stream of charged particles (mainly protons and electrons) coming from the sun. These particles spiral in the earth's magnetic field towards the poles. If they collide with particles in the earth's atmosphere they sometimes cause red or green lights, or a glow in the sky which is called the aurora, seen at the north and south pole.

Electrostatics

Electrostatics is the study of electric charge which is static (not moving). Remind learners that all objects surrounding us (including people!) contain large amounts of electric charge. There are two types of electric charge: positive charge and negative charge. If the same amounts of negative and positive charge are brought together, they neutralise each other and there is no net charge; the object is neutral. However, if there is a little bit more of one type of charge than the other on the object, then the object is electrically charged. The concepts: positively charged (an electron deficient) and negatively charged (an excess of electrons) are explained mathematically and with illustrations

The unit in which charge is measured is coulomb (C). A coulomb is a very large charge. In electrostatics we often work with charge in microcoulombs ($1\mu C=1\times 10^{-6}C$) and nanocoulombs ($1nC=1\times 10^{-9}C$).

Objects may become charged by contact or when rubbed by other objects (tribo-electric charging). Charge, like energy, cannot be created or destroyed - charge is conserved. When a ruler is rubbed with a cotton cloth, negative charge is transferred from the cloth to the ruler. The ruler is now negatively charged and the cloth is positively charged. If you count up all the positive and negative charges at the beginning and the end, there is still the same amount, i.e. total charge has been conserved!

An electrostatic force is exerted by charges on each other. The electrostatic force between:

- like charges are repulsive
- opposite (unlike) charges are attractive.

The closer together the charges are, the stronger the electrostatic force between them.

Perform the suggested experiment to test that like charges repel and unlike charges attract each other. The electrostatic force also determines the arrangement of charge on the surface of conductors, because charges can move inside a conductive material. On a spherical conductor the repulsive forces between the individual like charges cause them to spread uniformly over the surface of the sphere, however, for conductors with non-regular shapes, there is a concentration of charge near the point or points of the object.

Conductors and insulators: All the matter and materials on earth are made up of atoms. All atoms are electrically neutral i.e. they have the same amounts of negative and positive charge inside them. Some materials allow electrons to move relatively freely through them (e.g. most metals, the human body). These materials are called conductors. Other materials do not allow the charge carriers, the electrons, to move through them (e.g. plastic, glass). The electrons are bound to the atoms in the material. These materials are called non-conductors or insulators. There can be a force of attraction between a charged and an uncharged neutral insulator due to a phenomenon called polarisation. The latter is explained in terms of the movement of polarised molecules in insulators. Learners are also introduced to the electroscope, a very sensitive instrument which can be used to detect electric charge.

Electric circuits

This chapter begins by looking at the concept of voltage and potential difference. The concept of charge and current is then introduced followed by resistance. Several worked examples are given to assist learners in coming to grips with these important concepts.

The text guides learners to gain a better understanding of potential difference. They need to know that charges will not move unless there is a force provided by the battery in the circuit. The amount of work done to move a charge from one point to another point equals the change in electric potential energy. Note: it is a difference between the value of potential energy at two points, therefore potential difference is measured between or across two points. Potential difference is defined as: the difference in electrical potential energy per unit charge between two points. The unit of potential difference is volt (V). 1 volt = 1 joule (energy)/1 coulomb (charge). Electrical potential difference is also called voltage.

Current is defined as the amount of charges that move past a fixed point in a circuit in one second. Use the picture in the learners' book and description to explain to learners that the charges in the wires can only be pushed around the circuit by a battery. When one charge moves, the charges next to it also move. The current flowing can be calculated with the equation: $I = \frac{Q}{t}$, where I is the symbol for current measured in amperes (A) and Q the symbol for charge measured in coulomb (C). One ampere is one coulomb of charge moving in one second.

The concepts of potential difference across resistors connected in parallel and in series in electric circuits are explored in depth. Diagrams show the points between which the potential difference is measured, how the voltmeter (an instrument that measures potential difference) is connected and the voltmeter readings obtained. The concept *emf* as the voltage measured across the terminals of a battery is developed in a similar way.

The voltage and current in series and parallel circuits are investigated using a voltmeter and ammeter respectively to measure the relevant quantity across or through a given circuit element.

Resistance slows down the flow of current in a circuit. On a microscopic level, resistance is caused when electrons moving through the conductor collide with the particles of which the conductor (metal) is made. When they collide, they transfer kinetic energy. The electrons therefore lose kinetic energy and slow down. This leads to resistance. The transferred energy causes the resistor to heat up. We use the symbol R to show resistance and it is measured in units called ohms with the symbol Ω . $Ohm = V \cdot A^{-1}$

An important effect of a resistor is that it converts electrical energy into other forms of heat energy. Light energy is a by-product of the heat that is produced.

Learners need to see the bigger picture and be able to explain why batteries go flat. In the battery, chemical potential energy (chemical reactions) is converted to electrical energy (which powers the electrons to move through the circuit). Because of the resistance of circuit elements, electrical energy is converted to heat and light. The battery goes flat when all its chemical potential energy has been converted into other forms of energy.

Reactions in aqueous solution

Many reactions in chemistry and all reactions in living systems take place in water (or aqueous solution). In almost all these reactions ions are present. We explore:

- ions in aqueous solution;
- electrical conductivity; and
- the three main types of reactions that occur in aqueous solution, namely precipitation, acid-base and redox reactions.

Ions in aqueous solution

Learners need to understand why water is a polar molecule, to apply their knowledge in further discussions. It is this unique property that allows ionic compounds to dissolve in water. In plants and animals water is the carrier of these dissolved substances making life possible. The process of dissociation is thoroughly explained using words, a definition, image and an equation. The equation for the dissolution of sodium chloride is:

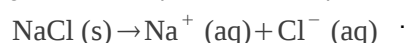

Electrolytes, ionisation and conductivity

Concepts are explored using: definitions, equations and experiments.

- Conductivity is a measure of the ability of water to conduct an electric current. The more ions in the solution, the higher its conductivity.
- An electrolyte is a material that increases the conductivity of water when dissolved in it. Electrolytes are divided into strong and weak electrolytes.
- A non-electrolyte is a material that does not increase the conductivity of water when dissolved in it. The substance that goes into a solution becomes surrounded by water molecules separate from each other, but no chemical bonds are broken. This is a physical change. In the example of sugar dissolving in water the reaction is reversible because sugar is only partially soluble in water and comes out of solution very easily.

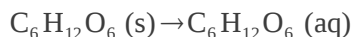

Step by step guidance is given to understand precipitation reactions and to apply the knowledge when testing for the anions: chloride, bromide, iodide, sulphate and carbonate.

Acid-base and redox reactions also take place in aqueous solutions. When acids and bases react, water and a salt are formed. An example of this type of reaction is:

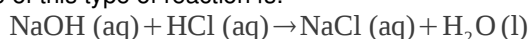

Redox reactions involve the exchange of electrons. One ion loses electrons and becomes more positive, while the other ion gains electrons and becomes more negative. These reactions will be covered in more detail in Grade 11.

Quantitative aspects of chemical change

As introduction to this topic, educators need to spend time on explanations, so that learners can acknowledge the very small size of atoms, molecules and ions. In the reaction between iron and sulphur, every iron (Fe) atom reacts with a single sulphur (S) atom to form one molecule of iron sulphide (FeS). But how will we know how many atoms of iron are in a small given sample of iron, and how much sulphur is needed to use up the iron? Is there a way to know what mass of iron sulphide will be produced? Concepts to be developed to answer these questions are: relative atomic mass, the mole, molar mass, Avogadro's

constant and composition of substances. Learners need to understand and manipulate the equation below to calculate the number of moles, mass or molar mass of a substance.

$$n = \frac{m}{M}$$

When learners engage in the suggested group work: “Understanding moles, molecules and Avogadro's number” and the multiple exercises set on moles and empirical formulae and molar concentration of liquids, they will be able to do basic stoichiometric calculations to determine the theoretical yield of a product in a chemical reaction, when you start with a known mass of reactant.

Vectors and scalars

Physics describes the world around us. In mechanics we study the motion of objects and the related concepts of force and energy. It takes two qualities: size and direction, to describe force and motion. A vector is such a quantity that has both magnitude and direction. Vectors are not Physics but vectors form a very important part of the mathematical description of Physics. In this section, learners will develop the understanding of the concepts of vectors. They need to master the use of vectors to enable them to describe physical phenomena (events).

The text will direct learners to:

- know and explain with examples the differences between vectors and scalars;
- define vectors in words, with equations, mathematical and graphical representations;
- express direction using different methods as: relative directions (right, left, up, down), compass directions (North, South, East, West) and bearing (in the direction 030);
- draw vectors;
- explore the properties of vectors like equal vectors and negative vectors;
- add, subtract and multiply with vectors;
- define the resultant vector in words, graphically and by calculation; and
- apply their understanding by doing the exercises.

Motion in one dimension

This section explains how things move in a straight line or scientifically move in one dimension. Three ideas describe exactly how an object moves.

They are:

1. Position or displacement which tells us exactly where the object is;
2. Speed or velocity which tells us exactly how fast the object's position is changing or more familiarly, how fast the object is moving; and
3. Acceleration, which tells us exactly how fast the object's velocity is changing.

When studying motion, you need to know where you are, your position relative to a known reference point. The concept frame of reference, defined as a reference point combined with a set of directions (east, west, up, down) is explained with illustrated examples. The illustrations on position are linked with learners' everyday experience, making it easy for them to describe position and to understand that position can be positive or negative, relative to a reference point. The displacement of an object is defined as its change in position, a vector quantity, mathematically described as Δx . In Mathematics and Science the symbol

Δ (delta) indicates a change in a certain quantity. For example, if the initial position of a car is x_i and it moves to a final position of x_f , then the displacement is $x_f - x_i$. Displacement is written as:

$$\Delta x = x_f - x_i$$

Each of the concepts: speed, average velocity, instantaneous velocity and acceleration that describe motion are developed in words; definitions are stated, and suitable examples are discussed using illustrations. Equations are also used to interpret motion and to solve problems. Graphs, another way of describing motion, is also introduced in this section. The three graphs of motion: position vs. time, velocity vs. time and acceleration vs. time are discussed and presented simultaneously, starting with a stationary object. Learners will benefit by the way in which the content is developed, showing that graphs are just another way of representing the same motions previously described in words and diagrams. The text guides learners to extract information about movement from graphs by calculating the gradient of a straight line and the area under a graph.

The multiple examples discussed will clarify concepts developed, and by doing the exercises learners can assess their understanding. This section ends with the equations of motion, another way to describe motion. The curriculum prescribes that learners must be able to solve problems set on motion at constant acceleration. The text familiarises learners with these equations, and provides ample examples and exercises of problems to solve, set on real life experiences.

Mechanical energy

Gravitational potential energy is defined as the energy of an object due to its position above the surface of the Earth. In equation form gravitational potential energy is defined as:

$$E_p = mgh$$

m = mass (measured in kg), g = gravitational acceleration ($9,8 \text{ m} \cdot \text{s}^{-2}$) and h = perpendicular height from the reference point (measured in m).

Refer to the chapter on Skills for science. By showing that the units $\text{kg} \cdot \text{m} \cdot \text{s}^{-2}$ are equal to J, and mixing units and energy calculations will assist learners to be more watchful when solving problems to convert given data to SI base quantities and units.

Kinetic energy is the energy an object has because of its motion. The kinetic energy of an object can be determined by using the equation:

$$E_k = \frac{1}{2} mv^2$$

In words, mechanical energy is defined as the sum of the gravitational potential energy and the kinetic energy, and as an equation:

$$E_M = E_p + E_k = mgh + \frac{1}{2} mv^2$$

Both the laws of conservation of energy and conservation of mechanical energy are states.

To solve problems the latter is applied in the form:

$$U_{top} = U_{bottom}$$
$$E_{P_{top}} + E_{K_{top}} = E_{P_{bottom}} + E_{K_{bottom}}$$

To assess their degree of understanding of the content and concepts, learners are advised to engage in studying the worked examples and do the set problems.

The hydrosphere

The hydrosphere is made up of freshwater in rivers and lakes, the salt water of the oceans and estuaries, groundwater and water vapour. This section deals with how the hydrosphere interacts with other global systems. On exploring the hydrosphere, an investigation is proposed and guidance is given on how to choose the site, collect, and interpret the data. The very important function that water plays on our planet is highlighted, as well as threats to the hydrosphere. To cultivate an attitude of caring and responsibility towards the hydrosphere, learners are encouraged to engage in the proposed discussions on creative water conservation and investigations: how to build dams and to test the purity of water samples. As an educator you will appreciate the hints supplied for a project on water purification.

Units used in the book

This chapter consists of tables that show units used in the books, including their quantity, symbol, unit and S.I. Units.

Exercise Solutions

Solutions to the exercises are covered in this chapter.

Chapter solutions

Chapter 1. Skills for science

Exercise 1-1:

1. Carry out the following calculations:

- a) $1,63 \times 10^5 + 4,32 \times 10^6 - 8,53 \times 10^5$
- b) $7,43 \times 10^3 \div 6,54 \times 10^7 \times 3,33 \times 10^5$
- c) $6,21434534 \times 10^{-5} \times 3,2555 \times 10^{-3} + 6,3 \times 10^{-4}$

Solution:

- a) $3,63 \times 10^6$
- b) 37,83
- c) $6,3 \times 10^{-4}$

2. Write the following in scientific notation.

- a) 0,511 MV
- b) 10 cℓ
- c) 0,5 μm
- d) 250 nm
- e) 0,00035 hg

Solution:

- a) $0,511 \text{ MV} = 0,511 \times 10^6 \text{ V} = 5,11 \times 10^5 \text{ V}$
- b) $10 \text{ cℓ} = 10 \times 10^{-2} \text{ ℓ} = 1,0 \times 10^{-1} \text{ ℓ}$
- c) $0,5 \text{ μm} = 0,5 \times 10^{-6} \text{ m} = 5 \times 10^{-7} \text{ m}$
- d) $250 \text{ nm} = 250 \times 10^{-9} \text{ m} = 2,50 \times 10^{-7} \text{ m}$
- e) $0,00035 \text{ hg} = 0,00035 \times 10^2 \text{ g} = 3,5 \times 10^{-2} \text{ g}$

3. Write the following using standard prefixes.

- a) $1,602 \times 10^{-15} \text{ C}$
- b) $1,992 \times 10^6 \text{ J}$
- c) $5,98 \times 10^4 \text{ N}$

- d) $25 \times 10^{-4} \text{ A}$
- e) $0,0075 \times 10^6 \text{ m}$

Solution:

- a) $1,602 \times 10^{-19} = 0,1602 \times 10^{-18} \text{ C} = 0,1602 \text{ aC}$
- b) $1,992 \times 10^6 \text{ J} = 1,992 \text{ MJ}$
- c) $5,98 \times 10^4 \text{ N} = 59,8 \times 10^3 \text{ N} = 59,8 \text{ kN}$
- d) $25 \times 10^{-4} \text{ A} = 2,5 \times 10^{-3} \text{ A} = 2,5 \text{ mA}$
- e) $0,0075 \times 10^6 \text{ m} = 7,5 \times 10^3 \text{ m} = 7,5 \text{ km}$

Exercise 1-2:

1. Write the following quantities in scientific notation:

- a) 10 130 Pa to 2 decimal places
- b) $978,15 \text{ m} \cdot \text{s}^{-1}$ to one decimal place
- c) 0,000001256 A to 3 decimal places

Solution:

- a) $1,01 \times 10^4 \text{ Pa}$
- b) $9,8 \times 10^2 \text{ m} \cdot \text{s}^{-1}$
- c) $1,256 \times 10^{-6} \text{ A}$

2. For each of the following symbols, write out the unit in full and write what power of 10 its prefix represents:

- a) μg
- b) mg
- c) kg
- d) Mg

Solution:

- a) microgram and -6
- b) milligram and -3
- c) kilogram and 3
- d) megagram and 6

3. Write each of the following in scientific notation, correct to 2 decimal places:

- a) 0,00000123 N

- b) 417 000 000 kg
- c) 246800 A
- d) 0,00088 mm

Solution:

- a) $1,23 \times 10^{-6}$ N
- b) $4,17 \times 10^8$ kg
- c) $2,47 \times 10^5$ A
- d) $8,80 \times 10^{-4}$ mm

4. For each of the following, write the measurement using the correct symbol for the prefix and the base unit:

- a) 1,01 microseconds
- b) 1 000 milligrams
- c) 7,2 megameters
- d) 11 nanolitre

Solution:

- a) $1,01 \mu\text{s}$
- b) 1000 mg
- c) 7,2 Mm
- d) 11 nℓ

5. The Concorde is a type of aeroplane that flies very fast. The top speed of the Concorde is $844 \text{ km} \cdot \text{hr}^{-1}$. Convert the Concorde's top speed to $\text{m} \cdot \text{s}^{-1}$.

Solution:

To convert from $\text{km} \cdot \text{hr}^{-1}$ to $\text{m} \cdot \text{s}^{-1}$ we must divide by 3,6.

$$844 \text{ km} \cdot \text{hr}^{-1} = (844 \div 3,6) \text{ m} \cdot \text{s}^{-1} = 234,44 \text{ m} \cdot \text{s}^{-1}$$

6. The boiling point of water is 100°C . What is the boiling point of water in kelvin?

Solution:

To convert from Celcius to Kelvin we add 273: $100^\circ\text{C} = (100 + 273)\text{K} = 373 \text{ K}$

Chapter 2. Classification of matter

Exercise 2-1:

Complete the following table:

Substance	Non-mixture or mixture	Heterogeneous mixture	Homogeneous mixture
tap water			
brass (an alloy of copper and zinc)			
concrete			
aluminium foil (tinfoil)			
Coca Cola			
soapy water			
black tea			
sugar water			
baby milk formula			

Solution:

Substance	Non-mixture or mixture	Heterogeneous mixture	Homogeneous mixture
tap water	mixture	No	Yes
brass (an alloy of zinc and copper)	mixture	No	Yes
concrete	mixture	No	Yes
aluminium foil (tinfoil)	non-mixture	N/A	N/A
Coca Cola	mixture	Yes	No
soapy water	mixture	Yes	No
black tea	mixture	No	Yes
sugar water	mixture	No	Yes
baby milk formula	mixture	No	Yes

Exercise 2-2:

1. In the following table, tick whether each of the substances listed is a mixture or a pure substance. If it is a mixture, also say whether it is a homogeneous or heterogeneous mixture.

Substance	Mixture or pure	Homogeneous or heterogeneous mixture
Fizzy cold drink		
Steel		
Oxygen		
Iron filings		
Smoke		
Limestone ($CaCO_3$)		

Solution:

Substance	Mixture or pure	Homogeneous or heterogeneous mixture
Fizzy cold drink	Mixture	Heterogeneous
Steel	Mixture	Homogeneous
Oxygen	Pure	N/A
Iron filings	Pure	N/A
Smoke	Mixture	Heterogeneous
Limestone ($CaCO_3$)	Mixture	Homogeneous

2. In each of the following cases, say whether the substance is an element, a mixture or a compound.

- Cu
- Iron and Sulphur
- Al
- H_2SO_4
- SO_3

Solution:

- a) Element
- b) Mixture
- c) Element
- d) Compound
- e) Compound

Exercise 2-3:

1. The formula for calcium carbonate is CaCO_3

- a) Is calcium carbonate a mixture or a compound? Give a reason for your answer.
- b) What is the ratio of $\text{Ca}:\text{C}:\text{O}$ in the formula?

Solution:

- a) Compound. It is a chemical combination of more than one element
- b) 1:1:3

2. Give the name of each of the following substances

- a) KBr
- b) HCl
- c) KMnO_4
- d) NO_2
- e) NH_4OH
- f) Na_2SO_4
- g) $\text{Fe}(\text{NO}_3)_3$
- h) PbSO_3
- i) $\text{Cu}(\text{HCO}_3)_2$

Solution:

- a) Potassium bromide
- b) Hydrogen chloride or Hydrochloric acid
- c) Potassium permanganate
- d) Nitrogen dioxide
- e) Ammonium hydroxide
- f) Sodium sulphate
- g) Iron (III) nitrate
- h) Lead (II) sulphite
- i) Copper (II) hydrogen carbonate

3. Give the chemical formula for each of the following compounds

- a) Potassium nitrate
- b) Sodium oxide
- c) Barium sulphate
- d) Aluminium chloride
- e) Magnesium phosphate
- f) Tin(II) bromide
- g) Manganese(II) phosphide

Solution:

- a) KNO_3
- b) Na_2O
- c) BaSO_4
- d) AlCl_3
- e) $\text{Mg}_3(\text{PO}_4)_2$
- f) SnBr_2
- g) Mn_3P_2

End of chapter exercises:

1. Which of the following can be classified as a mixture:

- a) sugar
- b) table salt
- c) air
- d) iron

Solution:

- c) air

2. An element can be defined as:

- a) A substance with constant composition
- b) A substance that contains two or more substances, in definite proportion by weight
- c) A uniform substance
- d) A substance that cannot be separated into two or more substances by ordinary chemical (or physical) means

Solution:

- c) A substance that cannot be separated into two or more substances by ordinary

chemical (or physical) means

3. Classify each of the following substances as an element, a compound, a solution (homogeneous mixture), or a heterogeneous mixture: salt, pure water, soil, salt water, pure air, carbon dioxide, gold and bronze

Solution:

Salt: Compound

Pure Water: Compound

Soil: Heterogeneous Mixture

Salt Water: Solution

Pure Air: Solution

Carbon Dioxide: Compound

Gold: Element

Bronze: Solution

4. Look at the table below. In the first column (A) is a list of substances. In the second column (B) is a description of the group that each of these substances belongs in. Match up the substance in Column A with the description in Column B. Write only the letter and the corresponding number.

Column A	Column B
1. Iron	A. A compound containing 2 elements
2. H ₂ S	B. A heterogeneous mixture
3. Sugar solution	C. A metal alloy
4. Sand and stones	D. An element
5. steel	E. A homogeneous mixture

Solution

1) D

2) A

3) E

4) B

5) C

5. You are given a test tube that contains a mixture of iron filings and sulphur. You are asked to weight the amount of iron in the sample.

- a) Suggest one method that you could use to separate the iron filings from the sulphur.
- b) What property of metals allows you to do this?

Solution:

- a) Extract the iron filings using a magnet
- b) Magnetism

6. Given the following descriptions, write the chemical formula for each of the following substances:

- a) Silver metal
- b) A compound that contains only potassium and bromine
- c) A gas that contains the elements carbon and oxygen in a ratio of 1:2

Solution:

- a) Ag
- b) KBr
- c) CO₂

7. Give the names of each of the following compounds

- a) NaBr
- b) BaSO₄
- c) SO₂
- d) H₂SO₄

Solution:

- a) Sodium bromide
- b) Barium sulphate
- c) Sulphur dioxide
- d) Hydrogen sulphate (sulphuric acid)

8. Give the formula for each of the following compounds:

- a) Iron (II) sulphate
- b) Boron trifluoride
- c) Potassium permanganate
- d) Zinc chloride

Solution:

- a) FeSO₄

- b) BF_3
- c) KMnO_4
- d) ZnCl_2

9. For each of the following materials, say what properties of the material make it important in carrying out its particular function

- a) Tar on roads
- b) Iron burglar bars
- c) Plastic furniture
- d) Metal jewellery
- e) Clay for building
- f) Cotton clothing

Solution:

Some suggestions for answers are given. Learners could discuss these questions amongst themselves.

- a) High coefficients of friction
- b) Inelastic, durable
- c) Durable, easily cleaned
- d) Shiny, malleable
- e) Easily moulded while wet, strong and durable once dry
- f) Fibrous, allows skin to "breathe"

Chapter 3. States of matter and the kinetic molecular theory

End of chapter exercises:

1. Give one word or term for each of the following descriptions.

- The change in phase from a solid to a gas
- The change in phase from liquid to gas.

Solution:

- Sublimation
- Evaporation

2. Water has a boiling point of 100°C

- Define "boiling point"
- What change in phase takes place when a liquid reaches its boiling point

Solution:

- The temperature at which a liquid changes its phase to become a gas.
- Liquid to gas.

3. Describe a solid in terms of the kinetic molecular theory.

Solution:

A solid consists of atoms or molecules that have a low energy (vibrate around a fixed point). The particles are tightly packed together (there is very little space), there are strong attractive forces between the molecules. Solids have a fixed volume. Solids become liquids if their temperature is increased. In a few, rare cases solids become gases when their temperature is increased.

4. Refer to the table below which gives the melting and boiling points of a number of elements, and then answer the questions that follow.

Element	Melting point (°C)	Boiling point (°C)
Copper	1083	2567
Magnesium	650	1107
Oxygen	-218,4	-183
Carbon	3500	4827
Helium	-272	-268.6
Sulphur	112.8	444.6

- a) What state of matter (i.e. solid, liquid or gas) will each of these elements be in at room temperature?
- b) Which of these elements has the strongest forces between its atoms? Give a reason for your answer.
- c) Which of these elements has the weakest forces between its atoms? Give a reason for your answer.

Solution:

- a) Copper, magnesium, carbon and sulphur will all be solids. Oxygen and helium will be in the gas phase.
- b) Carbon. It has the highest melting and boiling points. Since melting and boiling points are related to the intermolecular forces, the higher the melting and boiling points are the stronger the forces are.
- c) Helium. It has the lowest melting and boiling points. Since melting and boiling points are related to the intermolecular forces the lower the melting and boiling points are the weaker the forces are.

5. Complete the following submicroscopic diagrams to show what magnesium will look like in the solid, liquid and gas phase.

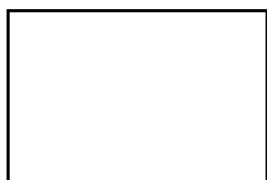

solid

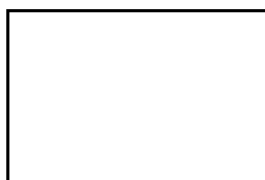

liquid



gas

Solution:

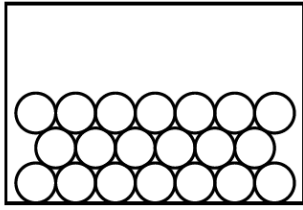

solid

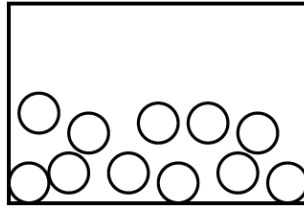

liquid

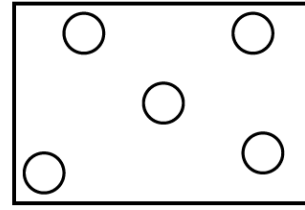

gas

Chapter 4. The atom

Exercise 4-1:

Match the information in column A, with the key discoverer in column B.

Column A	Column B
1. Discovery of electrons and the plum pudding model	A. Niels Bohr
2. Arrangement of electrons	B. Marie and Pierre Curie
3. Atoms as the smallest building block of matter	C. Ancient Greeks and Dalton
4. Discovery of the nucleus	D. JJ Thomson
5. Discovery of radiation	E. Rutherford

Solution:

1. JJ Thomson
2. Niels Bohr
3. Ancient Greeks and Dalton
4. Rutherford
5. Marie and Pierre Curie

Exercise 4-2:

1. Explain the meaning of each of the following terms :

- a) nucleus
- b) electron
- c) atomic mass

Solution:

a) Key points: protons, neutrons, nucleons, centre of atom. Learners should have all these words in their definition.

A sample definition would be: The nucleus is the centre of the atom. It consists of neutrons and protons. Together, these neutrons and protons are called nucleons. The nucleus is the most dense part of the atom.

b) Key points: light particles, negatively charged, surround nucleus. Learners should include all these words in their definition.

A sample definition is: The electron is a very light particle. Electrons are found around the nucleus of an atom. Electrons are negatively charged particles.

c) The atomic mass of an atom is the number of protons in the atom.

2. Complete the following table: (Note: You will see that the atomic masses on the periodic table are not whole numbers. For now you can round off to the nearest whole number)

Element	Atomic mass units	Atomic number	Number of protons	Number of electrons	Number of neutrons
Mg	24	12			
O			8		
		17			
Ni				28	
	40				20
Zn					
					0
C	12			6	
Al ³⁺		13			
O ²⁻				18	

Solution:

Element	Atomic mass	Atomic number	Number of protons	Number of electrons	Number of neutrons
Mg	24	12	12	12	12
O	16	8	8	8	8
Cl	35	17	17	17	18
Ni	59	28	28	28	31
Ca	40	20	20	20	20

Zn	65	30	30	30	35
H	1	1	1	1	0
C	12	6	6	6	6
Al^{3+}	27,0	13	13	13	14
O^{2-}	16,0	8	8	8	8

3. Use standard notation to present the following elements:

- a) potassium
- b) copper
- c) chlorine

Solution:

- a) ${}^{40}_{19}K$
- b) ${}^{64}_{29}Cu$
- c) ${}^{35}_{17}Cl$

4. For the element ${}^{35}_{17}Cl$ give the number of:

- a) protons
- b) neutrons
- c) electrons
- ...in the atom.

Solution:

- a) 17
- b) 18
- c) 17

5. Which of the following atoms has 7 electrons?

- a) 5_2He
- b) ${}^{13}_6C$
- c) 7_3Li
- d) ${}^{15}_7N$

Solution:

D is correct. There are 7 protons (the subscript number) and since the atom is neutral there will also be 7 electrons.

6. In each of the following cases, give the number or the element symbol represented by X.

- a) ${}_{18}^{40}\text{X}$
 b) ${}_{20}^{\text{X}}\text{Ca}$
 c) ${}_{\text{X}}^{31}\text{P}$

Solution:

- a) This element has 18 protons and 40 nucleons. So the element must be Argon, with symbol Ar since it has 18 protons.
 b) Ca has 20 protons and 40 nucleons, so X is 40.
 c) Phosphorus has 31 nucleons and 15 protons. So X is 15.

7. Complete the following table and then answer the questions that follow.

	A	Z	N
${}_{92}^{235}\text{U}$			
${}_{92}^{238}\text{U}$			

In these two different forms of Uranium:

- a) What is the same?
 b) What is different?

Solution:

	A	Z	N
${}_{92}^{235}\text{U}$	235	92	143
${}_{92}^{238}\text{U}$	238	92	146

- a) Z is the same. The number of protons does not change between these two forms
 b) N and A are different. The number of neutrons changes which affects N and A.

Exercise 4-3:

1. Atom A has 5 protons and 5 neutrons. Atom B has 6 protons and 5 neutrons. These atoms are:

- a) allotropes
- b) isotopes
- c) isomers
- d) atoms of different elements

Solution:

- d) atoms of different elements

2. For the sulphur isotopes, i) ${}_{16}^{32}\text{S}$ and ii) ${}_{16}^{34}\text{S}$ give the number of:

- a) protons
- b) nucleons
- c) electrons
- d) neutrons

Solution:

- a) The number of protons is the subscript number (Z) so: i) 16 ii) 16
- b) The number of nucleons is the superscript number (A) so: i) 32 ii) 34
- c) The number of electrons in a neutral atom is the same as the number of protons and so for both i) and ii) the number of electrons is 16
- d) The number of neutrons (N) is the number of nucleons - the number of protons or: $A - Z = N$.

For i) $A - Z = 32 - 16 = 16$ and for ii) $A - Z = 34 - 16 = 18$.

3. Which of the following are isotopes of ${}_{17}^{35}\text{Cl}$?

- a) ${}_{35}^{17}\text{Cl}$
- b) ${}_{17}^{35}\text{Cl}$
- c) ${}_{17}^{37}\text{Cl}$

Solution:

c) is correct. Answer a) is not written in the correct form and answer b) is the same element.

4. Which of the following are isotopes of U-235? (E represents an element symbol)

- a) ${}_{92}^{238}\text{E}$
- b) ${}_{90}^{238}\text{E}$
- c) ${}_{92}^{235}\text{E}$

Solution:

a) is correct. b) is a different element and c) is the standard notation for U-235.

5. Complete the table below:

Isotope	Z	A	Protons	Neutrons	Electrons
Carbon-12					
Carbon-14					
Iron-54					
Iron-56					
Iron-57					

Solution:

Isotope	Z	A	Protons	Neutrons	Electrons
Carbon-12	6	12	6	6	6
Carbon-14	6	14	6	8	6
Iron-54	26	54	26	28	26
Iron-56	26	56	26	30	26
Iron-57	26	57	26	31	26

6. If a sample contains 19,9% boron-10 and 80,1% boron-11, calculate the relative atomic mass of an atom of boron in that sample.

Solution:

$\frac{19,9}{100} \times 10 = 1,99 \text{ u}$ is the contribution to the relative atomic mass from boron-10.

And the contribution from boron-11 is: $\frac{80,1}{100} \times 11 = 8,811 \text{ u}$.

Now we add these two together and get the relative atomic mass:

$$1,99 \text{ u} + 8,811 \text{ u} = 10,8 \text{ u}$$

7. If a sample contains 79% Mg-24, 10% Mg-25 and 11% Mg-26, calculate the relative atomic mass of an atom of magnesium in that sample.

Solution:

$\frac{79}{100} \times 24 = 18,96 \text{ u}$ is the contribution to the relative atomic masses from Mg-24.

The contribution from Mg-25 is: $\frac{10}{100} \times 25 = 2,5 \text{ u}$.

And the contribution from Mg-26 is: $\frac{11}{100} \times 26 = 2,86 \text{ u}$.

Now we add these up and get the relative atomic mass: $18,96 \text{ u} + 2,5 \text{ u} + 2,86 \text{ u} = 24,3 \text{ u}$

8. For the element (${}^{234}_{92}\text{U}$ uranium), use standard notation to describe:

- the isotope with 2 fewer neutrons
- the isotope with 4 more neutrons

Solution:

a. ${}^{232}_{92}\text{U}$

b. ${}^{238}_{92}\text{U}$

9. Which of the following are isotopes of ${}^{40}_{20}\text{Ca}$?

a. ${}^{40}_{19}\text{K}$

b. ${}^{42}_{20}\text{Ca}$

c. ${}^{40}_{18}\text{Ar}$

Solution:

b) is correct. a) and c) are different elements and so cannot be isotopes of calcium.

10. For the sulphur isotope ${}^{33}_{16}\text{S}$, give the number of:

- protons
- nucleons
- electrons
- neutrons

Solution:

- a. 16
- b. 33
- c. 16
- d. 17

Exercise 4-4:

Complete the following table:

Element or ion	Electron configuration	Core electrons	Valence electrons
Potassium (K)			
Helium (He)			
Oxygen ion (O^{2-})			
Magnesium ion (Mg^{2+})			

Solution:

Element or ion	Electron configuration	Core electrons	Valence electrons
Potassium (K)	$[Ar]4s^1$	18	1
Helium (He)	$1s^2$	2	2
Oxygen ion (O^{2-})	$1s^2 2s^2 2p^6$	2	8
Magnesium ion (Mg^{2+})	$1s^2 2s^2 2p^6$	2	8

Exercise 4-5:

1. Draw Aufbau diagrams to show the electron configuration of each of the following elements:

- a) Magnesium
- b) Potassium
- c) Sulphur
- d) Neon
- e) Nitrogen

2. Use the Aufbau diagrams that you have drawn to help you complete the following table:

Element	No. of energy levels	No. of electrons	Electron configuration (standard notation)
Mg			
K			
S			
Ne			
N			
Ca^{2+}			
Cl^-			

3. Rank the elements above in order of increasing reactivity. Give reasons for your answers.

Solutions:

1. Using the rules about drawing Aufbau diagrams we get the following:

a) Magnesium has 12 electrons. So we start with energy level 1 and put 2 electrons in it. Then we move to energy level two which has the 2s and the 2p orbitals. This level can hold 8 electrons. Adding up the total electrons used so far gives 10 electrons. So we must place two more electrons and these go into the third level.

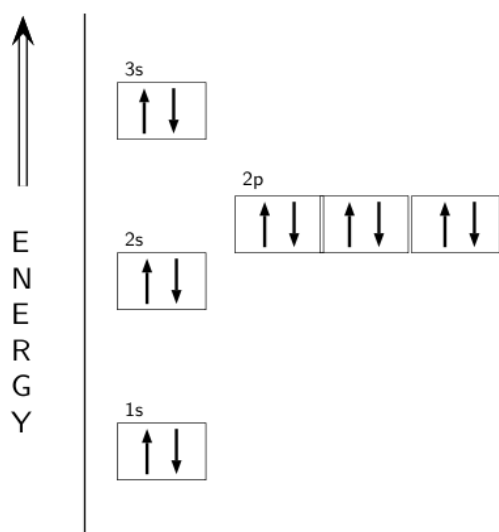

b) Potassium has 19 electrons. So we get:

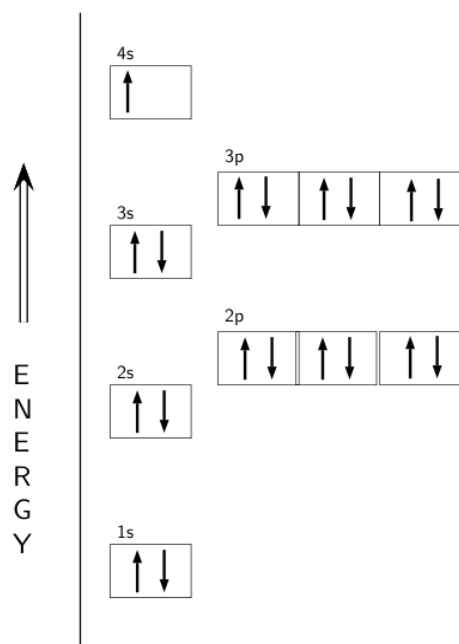

c) Sulphur has 16 electrons so we get:

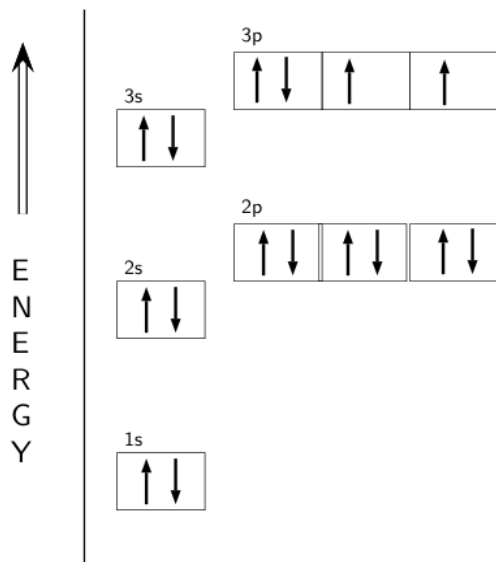

d) Neon has 10 electrons so we get:

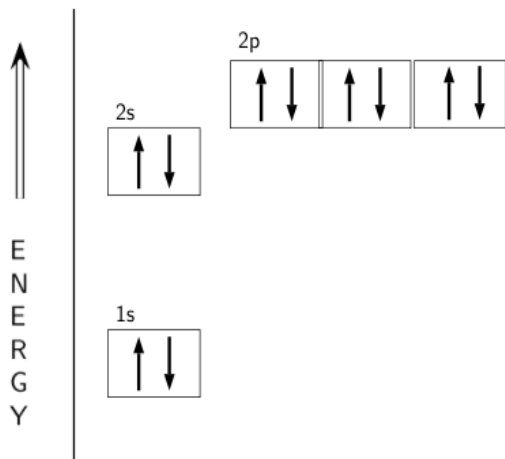

e) Nitrogen has 7 electrons so we get:

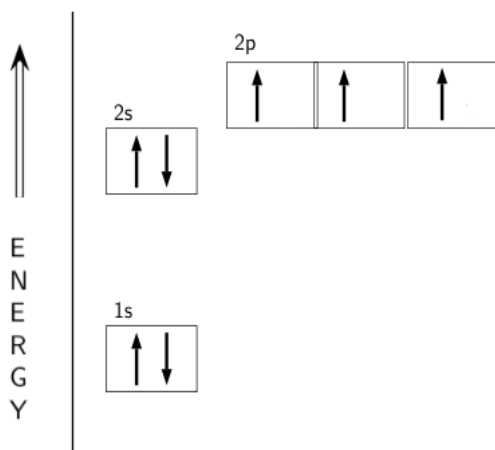

2. The energy levels are given by the numeral above the boxes, so 1, 2, 3 etc. The number of core electrons is all the electrons that are not in the outermost energy level. The number of valence electrons is the number of electrons in the outermost energy level. And the electron configuration is simply listing the energy levels together with the orbitals and the number of electrons in each orbital. So for magnesium the number of energy levels is 3, the number of core electrons is 10, the number of valence electrons is 2 and the electron configuration is: $1s^2 2s^2 2p^6 3s^2$.

Filling in the table gives:

Element	No. of energy levels	No. of electrons	Electron configuration (standard notation)
Mg	3	10	$1s^2 2s^2 2p^6 3s^2$
K	4	18	$1s^2 2s^2 2p^6 3s^2 3p^6 4s^1$
S	3	10	$1s^2 2s^2 2p^6 3s^2 3p^4$
Ne	2	2	$1s^2 2s^2 2p^6$
N	2	2	$1s^2 2s^2 2p^3$
Ca^{2+}	4	18	$1s^2 2s^2 2p^6$
Cl^-	3	18	$1s^2 2s^2 2p^6 3s^2 3p^6$

3. Order of reactivity is complex and difficult. But could possibly go like: $Ne < Mg < K < S < N$.
Mg, K and S may be all about the same in reactivity.

End of chapter exercises:

1. Write down only the word/term for each of the following descriptions.

- The sum of the number of protons and neutrons in an atom
- The defined space around an atom's nucleus, where an electron is most likely to be found

Solution:

- atomic mass number
- electron orbital

2. For each of the following, say whether the statement is true or false. If it is false, re-write the statement correctly.

- ${}_{10}^{20}\text{Ne}$ and ${}_{10}^{22}\text{Ne}$ each have 10 protons, 12 electrons and 12 neutrons.
- The atomic mass of any atom of a particular element is always the same.
- It is safer to use helium gas rather than hydrogen gas in balloons.
- Group 1 elements readily form negative ions.

Solution:

- False. They both have 10 protons, 12 electrons but ${}_{10}^{20}\text{Ne}$ has 10 protons and ${}_{10}^{22}\text{Ne}$ has 12 protons.
- True.

- c) True.
- d) False. Group 1 elements readily form positive ions.

3. The three basic components of an atom are:

- a) protons, neutrons, and ions
- b) protons, neutrinos, and ions
- c) protium, deuterium, and tritium
- d) protons, neutrons, and electrons

Solution:

- d) protons, neutrons, and electrons

4. The charge of an atom is:

- a) Positive
- b) Negative
- c) Neutral
- d) None of the above

Solution:

- c) neutral

5. If Rutherford had used neutrons instead of alpha particles in his scattering experiment, the neutrons would:

- a) have deflected more often
- b) have been attracted to the nucleus easily
- c) have given the same results
- d) not deflect because they have no charge

Solution:

- d) not deflect because they have no charge

6. Consider the isotope ${}_{92}^{234}\text{U}$. Which of the following statements is true?

- a) The element is an isotope of ${}_{94}^{234}\text{Pu}$
- b) The element contains 234 neutrons
- c) The element has the same electron configuration as ${}_{92}^{238}\text{U}$
- d) The element has an atomic mass number of 92

Solution:

c) The element has the same electron configuration as ${}_{92}^{238}\text{U}$

7. The electron configuration of an atom of chlorine can be represented using the following notation:

- a) $1s^2 2s^8 3s^7$
- b) $1s^2 2s^2 2p^6 3s^2 3p^5$
- c) $1s^2 2s^2 2p^6 3s^2 3p^6$
- d) $1s^2 2s^2 2p^5$

Solution:

b) $1s^2 2s^2 2p^6 3s^2 3p^5$

8. Give the standard notation for the following elements:

- a) beryllium
- b) carbon-12
- c) titanium-48
- d) fluorine

Solution:

a) Beryllium has 4 protons and 5 neutrons. So the number of nucleons is 9. The standard notation is: ${}^9_4\text{Be}$

b) Carbon has 6 protons and 6 neutrons. So the number of nucleons is 12. The standard notation is: ${}^{12}_6\text{C}$

c) Titanium has 22 protons and 26 neutrons. So the number of nucleons is 48. The standard notation is: ${}^{48}_{22}\text{Ti}$

d) Fluorine has 9 protons and 10 neutrons. So the number of nucleons is 19. The standard notation is: ${}^{19}_9\text{F}$

9. Give the electron configurations and Aufbau diagrams for the following elements:

- a. aluminium
- b. phosphorus
- c. carbon
- d. oxygen ion
- e. calcium ion

Solution:

a) Aluminium has 13 electrons. So the electron configuration is: $1s^2 2s^2 2p^6 3s^2 3p^1$

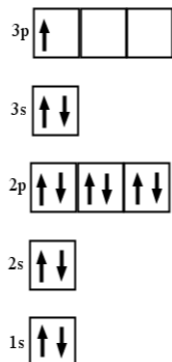

b) Phosphorus has 15 electrons. So the electron configuration is: $1s^2 2s^2 2p^6 3s^2 3p^3$

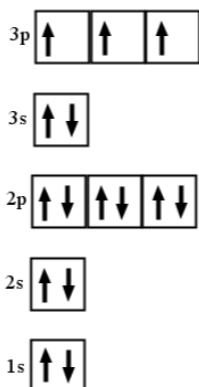

c) Carbon has 6 electrons. So the electron configuration is: $1s^2 2s^2 2p^2$

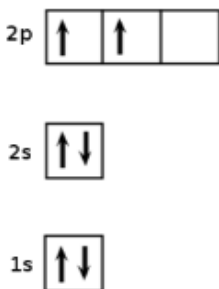

d) Oxygen has 8 electrons. The oxygen ion has gained two electrons and so the total number of electrons is 10. The electron configuration is: $1s^2 2s^2 2p^6$

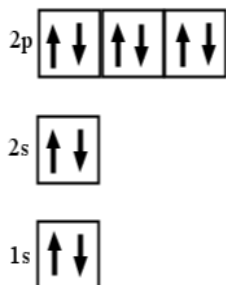

e) Calcium has 20 electrons. The calcium ion has lost two electrons and so the total number of electrons is 18. The electron configuration is: $1s^2 2s^2 2p^6 3s^2 3p^6$

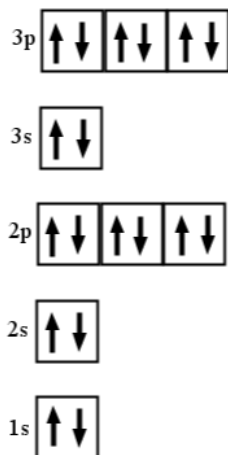

10. For each of the following elements give the number of protons, neutrons and electrons in the element:

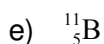
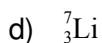
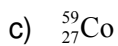
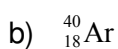
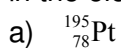

Solution:

a) $Z = 78$ and $A = 195$. So the number of protons is 78 and the number of neutrons is $N = A - Z = 195 - 78 = 117$. Since the element is neutral the number of electrons is also 78.

b) $Z = 18$ and $A = 40$. So the number of protons is 18 and the number of neutrons is $N = A - Z = 40 - 18 = 22$. Since the element is neutral the number of electrons is also 18.

c) $Z = 27$ and $A = 59$. So the number of protons is 27 and the number of neutrons is $N = A - Z = 59 - 27 = 32$. Since the element is neutral the number of electrons is also 27.

d) $Z = 3$ and $A = 7$. So the number of protons is 3 and the number of neutrons is

$N = A - Z = 7 - 3 = 4$. Since the element is neutral the number of electrons is also 3.

e) $Z = 5$ and $A = 11$. So the number of protons is 5 and the number of neutrons is
 $N = A - Z = 11 - 5 = 6$. Since the element is neutral the number of electrons is also 5.

11. For each of the following elements give the element or number represented by 'x':

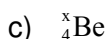
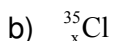
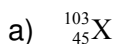

Solution:

a) This element has 45 protons and atomic mass number of 103. Looking on the periodic table we find that the element with 45 protons and atomic mass number of 103 is Rhodium (Rh).

b) We are given that chlorine has 35 protons and neutrons. We need to find out how many protons it has. From the periodic table we find that $x = 17$

c) We are given that beryllium has 4 protons. We look at the atomic mass given on the periodic table and see that it is 9. So $x = 5$.

12. Which of the following are isotopes of ${}_{12}^{24}\text{Mg}$?

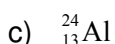
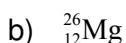
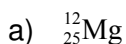

Solution:

b) is the only correct answer. An isotope has the same number of protons, but a different number of neutrons. c) is a different element and a) has 25 protons, but -13 neutrons, which is not chemically possible.

13. If a sample contains 69% of copper-63 and 31% of copper-65, calculate the relative atomic mass of an atom in that sample.

Solution:

The contribution from copper-63 is: $\frac{69}{100} \times 63 = 43,47$

The contribution from copper-45 is: $\frac{31}{100} \times 65 = 20,15$

Now we add the two values to get the relative atomic mass:

$$43,47 + 20,15 = 63,63 \text{ u}$$

This value is slightly higher than the one on the periodic table which is mainly due to rounding errors.

14. Complete the following table:

Element or ion	Electron configuration	Core electrons	Valence electrons
Boron (B)			
Calcium (Ca)			
Silicon (Si)			
Lithium ion (Li^+)			
Neon (Ne)			

Solution

Element or ion	Electron configuration	Core electrons	Valence electrons
Boron (B)	$[\text{He}] 2s^2 2p^1$	2	3
Calcium (Ca)	$[\text{Ar}] 4s^2$	18	2
Silicon (Si)	$[\text{Ne}] 3s^2 3p^2$	10	5
Lithium ion (Li^+)	$1s^2$	0	2
Neon (Ne)	$1s^2 2s^2 2p^6$	2	8

Chapter 5. The periodic table

Exercise 5-1:

1. Use Table 5.1 and Figure 5.2 to help you produce a similar table for the elements in period 2.

Solution:

Element	${}^7_3\text{Li}$	${}^9_4\text{Be}$	${}^{11}_5\text{B}$	${}^{12}_6\text{C}$	${}^{14}_7\text{N}$	${}^{16}_8\text{O}$	${}^{19}_9\text{F}$	${}^{20}_{10}\text{Ne}$
Chlorides	LiCl	BeCl ₂	BCl ₃	CCl ₄	NCl ₃	no compounds, but oxygen does combine with chlorine in compounds called chlorine oxides	no compounds	no compounds
Oxides	Li ₂ O	BeO	B ₂ O ₃	CO ₂ or CO	NO ₂ or NO	no compounds, oxygen combines with itself to form O ₂	no oxides, but fluorine does combine with oxygen in compounds called oxygen fluorides	no compounds
Electron configuration	[He]2s ¹	[He]2s ²	[He]2s ² 2p ¹	[He]2s ² 2p ²	[He]2s ² 2p ³	[He]2s ² 2p ⁴	[He]2s ² 2p ⁵	[He]2s ² 2p ⁶
Atomic radius	Decreases across the period							
First ionisation energy	Increases across the period							
Electronegativity	Increases across the period							
Melting and boiling points	Increases to carbon and then decreases to argon							
Electrical conductivity	Increases to boron and then decreases. Boron is a semi-conductor, while carbon, oxygen, nitrogen, fluorine and argon are non-metals. Lithium and beryllium are metals.							

2. Refer to the data table below which gives the ionisation energy (in $\text{kJ}\cdot\text{mol}^{-1}$) and atomic number (Z) for a number of elements in the periodic table:

Z	Name of element	Ionisation energy	Z	Name of element	Ionisation energy
1		1310	10		2072
2		2360	11		494
3		517	12		734
4		895	13		575
5		797	14		783
6		1087	15		1051
7		1397	16		994
8		1307	17		1250
9		1673	18		1540

- Fill in the names of the elements.
- Draw a line graph to show the relationship between atomic number (on the x-axis) and ionisation energy (y-axis).
- Describe any trends that you observe.
- Explain why:
 - the ionisation energy for $Z = 2$ is higher than for $Z = 1$
 - the ionisation energy for $Z = 3$ is lower than for $Z = 2$
 - the ionisation energy increases between $Z = 5$ and $Z = 7$

Solution:

a.

Z	Name of element	Ionisation energy	Z	Name of element	Ionisation energy
1	Hydrogen	1310	10	Neon	2072
2	Helium	2360	11	Sodium	494
3	Lithium	517	12	Magnesium	734
4	Beryllium	895	13	Aluminium	575
5	Boron	797	14	Silicon	783
6	Carbon	1087	15	Phosphorus	1051
7	Nitrogen	1397	16	Sulphur	994
8	Oxygen	1307	17	Chlorine	1250
9	Fluorine	1673	18	Argon	1540

b.

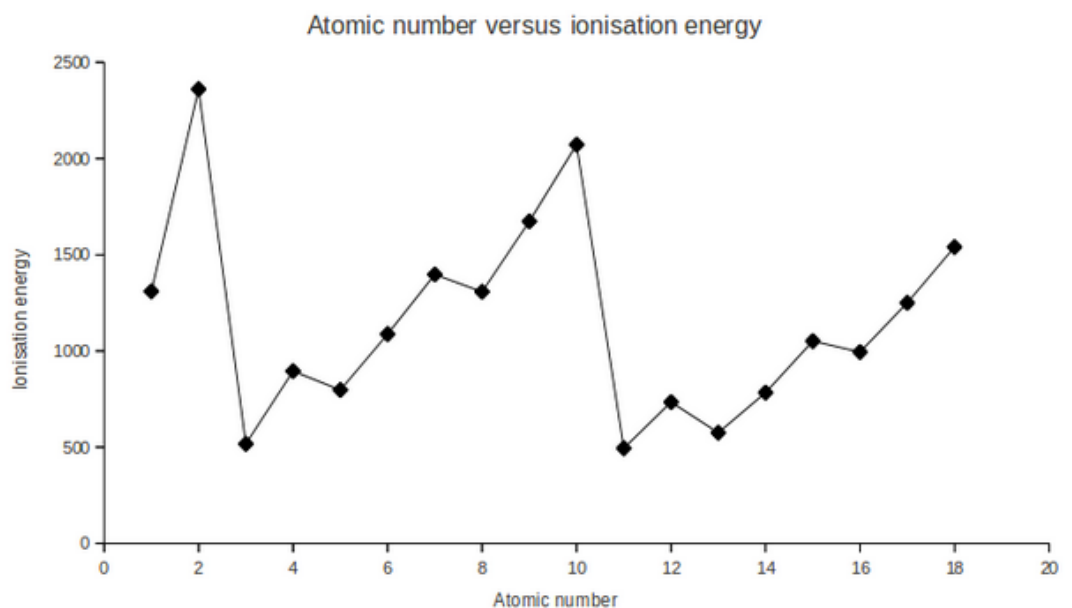

c. The ionisation energy increases across the periods.

d i) Since the atom with $Z=2$ has a full outer shell it is harder to remove electrons and so the ionisation energy will be higher. $Z=1$ has only 1 electron in its outermost shell.

ii) The atom with $Z=3$ has 1 electron in its outermost shell. The atom with $Z=2$ has a full outer shell. This means that the ionisation energy for $Z=3$ will be lower than for $Z=2$ since it will be easier to remove the electron from the atom with $Z=3$.

iii) As you increase the atomic number the number of electrons in the outermost shell increases. As the number of electrons in the outermost shell increase the energy needed to remove one of those electrons also increases. In other words the atom holds onto its electrons more tightly and the ionisation energy increases.

Exercise 5-2:

1. Use Table 5.2 and Figure 5.4 to help you produce similar tables for group 2 and group 17.

Solution

Element	Be	Mg	Ca	Sr	Ba
Electron structure	$[He]2s^2$	$[Ne]3s^2$	$[Ar]4s^2$	$[Kr]5s^2$	$[Xe]6s^2$
Chlorides	$BeCl_2$	$MgCl_2$	$CaCl_2$	$SrCl_2$	$BaCl_2$
	All form chlorides in the ratio 1:2				
Oxides	BeO	MgO	CaO	SrO	BaO
	All form oxides in the ratio 1:1				
Atomic radius	Increases down the group				
First ionisation energy	Decreases down the group				
Electronegativity	Decreases down the group				
Boiling and melting point	Decreases down the group				
Density	Increases down the group				

Element	F	Cl	Br	I	At
Electron configuration	$[He]2s^2 2p^5$	$[Ne]3s^2 3p^5$	$[Ar]4s^2 4p^5$	$[Kr]5s^2 5p^5$	$[Xe]6s^2 6p^5$
Atomic radius	Increases down the group				
First ionisation energy	Decreases down the group				
Electronegativity	Decreases down the group				
Boiling and melting point	Increases down the group				
Density	Increases down the group				

Note that the melting and boiling points of the halogens DO NOT follow the trend given.

2. The following two elements are given. Compare these elements in terms of the following properties. Explain the differences in each case. ${}^{24}_{12}\text{Mg}$ and ${}^{40}_{20}\text{Ca}$

- Size of the atom (atomic radius)
- Electronegativity
- First ionisation energy
- Boiling point

Solution:

a) Calcium has a larger atomic radius than magnesium. Calcium has more electrons than

magnesium and is filling an extra energy level. This increases the atomic radius.

b) Magnesium has a higher electronegativity than calcium. As you move down a group the valence electrons are further away from the nucleus and so experience less attraction from the nucleus. This decreases the elements pull on the electrons (electronegativity).

c) Magnesium has a higher first ionisation energy than calcium. As you move down a group, the outermost electrons are further away from the nucleus and are not held as tightly. This makes the ionisation energy higher for atoms at the top of a group.

d) Magnesium has a higher boiling point than calcium. Magnesium has stronger forces holding its atoms together and so more energy is needed to make magnesium boil.

3. Study the following graph and explain the trend in electronegativity of the group 2 elements.

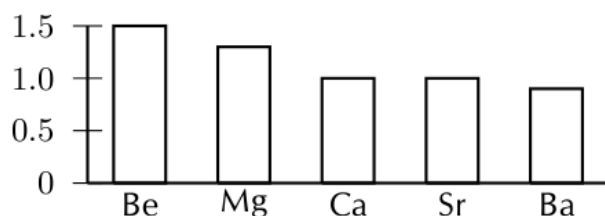

Solution:

As you move down a group the electronegativity decreases. This is due to the valence electrons being further away from the nucleus and so experience less attractive forces. As the electrons are not held as tightly the element's electronegativity decreases.

4. Refer to the elements listed below:

Lithium (Li);
Chlorine (Cl);
Magnesium (Mg);
Neon (Ne);
Oxygen (O);
Calcium (Ca);
Carbon (C)

Which of the elements listed above:

- belongs to Group 1
- is a halogen
- is a noble gas
- is an alkali metal

- e) has an atomic number of 12
- f) has 4 neutrons in the nucleus of its atoms
- g) contains electrons in the 4th energy level
- h) has all its energy orbitals full
- i) will have chemical properties that are most similar

Solution:

- a) Lithium
- b) Chlorine
- c) Neon
- d) Lithium (Group 1 metals are known as alkali metals)
- e) Carbon
- f) Lithium
- g) Calcium
- h) Neon
- i) Magnesium and calcium would have similar chemical properties as they are in the same group of the periodic table.

End of chapter exercises:

1. For the following questions state whether they are true or false. If they are false, correct the statement.

- a) The group 1 elements are sometimes known as the alkali earth metals.
- b) The group 8 elements are known as the noble gases.
- c) Group 7 elements are very unreactive.
- d) The transition elements are found between groups 3 and 4.

Solution:

- a) False. The group 1 elements are sometimes known as the alkali metals.
- b) True.
- c) False. Group 7 elements are very reactive.
- d) False. The transition elements are found between groups 2 and 3.

2. Give one word or term for each of the following:

- a) The energy that is needed to remove one electron from an atom
- b) A horizontal row on the periodic table
- c) A very reactive group of elements that is missing just one electron from their outer shells.

Solution:

- a) First ionization energy
- b) Period
- c) Halogens (group 17)

3. Given ${}_{35}^{80}\text{Br}$ and ${}_{17}^{35}\text{Cl}$. Compare these elements in terms of the following properties. Explain the differences in each case.

- a) Atomic radius
- b) Electronegativity
- c) First ionisation energy
- d) Boiling point

Solution:

- a) Bromine has a larger atomic radius than chlorine. Bromine has more electrons than chlorine and is filling an extra energy level. This increases the atomic radius.
- b) Chlorine has a higher electronegativity than bromine. As you move down a group the valence electrons are further away from the nucleus and so experience less attraction from the nucleus. This decreases the elements pull on the electrons (electronegativity).
- c) Chlorine has a higher first ionisation energy than bromine. As you move down a group, the outermost electrons are further away from the nucleus and are not held as tightly. This makes the ionisation energy higher for atoms at the top of a group.
- d) Chlorine has a higher boiling point than bromine. Chlorine has stronger forces holding its atoms together and so more energy is needed to make chlorine boil.

4. Given the following table

Element	Na	Mg	Al	Si	P	S	Cl	Ar
Atomic number	11	12	13	14	15	16	17	18
Density ($\text{g} \cdot \text{cm}^{-3}$)	0,97	1,74	2,70	2,33	1,82	2,08	3,17	1,78
Melting point ($^{\circ}\text{C}$)	370,9	923,0	933,5	1687	317,3	388,4	171,6	83,8
Boiling point ($^{\circ}\text{C}$)	1156	1363	2792	3538	550	717,8	239,1	87,3
Electronegativity	0.93	1.31	1.61	1.90	2.19	2.58	3.16	-

Draw graphs to show the patterns in the following physical properties:

- a. Density
- b. Boiling point
- c. Melting point
- d. Electronegativity

Solution

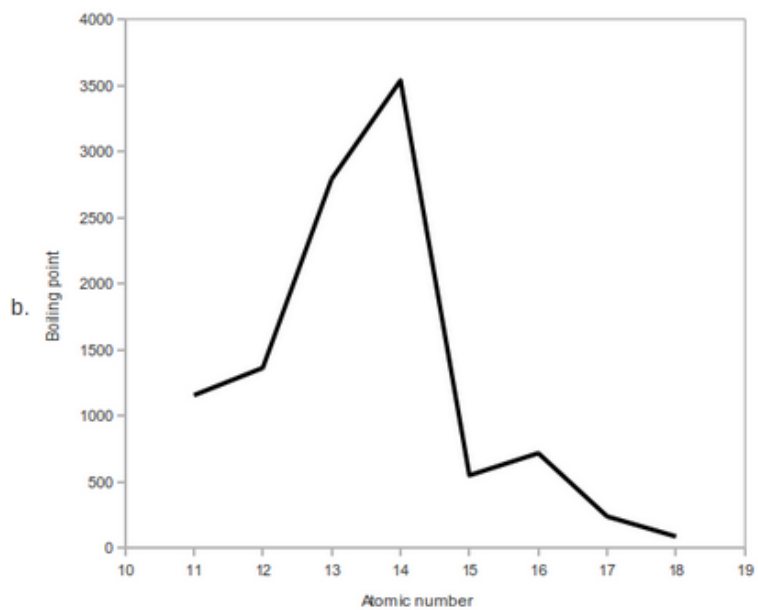
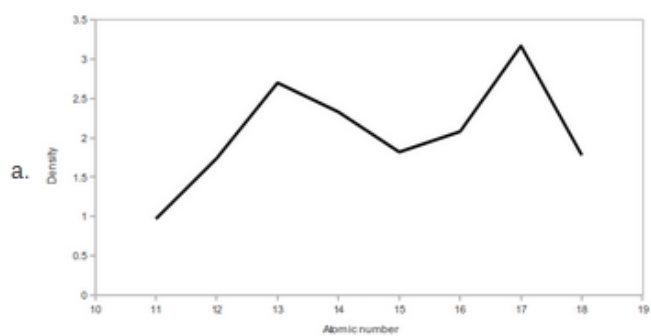

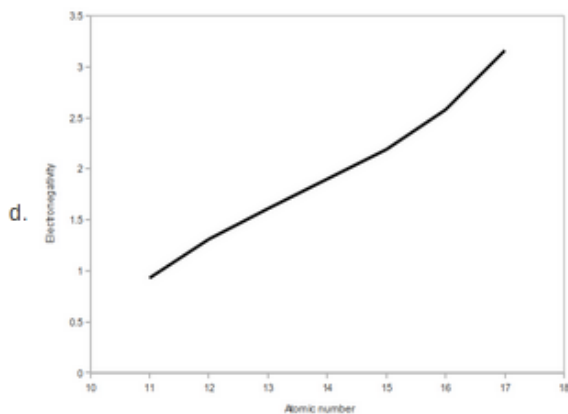
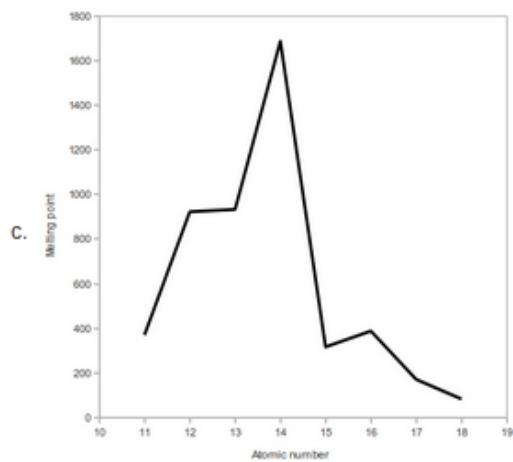

5. A graph showing the pattern in first ionisation energy for the elements in period 3 is shown below:

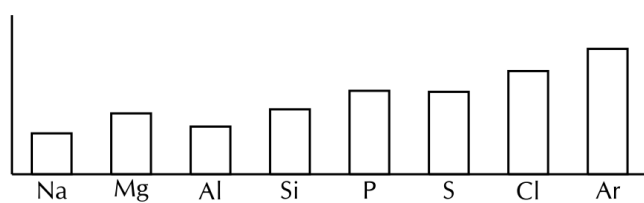

- Explain the pattern by referring to the electron configuration
- Predict the pattern in the first ionisation energy for the elements in period 2.
- Draw a rough graph to show the pattern predicted in the previous question.

Solution:

a) As you move across a period the first ionisation energy increases. This is because we are adding an electron every time we increase atomic number. As we move closer to filling

the outermost shell the element would rather gain electrons than lose them and this is seen in the higher ionisation energies.

b) The pattern should be the same.

c)

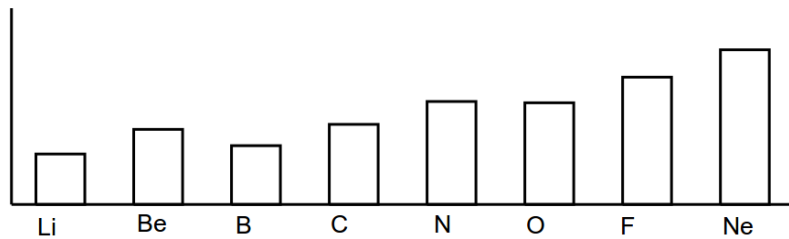

Chapter 6. Chemical bonding

Exercise 6-1:

1. Represent each of the following atoms using Lewis notation:

- a) Beryllium
- b) Calcium
- c) Lithium

Solution:

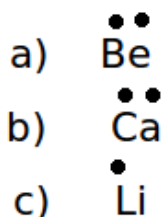

2. Represent each of the following molecules using Lewis notation:

- a) Bromine gas (Br_2)
- b) Carbon dioxide (CO_2)

Which of these two molecules contains a double bond?

Solution:

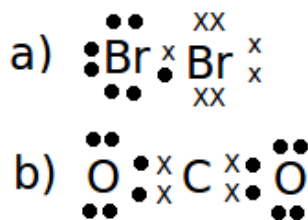

Carbon dioxide contains a double bond, since there are two pairs of electrons between carbon and oxygen.

3. Two chemical reactions are described below:

- nitrogen and hydrogen react to form NH_3
- carbon and hydrogen bond to form a molecule of CH_4

For each reaction, give:

- a) the number of electrons in the outermost energy level

- b) the Lewis structure of the product that is formed
 c) the name of the product

Solution

a) Reaction 1: nitrogen: 5 hydrogen: 1

Reaction 2: carbon: 4 hydrogen: 1

b)

Reaction 1:

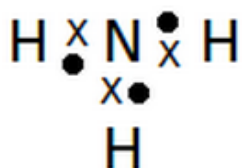

Reaction 2:

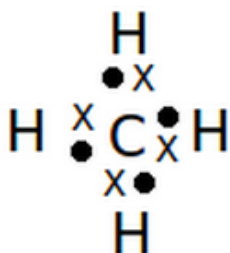

c) Reaction 1: ammonia, Reaction 2: methane

4. A chemical compound has the following Lewis notation:

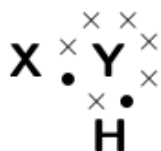

a) How many valence electrons does element Y have?

- b) What is the valency of element Y?
- c) What is the valency of element X?
- d) How many covalent bonds are in the molecule?
- e) Suggest a name for elements X and Y.

Solution:

- a) 6. There are 6 crosses around element Y and from our knowledge of Lewis diagrams we know that these represent the valence electrons.
- b) 2. Y can form two bonds and so its valency is 2.
- c) 1. X can only form one bond.
- d) 2. From our knowledge of Lewis diagrams we look at how many cross and dot pairs there are in the molecule and that gives us the number of covalent bonds.
- e) The most likely atoms are: Y: oxygen and X: hydrogen.

Note that Y could also be sulphur and X still hydrogen and the molecule would then be hydrogen sulphide (sulphur dihydride).

Exercise 6-2:

1. Explain the difference between the valence electrons and the valency of an element.

Solution:

Valence electrons are the number of electrons in the outermost energy level of an atom. Valency is the number of electrons an atom needs to gain or lose in order to have a full outermost energy level.

2. Complete the table below by filling in the number of valence electrons for each of the elements shown:

Element	Group number	No. of valence electrons	No. of electrons needed to fill outermost shell
He			
Li			
B			
C			
F			
Ne			
Na			
Al			

P			
S			
Ca			
Kr			

Solution

Element	Group number	No. of valence electrons	No. of electrons needed to fill outermost shell
He	18	2	0
Li	1	1	7
B	13	3	5
C	14	4	4
F	7	1	1
Ne	18	8	0
Na	1	1	7
Al	13	3	5
P	15	5	3
S	16	6	2
Ca	2	2	6
Kr	18	8	0

3. Draw simple diagrams to show how electrons are arranged in the following covalent molecules:

- Hydrogen sulphide (H_2S)
- Chlorine (Cl_2)
- Nitrogen (N_2)
- Carbon monoxide (CO)

Solution:

a)

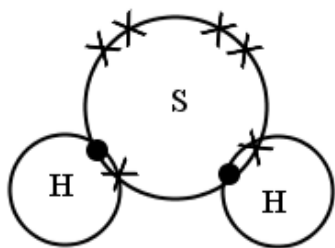

b)

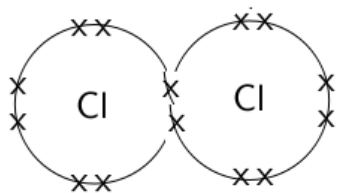

c)

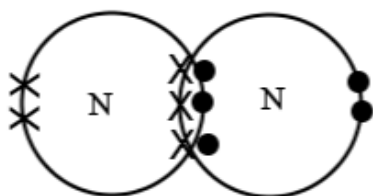

d)

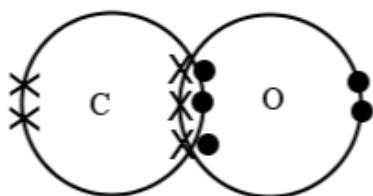

Exercise 6-3:

1. Explain the difference between a covalent and an ionic bond.

Solution:

A covalent bond involves sharing of electrons while an ionic bond involves transfer of electrons. In a covalent bond the electronegativity difference is less than 1.7 while in an ionic bond the electronegativity difference is greater than 1.7.

2. Magnesium and chlorine react to form magnesium chloride.

a) What is the difference in electronegativity between these two elements?

- b) Give the chemical formula for:
- a magnesium ion
 - a chloride ion
 - the ionic compound that is produced during this reaction
- c) Write a balanced chemical equation for the reaction that takes place.

Solution:

a) Mg: 1.2

Cl: 3.0

The electronegativity difference is: $3.0 - 1.2 = 1.8$

b) i) Magnesium ion: Mg^{2+}

ii) Chloride ion: Cl^-

iii) Magnesium chloride: MgCl_2

c) $2\text{Mg} + \text{Cl}_2 \rightarrow 2\text{MgCl}_2$

3. Draw Lewis diagrams to represent the following ionic compounds:

- sodium iodide (NaI)
- calcium bromide (CaBr_2)
- potassium chloride (KCl)

Solution:

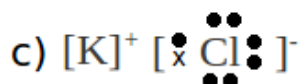
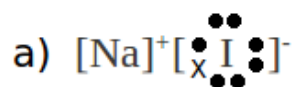

Exercise 6-4:

1. Give two examples of everyday objects that contain:

- a) covalent bonds
- b) ionic bonds
- c) metallic bonds

Solution:

Learners can give any reasonable suggestion, some ideas are given below:

- a) Graphite in pencils, water
- b) Table salt,
- c) Metal cutlery, metal jewellery

2. Complete the table which compares the different types of bonding:

	Covalent	Ionic	Metallic
Types of atoms involved			
Nature of bonds between atoms			
Melting point (high/low)			
Conducts electricity? (yes/no)			
Other properties			

Solution:

	Covalent	Ionic	Metallic
Types of atoms involved	Mainly non-metals	Some non-metals and some metals	Metals only
Nature of bonds between atoms	Sharing of electrons	Transfer of electrons	Delocalisation of electrons
Melting point (high/low)	Low	High	High
Conducts electricity? (yes/no)	No	Only when molten or in solution	Yes
Other properties	Poor conductor of heat	Brittle	Malleable, shiny, ductile

3. Complete the table below by identifying the type of bond (covalent, ionic or metallic) in each of the compounds:

Molecular formula	Type of bond
H ₂ SO ₄	
FeS	
NaI	
MgCl ₂	
Zn	

Solution:

Molecular formula	Type of bond
H ₂ SO ₄	covalent
FeS	ionic
NaI	ionic
MgCl ₂	ionic
Zn	metallic

4. Use your knowledge of the different types of bonding to explain the following statements:

- A sodium chloride crystal does not conduct electricity.
- Most jewellery items are made from metals.
- It is very hard to break a diamond.
- Pots are made from metals, but their handles are made from plastic.

Solution:

- In a solid ionic substance there are no free electrons and so charge cannot flow.
- Metals are shiny and malleable. The malleability means that it can be formed into many shapes. Jewellery is designed to be pretty and attractive and so shiny materials would be preferred over non-shiny materials.
- Diamond is covalently bonded. Covalent bonds are very strong bonds and it is hard to break them.
- Metal is a good conductor of heat, while plastic is a poor conductor of heat. When you

cook food you need the pot to be a good conductor of heat but the handles should be poor conductors of heat so that you don't burn yourself.

Exercise 6-5:

1. Write the chemical formula for each of the following compounds:

- hydrogen cyanide
- carbon dioxide
- sodium carbonate
- ammonium hydroxide
- barium sulphate
- copper (II) nitrate

Solution:

- HCN
- CO₂
- NaCO₃
- NH₄OH
- BaSO₄
- Cu(NO₃)₂

2. Complete the following table. The cations at the top combine with the anions on the left. The first row is done for you. Also include the names of the compounds formed and the anions.

	Na ⁺	Mg ²⁺	Al ³⁺	NH ₄ ⁺	H ⁺
Br ⁻ Name:	NaBr Sodium bromide	MgBr ₂ Magnesium bromide	AlBr ₃ Aluminium bromide	(NH ₄)Br Ammonium bromide	HBr Hydrogen bromide
S ²⁻ Name:					
P ³⁻ Name:					
MnO ₄ ⁻ Name:					
Cr ₂ O ₇ ²⁻ Name:					
HPO ₄ ²⁻ Name:					

Solution:

	Na^+	Mg^{2+}	Al^{3+}	NH_4^+	H^+
Br^- Name:	NaBr Sodium bromide	$MgBr_2$ Magnesium bromide	$AlBr_3$ Aluminium bromide	$(NH_4)Br$ Ammonium bromide	HBr Hydrogen bromide
S^{2-} Name:	Na_2S Sodium sulphide	MgS magnesium sulphide	Al_2S_3 aluminium sulphide	$(NH_4)_2S$ ammonium sulphide	H_2S hydrogen sulphide
P^{3-} Name:	Na_3P sodium phosphide	Mg_3P_2 magnesium phosphide	AlP aluminium phosphide	$(NH_4)_3P$ ammonium phosphide	H_3P hydrogen phosphide
MnO_4^- Name:	$NaMnO_4$ sodium permanganate	$Mg(MnO_4)_2$ magnesium permanganate	$Al(MnO_4)_3$ aluminium permanganate	NH_4MnO_4 ammonium permanganate	$HMnO_4$ hydrogen permanaganate
$Cr_2O_7^{2-}$ Name:	$Na_2Cr_2O_7$ sodium dichromate	$MgCr_2O_7$ magnesium dichromate	$Al_2(Cr_2O_7)_3$ aluminium dichromate	$(NH_4)_2MnO_4$ ammonium dichromate	$H_2Cr_2O_7$ hydrogen dichromate
HPO_4^{2-} Name:	Na_2HPO_4 sodium hydrogen phosphate	$Mg(HPO_4)_2$ magnesium hydrogen phosphate	$Al_2(HPO_4)_3$ aluminium hydrogen phosphate	$(NH_4)_2HPO_4$ ammonium hydrogen phosphate	H_3PO_4 phosphoric acid

End of chapter exercises

1. Explain the meaning of each of the following terms:

- ionic bond
- covalent bond

Solution:

- Bonding that occurs between two atoms with a difference in electronegativity greater than 1.7
- Bonding that occurs between two atoms with a difference in electronegativity of between 0 and 1.7

2. Which ONE of the following best describes the bond formed between carbon and hydrogen ?

- a) ionic bond
- b) covalent bond
- c) metallic bond

Solution:

- b) covalent bond

3. Which of the following reactions will not take place? Explain your answer.

- a) $H + H \rightarrow H_2$
- b) $Ne + Ne \rightarrow Ne_2$
- c) $Cl + Cl \rightarrow Cl_2$

Solution:

Reaction b will not take place as neon does not have electrons available for bonding. Neon is a noble gas and has a full outer shell of electrons.

4. Draw the Lewis structure for each of the following:

- a. calcium
- b. iodine
- c. hydrogen bromide (HBr)
- d. nitrogen dioxide (NO_2)

Solution

a)

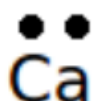

b)

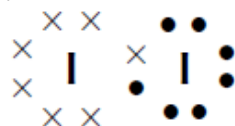

c)

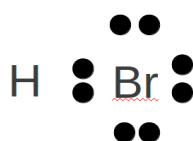

d)

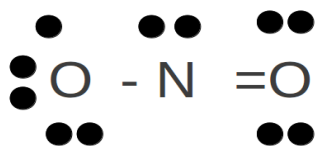

5. Given the following Lewis structure, where X and Y each represent a different element...

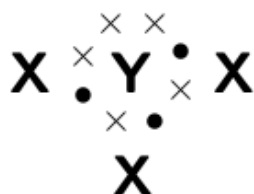

- What is the valency of X?
- What is the valency of Y?
- Which elements could X and Y represent?

Solution:

- X has a valency of 1.
- Y has a valency of 3.
- X could be hydrogen and Y could be nitrogen.

6. Complete the following table:

	K^+	Ca^{2+}	NH_4^+
OH^-			
O^{2-}			
NO_3^-			
PO_4^{3-}			

Solution:

	K^+	Ca^{2+}	NH_4^+
OH^-	KOH	$Ca(OH)_2$	NH_4OH
O^{2-}	K_2O	CaO	$(NH_4)_2O$
NO_3^-	KNO_3	$Ca(NO_3)_2$	NH_4NO_3
PO_4^{3-}	K_3PO_4	$Ca_3(PO_4)_2$	$(NH_4)_3PO_4$

7. Potassium dichromate is dissolved in water.

- Give the name and chemical formula for each of the ions in solution.
- What is the chemical formula for potassium dichromate?

Solution:

a) Potassium ion and dichromate ion.

Potassium: K^+

Dichromate: $Cr_2O_7^{2-}$

b) $K_2Cr_2O_7$

Chapter 7. Transverse pulses

Exercise 7-1:

1. A pulse covers a distance of 5 m in 15 seconds. Calculate the speed of the pulse.

Solution:

$$v = \frac{D}{t} = \frac{5 \text{ m}}{1,5 \text{ s}} = 3,3 \text{ m} \cdot \text{s}^{-1}$$

2. A pulse has a speed of 5 cm · s⁻¹. How far does it travel in 2,5 seconds?

Solution:

$$D = v \cdot t = (5 \text{ cm} \cdot \text{s}^{-1})(2,5 \text{ s}) = 12,5 \text{ m}$$

3. A pulse has a speed of 0,5 m · s⁻¹. How long does it take to cover a distance of 25 cm ?

Solution:

$$\begin{aligned} t &= \frac{D}{v} = \frac{2,5 \text{ cm}}{0,5 \text{ m} \cdot \text{s}^{-1}} \\ &= \frac{2,5 \text{ cm}}{50 \text{ cm} \cdot \text{s}^{-1}} \\ &= 0,5 \text{ s} \end{aligned}$$

4. How long will it take a pulse moving at 0,25 m · s⁻¹ to travel a distance of 20 m ?

Solution:

$$t = \frac{D}{v} = \frac{20 \text{ m}}{0,25 \text{ m} \cdot \text{s}^{-1}} = 80 \text{ s}$$

5. The diagram shows two pulses in the same medium. Which has the higher speed? Explain your answer.

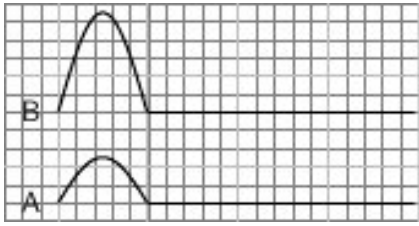

Solution:

Both move at the same speed. The amplitude of a pulse is independent of the speed with which the pulse propagates through a medium; the speed of propagation of a wave through a medium is dependent only on the medium.

Exercise 7-2:

1. For the following pulse, draw the resulting wave forms after 1 s, 2 s, 3 s, 4 s and 5 s. Each pulse is travelling at $1 \text{ m} \cdot \text{s}^{-1}$. Each block represents 1 m. The pulses are shown as thick black lines and the undisplaced medium as dashed lines.

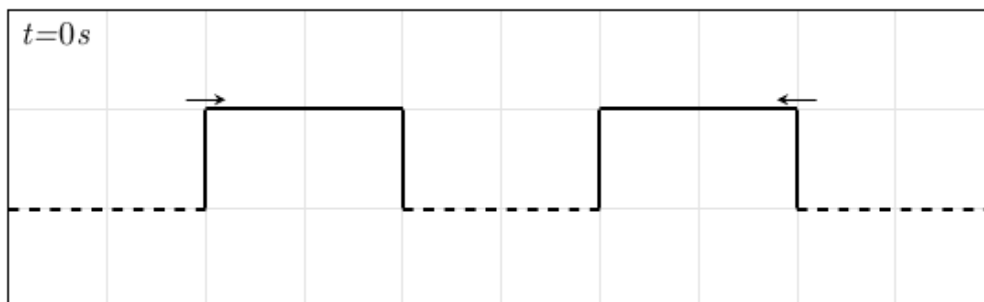

Solution:

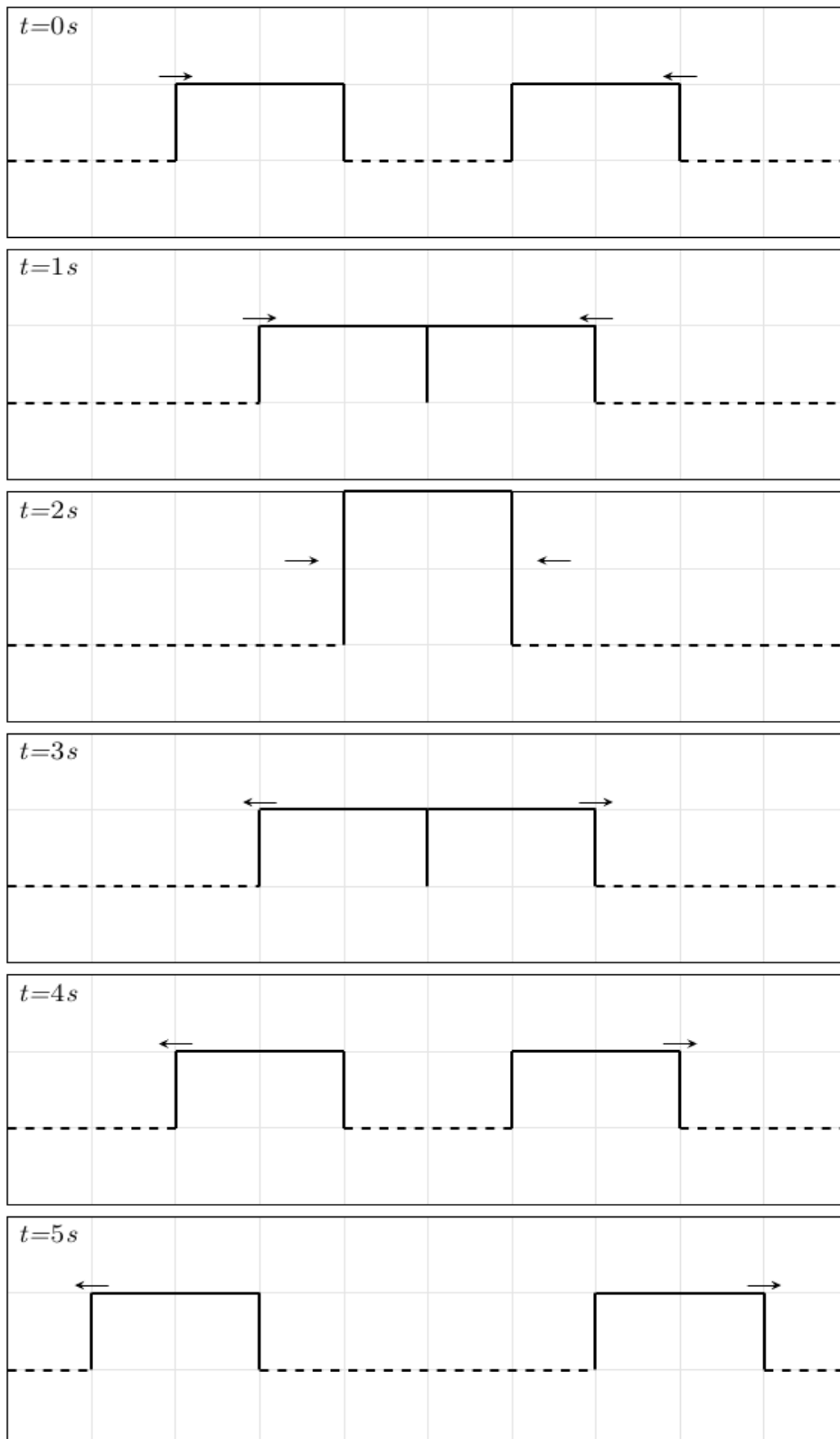

2. For the following pulse, draw the resulting wave forms after 1 s, 2 s, 3 s, 4 s and 5 s. Each pulse is travelling at $1 \text{ m}\cdot\text{s}^{-1}$. Each block represents 1 m. The pulses are shown as thick black lines and the undisplaced medium as dashed lines.

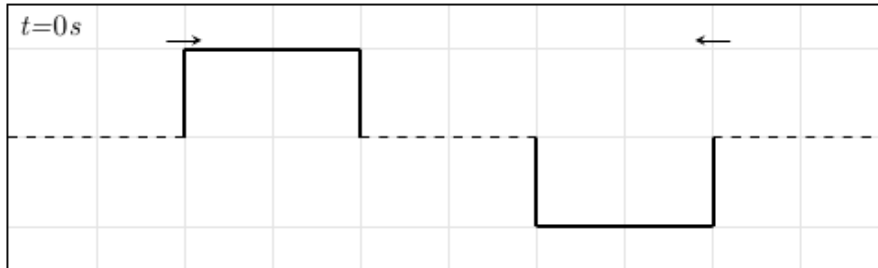

Solution:

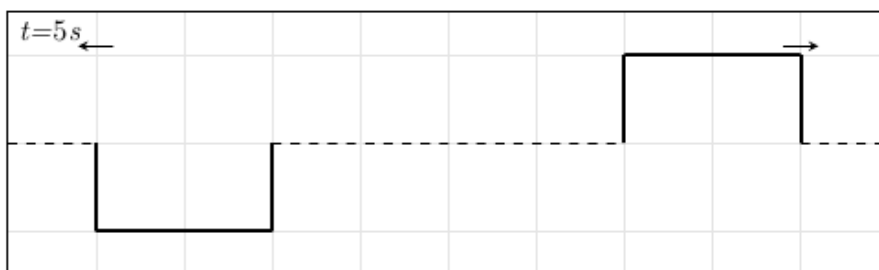
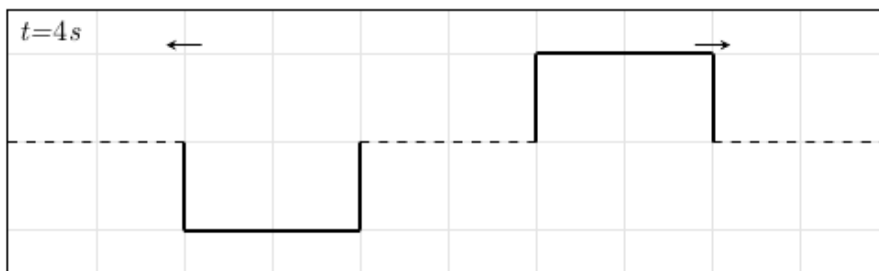
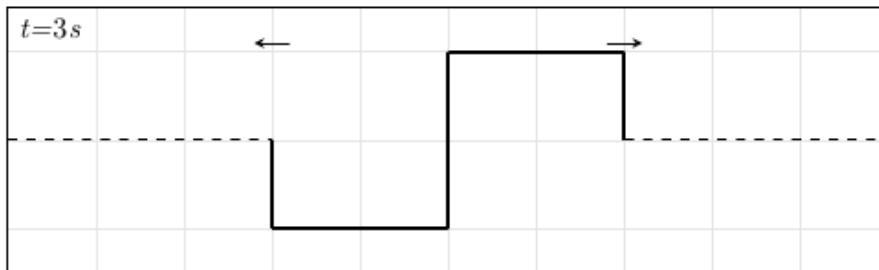
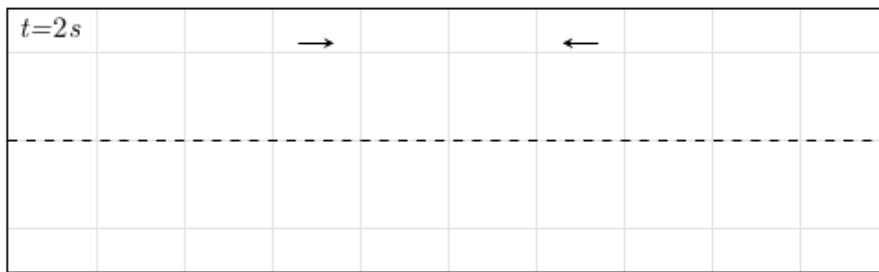
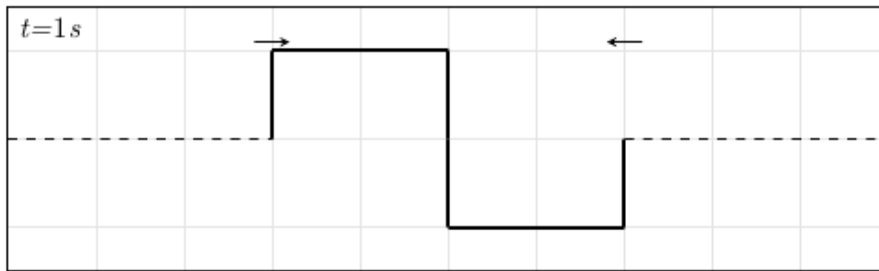
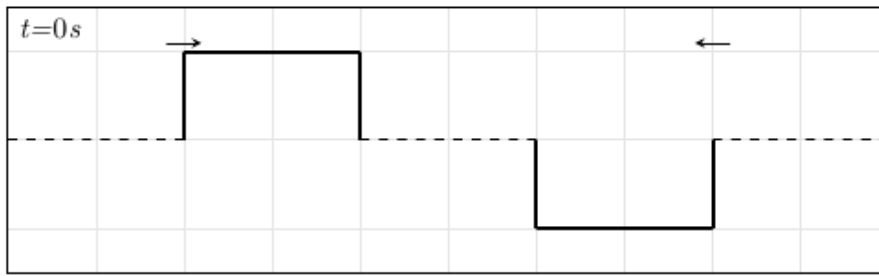

3. For the following pulse, draw the resulting wave forms after 1 s, 2 s, 3 s, 4 s and 5 s. Each pulse is travelling at $1 \text{ m} \cdot \text{s}^{-1}$. Each block represents 1 m. The pulses are shown as thick black lines and the undisplaced medium as dashed lines.

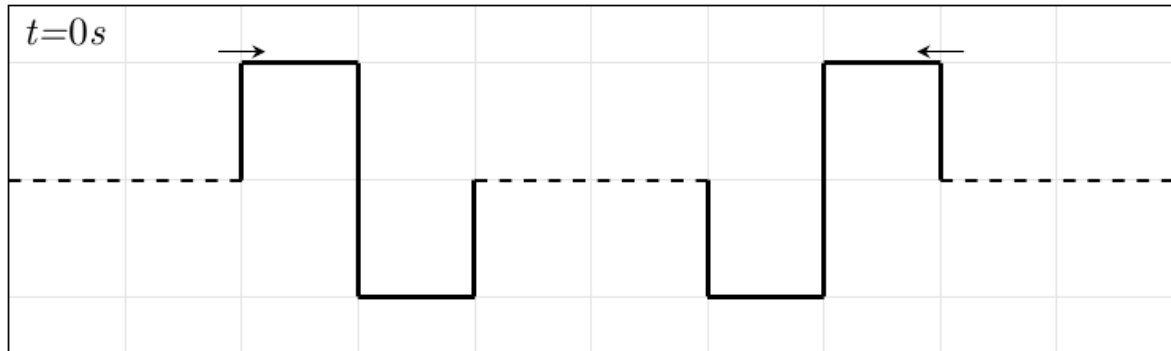

Solution:

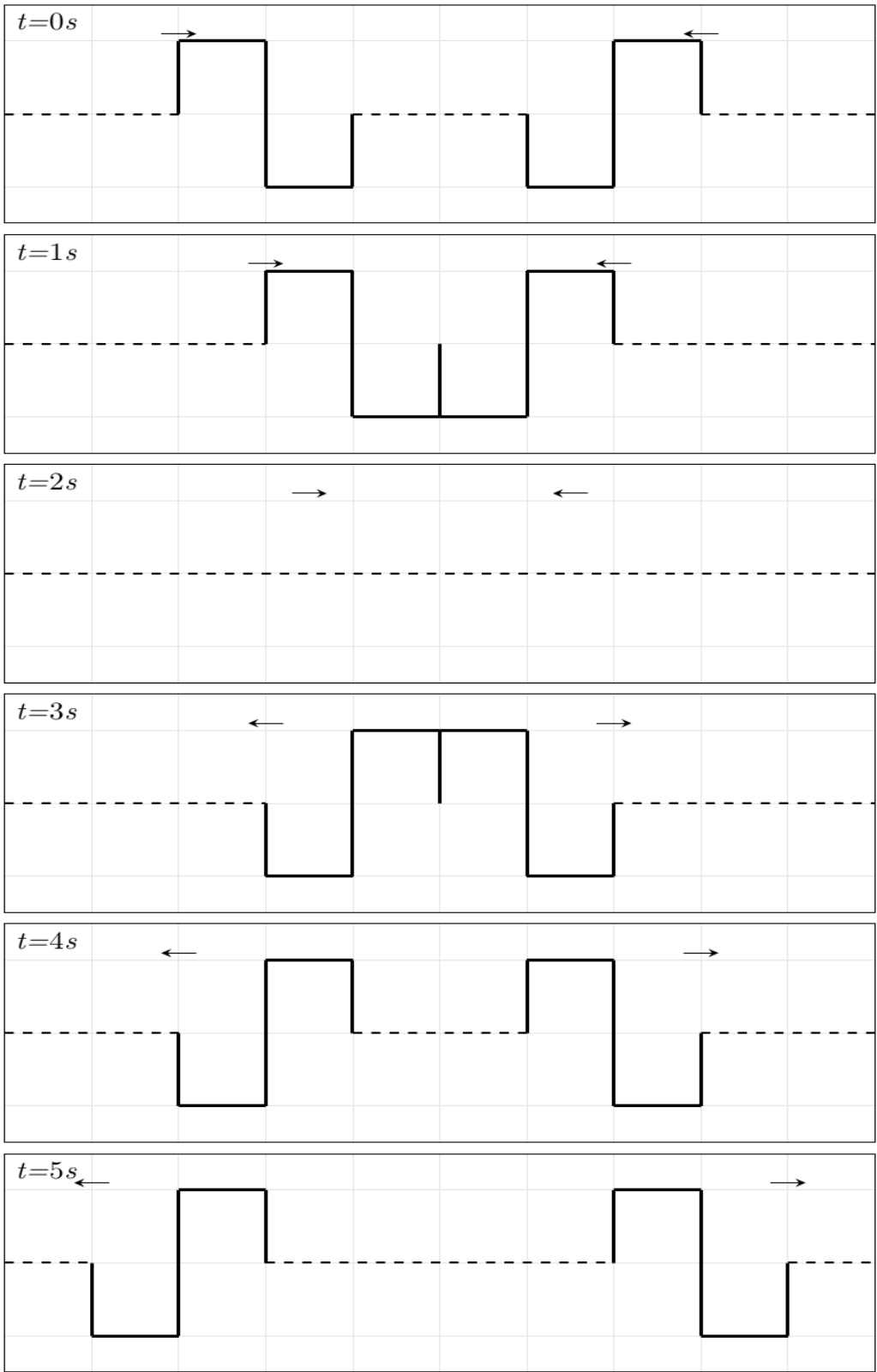

4. For the following pulse, draw the resulting wave forms after 1 s, 2 s, 3 s, 4 s and 5 s. Each pulse is travelling at $1 \text{ m}\cdot\text{s}^{-1}$. Each block represents 1 m. The pulses are shown as thick black lines and the undisplaced medium as dashed lines.

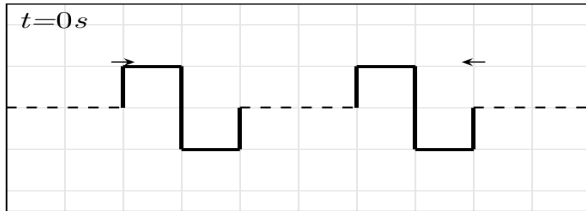

Solution:

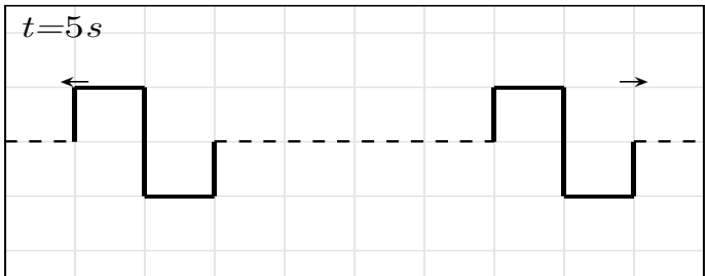
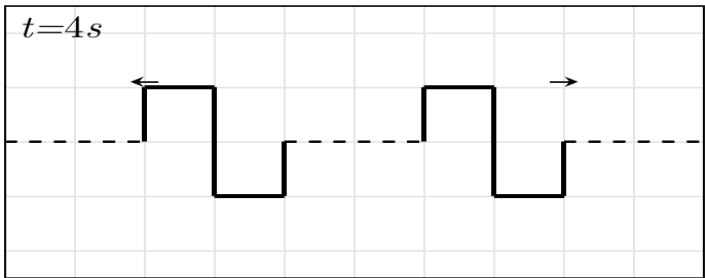
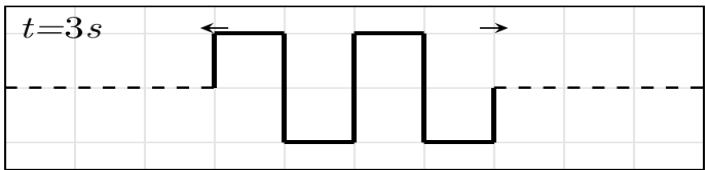
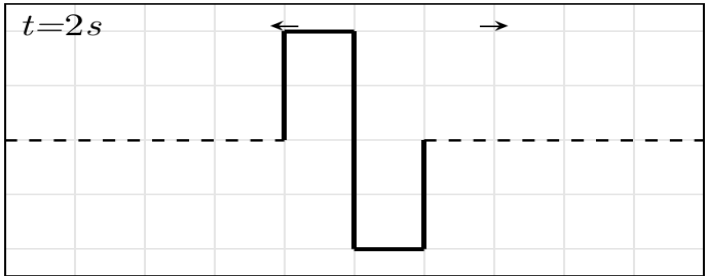
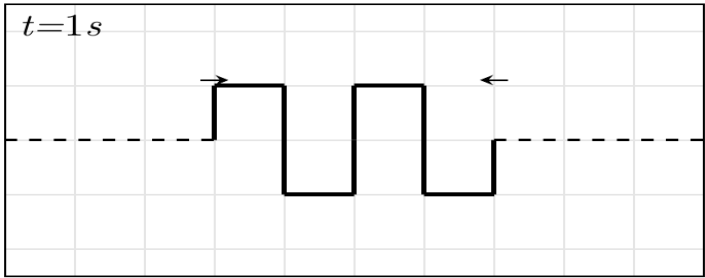
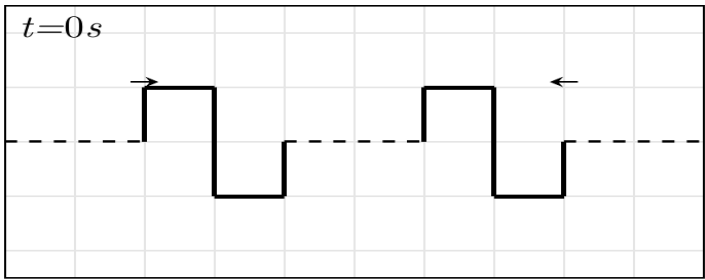

5. For the following pulse, draw the resulting wave forms after 1 s, 2 s, 3 s, 4 s and 5 s. Each pulse is travelling at $1 \text{ m} \cdot \text{s}^{-1}$. Each block represents 1 m. The pulses are shown as thick black lines and the undisplaced medium as dashed lines.

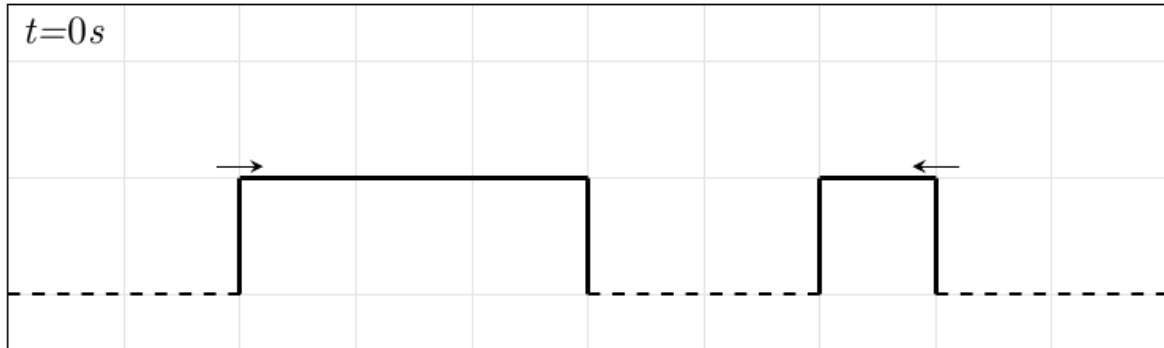

Solution:

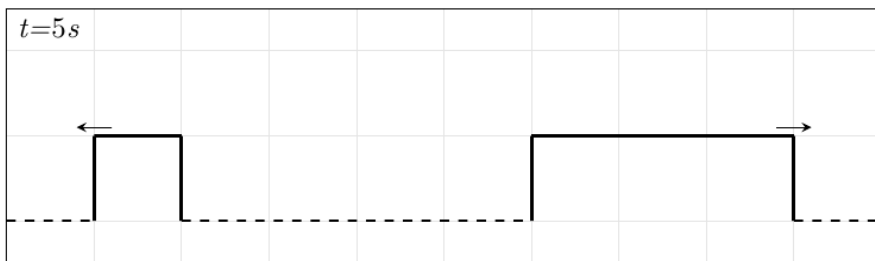
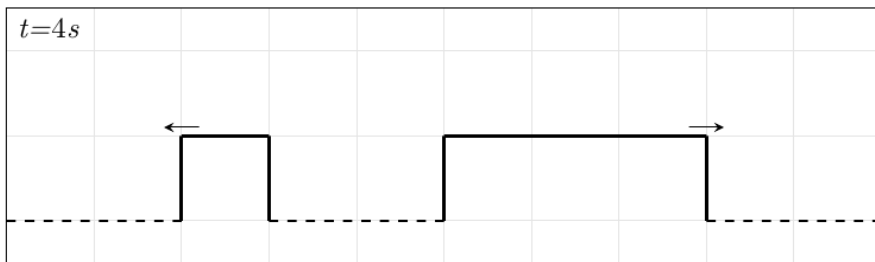
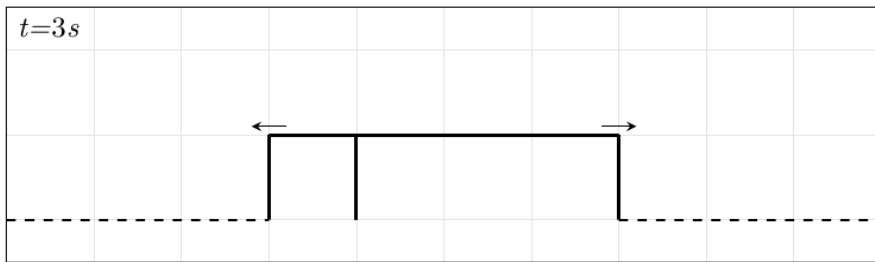
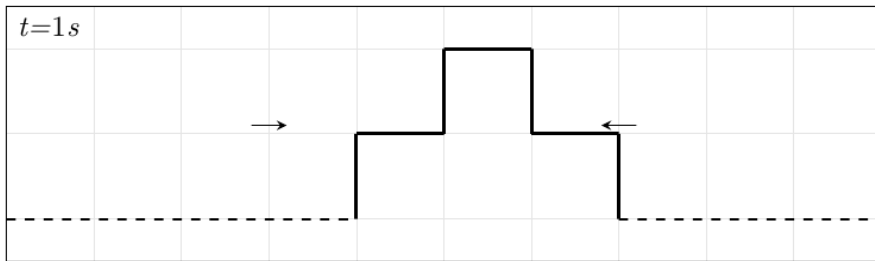
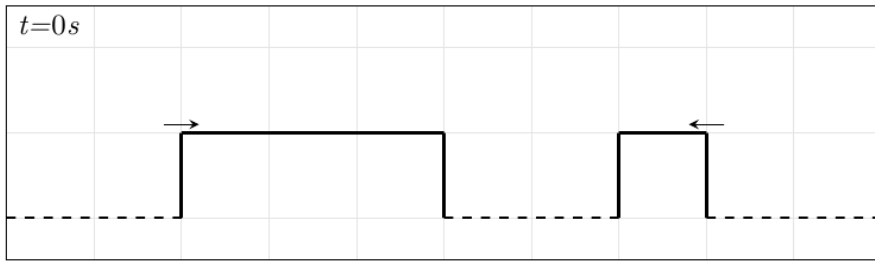

6. For the following pulse, draw the resulting wave forms after 1 s, 2 s, 3 s, 4 s and 5 s. Each pulse is travelling at $1 \text{ m} \cdot \text{s}^{-1}$. Each block represents 1 m. The pulses are shown as thick black lines and the undisplaced medium as dashed lines.

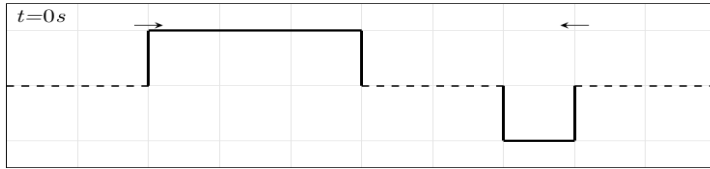

Solution:

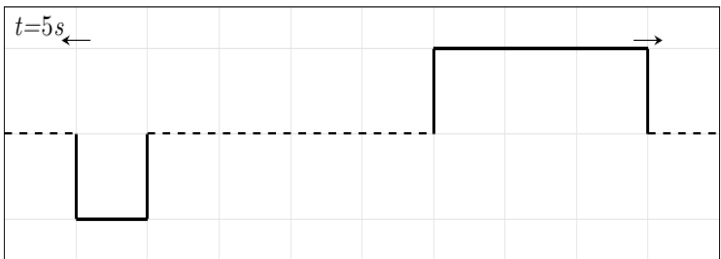
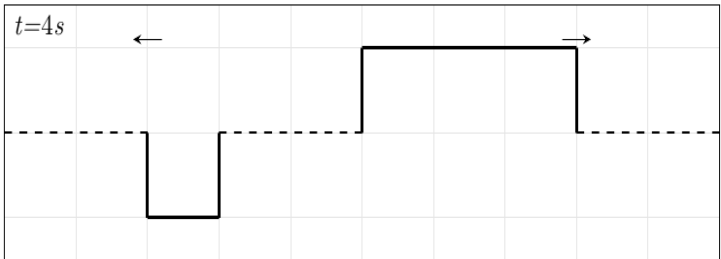
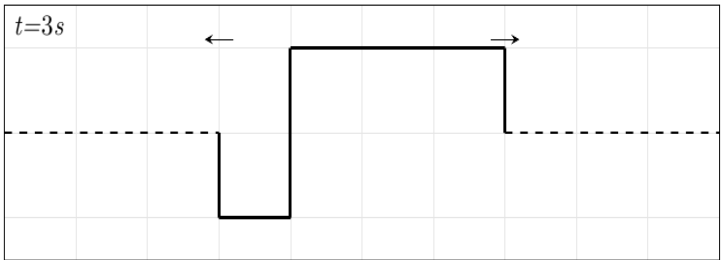
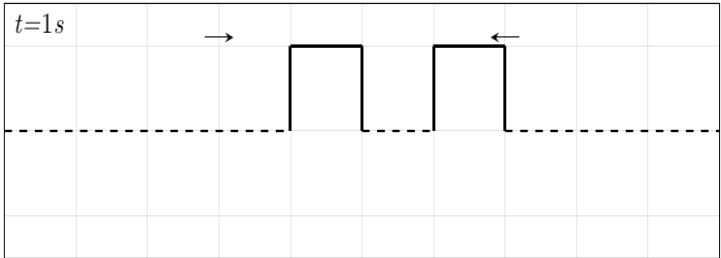
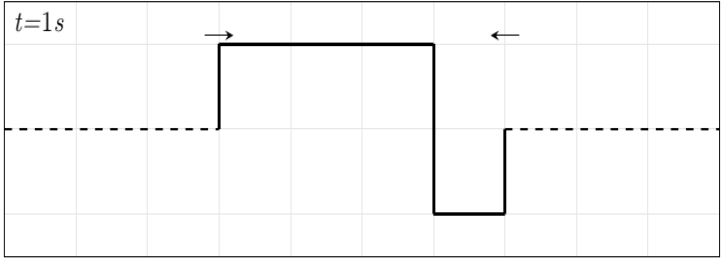
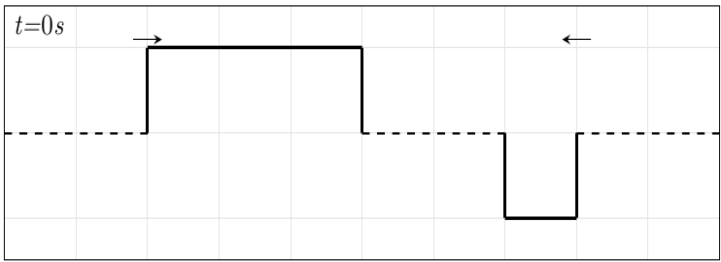

7. What is superposition of waves?

Solution:

The superposition of waves is when two waves travel through the same medium and meet.

8. What is constructive interference?

Solution:

Constructive interference is when two or more waves meet and the resulting pulse is larger than its components.

9. What is destructive interference?

Solution:

Destructive interference is when two or more waves meet and the resulting pulse is smaller than its components.

End of chapter exercises:

1. A heavy rope is flicked upwards, creating a single pulse in the rope. Make a drawing of the rope and indicate the following in your drawing:

- The direction of motion of the pulse
- Amplitude
- Pulse length
- Position of rest

Solution:

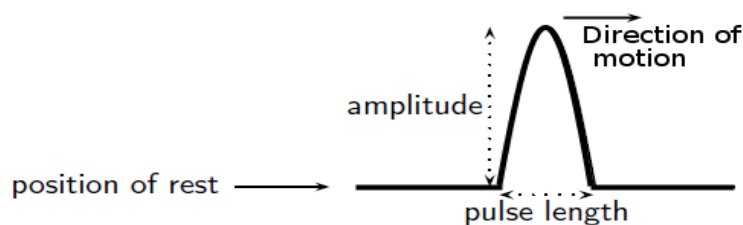

2. A pulse has a speed of $2,5 \text{ m}\cdot\text{s}^{-1}$. How far will it have travelled in 6 s?

Solution:

$$\begin{aligned} D &= v t \\ &= (2,5 \text{ m}\cdot\text{s}^{-1})(6 \text{ s}) \\ &= 15 \text{ m} \end{aligned}$$

3. A pulse covers a distance of 75 cm in 2,5 s. What is the speed of the pulse?

Solution:

$$\begin{aligned} v &= \frac{D}{t} \\ &= \frac{(75 \text{ cm})}{(2,5 \text{ s})} \\ &= 30 \text{ cm}\cdot\text{s}^{-1} = 0,30 \text{ m}\cdot\text{s}^{-1} \end{aligned}$$

4. How long does it take a pulse to cover a distance of 200 mm if its speed is $4 \text{ m}\cdot\text{s}^{-1}$?

Solution:

$$\begin{aligned} t &= \frac{D}{v} \\ &= \frac{(200 \text{ mm})}{(4 \text{ m}\cdot\text{s}^{-1})} \\ &= \frac{0,2 \text{ m}}{4 \text{ m}\cdot\text{s}^{-1}} \\ &= 0,05 \text{ s} \end{aligned}$$

The following question has been removed from the book, but left here as additional material.

5. In a rope, a pulse of amplitude +20 mm is travelling to the right and a pulse of amplitude -4 mm is travelling to the left.

a) Make a labelled sketch to represent these two pulses.

b) What type of interference will take place when these two pulses meet?

c) Make a labelled sketch to represent the resulting pulse:

i) when they cross each other

ii) after they have crossed each other

Solution:

a)

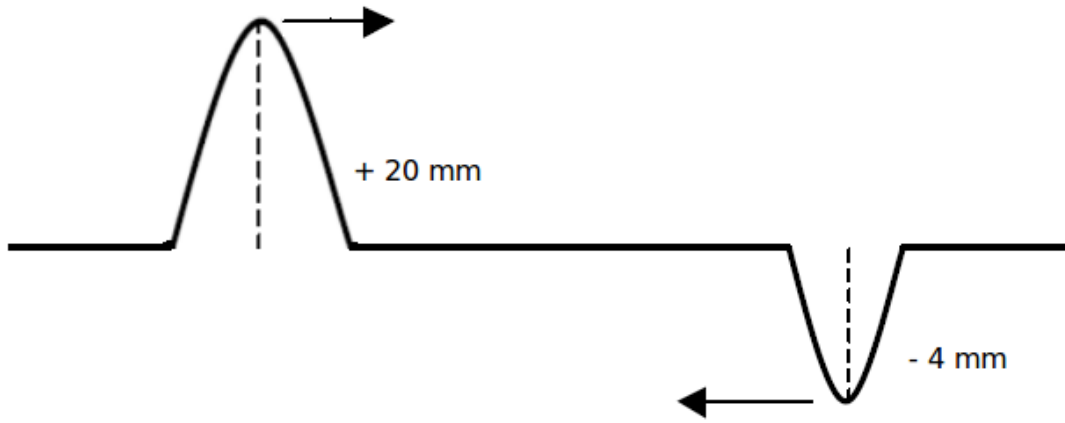

b) Destructive interference

c.i)

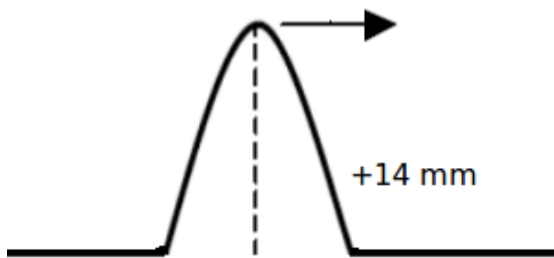

c.ii)

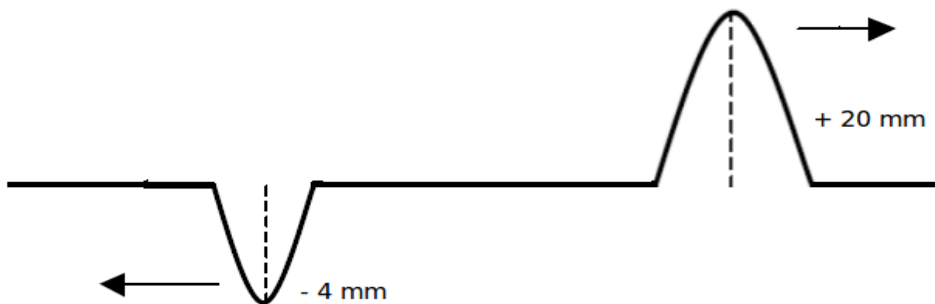

Chapter 8. Transverse waves

Exercise 8-1:

1. When the particles of a medium move perpendicular to the direction of the wave motion, the wave is called a wave.

Solution:

transverse

2. A transverse wave is moving downwards. In what direction do the particles in the medium move?

Solution:

The particles will move sideways, perpendicular to the direction of the wave.

3. Consider the diagram below and answer the questions that follow:

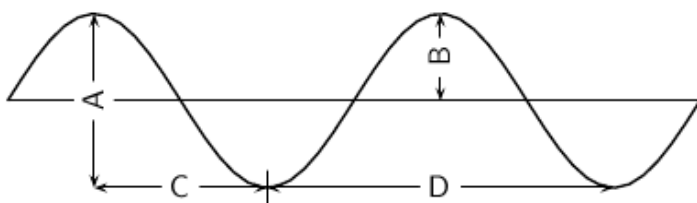

a) the wavelength of the wave is shown by letter ...

b) the amplitude of the wave is shown by letter ...

Solution:

a) D

b) B

4. Draw 2 wavelengths of the following transverse waves on the same graph paper. Label all important values.

a) Wave 1: Amplitude = 1 cm, wavelength = 3 cm

b) Wave 2: Peak to trough distance (vertical) = 3 cm, crest to crest distance (horizontal) = 5 cm

Solution:

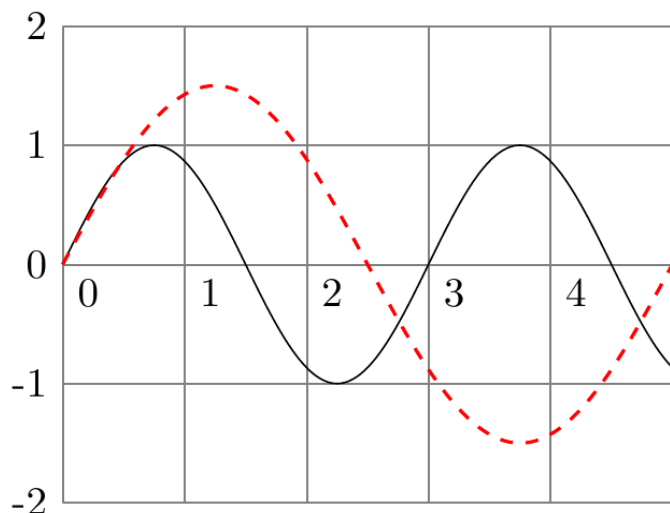

The transverse waves are given in the figure above. Wave 1 is the solid black line. Wave 2 is the dashed red line that has an amplitude of 1.5 cm and a wavelength of 5 cm.

5. You are given the transverse wave below:

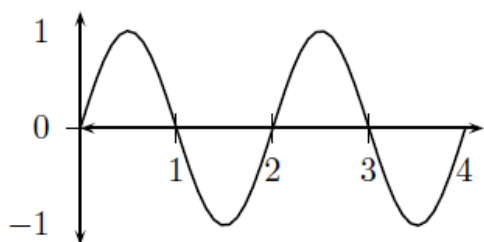

Draw the following:

- A wave with twice the amplitude of the given wave.
- A wave with half the amplitude of the given wave.
- A wave travelling at the same speed with twice the frequency of the given wave.
- A wave travelling at the same speed with half the frequency of the given wave.
- A wave with twice the wavelength of the given wave.
- A wave with half the wavelength of the given wave.
- A wave travelling at the same speed with twice the period of the given wave.
- A wave travelling at the same speed with half the period of the given wave.

Solution:

- Twice the amplitude is 2 cm.

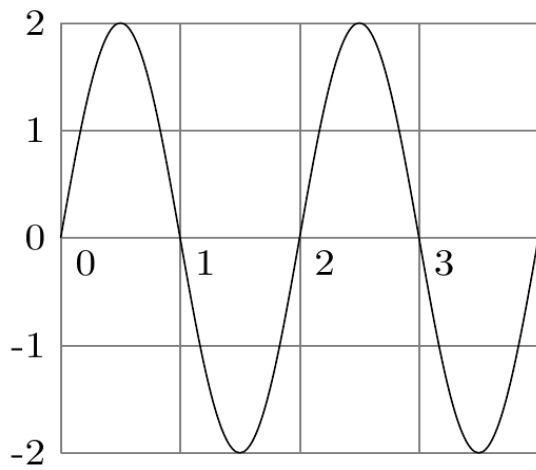

b) Half the amplitude is 0,5 cm.

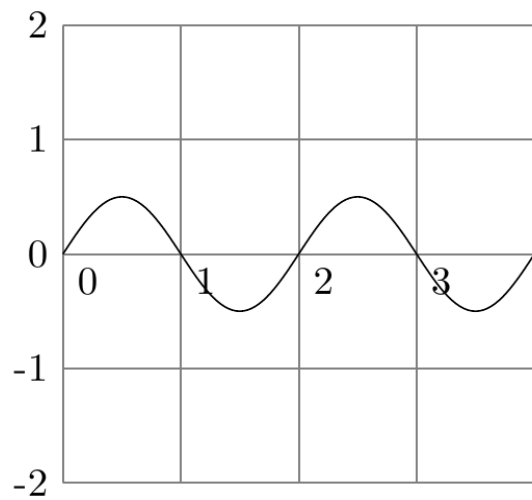

c) $v = f \lambda = \frac{2}{2} f \lambda = (2f) \left(\frac{\lambda}{2}\right)$ thus if we have twice the frequency we have half the wavelength which is 1 cm.

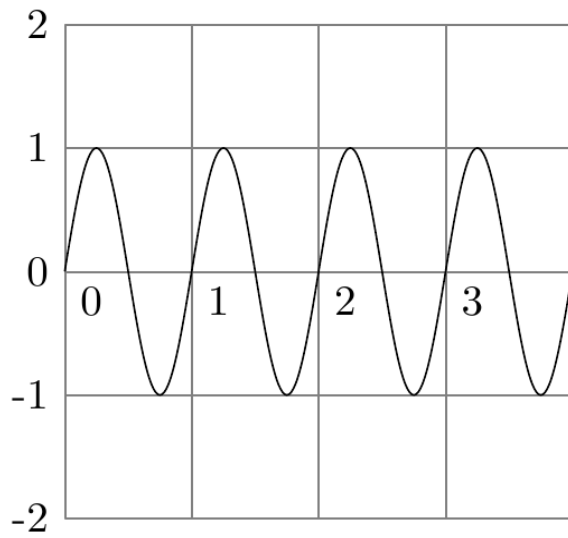

d) $v = f\lambda = \frac{2}{2}f\lambda = (\frac{f}{2})(2\lambda)$ thus if we have half the frequency we have twice the wavelength which is 4 cm.

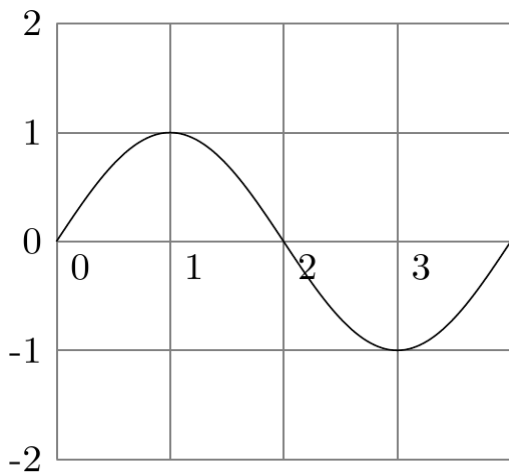

e) Twice the wavelength is 4 cm.

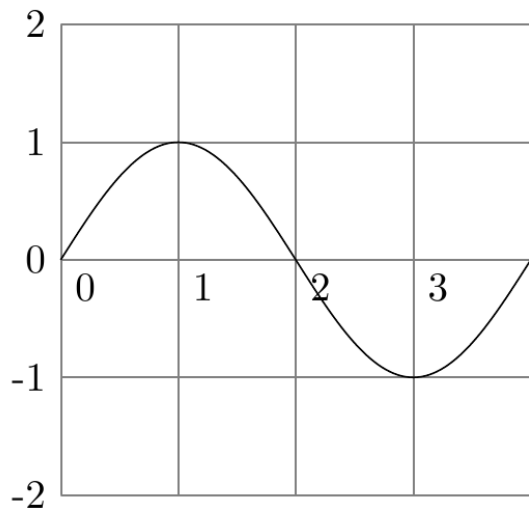

f) Half the wavelength is 1 cm.

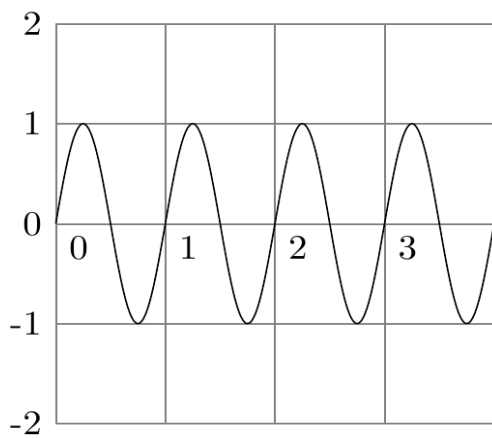

g) $v = \frac{\lambda}{T} = \frac{2\lambda}{T}$ thus if you have twice the period we have twice the wavelength which is 4 cm.

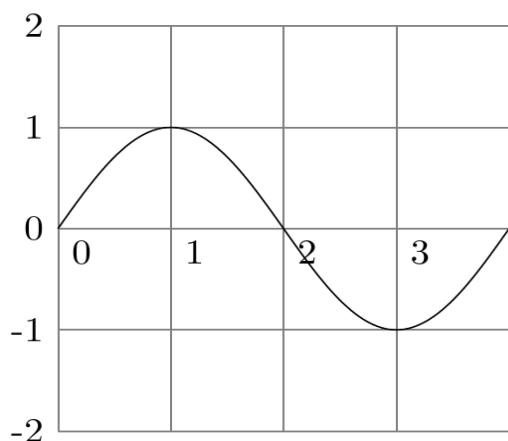

h) $v = \frac{\lambda}{T} = \frac{2\lambda}{2T} = (\frac{1}{2}\lambda) \div (\frac{1}{2}T)$ thus if you have twice the period we have twice the wavelength which is 4 cm.

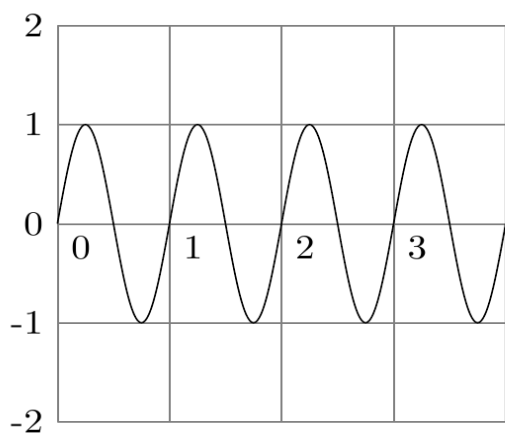

6. A transverse wave travelling at the same speed with an amplitude of 5 cm has a frequency of 15 Hz. The horizontal distance from a crest to the nearest trough is measured to be 2,5 cm. Find the
- period of the wave.
 - speed of the wave.

Solution:

$$a) \quad T = \frac{1}{f}$$

$$T = \frac{1}{15}$$

$$T = 0,067 \text{ s}$$

The period of the wave is 0,067 s

b) The horizontal distance from peak to trough is half the wavelength, so the wavelength is 5 cm.

The speed is:

$$v = \lambda \cdot f$$

$$v = (5 \text{ cm})(15 \text{ s}^{-1})$$

$$v = 75 \text{ cm} \cdot \text{s}^{-1}$$

$$v = 0,75 \times 10^{-2} \text{ m} \cdot \text{s}^{-1}$$

7. A fly flaps its wings back and forth 200 times each second. Calculate the period of a wing flap.

Solution:

The frequency of the wing flap is 200 Hz. (In one second the fly flaps its wings 200 times).

The period is:

$$T = \frac{1}{f} = \frac{1}{200} = 0,005 \text{ s}$$

8. As the period of a wave increases, the frequency increases/decreases/does not change

Solution:

The frequency will decrease. The frequency is inversely related to the period and so when the period increases, the frequency will decrease.

9. Calculate the frequency of rotation of the second hand on a clock.

Solution:

In one minute, the second hand moves 60 times, in other words it moves at a speed of one unit per second in one revolution for 60 units. And the revolution has a period of 60 seconds.

$$f = \frac{1}{T} = \frac{1}{60} = 0,017 \text{ Hz}$$

10. Microwave ovens produce radiation with a frequency of 2 450 MHz ($1\text{MHz}=10^6\text{Hz}$) and a wavelength of 0,122 m. What is the wave speed of the radiation?

Solution:

$$v = \lambda \cdot f$$

$$v = (0,122)(2450 \times 10^6)$$

$$v = 2,99 \times 10^8 \text{ m} \cdot \text{s}^{-1}$$

11. Study the following diagram and answer the questions:

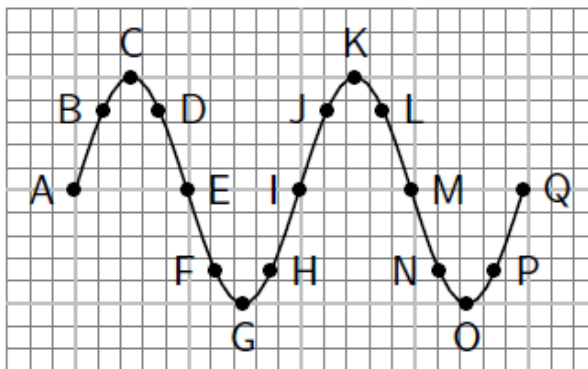

- Identify two sets of points that are in phase.
- Identify two sets of points that are out of phase.
- Identify any two points that would indicate a wavelength.

Solution:

a) There are many sets of points, they are: (C,K), (G, O) , (E, M), (A, I), (I, Q), (B, J), (D, L), (F, N) and (H, P). Two points will be in phase if they occur in the same position on a wave, so the two peaks and the two troughs are in phase.

b) Points out of phase would be any pair of points not mentioned in (a). For example, A and F, B and Q, etc.

c) C and K or G and O. As well as any other two points that are in phase as in (a). A wavelength is the distance from one peak to the next or from one trough to the next.

12. Tom is fishing from a pier and notices that four wave crests pass by in 8 s and estimates the distance between two successive crests is 4 m. The timing starts with the first crest and ends with the fourth. Calculate the speed of the wave.

Solution:

The wavelength is 4 m, since this is the distance between successive crests. The period is 2 sec since four waves pass in 8 seconds.

Therefore the speed is:

$$v = \frac{\lambda}{T}$$

$$v = \frac{4}{2}$$

$$v = 2 \text{ m} \cdot \text{s}^{-1}$$

End of chapter exercises:

1. A wave travels along a string at a speed of $1,5 \text{ m} \cdot \text{s}^{-1}$. If the frequency of the source of the wave is 7,5 Hz, calculate:

- a) the wavelength of the wave
- b) the period of the wave

Solution:

a)

$$v = \lambda \cdot f$$

$$\lambda = \frac{v}{f}$$

$$\lambda = \frac{1,5}{7,5}$$

$$\lambda = 0,2 \text{ m}$$

b)

$$T = \frac{1}{f}$$

$$T = \frac{1}{7,5}$$

$$T = 1,33 \text{ s}$$

2. Water waves crash against a seawall around the harbour. Eight waves hit the seawall in 5 s. The distance between successive troughs is 9 m. The height of the waveform trough to crest is 1,5 m.

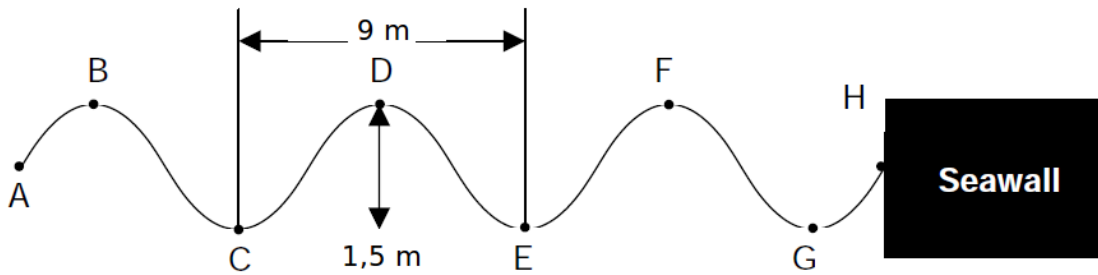

- a) How many complete waves are indicated in the sketch?
- b) Write down the letters that indicate any TWO points that are:
- in phase
 - out of phase
 - Represent ONE wavelength.
- c) Calculate the amplitude of the wave.
- d) Show that the period of the wave is 0,625 s.
- e) Calculate the frequency of the waves.
- f) Calculate the velocity of the waves.

Solution:

a) Three complete waves are shown.

b

i) Any one of the following pairs of points: BD, BF, DF, CE, CG, EG, AH

ii) Any one of the following pairs of points: AB, AC, AD, AE, AF, AG, BC, BE, BG, BH, CD, CF, CH, DE, DG, DH, EF, EH, FG, FH, GH

iii) Any one of the following pairs of points: BD, DF, CE or EG

c) 0,75 m (We are given the height, the amplitude is half the height)

d) 8 waves in 5 s

$$1 \text{ wave in } \frac{5}{8} \text{ s} = 0,625 \text{ s}$$

e) $f = \frac{1}{T} = \frac{1}{0,625} = 1,60 \text{ Hz}$

f) $v = \frac{s}{t} = \frac{9}{0,625} = 14,4 \text{ m} \cdot \text{s}^{-1}$

Chapter 9. Longitudinal waves

End of chapter exercises:

1. Which of the following is not a longitudinal wave?

- a) light
- b) sound
- c) ultrasound

Solution:

- a) light

2. Which of the following media can a longitudinal wave like sound not travel through?

- a) solid
- b) liquid
- c) gas
- d) vacuum

Solution:

- d) vacuum

3. A longitudinal wave has a compression to compression distance of 10 m. It takes the wave 5 s to pass a point.

- a) What is the wavelength of the longitudinal wave?
- b) What is the speed of the wave?

Solution:

- a) 10 m

b) $v = \frac{\lambda}{T} = \frac{10}{5} = 2 \text{ m}\cdot\text{s}^{-1}$

4. A flute produces a musical sound travelling at a speed of $320 \text{ m}\cdot\text{s}^{-1}$. The frequency of the note is 256 Hz. Calculate:

- a) the period of the note
- b) the wavelength of the note

Solution:

a) $T = \frac{1}{f} = \frac{1}{256} \text{ s}$

b) $\lambda = \frac{v}{f} = \frac{320}{256} = 1,25 \text{ m}$

Chapter 10. Sound

Exercise 10-1:

Study the following diagram representing a musical note.

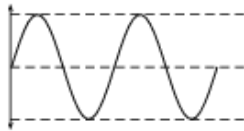

Redraw the diagram for a note

1. with a higher pitch
2. that is louder
3. that is softer

Solution:

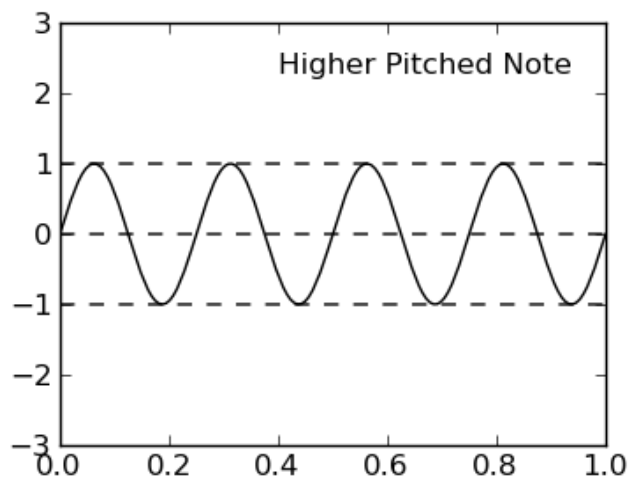

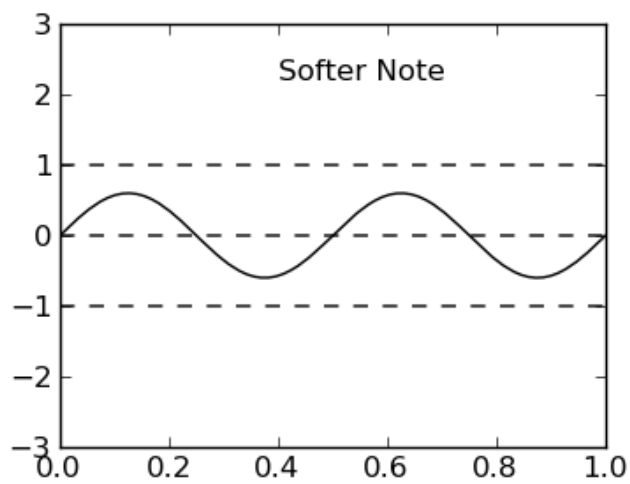
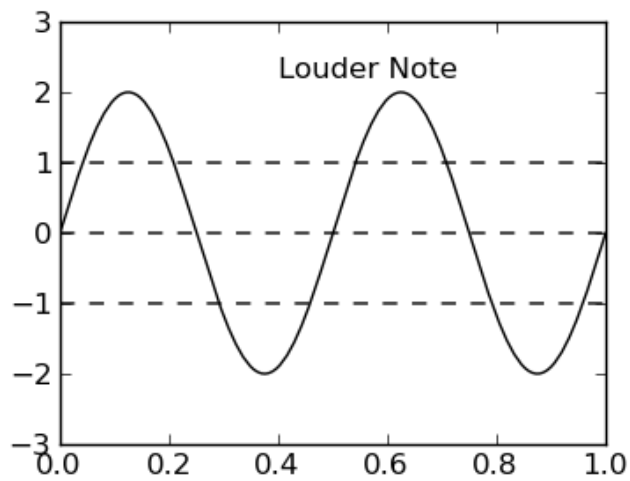

End of chapter exercises:

1. Choose a word from column B that best describes the concept in column A.

Column A	Column B
a) pitch of sound	amplitude
b) loudness of sound	frequency
c) quality of sound	speed
	waveform

Solution:

- a) Pitch of Sound: Frequency
- b) loudness of sound: Amplitude
- c) quality of sound: waveform

2. A tuning fork, a violin string and a loudspeaker are producing sounds. This is because they are all in a state of:

- a) compression
- b) rarefaction
- c) rotation
- d) tension
- e) vibration

Solution:

- e) vibration

3. What would a drummer do to make the sound of a drum give a note of lower pitch?

- a) hit the drum harder
- b) hit the drum less hard
- c) hit the drum near the edge
- d) loosen the drum skin
- e) tighten the drum skin

Solution:

- d) loosen the drum skin

4. What is the approximate range of audible frequencies for a healthy human?

- a) 0.2 Hz → 200 Hz
- b) 2 Hz → 2 000 Hz
- c) 20 Hz → 20 000 Hz
- d) 2 000 Hz → 2 000 000 Hz
- e) 200 Hz → 200 000 Hz

Solution:

- c) 20 Hz → 20 000 Hz

5. X and Y are different wave motions. In air, X travels much faster than Y but has a much

shorter wavelength. Which types of wave motion could X and Y be?

	X	Y
1	microwaves	red light
2	radio	infrared
3	red light	sound
4	sound	ultraviolet
5	ultraviolet	radio

Solution:

3) red light, sound

6. Astronauts are in a spaceship orbiting the moon. They see an explosion on the surface of the moon. Why can they not hear the explosion?

- a) explosions do not occur in space
- b) sound cannot travel through a vacuum
- c) sound travels too quickly in space to affect the ear drum
- d) the spaceship would be moving at a supersonic speed
- e) sound is reflected away from the spaceship

Solution:

b) sound cannot travel through a vacuum

7. A man stands between two cliffs as shown in the diagram and claps his hands once.

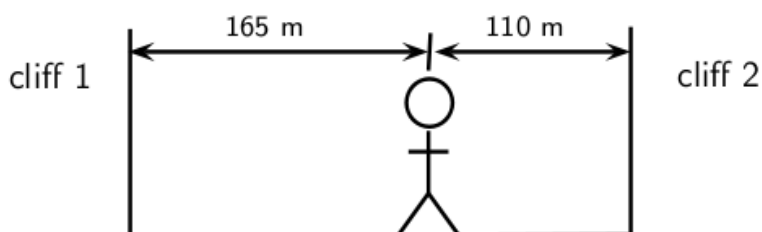

Assuming that the velocity of sound is $330 \text{ m}\cdot\text{s}^{-1}$, what will be the time interval between the two loudest echoes?

- a) $\frac{1}{6} \text{ s}$

- b) $\frac{5}{6}$ s
- c) $\frac{2}{3}$ s
- d) 1 s
- e) $\frac{1}{3}$ s

Solution:

- e) $\frac{1}{3}$ s

8. A dolphin emits an ultrasonic wave with frequency of 0,15 MHz. The speed of the ultrasonic wave in water is $1\,500\text{ m}\cdot\text{s}^{-1}$. What is the wavelength of this wave in water?

- a) 0,1 mm
- b) 1 cm
- c) 10 cm
- d) 100 m
- e) 10 m

Solution:

- c) 10 cm

9. The amplitude and frequency of a sound wave are both increased. How are the loudness and pitch of the sound affected?

	Loudness	Pitch
A	increased	raised
B	increased	unchanged
C	increased	lowered
D	decreased	raised
E	decreased	lowered

Solution:

- a. Increased & raised

10. A jet fighter travels slower than the speed of sound. Its speed is said to be:

- a) Mach 1
- b) supersonic
- c) subsonic
- d) hypersonic
- e) infrasonic

Solution:

- c) subsonic

11. A sound wave is different from a light wave in that a sound wave is:

- a) produced by a vibrating object and a light wave is not.
- b) not capable of travelling through a vacuum.
- c) capable of existing with a variety of frequencies and a light wave has a single frequency.
- d) not capable of diffracting and a light wave is.

Solution:

- b) not capable of travelling through a vacuum.

12. At the same temperature, sound waves have the fastest speed in:

- a) rock
- b) oxygen
- c) sand
- d) milk

Solution:

- a) rock

13. Two sound waves are travelling through a container of nitrogen gas. The first wave has a wavelength of 1,5 m, while the second wave has a wavelength of 4,5 m. The velocity of the second wave must be:

- a) $\frac{1}{9}$ the velocity of the first wave.
- b) $\frac{1}{3}$ the velocity of the first wave.
- c) the same as the velocity of the first wave.
- d) nine times larger than the velocity of the first wave.
- e) three times larger than the velocity of the first wave.

Solution:

c) the same as the velocity of the first wave.

14. A lightning storm creates both lightning and thunder. You see the lightning almost immediately since light travels at $3 \times 10^8 \text{ m} \cdot \text{s}^{-1}$. After seeing the lightning, you count 5 s and then you hear the thunder. Calculate the distance to the location of the storm.

Solution:

Assuming the speed of sound is $340 \text{ m} \cdot \text{s}^{-1}$,

$$D = v \times t$$

$$D = 340 \times 5$$

$$D = 1\,700 \text{ m}$$

15. A person is yelling from a second story window to another person standing at the garden gate, 50 m away. If the speed of sound is $344 \text{ m} \cdot \text{s}^{-1}$, how long does it take the sound to reach the person standing at the gate?

Solution:

$$t = \frac{D}{v} = \frac{50}{344} = 0,15 \text{ s}$$

16. Person 1 speaks to person 2. Explain how the sound is created by person 1 and how it is possible for person 2 to hear the conversation.

Solution:

When person 1 speaks, their vocal chords vibrate, creating identical vibrations in the air. These vibrations, or sound waves, travel through the air and reach person 2. The vibrations in the air causes person 2's eardrums to vibrate and therefore person 2 will hear them.

17. Sound cannot travel in space. Discuss what other modes of communication astronauts can use when they are outside the space shuttle?

Solution:

Sound cannot travel in a vacuum. Astronauts may use any other mode of communication that may operate in a vacuum. One method is the use of radios. Radios use electromagnetic waves to send and receive signals and these are able to propagate in a

vacuum. If the astronauts' radios fail, they are able to communicate using hand signals.

18. An automatic focus camera uses an ultrasonic sound wave to focus on objects. The camera sends out sound waves which are reflected off distant objects and return to the camera. A sensor detects the time it takes for the waves to return and then determines the distance an object is from the camera. If a sound wave (speed = $344 \text{ m} \cdot \text{s}^{-1}$) returns to the camera 0,150 s after leaving the camera, how far away is the object?

Solution:

The sound wave travels to the object and back to the camera in 0.15 seconds. Therefore, the distance to the object is:

$$\begin{aligned} D &= v \times t \\ &= 344 \times \left(\frac{0,15}{2} \right) \\ &= 25,8 \text{ m} \end{aligned}$$

19. Calculate the frequency (in Hz) and wavelength of the annoying sound made by a mosquito when it beats its wings at the average rate of 600 wing beats per second. Assume the speed of the sound waves is $344 \text{ m} \cdot \text{s}^{-1}$.

Solution:

Wavelength:

$$\lambda = \frac{v}{f} = \frac{344}{600} = 0,57 \text{ m}$$

Frequency:

It beats its wings 600 times per second, therefore the frequency of the sound is 600 Hz.

20. How does halving the frequency of a wave source affect the speed of the waves?

Solution:

The frequency and velocity is independent in homogeneous mediums. Therefore, halving the frequency will not affect the speed of the waves, but it will increase their wavelengths by a factor of 2.

21. Humans can detect frequencies as high as 20 000 Hz. Assuming the speed of sound in air is $344 \text{ m} \cdot \text{s}^{-1}$, calculate the wavelength of the sound corresponding to the upper range of audible hearing.

Solution:

$$\begin{aligned}\lambda &= \frac{v}{f} \\ &= \frac{344}{20\,000} \\ &= 0,017 \text{ m} \\ &= 17 \text{ mm}\end{aligned}$$

22. An elephant trumpets at 10 Hz. Assuming the speed of sound in air is $344 \text{ m} \cdot \text{s}^{-1}$, calculate the wavelength of this infrasonic sound wave made by the elephant.

Solution:

$$\lambda = \frac{v}{f} = \frac{344}{10} = 34,4 \text{ m}$$

23. A ship sends a signal out to determine the depth of the ocean. The signal returns 2,5 seconds later. If sound travels at $1450 \text{ m} \cdot \text{s}^{-1}$ in sea water, how deep is the ocean at that point?

Solution:

The sound wave travels to the bottom and back to the ship in 2.5 seconds. Therefore, the distance to the bottom is:

$$\begin{aligned}D &= v \times t \\ &= 1450 \times \left(\frac{2,5}{2}\right) \\ &= 1812,5 \text{ m}\end{aligned}$$

24. A person shouts at a cliff and hears an echo from the cliff 1 s later. If the speed of sound is $344 \text{ m} \cdot \text{s}^{-1}$, how far away is the cliff?

Solution:

$$\begin{aligned}D_{\text{total}} &= v \times t \\ D_{\text{total}} &= 344 \times 1 \\ D_{\text{total}} &= 344 \text{ m} \\ D_{\text{cliff}} &= \frac{D_{\text{total}}}{2} \\ D_{\text{cliff}} &= \frac{344}{2} \\ D_{\text{cliff}} &= 172 \text{ m}\end{aligned}$$

25. Select a word from Column B that best fits the description in Column A:

Column A	Column B
1. waves in the air caused by vibrations	A. longitudinal waves
2. waves that move in one direction, but medium moves in another	B. frequency
3. waves and medium that move in the same direction	C. period
4. the distance between consecutive points of a wave which are in phase	D. amplitude
5. how often a single wavelength goes by	E. sound waves
6. half the difference between high points and low points of waves	F. standing waves
7. the distance a wave covers per time interval	G. transverse waves
8. the time taken for one wavelength to pass a point	H. wavelength
	I. music
	J. sounds
	K. wave speed

Solution

1. waves in the air caused by vibrations: sound waves
2. waves that move in one direction, but medium moves in another: transverse waves
3. waves and medium that move in the same direction: longitudinal waves
4. the distance between consecutive points of a wave which are in phase: wavelength
5. how often a single wavelength goes by: frequency
6. half the difference between high points and low points of waves: amplitude
7. the distance a wave covers per time interval: wave speed
8. the time taken for one wavelength to pass a point: period

Chapter 11. Electromagnetic radiation

Exercise 11-1:

1. Arrange the following types of EM radiation in order of increasing frequency: infrared, X-rays, ultraviolet, visible, gamma.

Solution:

Infrared, visible, ultra-violet, X-rays, gamma

2. Calculate the frequency of an EM wave with a wavelength of 400 nm.

Solution:

$$\lambda = \frac{c}{f}$$
$$f = \frac{c}{\lambda}$$
$$f = \frac{3 \times 10^8}{400 \times 10^{-9}}$$
$$f = 7,5 \times 10^{14} \text{ Hz}$$

3. Give an example of the use of each type of EM radiation, i.e. gamma rays, X-rays, ultraviolet light, visible light, infrared, microwave and radio and TV waves.

Solution:

Gamma rays: Studying the physics of stars by observing gamma ray bursts in space

X-rays: Searching baggage at the airport

Ultra-violet: Used in sun beds to help people get a tan during winter. NB! Dangerous!

Visible light: Used in Light Emitting Diodes for use as indicator lights in electronic equipment

Infrared: Used for night-vision goggles, objects emit infrared radiation because they are warm and can therefore be detected at night using infrared goggles.

Microwaves: Microwave ovens emit microwave radiation that excites motion in water molecules in foodstuffs, thereby warming it up

radio waves: Use for telecommunication

TV waves: see radio waves.

Exercise 11-2:

1. Indicate the penetrating ability of the different kinds of EM radiation and relate it to energy of the radiation.

Solution:

Usually, radiation with higher energy levels (higher frequency <> shorter wavelengths) have greater penetrating ability than radiation with lower energy.

2. Describe the dangers of gamma rays, X-rays and the damaging effect of ultra-violet radiation on skin.

Solution:

Gamma rays have very high energy levels and can interact with genetic material in biological tissue.

Prolonged exposure to X-rays can damage living tissue and may cause cancer.

Ultra-violet radiation is absorbed by the skin and is damaging on skin cells. This is why we should wear sunscreen when we are going to be in the sun for extended periods.

Exercise 11-3:

1. How is the energy of a photon related to its frequency and wavelength?

Solution:

The energy of a photon is directly proportional to its frequency and indirectly proportional to its wavelength. We can show this as: $E = hf = \frac{hc}{\lambda}$, where h is Planck's constant.

2. Calculate the energy of a photon of EM radiation with a frequency of 10^{12} Hz

Solution:

$$E = hf$$
$$E = (6,6 \times 10^{-34})(10^{12})$$
$$E = 6,6 \times 10^{-22} \text{ J}$$

3. Determine the energy of a photon of EM radiation with a wavelength of 600 nm.

Solution:

$$E = \frac{hc}{\lambda}$$
$$E = \frac{(6,6 \times 10^{-34})(3 \times 10^8)}{600 \times 10^{-9}}$$
$$E = 3,3 \times 10^{-19} \text{ J}$$

End of chapter exercises:

1. What is the energy of a photon of EM radiation with a frequency of 3×10^8 Hz ?

Solution:

$$E = hf$$
$$E = (6,6 \times 10^{-34})(3 \times 10^8)$$
$$E = 2,0 \times 10^{-25}$$

2. What is the energy of a photon of light with a wavelength of 660 nm?

Solution:

$$E = \frac{hc}{\lambda}$$
$$E = \frac{(6,6 \times 10^{-34})(3 \times 10^8)}{660 \times 10^{-9}}$$
$$E = 3 \times 10^{-19}$$

3. What is the energy of a photon of light with a frequency of 13THz?

Solution:

$$\begin{aligned}f &= 13 \text{ THz} \\ &= 13 \times 10^{12} \text{ Hz} \\ E &= hf \\ &= (6,6 \times 10^{-34}) \times (13 \times 10^{12}) \\ &= 8,6 \times 10^{-21} \text{ J}\end{aligned}$$

4. What is the wavelength of a photon of light with a frequency of 101,3 kHz?

Solution:

$$\begin{aligned}c &= f \lambda \\ \lambda &= \frac{c}{f} \\ &= \frac{3 \times 10^8}{101,3 \times 10^3} \\ &= 3,0 \times 10^3 \text{ m}\end{aligned}$$

5. What is the energy of a photon of light with a wavelength of 532 nm and one with a frequency of 13GHz, and which has the longer wavelength?

Solution:

$$\begin{aligned}\lambda &= 532 \text{ nm} \\ E &= hf \\ &= \frac{hc}{\lambda} \\ &= \frac{(6,6 \times 10^{-34})(3 \times 10^8)}{532 \times 10^{-9}} \\ &= 3,7 \times 10^{-19} \text{ J}\end{aligned}$$
$$\begin{aligned}f &= 13 \text{ GHz} \\ E &= hf \\ &= (6,6 \times 10^{-34}) \times (13 \times 10^9) \\ &= 8,6 \times 10^{-24} \text{ J} \\ \lambda &= \frac{c}{f} \\ &= \frac{3 \times 10^8}{13 \times 10^9} \\ &= 2,3 \times 10^{-2} \text{ m}\end{aligned}$$

13 GHz light has a longer wavelength.

6. List the main types of electromagnetic radiation in order of increasing wavelength.

Solution:

Radio, microwave, infrared, visible, ultraviolet, X-ray, gamma ray

7. List the main uses of:

- a) radio waves
- b) infrared
- c) gamma rays
- d) X-rays

Solution:

- a) radio waves: radio, television broadcasts
- b) infrared: night vision, heat sensors, laser metal cutting
- c) Gamma rays: used to kill the bacteria in marshmallows and to sterilise medical equipment
- d) X-rays: used to image bone structures

8. Explain why we need to protect ourselves from ultraviolet radiation from the Sun.

Solution:

Answers should include mention of:

UVA and UVB can damage collagen fibres which results in the speeding up skin ageing. In general, UVA penetrates deeply and does not cause sunburn. UVB light can cause skin cancer.

9. List some advantages and disadvantages of using X-rays.

Solution:

Advantages: It can be used to look inside humans, to look at broken bones, look for tumours etc.

Disadvantages: Prolonged exposure to x-rays can lead to cell damage and cancer.

10. What precautions should we take when using cell phones?

Solution

Use hands-free to decrease the radiation to the head. Keep the mobile phone away from the body. Do not telephone in a car without an external antenna.

11. Write a short essay on a type of electromagnetic waves. You should look at uses, advantages and disadvantages of your chosen radiation.

Solution:

Infrared radiation is radiation that has a wavelength of approximately 700 nm to 3000 nm. Thermal radiation falls within this range and is emitted by most objects at room temperature. Infrared radiation can be used to study stars which are cooler than our sun, known as red dwarfs. These stars have temperatures of approximately 2800K and emit most of their light in the infrared region of the EM spectrum. The advantage of using infrared radiation for studying stars is the fact that infrared radiation can penetrate interstellar dust that occurs in space so we can study objects that would not be visible if we used visible light to study them. A disadvantage of using infrared radiation for astronomical purposes is the fact that water vapour strongly absorbs infrared radiation and the sky is practically opaque in certain wavelength bands that falls within the infrared region.

12. Explain why some types of electromagnetic radiation are more penetrating than others.

Solution:

Usually, radiation with higher energy levels (higher frequency - shorter wavelengths) have greater penetrating ability than radiation with lower energy. This makes the higher frequency radiation (ultraviolet, x-ray and gamma ray) radiation more penetrating than the lower frequency radiation (microwaves, radio waves, infrared)

Chapter 12. The particles that substances are made of

End of chapter exercises:

1. Give one word or term for each of the following descriptions.

- a) A composition of two or more atoms that act as a unit.
- b) Chemical formula that gives the relative number of atoms of each element that are in a molecule.

Solution:

- a) Molecule
- b) Empirical formula

2. Give a definition for each of the following terms:

- a) Molecule
- b) Ionic compound
- c) Covalent network structure
- d) Empirical formula
- e) Ball-and-stick model

Solution:

- a) A group of two or more atoms that are attracted to each other by chemical bonds
- b) An ionic compound is an ionically bonded substance. Ionic compounds have ionic bonds and consist of a metal and a non-metal.
- c) A giant lattice of covalently bonded molecules such as graphite.
- d) A formula giving the relative number of atoms of each element in a molecule.
- e) A means of representing a molecule graphically. Elements are shown as balls and the bonds between them are represented by lines or 'sticks'.

3. Ammonia, an ingredient in household cleaners, is made up of one part nitrogen (N) and three parts hydrogen (H). Answer the following questions:

- a) is ammonia a covalent, ionic or metallic substance?
- b) write down the molecular formula for ammonia
- c) draw a ball-and-stick diagram

d) draw a space-filling diagram

Solution:

a) covalent

b) NH_3

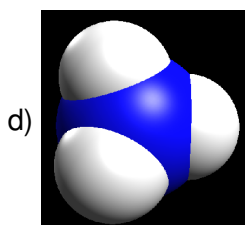
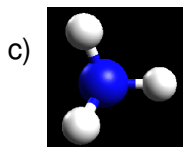

4. In each of the following, say whether the chemical substance is made up of covalent, molecular structures, covalent network structures, ionic network structures or metallic structures:

a) ammonia gas (NH_3)

b) zinc metal (Zn)

c) graphite (C)

d) nitric acid (HNO_3)

e) potassium bromide (KBr)

Solution:

a) covalent molecular structure

b) metallic network structure

c) covalent network structure

d) covalent molecular structure

e) ionic network structure

5. Refer to the diagram below and then answer the questions that follow:

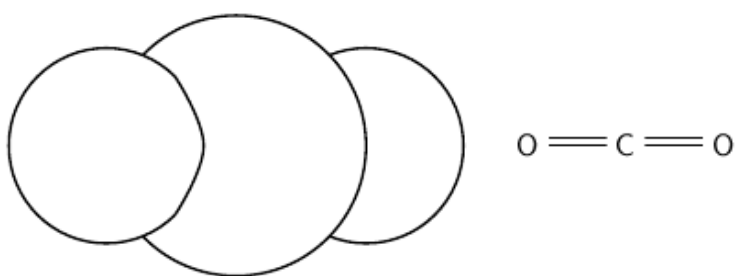

- Identify the molecule.
- Write the molecular formula for the molecule.
- Is the molecule a covalent, ionic or metallic substance? Explain.

Solution:

- Carbon dioxide. (There is one carbon and two oxygen atoms.)
- CO_2
- Covalent substance. The electronegativity difference between C and O is 0.89 so the C and O are covalently bonded.

6. Represent each of the following molecules using its chemical formula, its structural formula and the ball-and-stick model:

- nitrogen
- carbon dioxide
- methane
- argon

Solution:

a) Chemical formula: N_2

structural formula:



ball-and-stick model:

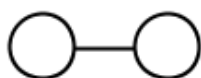

b) Chemical formula: CO_2

structural formula:

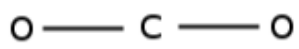

ball-and-stick model:



c) Chemical formula: CH_4

structural formula:

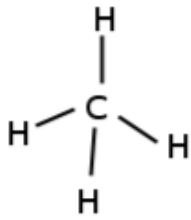

ball-and-stick model:

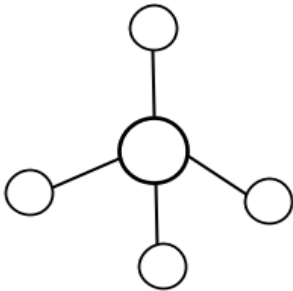

d) Chemical formula: Ar

structural formula:

Ar

ball-and-stick model:



Chapter 13. Physical and chemical change

Exercise 13-1:

For each of the following say whether a chemical or a physical change occurs.

1. Melting candle wax.
2. Mixing sodium chloride (NaCl) and silver nitrate (AgNO_3) to form silver chloride (AgCl).
3. Mixing hydrochloric acid (HCl) and magnesium ribbon (Mg) to form magnesium chloride (MgCl_2).
4. Dissolving salt in water.
5. Tearing a piece of magnesium ribbon.

Solution:

1. Physical change
2. Chemical change
3. Chemical change
4. Physical change
5. Physical change

Exercise 13-2:

Complete the following chemical reactions to show that atoms and mass are conserved. Give the total molecular mass of the reactants and the products.

1. Hydrogen gas combines with nitrogen gas to form ammonia.

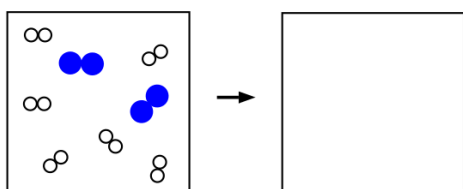

2. Hydrogen peroxide decomposes (breaks down) to form hydrogen and oxygen.

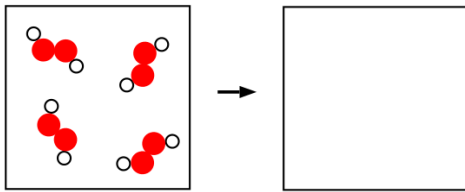

3. Calcium and oxygen gas react to form calcium oxide.

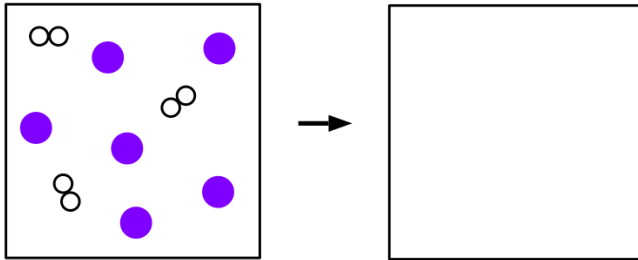

Solution :

1. The molecular mass of the reactants is:

$$6(2(1,01)) + 2(2(14,0)) = 68,12$$

The molecular mass of the products is:

$$4(3(1,01) + 14,0) = 4(17,03) = 68,12$$

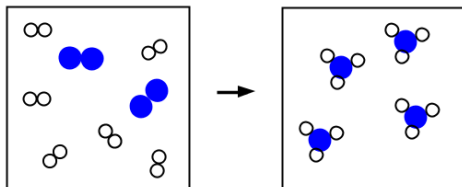

2. The molecular mass of the reactants is:

$$4(2(1,01)) + 2(16,0) = 136,08$$

The molecular mass of the products is:

$$4(2(1,01)) + 4(2(16,0)) = 136,08$$

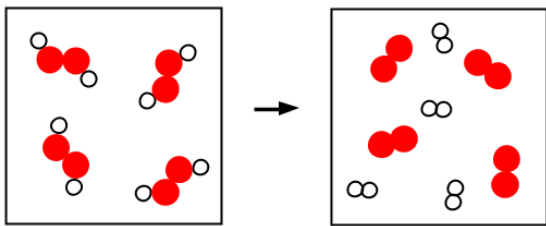

3.

Total mass of the reactants:

$$3(2(1,01)) + 6(40,1) = 246,66$$

Total mass of the products:

$$6(1,01 + 40,1) = 246,66$$

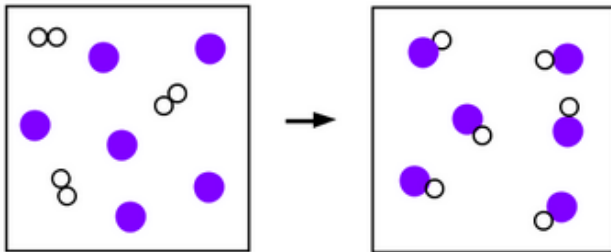

End of chapter exercises:

1. For each of the following definitions give one word or term:

- A change that can be seen or felt, where the particles involved are not broken up in any way
- The formation of new substances in a chemical reaction
- A reaction where a new product is formed from elements or smaller compounds

Solution:

- Physical change
- Chemical change
- Synthesis reaction

2. Explain how a chemical change differs from a physical change.

Solution:

In a physical change the particles may rearrange themselves but do not break up. A chemical change involves the breaking up of some particles and the formation of new particles. Physical changes have very small energy changes while chemical changes have very large energy changes. Chemical changes are more difficult to reverse compared to physical changes.

3. Complete the following table by saying whether each of the descriptions is an example of a physical or chemical change:

Description	Physical or chemical
Hot and cold water mix together	
Milk turns sour	
A car starts to rust	
Food digests in the stomach	
Alcohol disappears when it is placed on your skin	
Warming food in a microwave	
Separating sand and gravel	
Fireworks exploding	

Solution:

Description	Physical or chemical
Hot and cold water mix together	Physical
Milk turns sour	Chemical
A car starts to rust	Chemical
Food digests in the stomach	Chemical
Alcohol disappears when it is placed on your skin	Physical
Warming food in a microwave	Physical
Separating sand and gravel	Physical
Fireworks exploding	Chemical

4. For each of the following reactions, say whether it is an example of a synthesis or decomposition reaction:

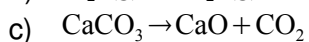
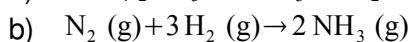
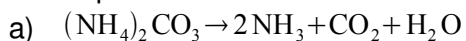

Solution:

a) Decomposition

b) Synthesis

c) Decomposition

5. For the following equation: $\text{CaCO}_3 (\text{s}) \rightarrow \text{CaO} + \text{CO}_2$ show that the law of conservation of mass applies. Draw sub-microscopic diagrams to represent this reaction.

Solution

Left hand side of the equation

$$\text{Total atomic mass} = (1 \times 40) + (1 \times 12) + (3 \times 16) = 100 \text{ u}$$

Right hand side of the equation

$$\text{Total atomic mass} = (1 \times 12) + (2 \times 16) + (1 \times 40) + (1 \times 16) = 100 \text{ u}$$

Using submicroscopic diagrams we get:

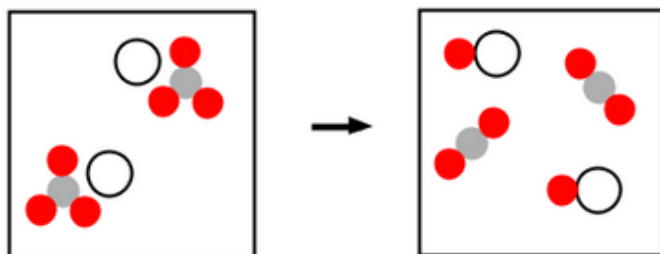

Note that calcium carbonate is an ionic substance and so the representation here is a simplified form of the crystal lattice structure. The calcium ion is ionically bonded to the carbonate ion.

Chapter 14. Representing chemical change

Exercise 14-1:

1. Write down the chemical formula for each of the following compounds:

- a) iron (III) chloride
- b) zinc nitrate
- c) aluminium sulphate
- d) calcium hydroxide
- e) magnesium carbonate
- f) the product when carbon reacts with oxygen
- g) the product when hydrogen reacts with nitrogen
- h) potassium oxide
- i) copper (II) bromide
- j) potassium dichromate

Solution:

- a) FeCl_3
- b) $\text{Zn}(\text{NO}_3)_2$
- c) $\text{Al}_2(\text{SO}_4)_3$
- d) $\text{Ca}(\text{OH})_2$
- e) MgCO_3
- f) CO_2
- g) NH_3
- h) K_2O
- i) CuBr_2
- j) $\text{K}_2\text{Cr}_2\text{O}_7$

2. Write down the name for each of the following compounds:

- a) SO_2
- b) KMnO_4
- c) $(\text{NH}_4)_2\text{SO}_4$
- d) BaF_2
- e) $\text{Cr}(\text{HSO}_4)_3$
- f) CH_4

Solution:

- a) sulphur dioxide
- b) potassium permanganate
- c) ammonium sulphate
- d) barium fluoride
- e) chromium (III) hydrogen sulphate
- f) methane (carbon tetrahydride)

Exercise 14-2:

1. Balance the following equation:

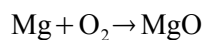

Solution:

If we count the number of atoms of each element in the reactants and products we find:

Reactants: Mg=1, O=2

Products: Mg=1, O=1

So we add a co-efficient of 2 in front of the MgO and in front of the Mg:

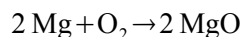

The equation is now balanced.

2. Balance the following equation:

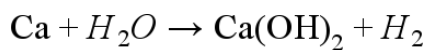

Solution:

If we count the number of atoms of each element in the reactants and products we find:

Reactants: Ca=1, H=2, O=1

Products: Ca=1, H=4, O=2

In order to balance the number of H and O atoms, we change the coefficient of H_2O to 2.

Now:

Reactants: Ca=1, H=4, O=2

Products: Ca=1, H=4, O=2

Balanced equation: $Ca + 2H_2O \rightarrow Ca(OH)_2 + H_2$

3. Balance the following equation:

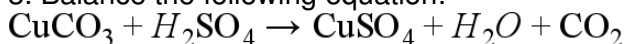

Solution:

If we count the number of atoms of each element in the reactants and products we find:

Reactants: Cu=1, C=1, O=7, H=2, S=1

Products: Cu=1, C=1, O=7, H=2, S=1

The number of atoms per element in products = number of atoms per element in reactants, the equation is already balanced:

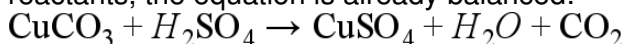

4. Balance the following equation:

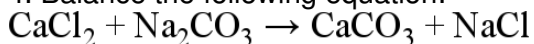

Solution:

If we count the number of atoms of each element in the reactants and products we find:

Reactants: Ca=1, Cl=2, Na=2, C=1, O=3

Products: Ca=1, Cl=1, Na=1, C=1, O=3

In order to balance the number of Cl and Na atoms, we change the coefficient of $NaCl$ to

2. Now:

Reactants: Ca=1, Cl=2, Na=2, C=1, O=3

Products: Ca=1, Cl=2, Na=2, C=1, O=3

Balanced equation: $CaCl_2 + Na_2CO_3 \rightarrow CaCO_3 + 2NaCl$

5. Balance the following equation:

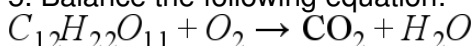

Solution:

If we count the number of atoms of each element in the reactants and products we find:

Reactants: C=12, H=22, O=13

Products: C=1, H=2, O=3

In order to balance the number of C atoms, we change the coefficient of CO_2 to 12. Now:

Reactants: C=12, H=22, O=13

Products: C=12, H=2, O=25

To balance the H atoms, we change the coefficient of H_2O to 11:

Reactants: C=12, H=22, O=13

Products: C=12, H=22, O=35

To balance the O atoms, we change the coefficient of O_2 to 12:

Reactants: C=12, H=22, O=35

Products: C=12, H=22, O=35

Balanced equation: $\text{C}_{12}\text{H}_{22}\text{O}_{11} + 12\text{O}_2 \rightarrow 12\text{CO}_2 + 11\text{H}_2\text{O}$

6. Barium chloride reacts with sulphuric acid to produce barium sulphate and hydrochloric acid.

Solution:

First write the equation for the reaction:

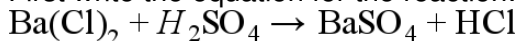

If we count the number of atoms of each element in the reactants and products we find:

Reactants: Ba=1, Cl=2, H=2, S=1, O=4

Products: Ba=1, Cl=1, H=1, S=1, O=4

In order to balance the number of H and Cl atoms, we change the coefficient of HCl to 2.

Now:

Reactants: Ba=1, Cl=2, H=2, S=1, O=4

Products: Ba=1, Cl=2, H=2, S=1, O=4

Balanced equation: $\text{Ba}(\text{Cl})_2 + \text{H}_2\text{SO}_4 \rightarrow \text{BaSO}_4 + 2\text{HCl}$

7. Ethane (C_2H_6) reacts with oxygen to form carbon dioxide and steam.

Solution:

First write the equation for the reaction:

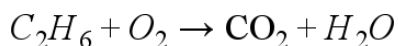

If we count the number of atoms of each element in the reactants and products we find:

Reactants: C=2, H=6, O=2

Products: C=1, H=2, O=3

In order to balance the number of C atoms, we change the coefficient of CO_2 to 2. Now:

Reactants: C=2, H=6, O=2

Products: C=2, H=2, O=5

In order to balance the number of H atoms, we change the coefficient of H_2O to 3. Now:

Reactants: C=2, H=6, O=2

Products: C=2, H=6, O=7

In order to balance the number of O atoms, we change the coefficient of O_2 to 3.5 and then multiply all coefficients by 2 to get integers. Now:

Reactants: C=4, H=12, O=14

Products: C=4, H=12, O=14

Balanced equation: $2C_2H_6 + 7O_2 \rightarrow 4CO_2 + 6H_2O$

8. Ammonium carbonate is often used as a smelling salt. Balance the following reaction for the decomposition of ammonium carbonate:

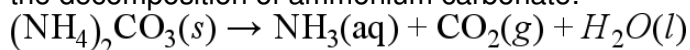

Solution:

If we count the number of atoms of each element in the reactants and products we find:

Reactants: N=2, H=8, C=1, O=3

Products: N=1, H=5, C=1, O=3

In order to balance the number of N atoms, we change the coefficient of NH_3 to 2. Now:

Reactants: N=2, H=8, C=1, O=3

Products: N=2, H=8, C=1, O=3

Balanced equation: $(NH_4)_2CO_3(s) \rightarrow 2NH_3(aq) + CO_2(g) + H_2O(l)$

9. Hydrogen fuel cells are extremely important in the development of alternative energy sources. Many of these cells work by reacting hydrogen and oxygen gases together to form water, a reaction which also produces electricity. Balance the following equation:

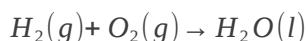

Solution

If we count the number of atoms of each element in the reactants and products we find:

Reactants: H=2, O=2

Products: H=2, O=1

In order to balance the number of O atoms, we change the coefficient of H_2O to 2.

Now:

Reactants: H=2, O=2

Products: H=4, O= 2

To balance the H atoms, we change the coefficient of H_2 to 2:

Reactants: H=4, O=2

Products: H=4, O=2

Balanced equation: $2H_2(g) + O_2(g) \rightarrow 2H_2O(l)$

10. The synthesis of ammonia (NH_3), made famous by the German chemist Fritz Haber in the early 20th century, is one of the most important reactions in the chemical industry. Balance the following equation used to produce ammonia:

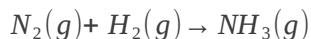

Solution

If we count the number of atoms of each element in the reactants and products we find:

Reactants: N=2, H=2

Products: N=1, H=3

In order to balance the number of N atoms, we change the coefficient of NH_3 to 2.

Now:

Reactants: N=2, H=2

Products: N=2, H=6

To balance the H atoms, we change the coefficient of H_2 to 3:

Reactants: N=2, H=6

Products: N=2, H=6

Balanced equation: $N_2(g) + 3H_2(g) \rightarrow 2NH_3(g)$

Exercise 14-3:

Write balanced equations for each of the following reactions, include state symbols:

1. Lead (II) nitrate solution reacts with a potassium iodide solution to form a precipitate (solid) of lead iodide while potassium nitrate remains in solution.

Solution

First we write an equation: $Pb(NO_3)_2(aq) + KI(aq) \rightarrow PbI_2(aq) + KNO_3(aq)$

If we count the number of atoms of each element in the reactants and products we find:

Reactants: Pb=1, O=6, K=1, N=2, I=1

Products: Pb=1, O=4, K=1, N=1, I=2

In order to balance the number of I atoms, we change the coefficient of KI to 2. And we also change the co-efficient of KNO_3 to 2. Now:

Reactants: Pb=1, O=6, K=2, N=2, I=2

Products: Pb=1, O=6, K=2, N=2, I=2

Balanced equation: $Pb(NO_3)_2(aq) + 2KI(aq) \rightarrow PbI_2(aq) + 2KNO_3(aq)$

2. When heated, aluminium metal reacts with solid copper oxide to produce copper metal and aluminium oxide (Al_2O_3).

Solution

First we write an equation: $Al(s) + CuO(s) \rightarrow Cu(s) + Al_2O_3(s)$

If we count the number of atoms of each element in the reactants and products we find:

Reactants: Al=1, O=1, Cu=1

Products: Al=2, O=3, Cu=1

In order to balance the number of O atoms, we change the coefficient of CuO to 3, we also change the coefficient of the Al to 2, and we change the coefficient of Cu to 3. Now:

Reactants: Al=2, O=3, Cu=3

Products: Al=2, O=3, Cu=3

Balanced equation: $2Al(s) + 3CuO(s) \rightarrow 3Cu(s) + Al_2O_3(s)$

3. When calcium chloride solution is mixed with silver nitrate solution, a white precipitate (solid) of silver chloride appears. Calcium nitrate ($Ca(NO_3)_2$) is also produced in the solution.

Solution

First we write an equation: $\text{CaCl}_2(\text{aq}) + \text{AgNO}_3(\text{aq}) \rightarrow \text{AgCl}(\text{s}) + \text{Ca}(\text{NO}_3)_2(\text{aq})$

If we count the number of atoms of each element in the reactants and products we find:

Reactants: Ca=1, Cl=2, Ag=1, N=1, O=3

Products: Ca=1, Cl=1, Ag=1, N=2, O=6

In order to balance the number of N atoms, we change the coefficient of AgNO_3 to 2, we also change the coefficient of AgCl to 2. Now:

Reactants: Ca=1, Cl=2, Ag=2, N=2, O=6

Products: Ca=1, Cl=2, Ag=2, N=2, O=6

Balanced equation: $\text{CaCl}_2(\text{aq}) + 2\text{AgNO}_3(\text{aq}) \rightarrow 2\text{AgCl}(\text{s}) + \text{Ca}(\text{NO}_3)_2(\text{aq})$

4. Solid ammonium carbonate decomposes to form three gaseous products.

Solution

We first identify the reactants and products:

Reactants: $(\text{NH}_4)_2\text{CO}_3$

Products: $\text{NH}_3, \text{CO}_2, \text{H}_2\text{O}$

The equation is:



We now count the number of atoms of each element in the reactant and product:

Reactants: N=2 H=8 C=1 O=3

Products: N=1 H=4 C=1 O=3

Both the N and the H are not balanced. So we add a 2 in front of the ammonia:



We now check the number of atoms of each element in the reactant and product:

Reactants: N=2 H=8 C=1 O=3

Products: N=2 H=8 C=1 O=3

The equation is balanced.

End of chapter exercises:

1. Propane is a fuel that is commonly used as a heat source for engines and homes. Balance the following equation for the combustion of propane:

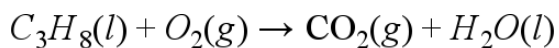

Solution:

If we count the number of atoms of each element in the reactants and products we find:

Reactants: C=3, H=8, O=2

Products: C=1, H=2, O=3

In order to balance the number of C atoms, we change the coefficient of CO_2 to 3, we also change the coefficient of H_2O to 4 and the coefficient of O_2 to 5. Now:

Reactants: C=3, H=8, O=10

Products: C=3, H=8, O=10

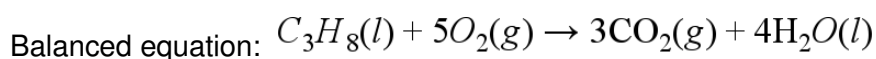

2. Methane (CH_4) burns in oxygen according to the following reaction.

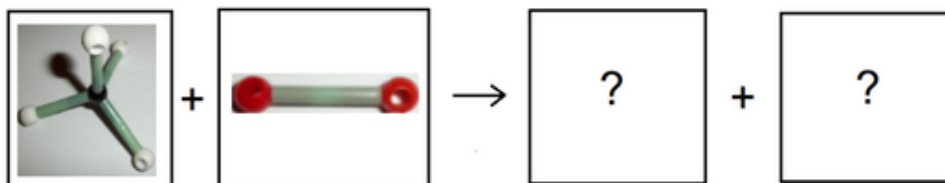

a. Complete the diagrams by drawing ball-and-stick models of the products.

b. Write a balanced chemical equation for the reaction and include state symbols.

Solution:

a.

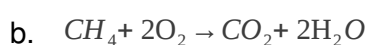
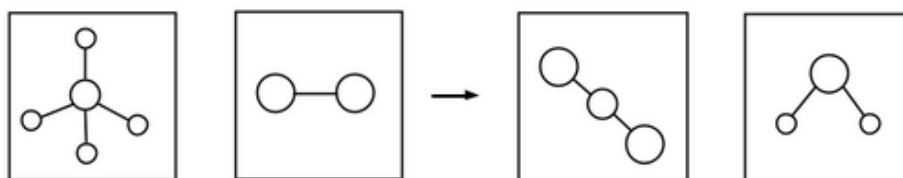

3. Chemical weapons were banned by the Geneva Protocol in 1925. According to this protocol, all chemicals that release suffocating and poisonous gases are not to be used as weapons. White phosphorus, a very reactive allotrope of phosphorus, was recently used during a military attack. Phosphorus burns vigorously in oxygen. Many people got severe burns and some died as a result. The equation for this spontaneous reaction is:

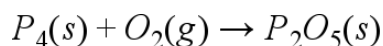

- Balance the chemical equation.
- Prove that the law of conservation of mass is obeyed during this chemical reaction.
- Name the product formed during this reaction.
- Classify the reaction as a synthesis or decomposition reaction. Give a reason for your answer.

Solution:

- If we count the number of atoms of each element in the reactants and products we find:

Reactants: P=4, O=2

Products: P=2, O=5

In order to balance the number of P atoms, we change the coefficient of P_2O_5 to 2, we also change the coefficient of O_2 to 5. Now:

Reactants: P=4, O=10

Products: P=4, O=10

Balanced equation: $P_4(s) + 5O_2(g) \rightarrow 2P_2O_5(s)$

- By looking at the balanced equation we can see that there are the same number of each kind of atom on both sides of the equation. Adding up the mass on the left hand side and comparing it to the mass on the right hand side gives the same number. So the law of conservation of mass is obeyed.

c) Phosphorus pentoxide

d) Synthesis. Two compounds combine to give a new compound.

4. The following diagrams represent the combustion of ethane (C_2H_6). Complete the diagrams and write a balanced equation for the reaction. Indicate the state symbols.

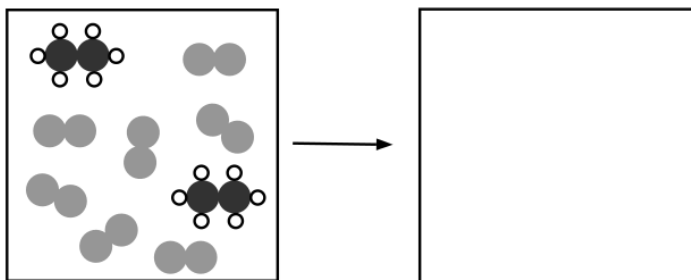

Solution:

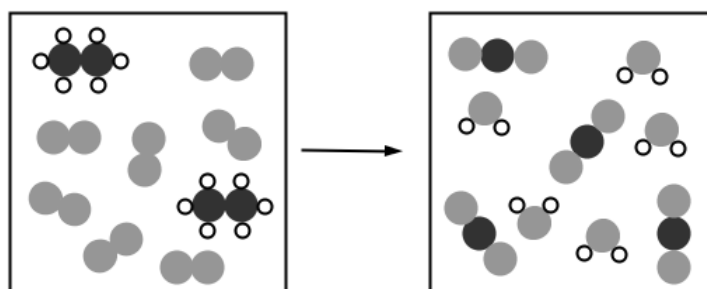

The balanced equation is:

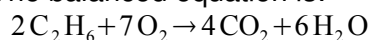

5. Balance the following chemical equation: $N_2O_5 \rightarrow NO_2 + O_2$. Draw submicroscopic diagrams to represent this reaction.

Solution:

Reactants: 2 N, 5 O

Products: 1 N, 4 O

So we add a 2 in front of the nitrogen dioxide: $N_2O_5 \rightarrow 2NO_2 + O_2$

Reactants: 2 N, 5 O

Products: 2 N, 6 O

So we add a 2 in front of the N_2O_5 : $2N_2O_5 \rightarrow 2NO_2 + O_2$

Reactants: 4 N, 10 O

Products: 2 N, 6 O

So we change the 2 to a 4 in front of the nitrogen dioxide: $2N_2O_5 \rightarrow 4NO_2 + O_2$

Reactants: 4 N, 10 O

Products: 4 N, 10 O

The equation is now balanced

6. Sulphur can be produced by the Claus process. This two-step process involves reacting hydrogen sulphide with oxygen and then reacting the sulphur dioxide that is produced with more hydrogen sulphide. The equations for these two reactions are:

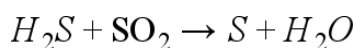
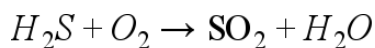

Balance these two equations.

Solution:

For the first equation: $H_2S + O_2 \rightarrow SO_2 + H_2O$

Reactants: 2 H, 1 S and 2 O

Products: 2 H, 1 S and 3 O

So we add a 2 in front of the O_2 : $H_2S + 2O_2 \rightarrow SO_2 + H_2O$

Now we have:

Reactants: 2 H, 1 S and 4 O

Products: 2 H, 1 S and 3 O

And so we must add a 2 in front of the H_2O : $H_2S + 2O_2 \rightarrow SO_2 + 2H_2O$

This gives:

Reactants: 2 H, 1 S and 4 O

Products: 4 H, 1 S and 4 O

Adding a 2 in front of the H_2S to balance the hydrogens gives:

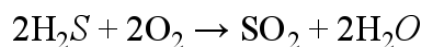

Reactants: 4 H, 2 S and 4 O

Products: 4 H, 1 S and 4 O

And now we add a 2 in front of the SO_2 : $2H_2S + 2O_2 \rightarrow 2SO_2 + 2H_2O$

Reactants: 4 H, 2 S and 4 O

Products: 4 H, 2 S and 6 O

Finally we change the 2 to a 3 in front of the oxygen: $2H_2S + 3O_2 \rightarrow 2SO_2 + 2H_2O$

The equation is now balanced.

For the second equation: $H_2S + SO_2 \rightarrow S + H_2O$

Reactants: 2 H, 2 S and 2 O

Products: 2 H, 1 S and 1 O

So we add a 2 in front of the water: $H_2S + SO_2 \rightarrow S + 2H_2O$

Reactants: 2 H, 2 S and 2 O

Products: 4 H, 1 S and 2 O

So we add a 2 in front of the hydrogen sulphide: $2H_2S + SO_2 \rightarrow S + 2H_2O$

Reactants: 4 H, 3 S and 2 O

Products: 4 H, 1 S and 2 O

And finally we add a 3 in front of the sulphur: $2H_2S + SO_2 \rightarrow 3S + 2H_2O$

The equation is now balanced.

7. Aspartame, an artificial sweetener, has the formula $C_{14}H_{18}N_2O_5$. Write the balanced equation for its combustion (reaction with O_2) to form $CO_2(g)$, liquid H_2O , and N_2 gas.

Solution:

First we write an equation: $C_{14}H_{18}N_2O_5(s) + O_2(g) \rightarrow H_2O(l) + CO_2(g) + N_2(g)$

If we count the number of atoms of each element in the reactants and products we find:

Reactants: C=14, H=18, N=2, O=7

Products: C=1, H=2, N=2, O=3

In order to balance the number of C atoms, we change the coefficient of CO_2 to 14, we also change the coefficient of H_2O to 9 and the coefficient of O_2 to 16.

Now: Reactants: C=14, H=18, N=2, O=37

Products: C=14, H=18, N=2, O=37

Balanced equation: $C_{14}H_{18}N_2O_5(s) + 16O_2(g) \rightarrow 9H_2O(l) + 14CO_2(g) + N_2(g)$

Chapter 15. Magnetism

End of chapter exercises:

1. Describe what is meant by the term magnetic field.

Solution:

It is a region in space where a magnet or object made of magnetic material will experience a non-contact force. A magnetic field has a north and south pole. The direction of the magnetic field is from the north to the south pole.

2. Use words and pictures to explain why permanent magnets have a magnetic field around them. Refer to domains in your explanation.

Solution:

Each electron has a magnetic field associated with it. In a ferromagnetic material, a material that a permanent magnet is made of, there are regions where the electrons' magnetic fields line up to point in the same direction. These regions are called domains and they have a net magnetic field. When a ferromagnetic material is magnetised, forming a permanent magnet, most or all these domains line up to create a net magnetic field over the whole object.



3. What is a magnet?

Solution:

A magnet is an object that has a net magnetic field caused by its electrons' magnetic fields being lined up. This net magnetic field causes a magnet to have a distinct north and south pole.

4. What happens to the poles of a magnet if it is cut into pieces?

Solution:

Each piece will have its own north and south pole. If the north pole of the whole magnet was at its right end, then the smaller piece's north pole will also be at its right end. The same holds for the south pole.

5. What happens when like magnetic poles are brought close together?

Solution:

They repel each other.

6. What happens when unlike magnetic poles are brought close together?

Solution:

They attract each other.

7. Draw the shape of the magnetic field around a bar magnet.

Solution

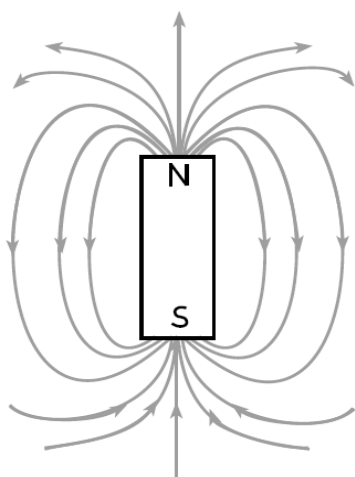

8. Explain how a compass indicates the direction of a magnetic field.

Solution:

The needle of a compass is magnetised. Therefore, when it is inside a magnetic field it will align itself with the direction of the field. The north pole of the needle will point to the south pole of the magnetic field.

9. Compare the magnetic field of the Earth to the magnetic field of a bar magnet using words and diagrams.

Solution:

The Earth has a magnetic north pole and south pole and it is surrounded by a magnetic field. This is the same for a bar magnet, except that the Earth's magnetic north pole corresponds to the south pole of a bar magnet. Similarly, the Earth's magnetic south pole corresponds to the north pole of a bar magnet.

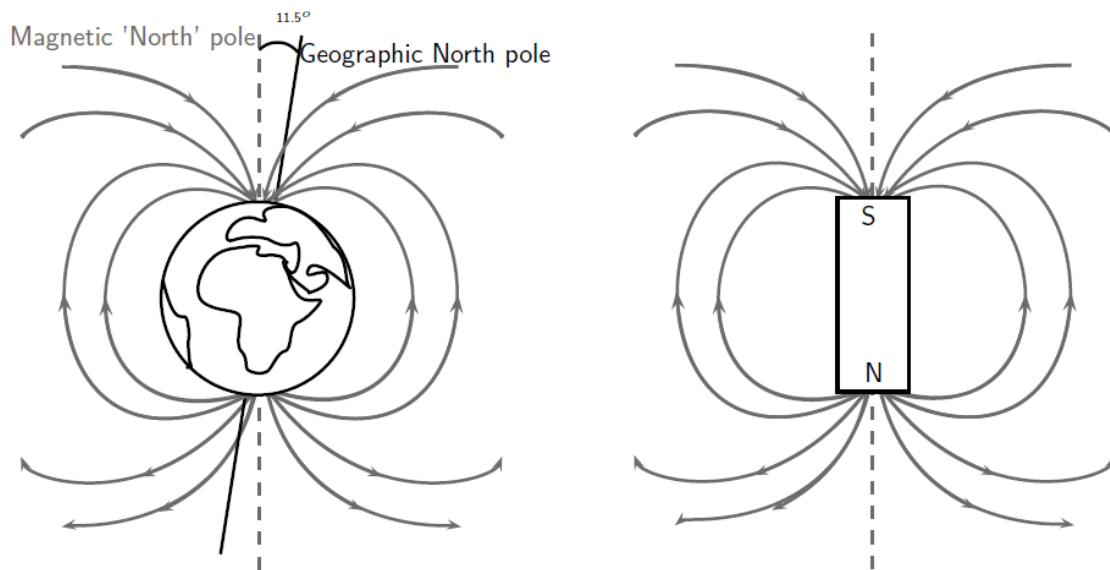

10. Explain the difference between the geographical north pole and the magnetic north pole of the Earth.

Solution:

The magnetic north pole is actually the south pole of the Earth's magnetic field. The geographical north pole is $11,5^\circ$ degrees away from the direction of the magnetic north pole. The Earth's rotation axis goes exactly through the geographical north pole. While the geographical north pole doesn't move, the magnetic north pole shifts slightly all the time.

11. Give examples of phenomena that are affected by Earth's magnetic field.

Solution:

The aurora.

Some animals, like bees and pigeons, detect Earth's magnetic field and use it to navigate.

12. Draw a diagram showing the magnetic field around the Earth.

Solution:

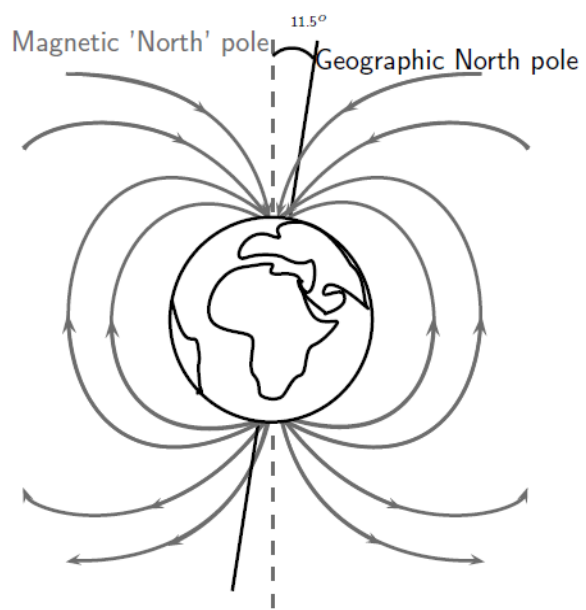

Chapter 16. Electrostatics

End of Chapter Exercises:

1. What are the two types of charge called?

Solution:

Positive charge and negative charge

2. Provide evidence for the existence of two types of charge.

Solution:

When rubbing certain materials against each other, we observe that some of the materials are able to attract or repulse other objects.

3. Fill in the blanks: The electrostatic force between like charges is _____ while the electrostatic force between opposite charges is _____ .

Solution:

The electrostatic force between like charges is **repulsive** while the electrostatic force between opposite charges is **attractive** .

4. I have two positively charged metal balls 2 m apart.

a) Is the electrostatic force attractive or repulsive?

b) If I now move the balls so that they are 1 m apart, what happens to the strength of the electrostatic force between them?

Solution:

a) Repulsive

b) The repulsive force will increase by a factor of 4.

5. I have 2 charged spheres each hanging from string as shown in the picture below.

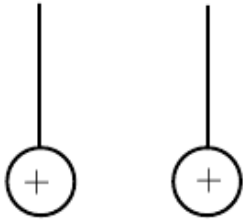

Choose the correct answer from the options below: The spheres will

- a. swing towards each other due to the attractive electrostatic force between them
- b. swing away from each other due to the attractive electrostatic force between them
- c. swing towards each other due to the repulsive electrostatic force between them
- d. swing away from each other due to the repulsive electrostatic force between them

Solution:

- d. swing away from each other due to the repulsive electrostatic force between them

6. Describe how objects (insulators) can be charged by contact or rubbing.

Solution:

When rubbing certain materials against each other, electrons can be transferred from the one material to the other, thereby giving the materials net charge.

7. You are given a perspex ruler and a piece of cloth

- a. How would you charge the perspex ruler?
- b. Explain how the ruler becomes charged in terms of charge.
- c. How does the ruler attract small pieces of paper?

Solution:

- a. The ruler can be charged by rubbing it with the piece of cloth
- b. Due to the rubbing, electrons are transferred from the cloth to the ruler, giving it a net negative charge. The cloth will therefore now have a net positive charge.
- c. The charged ruler will attract small pieces of paper through the process of polarisation. When the ruler is brought close to a piece of paper, the positive nuclei in the paper will move slightly close to the ruler and the electrons in the paper will move slightly away from the ruler. The piece of paper will then be slightly positively charged closest to the ruler and feel an attractive force.

8. An uncharged hollow metal sphere is placed on an insulating stand. A positively

charged rod is brought up to touch the hollow metal sphere at P as shown in the diagram below. It is then moved away from the sphere.

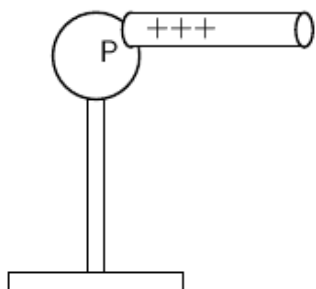

Where is the excess charged distributed on the sphere after the rod has been removed?

- a) It is still located at point P where the rod touched the sphere
- b) It is evenly distributed over the outer surface of the hollow sphere
- c) It is evenly distributed over the outer and inner surfaces of the hollow sphere
- d) No charge remains on the hollow sphere

Solution:

- b) It is evenly distributed over the outer surface of the hollow sphere

9. What is the process called where molecules in an uncharged object are caused to align in a particular direction due to an external charge?

Solution:

Polarisation

10. Explain how an uncharged object can be attracted to a charged object. You should use diagrams to illustrate your answer.

Solution:

When a charged object is brought close to an uncharged object, the uncharged object will be given a slight nett charge, opposite to the charge of the charged object. This process is called polarisation, see drawing below. Because the side of the uncharged object which is closest to the charged object has a nett charge due to polarisation, it will feel an attractive force to the charged object.

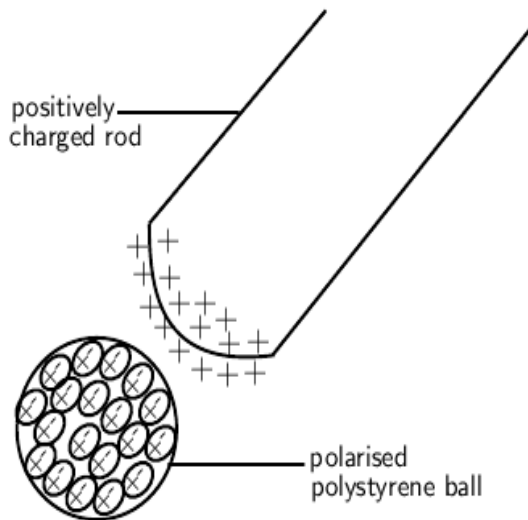

11. Explain how a stream of water can be attracted to a charged rod.

Solution:

Water molecules are polar, meaning they have positively and negatively charged sides. When a charged object is brought close to a stream of water, the molecules will feel an electrostatic force, causing the stream to be deflected.

12. An object has an excess charge of $-8,6 \times 10^{-18} \text{ C}$. How many excess electrons does it have?

Solution:

We know that charge is quantized and that electrons carry the base unit of charge which is $-1,6 \times 10^{-19} \text{ C}$.

As each electron carries the same charge the total charge must be made up of a certain number of electrons. To determine how many electrons we divide the total charge by the charge on a single electron:

$$N = \frac{-8,6 \times 10^{-18}}{-1,6 \times 10^{-19}} = 60 \text{ electrons}$$

13. An object has an excess of 235 electrons. What is the charge on the object?

Solution:

We know that charge is quantized and that electrons carry the base unit of charge which is

$$-1,6 \times 10^{-19} \text{ C} .$$

As each electron carries the same charge the total charge must be the sum of all the individual electron charges. We just need to multiply the base charge by the number of electrons:

$$Q = 235 \times (-1,6 \times 10^{-19}) = -376 \times 10^{-17} \text{ C}$$

14. An object has an excess of 235 protons. What is the charge on the object?

Solution:

We know that charge is quantized and that protons are positive and carry the base unit of charge which is $+1,6 \times 10^{-19} \text{ C}$.

As each proton carries the same charge the total charge must be the sum of all the individual proton charges. We just need to multiply the base charge by the number of protons:

$$Q = 235 \times 1,6 \times 10^{-19} = 376 \times 10^{-17} \text{ C}$$

15. Two identical, metal spheres have different charges. Sphere 1 has a charge of $-4,8 \times 10^{-18} \text{ C}$. Sphere 2 has 60 excess electrons. If the two spheres are brought into contact and then separated, what charge will each have? How many electrons does this correspond to?

Solution:

We need to know the charge on each sphere, we have been the charge on one.

We know that charge is quantized and that electrons carry the base unit of charge which is $-1,6 \times 10^{-19} \text{ C}$.

The total charge will therefore be: $Q = 60 \times (-1,6 \times 10^{-19}) = -9,6 \times 10^{-18} \text{ C}$

As the spheres are identical in material, size and shape the charge will redistribute across the two spheres so that it is shared evenly. Each sphere will have half of the total charge;

$$Q = \frac{Q_1 + Q_2}{2} = \frac{(-9,6 \times 10^{-18}) + (-4,8 \times 10^{-18})}{2} = 7,2 \times 10^{-18} \text{ C}$$

So each sphere now has $7,2 \times 10^{-18} \text{ C}$ of charge.

As each electron carries the same charge the total charge must be made up of a certain number of electrons. To determine how many electrons we divide the total charge by the charge on a single electron:

$$N = \frac{-7,2 \times 10^{-18}}{-1,6 \times 10^{-19}} = 45 \text{ electrons}$$

16. Two identical, insulated spheres have different charges. Sphere 1 has a charge of $-96 \times 10^{-18} \text{ C}$. Sphere 2 has 60 excess electrons. If the two spheres are brought into contact and then separated, what charge will each have?

Solution:

The spheres are insulators so we know they will NOT allow charge to move freely. When they touch nothing will happen.

17. Two identical, metal spheres have different charges. Sphere 1 has a charge of $-4,8 \times 10^{-18} \text{ C}$. Sphere 2 has 30 excess protons. If the two spheres are brought into contact and then separated, what charge will each have? How many electrons or protons does this correspond to?

Solution:

The total charge is:

$$\begin{aligned} Q_2 &= 30 \times 1,6 \times 10^{-19} \text{ C} \\ &= 4,8 \times 10^{-18} \text{ C} \end{aligned}$$

As the spheres are identical in material, size and shape the charge will redistribute across the two spheres so that it is shared evenly. Each sphere will have half of the total charge;

$$\begin{aligned} Q &= \frac{Q_1 + Q_2}{2} \\ &= \frac{4,8 \times 10^{-18} + -4,8 \times 10^{-18}}{2} \\ &= 0 \text{ C} \end{aligned}$$

So each sphere is now neutral.

No net charge means that there is no excess of electrons or protons.

Chapter 17. Electric circuits

Exercise 17-1:

1. What is the unit of resistance called and what is its symbol?

Solution:

The unit of resistance is ohm and the symbol is Ω

2. Explain what happens to the total resistance of a circuit when resistors are added in series?

Solution:

When resistors are added in series to the circuit the total resistance increases. The total resistance is the sum of the individual values of the resistors. ($R_s = R_1 + R_2 + R_3 + \dots$)

3. Explain what happens to the total resistance of a circuit when resistors are added in parallel?

Solution:

When resistors are added in parallel to the circuit the total resistance decreases. The total resistance is: $\frac{1}{R_{\text{total}}} = \frac{1}{r_1} + \frac{1}{r_2} + \dots$ where R is the total resistance and r1, r2, etc. is the resistance of the individual resistors.

4. Why do batteries go flat?

Solution:

A battery stores chemical potential energy. When it is connected in a circuit, a chemical reaction takes place inside the battery which converts chemical potential energy to electrical energy which powers the electrons to move through the circuit. All the circuit elements (such as the conducting leads, resistors and light bulbs) have some resistance to the flow of charge and convert the electrical energy to heat and, in the case of the light bulb, light. Since energy is always conserved, the battery goes flat when all its chemical potential energy has been converted into other forms of energy.

End of chapter exercises:

1. Write definitions for each of the following:

- a) resistor
- b) coulomb
- c) voltmeter

Solution:

a) A resistor is a physical component of a circuit that has resistance. Resistance is defined as the ratio of the voltage and the current through a physical component, as defined by Ohm's law.

b) A coulomb is a unit of charge.

c) A voltmeter is a device that measures the potential difference (in Volts) across a physical component, when connected in parallel with that component.

2. Draw a circuit diagram which consists of the following components:

- a) 2 batteries in parallel
- b) an open switch
- c) 2 resistors in parallel
- d) an ammeter measuring total current
- e) a voltmeter measuring potential difference across one of the parallel resistors

Solution:

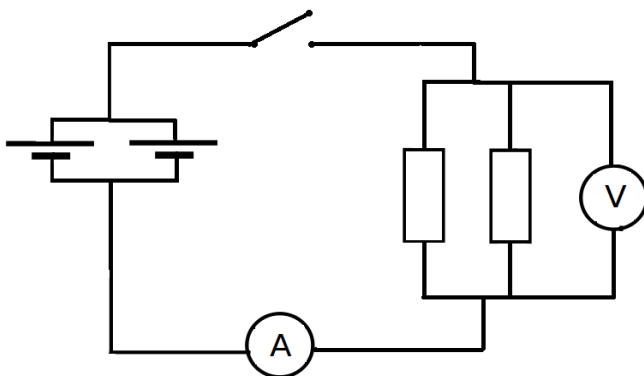

3. Complete the table below:

Quantity	Symbol	Unit of measurement	Symbol of unit
e.g. distance	e.g. d	e.g. metres	e.g. m
Resistance			
Current			
Potential difference			

Solution:

Quantity	Symbol	Unit of measurement	Symbol of unit
e.g. distance	e.g. d	e.g. metres	e.g. m
Resistance	R	Ohms	Ω
Current	I	Amperes	A
Potential difference	V	Volts	V

4. The emf of a battery can best be explained as the . . .

- a) rate of energy delivered per unit current
- b) rate at which charge is delivered
- c) rate at which energy is delivered
- d) charge per unit of energy delivered by the battery

Solution:

- a) rate of energy delivered per unit current

5. Which of the following is the correct definition of the emf of a battery?

- a) It is the product of current and the external resistance of the circuit.
- b) It is a measure of the cell's ability to conduct an electric current.
- c) It is equal to the "lost volts" in the internal resistance of the circuit.

d) It is the power supplied by the battery per unit current passing through the battery.

Solution:

d) It is the power supplied by the battery per unit current passing through the battery.

6. Three identical light bulbs A, B and C are connected in an electric circuit as shown in the diagram below.

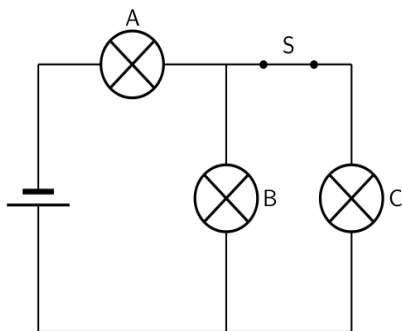

a) How bright is bulb A compared to B and C?

b) How bright are the bulbs after switch S has been opened?

c) How do the currents in bulbs A and B change when switch S is opened? (Write only the letter from the table below.)

	Current in A	Current in B
a)	decreases	increases
b)	decreases	decreases
c)	increases	increases
d)	increases	decreases

Solution:

a) Bulb A will be brighter than B and C as there is more current flowing through it.

b) Bulb A and B will be equally bright, but bulb C will not be lit up. (When the switch opens, no current flows through bulb C and bulbs A and B are now in series.)

c) b

7. When a current I is maintained in a conductor for a time of t , how many electrons with charge e pass any cross-section of the conductor per second?

- a) It
- b) It/e
- c) Ite
- d) e/It

Solution:

- a) It

8. If you have a circuit consisting of 4 resistors of equal resistance in series and the total voltage across all of them is 17V , what is the voltage across each of them?

Solution:

Resistance of 1 resistor is V_R . In series the resistors are voltage dividers and identical, so the voltage across each is the same. The voltage of the battery will be equal to the sum of voltage in a series circuit.

$$\begin{aligned}V_{\text{Battery}} &= V_R + V_R + V_R + V_R \\17\text{V} &= 4V_R \\V_R &= \frac{17}{4}\text{V} \\&= 4,25\text{V}\end{aligned}$$

9. If you have a circuit consisting of 4 resistors of equal resistance in parallel and the total voltage across all of them is 17V , what is the voltage across each of them?

Solution:

The voltage across the parallel set up is the same as the voltage across each resistor

$$V_R = 17\text{V}$$

10. In a circuit consisting of a battery and 3 resistors in series, what is the voltage across the first resistor if the voltage across the battery is 12V and the voltages across the other

two resistors is 3~V and 2~V respectively?

Solution:

$$\begin{aligned}V_s &= V_1 + V_2 + \dots \\12V &= 3V + 2V + V_{\text{unknown}} \\V_{\text{unknown}} &= 7V\end{aligned}$$

11. There are 3 resistors in parallel with resistances of 3Ω , 4Ω and 11Ω . What is the total resistance of the parallel combination?

Solution:

$$\begin{aligned}R_1 &= 3\Omega \\R_2 &= 4\Omega \\R_3 &= 11\Omega\end{aligned}$$

$$\frac{1}{R_p} = \frac{1}{R_1} + \frac{1}{R_2} + \frac{1}{R_3}$$

$$\begin{aligned}R_p &= \frac{R_1 R_2 R_3}{R_1 R_2 + R_2 R_3 + R_1 R_3} \\&= \frac{(3)(4)(11)}{12 + 44 + 33} \\&= \frac{132}{89} \\&= 1,4\Omega\end{aligned}$$

12. The same three resistors as above are now arranged in series, 3Ω , 4Ω and 11Ω . What is the total resistance of the series combination?

Solution:

$$\begin{aligned}R_s &= R_1 + R_2 + \dots \\&= 3\Omega + 4\Omega + 11\Omega \\&= 18\Omega\end{aligned}$$

13. The total resistance of two resistors in parallel is 3Ω , the one resistor has a resistance of 5Ω , what is the resistance of the other resistor?

Solution:

$$R_p = 3\Omega$$

$$R_1 = 5\Omega$$

$$R_2 = ?$$

$$R_p = \frac{R_1 R_2}{R_1 + R_2}$$

$$R_p(R_1 + R_2) = R_1 R_2$$

$$R_p R_1 + R_p R_2 - R_1 R_2 = 0$$

$$R_2(R_p - R_1) = -R_p R_1$$

$$R_2 = \frac{-R_p R_1}{R_p - R_1}$$

$$= \frac{-(3)(5)}{3-5}$$

$$= \frac{-15}{-2}$$

$$= 7,5\Omega$$

14. In a series circuit there are 3 resistors with voltages of 2~V, 5~V and 8~V, what is the voltage across the battery in the circuit?

Solution:

$$V_{\text{Battery}} = V_1 + V_2 + \dots$$

In series,
$$V_{\text{Battery}} = 2\text{V} + 5\text{V} + 8\text{V}$$
$$= 15 \text{ V}$$

15. In a parallel circuit there are 3 resistors with voltages of 2~V, 2~V and 2~V, what is the voltage across the battery in the circuit?

Solution:

$$V_{\text{Battery}} = 2 \text{ V} \quad \text{in a parallel circuit.}$$

Chapter 18. Reactions in aqueous solution

Exercise 18-1:

1. For each of the following say whether the substance is ionic or molecular

- a) Potassium nitrate (KNO_3)
- b) Ethanol ($\text{C}_2\text{H}_5\text{OH}$)
- c) Sucrose (a type of sugar) ($\text{C}_{12}\text{H}_{22}\text{O}_{11}$)
- d) Sodium bromide (NaBr)

Solution:

- a) Ionic
- b) Molecular
- c) Molecular
- d) Ionic

2. Write a balanced chemical equation to show how each of the following ionic compounds dissociates in water.

- a) Sodium sulphate (Na_2SO_4)
- b) Potassium bromide (KBr)
- c) Potassium permanganate (KMnO_4)
- d) Sodium phosphate (Na_3PO_4)

Solution:

- a) $\text{Na}_2\text{SO}_4 (\text{s}) \rightarrow 2\text{Na}^+ (\text{aq}) + \text{SO}_4^{2-} (\text{aq})$
- b) $\text{KBr} (\text{s}) \rightarrow \text{K}^+ (\text{aq}) + \text{Br}^- (\text{aq})$
- c) $\text{KMnO}_4 (\text{s}) \rightarrow \text{K}^+ (\text{aq}) + \text{MnO}_4^- (\text{aq})$
- d) $\text{Na}_3\text{PO}_4 (\text{s}) \rightarrow 3\text{Na}^+ (\text{aq}) + \text{PO}_4^{3-} (\text{aq})$

3. Draw a diagram to show how KCl dissociates in water.

Solution:

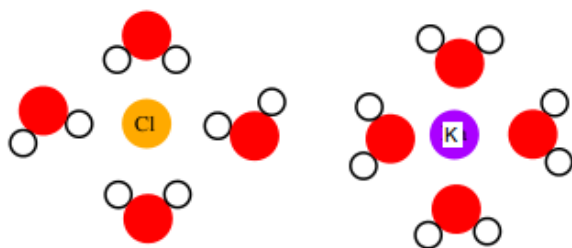

Exercise 18-2:

1. Silver nitrate (AgNO_3) reacts with potassium chloride (KCl) forming a white precipitate.

- Write a balanced equation for the reaction that takes place. Include the state symbols.
- What is the name of the insoluble salt that is formed?
- Which of the salts in this reaction are soluble?

Solution:

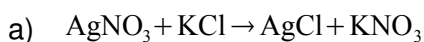

Alternatively since KNO_3 is soluble we could write:



- Silver chloride
- Potassium nitrate.

2. Barium chloride reacts with sulphuric acid to produce barium sulphate and hydrochloric acid.

- Write a balanced equation for the reaction that takes place. Include the state symbols.
- Does a precipitate form during the reaction?
- Describe a test that could be used to test for the presence of barium sulphate in the products.

Solution:

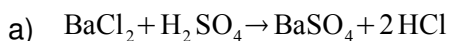

b) Yes. BaSO_4

c) Barium sulphate is unaffected by nitric acid so if one adds nitric acid the precipitate will remain unchanged.

3. A test tube contains a clear, colourless salt solution. A few drops of silver nitrate solution are added to the solution and a pale yellow precipitate forms. Chlorine water and carbon tetrachloride were added, which resulted in a purple solution. Which one of the following salts was dissolved in the original solution? Write the balanced equation for the reaction that took place between the salt and silver nitrate.

a) NaI

b) KCl

c) K_2CO_3

d) Na_2SO_4

Solution:

Answer a). The salt is sodium iodide. The balanced equation is:

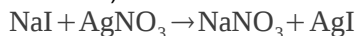

End of chapter exercises:

1. Give one word for each of the following descriptions:

a) the change in phase of water from a gas to a liquid

b) a charged atom

c) a term used to describe the mineral content of water

d) a gas that forms sulphuric acid when it reacts with water

Solution:

a) Condensation

b) Ion

c) Water hardness

d) Sulphur trioxide (SO_3)

2. Match the information in column A with the information in column B by writing only the letter (A to I) next to the question number (1 to 7)

Column A	Column B
1. A polar molecule	A. H_2SO_4
2. molecular solution	B. CaCO_3
3. Mineral that increases water hardness	C. <u>NaOH</u>
4. Substance that increases the hydrogen ion concentration	D. salt water
5. A strong electrolyte	E. calcium
6. A white precipitate	F. carbon dioxide
7. A non-conductor of electricity	G. potassium nitrate
	H. sugar water
	I. O_2

Solution:

- 1) B
- 2) H
- 3) E
- 4) A
- 5) C
- 6) B
- 7) I

3. Explain the difference between a weak electrolyte and a strong electrolyte. Give a generalised equation for each.

Solution:

A strong electrolyte ionises completely in water, while a weak electrolyte only ionises partially. In a strong electrolyte all the substance is found as ions, while in a weak electrolyte some of the molecules do not dissociate.

A strong electrolyte may be represented by:

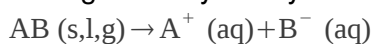

A weak electrolyte may be represented by:

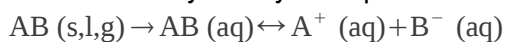

4. What factors affect the conductivity of water? How do each of these affect the conductivity?

Solution:

The type of substance: whether a substance is a strong electrolyte, a weak electrolyte or a non electrolyte affects the concentration of ions in solution.

The concentration of ions in solution: The more ions there are in solution, the greater the conductivity will be.

The temperature: Higher temperatures increase solubility and so increase the concentration of ions in solution.

5. For each of the following substances state whether they are molecular or ionic. If they are ionic, give a balanced reaction for the dissociation in water.

- Methane (CH_4)
- potassium bromide
- carbon dioxide
- hexane (C_6H_{14})
- lithium fluoride (LiF)
- magnesium chloride

Solution:

- Molecular
- Ionic $\text{KBr} + \text{H}_2\text{O} \rightarrow \text{K}^+ + \text{Br}^- + \text{H}_2\text{O}$
- Molecular
- Molecular
- Ionic $\text{LiF} + \text{H}_2\text{O} \rightarrow \text{Li}^+ + \text{F}^- + \text{H}_2\text{O}$
- Ionic $\text{MgCl}_2 + \text{H}_2\text{O} \rightarrow \text{Mg}^{2+} + 2\text{Cl}^- + \text{H}_2\text{O}$

6. Three test tubes (X, Y and Z) each contain a solution of an unknown potassium salt. The following observations were made during a practical investigation to identify the solutions in the test tubes:

A: A white precipitate formed when silver nitrate (AgNO_3) was added to test tube Z.

B: A white precipitate formed in test tubes X and Y when barium chloride (BaCl_2) was added.

C: The precipitate in test tube X dissolved in hydrochloric acid (HCl) and a gas was released.

D: The precipitate in test tube Y was insoluble in hydrochloric acid.

- a) Use the above information to identify the solutions in each of the test tubes X, Y and Z.
- b) Write a chemical equation for the reaction that took place in test tube X before hydrochloric acid was added.

Solution:

a) X: Carbonate solution

Y: Sulphate solution

Z: Chloride solution

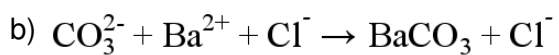

Chapter 19. Quantitative aspects of chemical change

Exercise 19-1:

1. How many atoms are there in:

- a) 1 mole of a substance
- b) 2 moles of calcium
- c) 5 moles of phosphorus
- d) 24,3 g of magnesium
- e) 24,0 g of carbon

Solution:

a) The number of atoms is given by Avogadro's number. To determine the number of atoms in a sample we only need the number of moles, we do not need to know what the substance is. So the number of atoms in 1 mole of a substance is:

$$1 \times (6,02 \times 10^{23}) = 6,02 \times 10^{23}$$

b) In 2 moles of calcium there are: $2 \times (6,02 \times 10^{23}) = 1,204 \times 10^{24}$

c) In 5 moles of phosphorus there are: $5 \times (6,02 \times 10^{23}) = 3,01 \times 10^{24}$

d) Before we can work out the number of atoms, we must work out the number of moles. The relative atomic mass of magnesium is 24,31 u.

So we have 1 mole of magnesium. (Relative atomic mass = sample mass)

The number of atoms are: $1 \times (6,02 \times 10^{23}) = 6,02 \times 10^{23}$

e) The relative atomic mass of carbon is 12,01 u

The number of moles in the sample is 2. (Relative atomic mass = half sample mass)

The number of atoms is: $2 \times (6,02 \times 10^{23}) = 1,204 \times 10^{24}$

2. Complete the following table:

Element	Relative atomic mass (u)	Sample mass (g)	Number of moles in the sample
Hydrogen	1,01	1,01	
Magnesium	24,3	24,3	
Carbon	12,0	24,0	
Chlorine	35,45	70,9	
Nitrogen	14,0	42,0	

Solution:

The relative atomic mass for nitrogen is the value written on the periodic table. To work out the number of moles in the sample we note that when we have one mole of a substance we have the same sample mass and relative atomic mass.

For hydrogen we have 1,01 g of sample and 1,01 u for relative atomic mass, so we have one mole of hydrogen. For carbon we have 24,0 g of sample and 12,0 u for relative atomic mass, so we have two moles of substance ($12,01 \times 2 = 24,02$)

Doing this for the rest of the elements in the table we get:

Element	Relative atomic mass (u)	Sample mass (g)	Number of moles in the sample
Hydrogen	1,01	1,01	1
Magnesium	24,3	24,3	1
Carbon	12,0	24,0	2
Chlorine	35,45	70,9	2
Nitrogen	14,0	42,0	3

Exercise 19-2:

1. Give the molar mass of each of the following elements:

a) hydrogen gas

b) nitrogen gas

c) bromine gas

Solution:

We simply find the element on the periodic table and read off its molar mass.

- a) $1,01 \text{ g} \cdot \text{mol}^{-1}$
- b) $14,01 \text{ g} \cdot \text{mol}^{-1}$
- c) $79,9 \text{ g} \cdot \text{mol}^{-1}$

2. Calculate the number of moles in each of the following samples:

- a) 21,6 g of boron (B)
- b) 54,9 g of manganese (Mn)
- c) 100,3 g of mercury (Hg)
- d) 50 g of barium (Ba)
- e) 40 g of lead (Pb)

Solution:

a) Molar mass of boron is: $10,8 \text{ g} \cdot \text{mol}^{-1}$

If one mole of boron has a mass of 10 g then the number of moles of boron in 21,6 g must

be:
$$\frac{21,6 \text{ g}}{10,8 \text{ g} \cdot \text{mol}^{-1}} = 2 \text{ mol}$$

b) Molar mass of manganese is: $54,9 \text{ g} \cdot \text{mol}^{-1}$

If one mole of manganese has a mass of 59,908 g then the number of moles of

manganese in 54,94 g must be:
$$\frac{54,9 \text{ g}}{54,9 \text{ g} \cdot \text{mol}^{-1}} = 1 \text{ mol}$$

c) Molar mass of mercury is: $200,6 \text{ g} \cdot \text{mol}^{-1}$

If one mole of mercury has a mass of 200,6 g then the number of moles of manganese in

100,03 g must be:
$$\frac{100,3 \text{ g}}{200,6 \text{ g} \cdot \text{mol}^{-1}} = 0,5 \text{ mol}$$

d) Molar mass of barium is: $137,3 \text{ g} \cdot \text{mol}^{-1}$

If one mole of barium has a mass of 137,3 g then the number of moles of barium in 50 g

must be:
$$\frac{50 \text{ g}}{137,3 \text{ g} \cdot \text{mol}^{-1}} = 0,36 \text{ mol}$$

e) Molar mass of lead is: $207,2 \text{ g}\cdot\text{mol}^{-1}$

If one mole of lead has a mass of 207,2 g then the number of moles of lead in 40 g must

be: $\frac{40 \text{ g}}{207,2 \text{ g}\cdot\text{mol}^{-1}} = 0,19 \text{ mol}$

Exercise 19-3:

1. Calculate the number of moles in each of the following samples:

a) 5.6 g of calcium

b) 0,02 g of manganese

c) 40 g of aluminium

Solution:

a) Molar mass of calcium: $40,08 \text{ g}\cdot\text{mol}^{-1}$

$$n = \frac{m}{M} = \frac{5,6}{40,08} = 0,140 \text{ mol}$$

b) Molar mass of manganese: $54,94 \text{ g}\cdot\text{mol}^{-1}$

$$n = \frac{m}{M} = \frac{0,02}{54,94} = 0,00036 \text{ mol}$$

c) Molar mass of aluminium: $26,98 \text{ g}\cdot\text{mol}^{-1}$

2. A lead sinker has a mass of 5 g.

a) Calculate the number of moles of lead the sinker contains.

b) How many lead atoms are in the sinker?

Solution:

a) Molar mass of lead: $207,2 \text{ g}\cdot\text{mol}^{-1}$

$$n = \frac{m}{M} = \frac{5}{207,2} = 0,024 \text{ mol}$$

$$b) 0,024 \times (6,02 \times 10^{23}) = 1,44 \times 10^{22}$$

3. Calculate the mass of each of the following samples:

a) 2,5 mol magnesium

b) 12 mol lithium

c) $4,5 \times 10^{25}$ atoms of silicon

Solution:

a) Molar mass of magnesium:

$$24,31 \text{ g} \cdot \text{mol}^{-1}$$

$$n = \frac{m}{M}$$

$$m = nM$$

$$m = 60,775 \text{ g}$$

b) Molar mass of lithium:

$$6,94 \text{ g} \cdot \text{mol}^{-1}$$

$$m = nM$$

$$m = (12)(6,94)$$

$$m = 83,28 \text{ g}$$

c) Number of moles of silicon

$$4,5 \times 10^{25} \div 6,02 \times 10^{23} = 74,751 \text{ mol}$$

Silicon has a mass of $28 \text{ g} \cdot \text{mol}^{-1}$.

The mass of the sample is:

$$m = n \times M$$

$$m=74,751 \times 28$$

$$m=2093g$$

Exercise 19-4:

1. Calculate the molar mass of the following chemical compounds:

a) KOH

b) FeCl₃

c) Mg(OH)₂

Solution:

a) Molar mass = molar mass K + molar mass O + molar mass H

$$39,10 + 16,00 + 1,01 = 56,11g \cdot mol^{-1}$$

b) Molar mass = molar mass Fe + 3 molar mass Cl

$$55,85 + 3(35,45) = 162,2g \cdot mol^{-1}$$

c) Molar mass = molar mass Mg + 2 molar mass O + 2 molar mass H (note that the OH part is multiplied by 2.)

$$24,31 + 2(16,00) + 2(1,01) = 58,33g \cdot mol^{-1}$$

2. How many moles are present in:

a) 10 g of Na₂SO₄

b) 34 g of Ca(OH)₂

c) $2,45 \times 10^{23}$ molecules of CH₄

Solution:

a) Molar mass of Na_2SO_4 is:

$$2(22,99) + 32,06 + 4(16,00) = 142,04 \text{g}\cdot\text{mol}^{-1}$$

$$n = \frac{m}{M}$$

$$n = \frac{10}{142,04}$$

$$n = 0,07 \text{ mol}$$

b) Molar mass of $\text{Ca}(\text{OH})_2$:

$$40,08 + 2(16,00) + 2(1,01) = 74,1 \text{g}\cdot\text{mol}^{-1}$$

$$n = \frac{m}{M}$$

$$n = \frac{34}{74,1}$$

$$n = 0,46 \text{ mol}$$

c) We divide by Avogadro's number to get the number of moles:

$$\frac{2,45 \times 10^{23}}{6,022 \times 10^{23}} = 0,41 \text{ mol}$$

3. For a sample of 0,2 moles of magnesium bromide (MgBr_2), calculate:

a) the number of moles of Mg^+ ions

b) the number of moles of Br^- ions

Solution:

a) 0,2 mol

b) 0,4 mol

4. You have a sample containing 3 moles of calcium chloride.

a) What is the chemical formula of calcium chloride?

b) How many calcium atoms are in the sample?

Solution:

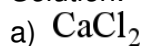

b) There are 3 moles of calcium atoms. The number of calcium atoms is:

$$3 \times (6,022 \times 10^{23}) = 1,81 \times 10^{24}$$

5. Calculate the mass of:

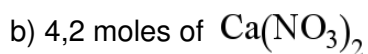
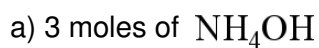

Solution:

a) Molar mass of NH_4OH is:

$$14,01 + 4(1,01) + 16,00 + 1,01 = 35,06 \text{g} \cdot \text{mol}^{-1}$$

Mass is:

$$m = nM$$

$$m = (3)(35,06)$$

$$m = 105,18 \text{g}$$

b) Molar mass of $\text{Ca}(\text{NO}_3)_2$ is:

$$40,08 + 2(14,01) + 6(16,00) = 164,1 \text{g} \cdot \text{mol}^{-1}$$

Mass:

$$m = nM$$

$$m = (4,2)(164,1)$$

$$m = 689,22 \text{g}$$

Exercise 19-5:

1. Calcium chloride is produced as the product of a chemical reaction.
- What is the formula of calcium chloride?
 - What percentage does each of the elements contribute to the mass of a molecule of calcium chloride?
 - If the sample contains 5 g of calcium chloride, what is the mass of calcium in the sample?
 - How many moles of calcium chloride are in the sample?

Solution:



b) The percentage by mass is the atomic mass of the element divided by the molecular mass of the compound:

$$\text{Ca: } \% \text{ mass} = \frac{40,08}{110,98} \times 100 = 36,15 \%$$

$$\text{Cl: } \% \text{ mass} = \frac{2(35,45)}{110,98} \times 100 = 63,89 \%$$

If we add these up we get 100%: $36,15 + 63,89 = 100$

c) Calcium makes up 36,15% of the calcium chloride, so the mass of calcium in the sample must be 36,15% of 5g:

$$m = 5 \times \frac{36,15}{100} = 1,808 \text{ g}$$

d) The number of moles is:

$$n = \frac{m}{M}$$

$$n = \frac{1,808}{40,08}$$

$$n = 0,045 \text{ mol}$$

(Notice that this is the same as the number of moles in 5g of calcium chloride:

$$n = \frac{5}{110,9} = 0,045 \text{ mol })$$

2. 13g of zinc combines with 6,4g of sulphur.

a) What is the empirical formula of zinc sulphide?

b) What mass of zinc sulphide will be produced?

c) What percentage does each of the elements in zinc sulphide contribute to its mass?

d) The molar mass of zinc sulphide is found to be $97,44\text{g}\cdot\text{mol}^{-1}$. Determine the molecular formula of zinc sulphide.

Solution:

a) We work out the number of moles of each reactant:

$$\text{Zinc: } n = \frac{m}{M}$$

$$n = \frac{13}{65,38}$$

$$n = 0,20\text{mols}$$

$$\text{Sulphur: } n = \frac{m}{M}$$

$$n = \frac{6,4}{32,06}$$

$$n = 0,20\text{mol}$$

Zinc and sulphur combine in a 1:1 ratio, i.e. there 1 atom of zinc reacts with 1 atom of sulphur. The empirical formula of zinc sulphide is therefore:

ZnS

b) The mass of zinc sulphide produced is:

$$m = nM$$

$$m = (0,20)(97,44)$$

$$m = 19,45\text{g}$$

$$\text{c) Zinc: } \frac{65,38}{97,44} \times 100 = 67\%$$

$$\text{Sulphur: } \frac{32,06}{97,44} \times 100 = 33\%$$

d) The molecular mass from the empirical formula is the same as the molecular mass of the molecular formula and so the molecular formula is: ZnS

3. A calcium mineral consists of 29,4% calcium, 23,5% sulphur and 47,1% oxygen by mass. Calculate the empirical formula of the mineral.

Solution:

In 100g of the mineral there will be 29,4 g calcium, 23,5 g sulphur and 47,1 g oxygen. We can calculate the number of moles for each of these:

$$\text{Calcium: } n = \frac{m}{M}$$

$$n = \frac{29,4}{40,08}$$

$$n = 0,73 \text{ mol}$$

$$\text{Sulphur: } n = \frac{m}{M}$$

$$n = \frac{23,5}{32,06}$$

$$n = 0,73 \text{ mol}$$

$$\text{Oxygen: } n = \frac{m}{M}$$

$$n = \frac{47,1}{16,00}$$

$$n = 2,95 \text{ mol}$$

The smallest number is 0,73 so we divide all the values by 0,73.

This gives 1 for calcium and sulphur and $\frac{2,95}{0,73} = 4$ for oxygen.

So the molar ratio of the mineral is: 1:1:4 and the empirical formula is:



4. A chlorinated hydrocarbon compound was analysed and found to consist of 24,24% carbon, 4,04% hydrogen and 71,72% chlorine. From another experiment the molecular mass was found to be $99 \text{ g} \cdot \text{mol}^{-1}$. Deduce the empirical and molecular formula.

Solution:

In 100g of the mineral there will be 24,24 g carbon, 4,04 g hydrogen and 71,72 g chlorine.

We can calculate the number of moles for each of these:

$$\text{Carbon: } n = \frac{m}{M}$$

$$n = \frac{24,24}{12,011}$$

$$n = 2 \text{ mol}$$

$$\text{Hydrogen: } n = \frac{m}{M}$$

$$n = \frac{4,04}{1,01}$$

$$n = 4 \text{ mol}$$

$$\text{Chlorine: } n = \frac{m}{M}$$

$$n = \frac{71,72}{35,45}$$

$$n = 2 \text{ mol}$$

The smallest number is 2 so we divide all the values by 2.

This gives 1 for carbon and chlorine and 2 for hydrogen.

So the molar ratio of the mineral is: 1:2:1 and the empirical formula is:

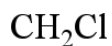

The molecular mass is:

$$12,011 + 1,01 + 35,45 = 48,471 \text{ g} \cdot \text{mol}^{-1}$$

The molecular mass of the compound is found to $99 \text{ g} \cdot \text{mol}^{-1}$

The empirical formula must be multiplied by: $\frac{99}{48,471} = 2$

The molecular formula is therefore: $\text{C}_2\text{H}_4\text{Cl}_2$

5. Magnesium sulphate has the formula $MgSO_4 \cdot nH_2O$. A sample containing 5,0 g of magnesium sulphate was heated until all the water had evaporated. The final mass was found to be 2,6 g. How many water molecules were in the original sample?

Solution:

We first need to find n, the number of water molecules that are present in the crystal. To do this we first note that the mass of water lost is $5 - 2,6 = 2,4$ g.

The mass ratio is: 2,6:2,4

To work out the mole ratio we divide the mass ratio by the molecular mass of each species:

$$\frac{2,6}{120,4} : \frac{2,4}{18,02} = 0,021594684 : 0,13318535$$

1:6

So the number of water molecules is 6 and the formula is: $MgSO_4 \cdot 6H_2O$

Exercise 19-6:

1. 5,95 g of potassium bromide (KBr) was dissolved in 400 cm^3 of water. Calculate its concentration.

Solution:

We use $C=nV$ to calculate the concentration.

First we need to find n:

The molecular formula for potassium bromide is KBr. The molar mass of potassium bromide is:

$$39,1 + 79,9 = 119 \text{ g} \cdot \text{mol}^{-1}$$

The number of moles is:

$$n = \frac{m}{M}$$

$$n = \frac{5,95}{119}$$

$$n = 0,05 \text{ mol}$$

We need to also convert the volume to the correct units:

$$\frac{400 \text{ cm}^3}{1000} = 0,4 \text{ dm}^3$$

Finally we work out the concentration:

$$C = nV$$
$$C = (0,05)(0,4)$$
$$C = 0,02 \text{ mol} \cdot \text{dm}^3$$

2. 100 g of sodium chloride (NaCl) is dissolved in 450 cm^3 of water.

a) How many moles of NaCl are present in solution?

b) What is the volume of water (in dm^3)?

c) Calculate the concentration of the solution.

Solution:

a) The molar mass of sodium chloride is:

$$58,45 \text{ g} \cdot \text{mol}^{-1}$$

The number of moles of sodium chloride is:

$$n = \frac{m}{M}$$
$$n = \frac{100}{58,45}$$
$$n = 1,71 \text{ mol}$$

b) To convert from cm^3 to dm^3 we divide by 1 000:

$$\frac{450}{1000} = 0,45 \text{ dm}^3$$

c) The concentration is:

$$C = nV$$
$$C = 1,71 \times 0,45$$
$$C = 0,77 \text{ mol} \cdot \text{dm}^{-3}$$

3. What is the molarity of the solution formed by dissolving 80 g of sodium hydroxide (NaOH) in 500 cm^3 of water?

Solution:

The molar mass of sodium hydroxide is: $22,99 + 1,01 + 15,99 = 39,99 \text{ g} \cdot \text{mol}^{-1}$

The number of moles of sodium hydroxide is:

$$n = \frac{m}{M}$$

$$n = \frac{80}{39,95}$$

$$n = 2 \text{ mol}$$

$$\frac{500 \text{ cm}^3}{1000} = 0,5 \text{ dm}^3$$

The concentration is:

$$C = \frac{n}{V}$$

$$C = \frac{2}{0,5}$$

$$C = 4 \text{ mol} \cdot \text{dm}^{-3}$$

4. What mass (g) of hydrogen chloride (HCl) is needed to make up 1000 cm^3 of a solution of concentration $1 \text{ mol} \cdot \text{dm}^{-3}$?

Solution:

$$\frac{1000 \text{ cm}^3}{1000} = 1 \text{ dm}^3$$

The number of moles of hydrogen chloride is:

$$n = CV$$

$$n = (1)(1)$$

$$n = 1 \text{ mol}$$

The molar mass of hydrogen chloride is:

$$1,01 + 35,45 = 36,46 \text{ g} \cdot \text{mol}^{-1}$$

The mass of hydrogen chloride needed is:

$$m = nM$$

$$m=(1)(36,46)$$

$$m=36,46g$$

5. How many moles of H_2SO_4 are there in $250cm^3$ of a $0,8mol \cdot dm^{-3}$ sulphuric acid solution? What mass of acid is in this solution?

Solution:

$$\frac{250cm^3}{1000}=0,25dm^3$$

The number of moles is:

$$n=CV$$

$$n=(0,8)(0,25)$$

$$n=0,2mol$$

The molar mass of H_2SO_4 is:

$$2(1,01) + 4(15,99) + 32,07=98,05g \cdot mol^{-1}$$

The mass of H_2SO_4 is:

$$m=nM$$

$$m=(0,2)(98,05)$$

$$m=19,61g$$

Exercise 19-7:

1. Diborane, B_2H_6 , was once considered for use as a rocket fuel. The combustion reaction for diborane is: $B_2H_6(g) + 3O_2(g) \rightarrow 2HBO_2(g) + 2H_2O(l)$

If we react 2,37 grams of diborane, how many grams of water would we expect to produce?

Solution:

The molar mass of diborane is: $2(10,81) + 6(1,01) = 27,68 \text{ g} \cdot \text{mol}^{-1}$

The number of moles of diborane is:

$$n = \frac{m}{M}$$

$$n = \frac{2,37}{27,68}$$

$$n = 0,086 \text{ mol}$$

For every mole of diborane we get two moles of water and so the number of moles of water is: $2(0,086) = 0,17 \text{ mol}$

The molar mass of water is: $2(0,086) = 0,17 \text{ mol}$

And the mass of water is: $15,99 + 2(1,01) = 18,01 \text{ g} \cdot \text{mol}^{-1}$

$$m = nM$$

$$m = (0,17)(18,01)$$

$$m = 3,06 \text{ g}$$

2. Sodium azide is a commonly used compound in airbags. When triggered, it has the following reaction:



If 23,4 grams of sodium azide is used, how many moles of nitrogen gas would we expect to produce? What volume would this nitrogen gas occupy at STP?

Solution:

The molar mass of sodium azide is:

$$23,0 + 3(14,0) = 65,0 \text{ g} \cdot \text{mol}^{-1}$$

The number of moles of sodium azide produced is:

$$n = \frac{m}{M}$$

$$n = \frac{23,4}{64,95}$$

$$n = 0,36 \text{ mol}$$

For every two moles of sodium azide we get three moles of nitrogen gas. This gives the number of moles of nitrogen gas:

$$\frac{(0,36)(3)}{2} = 0,54 \text{ mol}$$

At STP one mole of gas would occupy $22,4 \text{ dm}^3$ so 0,54 moles occupies:

$$22,4 \times 0,54 = 12,096 \text{ dm}^3$$

3. Photosynthesis is a chemical reaction that is vital to the existence of life on Earth. During photosynthesis, plants and bacteria convert carbon dioxide gas, liquid water, and light into glucose ($\text{C}_6\text{H}_{12}\text{O}_6$) and oxygen gas.

- Write down the equation for the photosynthesis reaction.
- Balance the equation.
- If 3 mol of carbon dioxide are used up in the photosynthesis reaction, what mass of glucose will be produced?

Solution:

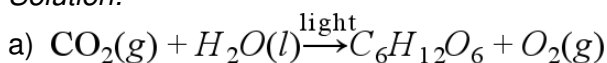

(note that we put light above the arrow indicating that light is needed to make the reaction take place.)

b) We have 6 carbons on the RHS and only 1 on the LHS so we add a 6 in front of the CO_2 : $6\text{CO}_2 + \text{H}_2\text{O} \xrightarrow{\text{light}} \text{C}_6\text{H}_{12}\text{O}_6 + \text{O}_2$

Finally we balance the oxygens. There are 18 on the LHS and 8 on the RHS. We add a 6 in front of the oxygen gas and now the equation is balanced:

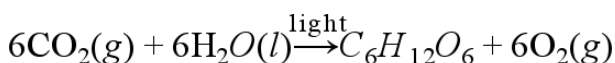

c) From the balanced equation we see that for every 6 moles of carbon dioxide used we get one mole of glucose. So from 3 moles of carbon dioxide we get 0,5 moles of glucose (

$$\frac{3}{6}=0,5).$$

The molar mass of glucose is: $6(12,011) + 12(1,01) + 6(15,99)=180,13\text{g}\cdot\text{mol}^{-1}$

So the mass of glucose produced is:

$$m=nM$$

$$m=(180,13)(0,5)$$

$$m=90,06\text{g}$$

End of chapter exercises:

1. Write only the word/term for each of the following descriptions:

- the mass of one mole of a substance
- the number of particles in one mole of a substance

Solution:

- Molar mass
- Avogadro's number

2. 5 g of magnesium chloride is formed as the product of a chemical reaction. Select the true statement from the answers below:

- 0,08 moles of magnesium chloride are formed in the reaction
- the number of atoms of Cl in the product is $0,6022 \times 10^{23}$
- the atomic ratio of Mg atoms to Cl atoms in the product is 1:1
- the number of atoms of Mg is 0,05

Solution:

- the atomic ratio of Mg atoms to Cl atoms in the product is 1:1

3. 2 moles of oxygen gas react with hydrogen. What is the mass of oxygen in the reactants?

- 32 g
- 64 g
- 0,063 g
- 0,125 g

Solution:

a) 32 g

4. In the compound potassium sulphate (K_2SO_4), oxygen makes up x% of the mass of the compound. x = ...

a) 36,8

b) 4

c) 18,3

d) 9,2

Solution:

a) 36,8

5. The concentration of a 150cm^3 solution, containing 5 g of NaCl is...

a) $0,09\text{ mol} \cdot \text{dm}^{-3}$

b) $5,7 \times 10^{-4}\text{ mol} \cdot \text{dm}^{-3}$

c) $0,57\text{ mol} \cdot \text{dm}^{-3}$

d) $0,03\text{ mol} \cdot \text{dm}^{-3}$

Solution:

c) $0,57\text{ mol} \cdot \text{dm}^{-3}$

6. Calculate the number of moles in:

a) 5 g of methane (CH_4)

b) 3,4 g of hydrochloric acid

c) 4 g of neon

d) 9,6 kg of titanium tetrachloride (TiCl_4)

Solution:

a) The molar mass of methane is $12,011 + 4(1,008) = 16,043\text{ g} \cdot \text{mol}^{-1}$

So the number of moles is:

$$n = \frac{m}{M}$$

$$n = \frac{5}{16,043}$$

$$n = 0,31\text{ mol}$$

b) The molar mass of hydrochloric acid (HCl) is $35,45 + 1,008 = 36,46 \text{ g}\cdot\text{mol}^{-1}$

So the number of moles is:

$$n = \frac{m}{M}$$

$$n = \frac{3,4}{36,46}$$

$$n = 0,09 \text{ mol}$$

c) The molar mass of neon is $20,18 \text{ g}\cdot\text{mol}^{-1}$

So the number of moles is:

$$n = \frac{m}{M}$$

$$n = \frac{4}{20,18}$$

$$n = 0,2 \text{ mol}$$

d) The molar mass of titanium tetrachloride is $47,88 + 4(35,45) = 189,68 \text{ g}\cdot\text{mol}^{-1}$

So the number of moles is:

$$n = \frac{m}{M}$$

$$n = \frac{960}{189,68}$$

$$n = 5,06 \text{ mol}$$

7. Calculate the mass of:

a) 0,2 mol of potassium hydroxide (KOH)

b) 0,47 mol of nitrogen dioxide

c) 5,2 mol of helium

d) 0,05 mol of copper (II) chloride (CuCl_2)

e) $31,31 \times 10^{23}$ molecules of carbon monoxide (CO)

Solution:

a) The molar mass of potassium hydroxide is: $39,09 + 1,008 + 16 = 56,1 \text{ g}\cdot\text{mol}^{-1}$

So the mass is:

$$m = nM$$

$$m = (0,2)(56,1)$$

$$m = 11,2g$$

b) The molar mass of nitrogen dioxide (NO_2) is: $14 + 2(16) = 46g \cdot \text{mol}^{-1}$

So the mass is:

$$m = nM$$

$$m = (0,47)(46)$$

$$m = 21,62g$$

c) The molar mass of helium is $4g \cdot \text{mol}^{-1}$

So the mass is :

$$m = nM$$

$$m = (5,2)(4)$$

$$m = 20,8g$$

d) The molar mass of copper (II) chloride is $63,55 + 2(35,45) = 134,45g \cdot \text{mol}^{-1}$

So the mass is:

$$m = nM$$

$$m = (0,05)(134,45)$$

$$m = 6,72g$$

e) The molar mass of carbon monoxide is $12,011 + 16 = 28,011g \cdot \text{mol}^{-1}$

The number of moles of carbon dioxide is $\frac{31,31 \times 10^{23}}{6,022 \times 10^{23}} = 5,2 \text{ mol}$

So the mass is :

$$m = nM$$

$$m = (5,2)(28,011)$$

$$m=145,66\text{g}$$

8. Calculate the percentage that each element contributes to the overall mass of:

a) Chloro-benzene (C_6H_5Cl)

b) Lithium hydroxide ($LiOH$)

Solution:

a) The molar mass is: $112,56\text{g}\cdot\text{mol}^{-1}$

For each element we get:

$$\text{Cl: } \frac{35,45}{112,56} \times 100 = 31,49\%$$

$$\text{C: } \frac{72,07}{112,56} \times 100 = 64,02\%$$

$$\text{H: } \frac{5,04}{112,56} \times 100 = 4,48\%$$

b) The formula mass of $LiOH$ is $24\text{g}\cdot\text{mol}^{-1}$

For each element we get:

$$\text{Li: } \frac{7}{24} \times 100 = 29,17\%$$

$$\text{O: } \frac{16}{24} \times 100 = 66,67\%$$

$$\text{H: } \frac{1}{24} \times 100 = 4,17\%$$

9. CFC's (chlorofluorocarbons) are one of the gases that contribute to the depletion of the ozone layer. A chemist analysed a CFC and found that it contained 58,64% chlorine, 31,43% fluorine and 9,93% carbon. What is the empirical formula?

Solution:

We assume that we have 100 g of compound. So the mass of each element is: Cl: 58,64 g ; F: 31,43 g and C: 9,93 g.

Next we find the number of moles of each element:

$$\text{Cl: } n = \frac{m}{M} = \frac{58,64}{35,45} = 1,65$$

$$\text{F: } n = \frac{m}{M} = \frac{31,43}{19} = 1,65$$

$$\text{C: } n = \frac{m}{M} = \frac{9,93}{12,011} = 0,77$$

Dividing by the smallest number (0,77) gives:

Cl: 2 ; F: 2 ; C: 1

So the empirical formula is: CF_2Cl_2

10. 14 g of nitrogen combines with oxygen to form 46 g of a nitrogen oxide. Use this information to work out the formula of the oxide.

Solution:

We first calculate the mass of oxygen in the reactants:

$$46 - 14 = 32 \text{ g.}$$

Next we calculate the number of moles of nitrogen and oxygen in the reactants:

$$\text{Nitrogen: } n = \frac{m}{M} = \frac{14}{14} = 1$$

$$\text{Oxygen: } n = \frac{m}{M} = \frac{32}{16} = 2$$

So the formula of the oxide is: NO_2 .

11. Iodine can exist as one of three oxides (I_2O_4 ; I_2O_5 ; I_4O_9). A chemist has produced one of these oxides and wishes to know which one they have. If he started with 508 g of iodine and formed 652 g of the oxide, which oxide has he produced?

Solution:

We first calculate the mass of oxygen in the reactants:

$$652 - 508 = 144 \text{ g}$$

Next we calculate the number of moles of iodine and oxygen in the reactants:

$$I: n = \frac{m}{M} = \frac{508}{127} = 4$$

$$O: n = \frac{m}{M} = \frac{144}{16} = 9$$

So he has produced I_4O_9

12. A fluorinated hydrocarbon (a hydrocarbon is a chemical compound containing hydrogen and carbon) was analysed and found to contain 8,57% H, 51,05% C and 40,38% F.

a) What is its empirical formula?

b) What is the molecular formula if the molar mass is $94,1 \text{ g} \cdot \text{mol}^{-1}$?

Solution:

a) We assume that there is 100 g of the compound. So in 100 g, we would have 8,57 g H, 51,05 g C and 40,38 g F.

Next we find the number of moles of each element:

$$H: n = \frac{m}{M} = \frac{8,57}{1,008} = 8,5 \text{ mol}$$

$$C: n = \frac{m}{M} = \frac{51,05}{12,011} = 4,3 \text{ mol}$$

$$F: n = \frac{m}{M} = \frac{40,38}{19} = 2,1 \text{ mol}$$

Now we divide this by the smallest number of moles, which is 2,1:

H: 4 C: 2 F: 1

Therefore the empirical formula is: C_2H_4F

b) The molar mass of the empirical formula is $47,05 \text{ g} \cdot \text{mol}^{-1}$. Therefore we must double the number of moles of each element to get the molecular formula. The molecular formula is: $C_4H_8F_2$

13. Copper sulphate crystals often include water. A chemist is trying to determine the number of moles of water in the copper sulphate crystals. She weighs out 3 g of copper sulphate and heats this. After heating, she finds that the mass is 1,9 g. What is the number of moles of water in the crystals? (Copper sulphate is represented by $\text{CuSO}_4 \cdot x\text{H}_2\text{O}$).

Solution:

We first work out how many water molecules are lost:

$$3\text{g} - 1,9\text{g} = 1,1\text{g}$$

The mass ratio of copper sulphate to water is:

$$1,9\text{g} : 1,1\text{g}$$

Now we divide this by the molar mass of each species. CuSO_4 has a molar mass of $159,55\text{g}\cdot\text{mol}^{-1}$ and water has a molar mass of $18\text{g}\cdot\text{mol}^{-1}$.

So the mole ratio is:

$$\frac{1,9}{159,55} : \frac{1,1}{18}$$

$$0,012 : 0,06$$

Dividing both of these numbers by 0,012 we find that the number of water molecules is 5. So the formula for copper sulphate is: $\text{CuSO}_4 \cdot 5\text{H}_2\text{O}$

14. 300cm^3 of a $0,1\text{mol}\cdot\text{dm}^{-3}$ solution of sulphuric acid is added to 200cm^3 of a $0,5\text{mol}\cdot\text{dm}^{-3}$ solution of sodium hydroxide.

- Write down a balanced equation for the reaction which takes place when these two solutions are mixed.
- Calculate the number of moles of sulphuric acid which were added to the sodium hydroxide solution.
- Is the number of moles of sulphuric acid enough to fully neutralise the sodium hydroxide solution? Support your answer by showing all relevant calculations.

Solution:

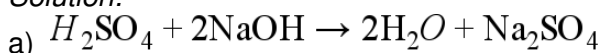

b) We first convert the volume to dm^3 :

$$\frac{300}{1000} = 0,3 \text{dm}^3$$

$$n = cV$$

$$n = (0,3)(0,1)$$

$$n = 0,03 \text{mol}$$

c) The number of moles of sodium hydroxide used is:

$$n = cV$$

$$n = (0,5)(0,2)$$

$$n = 0,1 \text{mol}$$

The molar ratio of sulphuric acid to sodium hydroxide is 1:2

So we need twice the number of moles of sulphuric acid (i.e. $0,1 \times 2 = 0,2$) to neutralise the sodium hydroxide. The number of moles of sulphuric acid is more than twice the number of moles of sodium hydroxide and so the the number of moles added is enough to fully neutralise the sodium hydroxide.

15. A learner is asked to make 200cm^3 of sodium hydroxide (NaOH) solution of concentration $0,5\text{mol}\cdot\text{dm}^{-3}$.

- Determine the mass of sodium hydroxide pellets he needs to use to do this.
- Using an accurate balance the learner accurately measures the correct mass of the NaOH pellets. To the pellets he now adds exactly 200cm^3 of pure water. Will his solution have the correct concentration? Explain your answer.
- The learner then takes 300cm^3 of a $0,1\text{mol}\cdot\text{dm}^{-3}$ solution of sulphuric acid (H_2SO_4) and adds it to 200cm^3 of a $0,5\text{mol}\cdot\text{dm}^{-3}$ solution of NaOH at 25°C .
- Write down a balanced equation for the reaction which takes place when these two solutions are mixed.
- Calculate the number of moles of H_2SO_4 which were added to the NaOH solution.

Solution:

a) We first convert the volume to dm^3

$$\frac{200}{1000} = 0,2 \text{ dm}^3$$

The number of moles is:

$$n = cV$$

$$n = (0,2)(0,5)$$

$$n = 0,1 \text{ mol}$$

The molar mass of NaOH is:

$$22,99 + 16,00 + 1,01 = 40 \text{ g} \cdot \text{mol}^{-1}$$

And the mass of NaOH needed is:

$$m = nM$$

$$m = (0,1)(40)$$

$$m = 4 \text{ g}$$

b) The concentration will be incorrect. The volume will change slightly when the pellets dissolve in the solution. The learner should have first dissolved the pellets and then made the volume up to the correct amount.

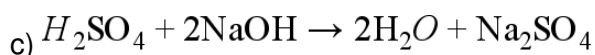

$$\text{d) } n = cV$$

$$n = (0,5)(0,2)$$

$$n = 0,1 \text{ mol}$$

e) No. The number of moles of H_2SO_4 needs to be twice the number of moles of NaOH as the molar ratio is 1:2.

16. 96, 2 g sulphur reacts with an unknown quantity of zinc according to the following equation:

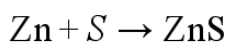

- a) What mass of zinc will you need for the reaction, if all the sulphur is to be used up?
b) Calculate the theoretical yield for this reaction.
c) It is found that 275 g of zinc sulphide was produced. Calculate the % yield.

Solution:

a) We first calculate the number of moles of sulphur:

Molar mass sulphur: $32,06 \text{ g} \cdot \text{mol}^{-1}$

$$n = \frac{m}{M}$$

$$n = \frac{96,2}{32,06}$$

$$n = 3,00 \text{ mol}$$

The molar ratio of sulphur to zinc is 1:1 so this is also the number of moles of zinc that must be added to use up all the sulphur.

The mass of zinc is therefore:

$$m = nM$$

$$m = (3)(65,38)$$

$$m = 196,14 \text{ g}$$

b) We can use either the moles of zinc or the moles of sulphur to determine the moles of zinc sulphide.

The molar ratio of sulphur to zinc sulphide is 1:1, so the number of moles of zinc sulphide is 3 mol.

The mass is:

$$\begin{aligned} m &= nM \\ m &= (3)(65,38 + 32,06) \\ m &= (3)(97,44) \\ m &= 292,32 \text{ g} \end{aligned}$$

$$\text{c) } \% \text{ yield} = \frac{\text{actual yield}}{\text{theoretical yield}} \times 100 = \frac{275}{292,32} \times 100 = 94,1 \%$$

17. Calcium chloride reacts with carbonic acid to produce calcium carbonate and hydrochloric acid according to the following equation:

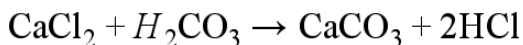

If you want to produce 10 g of calcium carbonate through this chemical reaction, what quantity (in g) of calcium chloride will you need at the start of the reaction?

Solution:

Molar mass of CaCO_3 :

$$40,08 + 12,01 + 3(16,00) = 100,09 \text{ g} \cdot \text{mol}^{-1}$$

Number of moles of CaCO_3 :

$$n = \frac{m}{M}$$

$$n = \frac{10}{100,09}$$

$$n = 0,10 \text{ mol}$$

The molar ratio of calcium carbonate to calcium chloride is 1:1, so the number of moles of calcium chloride is 0,10 moles.

The mass of calcium chloride needed is therefore:

$$m = nM$$

$$m = (0,10)(40,08 + 2(35,45))$$

$$m = (0,10)(110,98)$$

$$m = 11,098 \text{ g}$$

Chapter 20. Vectors and scalars

Exercise 20-1:

Classify the following as vectors or scalars:

1. length
2. force
3. direction
4. height
5. time
6. speed
7. temperature

Solution:

1. scalar
2. vector
3. scalar
4. scalar
5. scalar
6. scalar
7. scalar

Exercise 20-2:

1. Classify the following quantities as scalars or vectors:

- a) 12 km
- b) 1 m south
- c) $2 \text{ m}\cdot\text{s}^{-1}, 45^\circ$
- d) $075^\circ, 2 \text{ cm}$
- e) $100 \text{ km}\cdot\text{h}^{-1}, 0^\circ$

Solution:

- a) scalar
- b) vector
- c) vector

- d)vector
- e)vector

2. Use two different notations to write down the direction of the vector in each of the following diagrams

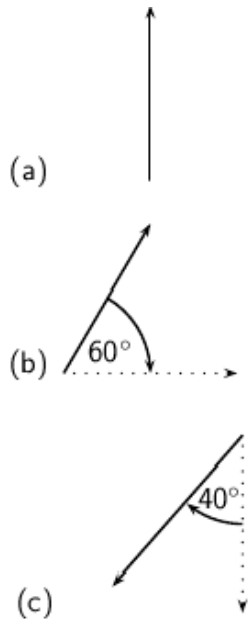

Solution:

- a) *north*; 000° ; 360°
- b) $E\ 60^\circ\ N$, $N\ 30^\circ\ E$; 090°
- c) $S\ 40^\circ\ W$, $W\ 50^\circ\ S$; 220°

Exercise 20-3:

Draw each of the following vectors to scale. Indicate the scale that you have used:

1. 12 km south
2. $1,5\ m\ N\ 45^\circ\ W$
3. $1\ m.s^{-1}$, 20° East of North
4. $50\ km.h^{-1}$, 085°
5. $5\ mm$, 225°

Solution:

NOTE: The diagrams shown are not drawn to scale.

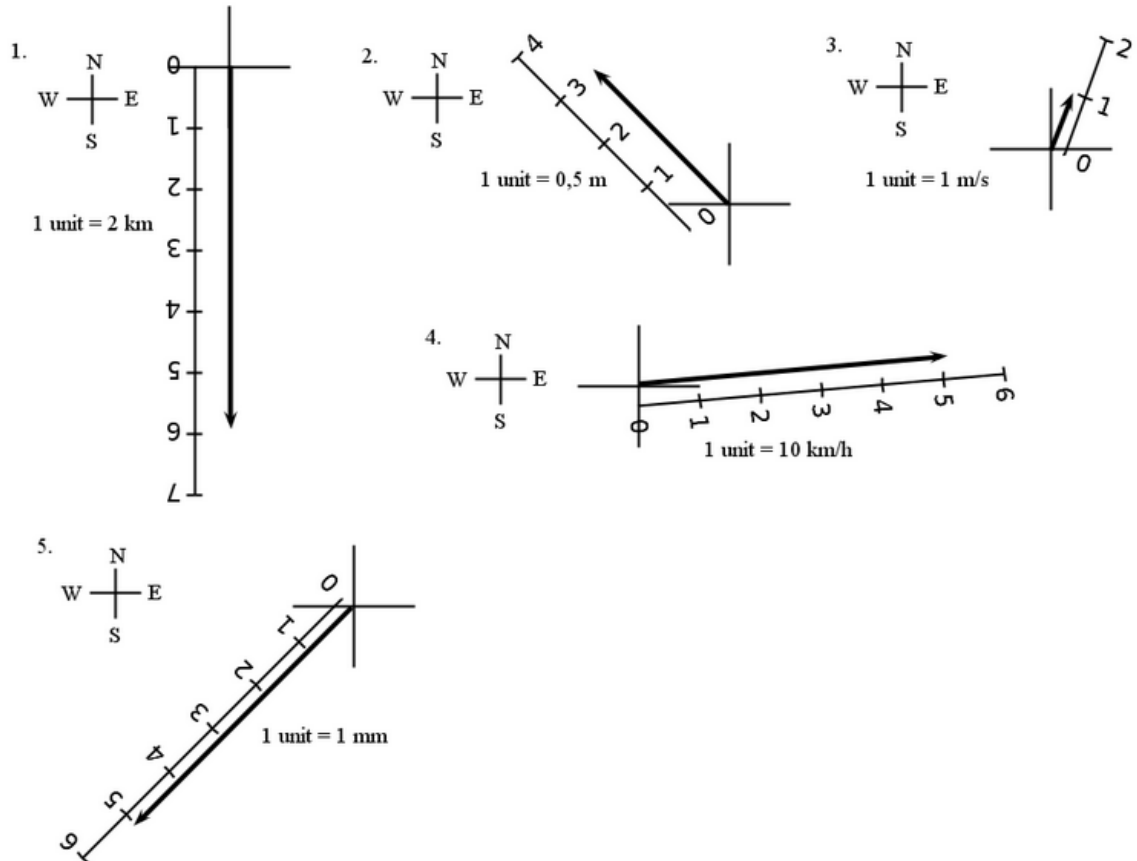

Exercise 20-4:

1. Harold walks to school by walking 600 m Northeast and then 500 m N 40° W. Determine his resultant displacement by using accurate scale drawings.

Solution:

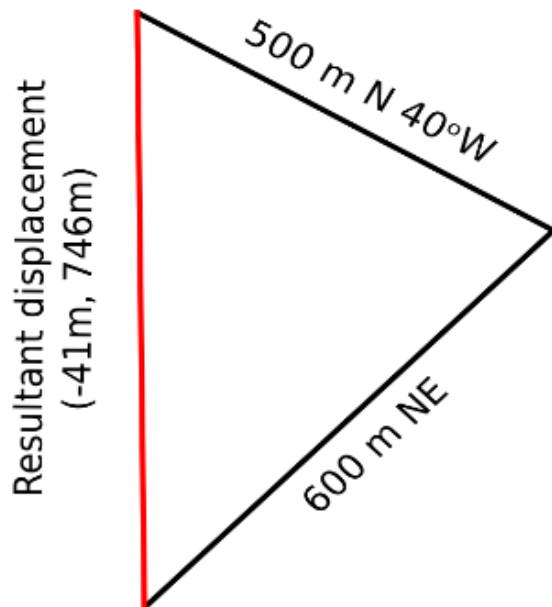

2. A dove flies from her nest, looking for food for her chick. She flies at a velocity of 2 m s^{-1} on a bearing of 135° and then at a velocity of $1,2 \text{ m s}^{-1}$ on a bearing of 230° . Calculate her resultant velocity by using accurate scale drawings.

Solution:

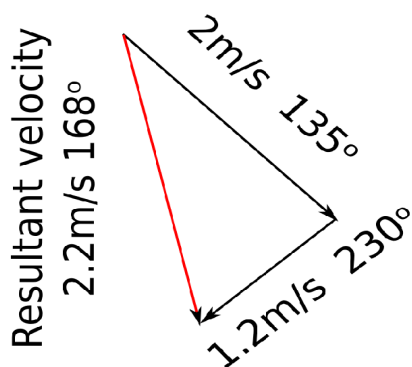

3. A squash ball is dropped to the floor with an initial velocity of $2,5 \text{ m}\cdot\text{s}^{-1}$. It rebounds (comes back up) with a velocity of $0,5 \text{ m}\cdot\text{s}^{-1}$.

a) What is the change in velocity of the squash ball?

b) What is the resultant velocity of the squash ball?

Solution:

NOTE: The diagrams shown are not drawn to scale.

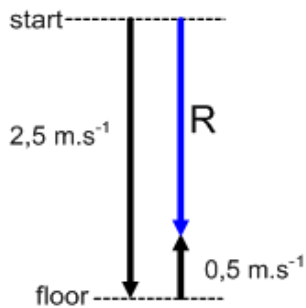

Positive direction towards the floor. This means that the negative direction is away from the floor.

a)

$$v_i = +2.5 \text{ m.s}^{-1}$$

$$v_f = -0.5 \text{ m.s}^{-1}$$

$$\Delta \vec{v} = v_f - v_i$$

$$\Delta \vec{v} = (-0.5 \text{ m.s}^{-1}) - (+2.5 \text{ m.s}^{-1})$$

$$\Delta \vec{v} = (-3) \text{ m.s}^{-1}$$

Thus: $\Delta \vec{v} = 3 \text{ m.s}^{-1}$, away from the floor

b) Resultant; $v = 2 \text{ m.s}^{-1}$, towards the floor

4. A frog is trying to cross a river. It swims at 3 m.s^{-1} in a northerly direction towards the opposite bank. The water is flowing in a westerly direction at 5 m.s^{-1} . Find the frog's resultant velocity by using appropriate calculations. Include a rough sketch of the situation in your answer.

Solution:

NOTE: The rough sketch shown is not drawn to scale.

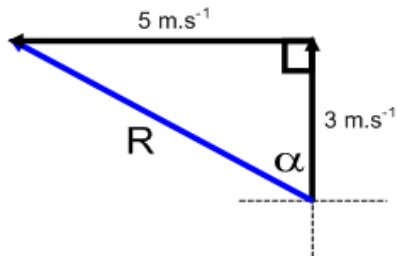

$$x_R^2 = 3^2 + 5^2$$

$$x_R^2 = 36$$

$$x_R = 6 \text{ m.s}^{-1}$$

$$\tan(\alpha) = \frac{\text{opposite}}{\text{adjacent side}}$$

$$\tan(\alpha) = \frac{5}{3}$$

$$\alpha = \tan^{-1} \frac{5}{3}$$

$$\alpha = 59^\circ$$

The frog's resultant velocity is 6 m.s^{-1} at a bearing of 301° (or $N 59^\circ W$)

5. Mphlonhle walks to the shop by walking 500 m Northwest and then 400 m $N 30^\circ E$. Determine her resultant displacement by doing appropriate calculations.

Solution:

NOTE: The rough sketch shown is not drawn to scale.

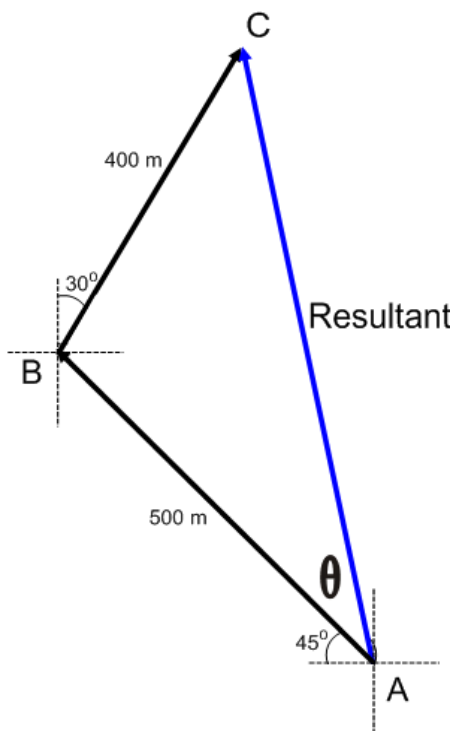

$$AC^2 = AB^2 + BC^2 - 2 \cdot AB \cdot BC \cos \hat{A}BC$$

$$AC^2 = 500^2 + 400^2 - (2)(500)(400)\cos 105^\circ$$

$$AC = 716.6 \text{ m}$$

$$\frac{\sin \theta}{400} = \frac{\sin 105^\circ}{716.6}$$

$$\theta = \sin^{-1}(0,53917)$$

$$\theta = 32,6^\circ$$

Her resultant displacement is therefore 716.6 m on a bearing 347.6°

Exercise 20-5:

1. Harold walks to school by walking 600 m Northeast and then 500 m N 40° W. Determine his resultant displacement by means of addition of components of vectors.

Solution:

NOTE: The rough sketch shown is not drawn to scale.

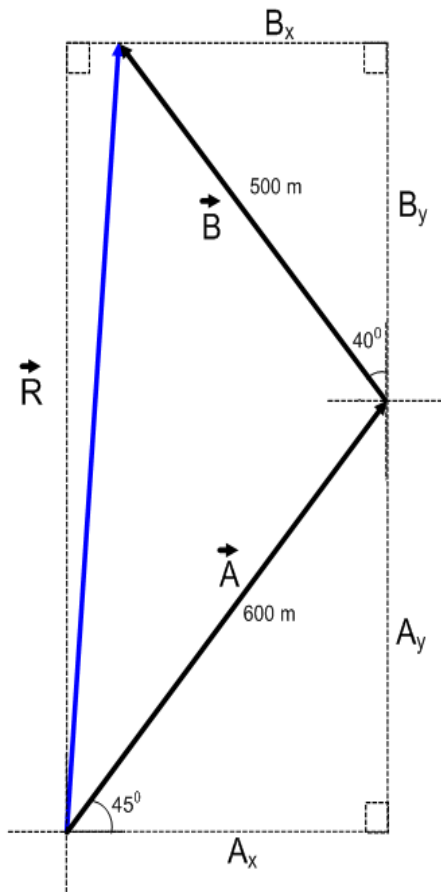

Resolving $\rightarrow A$ into components:

Vertical component A_y :

$$\sin \theta = \frac{A_y}{A}$$

$$\sin 45^\circ = \frac{A_y}{600}$$

$$A_y = (600)(\sin 45^\circ)$$

$$= 424.26 \text{ m}$$

Horizontal component A_x :

$$\begin{aligned}\cos \theta &= \frac{A_x}{A} \\ \cos 45^\circ &= \frac{A_y}{600} \\ A_y &= (600)(\cos 45^\circ) \\ &= 424.26 \text{ m}\end{aligned}$$

Resolving $\rightarrow B$ into components:

Vertical component B_y :

$$\begin{aligned}\sin \theta &= \frac{B_y}{B} \\ \sin 50^\circ &= \frac{B_y}{500} \\ B_y &= (500)(\sin 50^\circ) \\ &= 383.02 \text{ m}\end{aligned}$$

Horizontal component B_x :

$$\begin{aligned}\cos \theta &= \frac{B_x}{B} \\ \cos 50^\circ &= \frac{B_x}{500} \\ B_x &= (500)(\cos 50^\circ) \\ &= 321.39 \text{ m}\end{aligned}$$

Components of resultants, R

$$\begin{aligned}R_x &= A_x + B_x \\ &= 424.26 + (-383.02) \\ &= 41.24 \text{ m}\end{aligned}$$

$$\begin{aligned}R_y &= A_y + B_y \\ &= 424.26 + 321.39 \\ &= 745.65 \text{ m}\end{aligned}$$

$$R^2 = R_x^2 + R_y^2$$

$$R^2 = 41.24^2 + 745.65^2$$

$$R = 746.79 \text{ m}$$

Angle of resultant

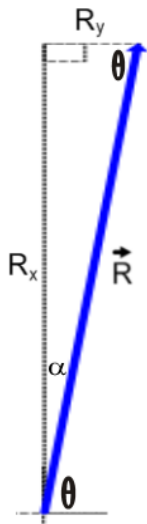

$$\tan \theta = \frac{R_y}{R_x}$$

$$\tan \theta = 745. \frac{65}{41} .24$$

$$\theta = \tan^{-1} \frac{745.65}{41} .24$$

$$\theta = 86.83^\circ$$

Therefore, $R = 746.79 \text{ m}$ at an angle of 86.83° to the horizontal

2. A dove flies from her nest, looking for food for her chick. She flies at a velocity of $2 \text{ m} \cdot \text{s}^{-1}$ on a bearing of 135° and then at a velocity of $1.2 \text{ m} \cdot \text{s}^{-1}$ on a bearing of 230° . Calculate her resultant velocity by adding the horizontal and vertical components of vectors.

Solution:

$$\begin{aligned}v_x &= 2\cos(45^\circ) - 1.2\cos(50^\circ) \\ &= 0,6 \text{ m}\cdot\text{s}^{-1} \\ v_y &= -2\sin(45^\circ) - 1.2\sin(130^\circ) \\ &= -2,3 \text{ m}\cdot\text{s}^{-1} \\ v_{res2} &= vx^2 + vy^2 \\ &= (0,64)^2 + (-2,3)^2 \\ v_{res} &= 2,4 \text{ m}\cdot\text{s}^{-1} \\ \sin(\theta) &= (0,6)(2,4) \\ \theta &= \text{S } 15^\circ \text{ E} \\ v_{res} &= 2,4 \text{ m}\cdot\text{s}^{-1} \text{ S } 15^\circ \text{ E}\end{aligned}$$

End of chapter exercises:

1. A point is acted on by two forces in equilibrium. The forces

- a) have equal magnitudes and directions.
- b) have equal magnitudes but opposite directions.
- c) act perpendicular to each other.
- d) act in the same direction.

Solution:

b) have equal magnitudes but opposite directions.

2. Which of the following contains two vectors and a scalar?

- a) distance, acceleration, speed
- b) displacement, velocity, acceleration
- c) distance, mass, speed
- d) displacement, speed, velocity

Solution:

d) displacement, speed, velocity

3. Two vectors act on the same point. What should the angle between them be so that a maximum resultant is obtained?

- a) 0°
- b) 90°

- c) 180°
- d) cannot tell

Solution:

- a) 0°

4. Two forces, 4 N and 11 N, act on a point. Which one of the following cannot be the magnitude of a resultant?

- a) 4 N
- b) 7 N
- c) 11 N
- d) 15 N

Solution:

- a) 4N

Chapter 21. Motion in one dimension

Exercise 21-1:

1. Write down the position for objects at A, B, D and E. Do not forget the units.

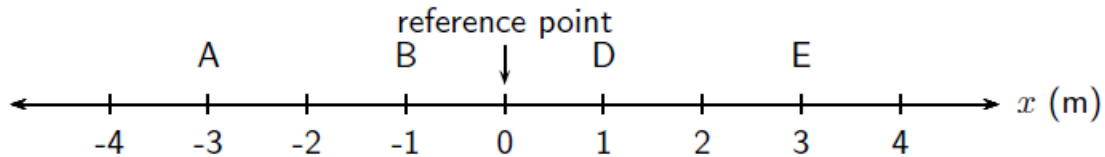

Solution:

A is at -3 m, B is at -1 m, D is at 1 m and E is at 3 m.

2. Write down the position for objects at F, G, H and J. Do not forget the units.

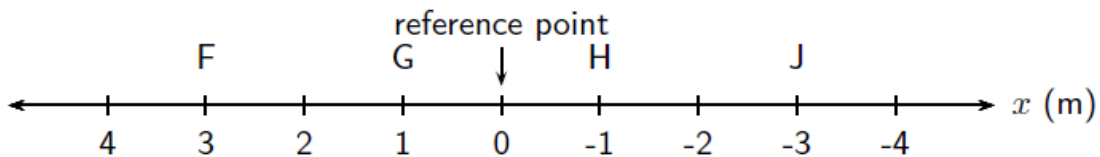

Solution:

F is at 3 m, G is at 1 m, H is at -1 m and J is at -3 m.

3. There are five houses on Newton Street, A, B, C, D, and E. For all cases, assume that positions to the right are positive.

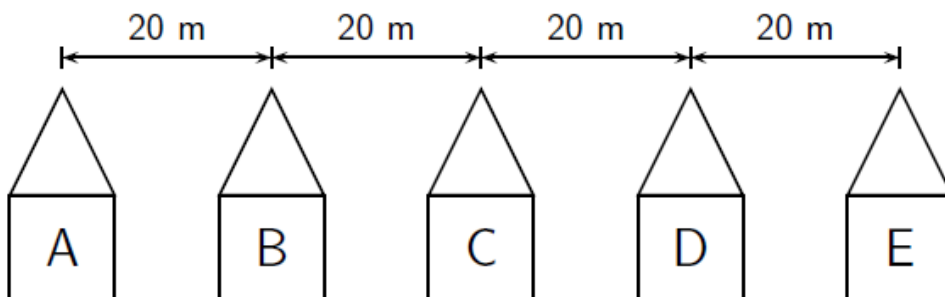

a) Draw a frame of reference with house A as the origin and write down the positions of

houses B, C, D and E.

b) You live in house C. What is your position relative to house E?

c) What are the positions of houses A, B and D, if house B is taken as the reference point?

Solution:

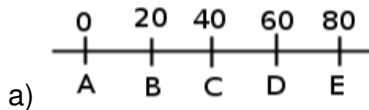

b) House E is -40 m away.

c) A is at -10 m, D is at 40 m and B is at 0 m.

Exercise 21-2:

1. Use the following figure to answer the questions.

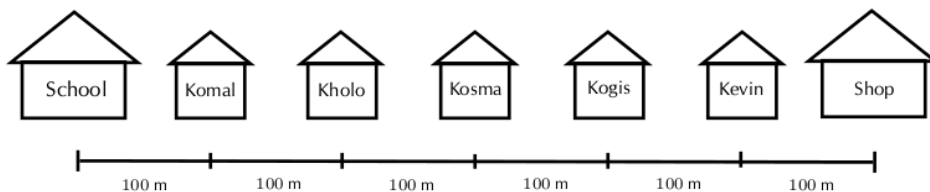

a) Kogis walks to Kosma's house and then to school, what is her distance and displacement?

b) Kholo walks to Kosma's house and then to school, what is her distance and displacement?

c) Komal walks to the shop and then to school, what is his distance and displacement?

d) What reference point did you use for each of the above questions?

Solution:

a) Her distance is 400 m and her displacement is $-(100) + (-300) = -400m$

b) Her distance is 400 m and her displacement is $-200m$

c) His distance is 1 100 m and his displacement is $+500 + (-600) = -100m$

d) For a) we used Kosma's house as the point of reference, for b) we used Kholo's house as the point of reference and for c) we used Komal's house as the point of reference.

2. You stand at the front door of your house (displacement, $\Delta \vec{x} = 0m$). The street is 10

m away from the front door. You walk to the street and back again.

- What is the distance you have walked?
- What is your final displacement?
- Is displacement a vector or a scalar? Give a reason for your answer.

Solution:

- 20 m.
- Your final displacement is 0m. You have returned to your starting point.
- Vector since it has a direction and magnitude.

Exercise 21-3:

1. Bongani has to walk to the shop to buy some milk. After walking 100 m, he realises that he does not have enough money, and goes back home.

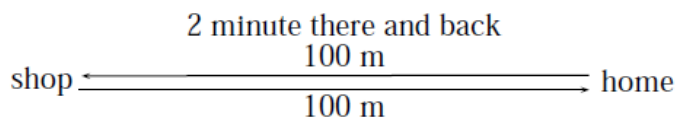

If it took him two minutes to leave and come back, calculate the following:

- How long was he out of the house (the time interval Δt in seconds)?
- How far did he walk (distance (D))?
- What was his displacement ($\Delta \vec{x}$)?
- What was her average velocity (in $m \cdot s^{-1}$)?
- What was his average speed (in $m \cdot s^{-1}$)?

Solution:

- 120 seconds.
- 200 m.
- 0
- The velocity is the total displacement over the total time and so the velocity is 0.

$$v = \frac{0}{60} = 0 m \cdot s^{-1}$$

e) The speed is the total distance travelled divided by the total time taken:

$$\text{speed} = \frac{200}{120} = 1,67 m \cdot s^{-1}$$

2. Bridget is watching a straight stretch of road from her classroom window. She can see two poles which she earlier measured to be 50 m apart. Using her stopwatch, Bridget notices that it takes 3 s for most cars to travel from the one pole to the other.

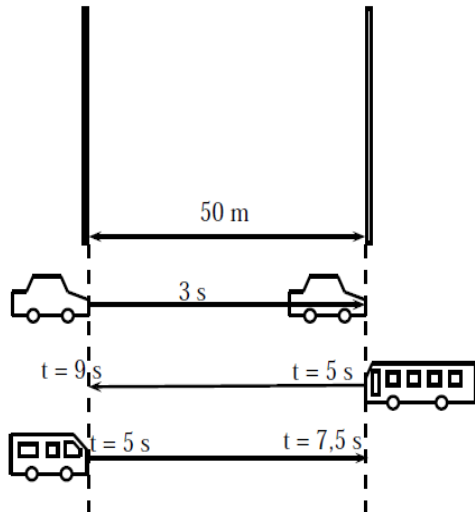

a) Using the equation for velocity ($\vec{v}_{\text{av}} = \frac{\Delta \vec{x}}{\Delta t}$), show all the working needed to calculate the velocity of a car travelling from the left to the right.

b) If Bridget measures the velocity of a red Golf to be $-16,67\text{ m}\cdot\text{s}^{-1}$, in which direction was the Golf travelling? Bridget leaves her stopwatch running, and notices that at $t = 5,0\text{ s}$, a taxi passes the left pole at the same time as a bus passes the right pole. At time $t = 7,5\text{ s}$ the taxi passes the right pole. At time $t = 9,0\text{ s}$, the bus passes the left pole.

c) How long did it take the taxi and the bus to travel the distance between the poles? (Calculate the time interval (Δt) for both the taxi and the bus).

d) What was the average velocity of the taxi and the bus?

e) What was the average speed of the taxi and the bus?

f) What was the average speed of taxi and the bus in $\text{km}\cdot\text{h}^{-1}$?

Solution:

a) We choose a frame of reference. E.g. from the left pole to the right pole is the positive direction. The displacement (Δx) for a car is 50 m and the time taken (Δt) is 3 s.

Then the velocity for a car travelling from left to right is: $v = \frac{\Delta x}{\Delta t} = \frac{50}{3} = 16,67\text{ m}\cdot\text{s}^{-1}$

b) The direction depends on which convention was taken as the positive direction. If the direction from the left pole to the right pole is taken as the positive direction then the car is travelling from the right pole to the left pole.

c) Taxi: $\Delta t = t_f - t_i = 7,5 - 5 = 2,5 \text{ s}$

Bus: $\Delta t = t_f - t_i = 9 - 5 = 4 \text{ s}$

d) Taxi: $v = \frac{\Delta x}{\Delta t} = \frac{50}{2,5} = 20 \text{ m} \cdot \text{s}^{-1}$

Bus: $v = \frac{\Delta x}{\Delta t} = \frac{-50}{4} = -12,5 \text{ m} \cdot \text{s}^{-1}$

e) Taxi: $20 \text{ m} \cdot \text{s}^{-1}$

Bus: $12,5 \text{ m} \cdot \text{s}^{-1}$

f) Taxi: $s = \frac{20 \text{ m}}{1 \text{ s}} \times \frac{1 \text{ km}}{1000 \text{ m}} \times \frac{60 \text{ s}}{1 \text{ min}} \times \frac{60 \text{ min}}{1 \text{ hr}} = 72 \text{ km} \cdot \text{hr}^{-1}$

Bus: $s = \frac{12,5 \text{ m}}{1 \text{ sec}} \times \frac{1 \text{ km}}{1000 \text{ m}} \times \frac{60 \text{ sec}}{1 \text{ min}} \times \frac{60 \text{ min}}{1 \text{ hr}} = 45 \text{ km} \cdot \text{hr}^{-1}$

3. A rabbit runs across a freeway. There is a car 100 m away travelling towards the rabbit.

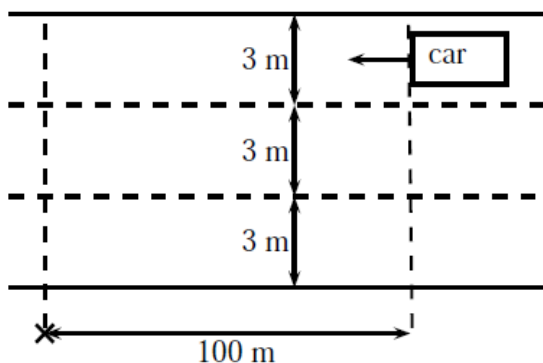

a) If the car is travelling at $120 \text{ km} \cdot \text{h}^{-1}$, what is the car's speed in $\text{m} \cdot \text{s}^{-1}$.

b) How long will it take the a car to travel 100 m?

c) If the rabbit is running at $10 \text{ km} \cdot \text{h}^{-1}$, what is its speed in $\text{m} \cdot \text{s}^{-1}$?

d) If the freeway has 3 lanes, and each lane is 3 m wide, how long will it take for the rabbit to cross all three lanes?

e) If the car is travelling in the furthestmost lane from the man, will the rabbit be able to cross all 3 lanes of the freeway safely?

Solution:

a) 1 km = 1 000 m and 1 hour = 60 seconds.

$$\frac{120\text{km}}{1\text{hour}} \times \frac{1000\text{m}}{1\text{km}} \times \frac{1\text{hr}}{60\text{min}} \times \frac{1\text{min}}{60\text{sec}} = 33,33\text{m}\cdot\text{s}^{-1}$$

b) $\frac{100\text{m}}{33,33\text{m}\cdot\text{s}^{-1}} = 3,00\text{s}$

c) $\frac{10\text{km}}{1\text{hour}} \times \frac{1000\text{m}}{1\text{km}} \times \frac{1\text{hr}}{60\text{min}} \times \frac{1\text{min}}{60\text{sec}} = \frac{10000}{3600} = 2,78\text{m}\cdot\text{s}^{-1}$

d) The rabbit has to cover a total distance of 9 m. (3 times 3)

The time it will take the rabbit is: $\frac{9\text{m}}{2,78\text{m}\cdot\text{s}^{-1}} = 3,24\text{s}$

e) Although the rabbit will take slightly longer than the car to cross the freeway, the rabbit will reach the far lane in $\frac{6}{2,78} = 2,14\text{s}$ and so in the time it takes to cross the final lane the car will hit the rabbit.

Exercise 21-4:

1. An athlete is accelerating uniformly from an initial velocity of $0\text{m}\cdot\text{s}^{-1}$ to a final velocity of $4\text{m}\cdot\text{s}^{-1}$ in 2 seconds. Calculate his acceleration. Let the direction that the athlete is running in be the positive direction.

Solution:

$$a = \frac{\Delta v}{\Delta t}$$

$$a = \frac{4-0}{2-0}$$

$$a = 2\text{m}\cdot\text{s}^{-2}$$

2. A bus accelerates uniformly from an initial velocity of $15m \cdot s^{-1}$ to a final velocity of $7m \cdot s^{-1}$ in 4 seconds. Calculate the acceleration of the bus. Let the direction of motion of the bus be the positive direction.

Solution:

$$a = \frac{\Delta v}{\Delta t}$$

$$a = \frac{7-15}{4-0}$$

$$a = -2m \cdot s^{-2}$$

3. An aeroplane accelerates uniformly from an initial velocity of $100m \cdot s^{-1}$ to a velocity of $200m \cdot s^{-1}$ in 10 seconds. It then accelerates uniformly to a final velocity of $240m \cdot s^{-1}$ in 20 seconds. Let the direction of motion of the aeroplane be the positive direction.

- Calculate the acceleration of the aeroplane during the first 10 seconds of the motion.
- Calculate the acceleration of the aeroplane during the next 20 seconds of its motion.

Solution:

a) $a = \frac{\Delta v}{\Delta t}$

$$a = \frac{200-100}{10-0}$$

$$a = 10m \cdot s^{-2}$$

b) $a = \frac{\Delta v}{\Delta t}$

$$a = \frac{240-200}{30-10}$$

$$a = 2m \cdot s^{-2}$$

Exercise 21-5:

- Use the graphs to calculate each of the following:

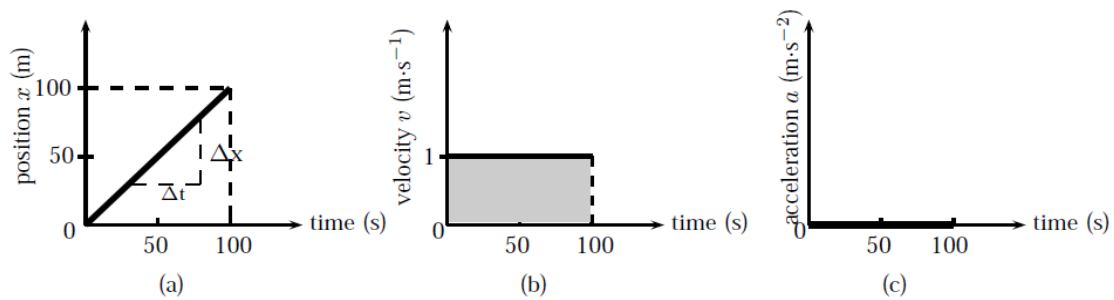

- a) Calculate Vivian's velocity between 50 s and 100 s using the x vs. t graph. Hint: Find the gradient of the line.
- b) Calculate Vivian's acceleration during the whole motion using the v vs. t graph.
- c) Calculate Vivian's displacement during the whole motion using the v vs. t graph.

Solution:

a) The gradient of the line is:

$$m = \frac{y_2 - y_1}{x_2 - x_1}$$

$$m = \frac{100 - 0}{100 - 0}$$

$$m = \frac{100}{100}$$

$$m = 1$$

The gradient is the velocity and so the velocity is: $1 \text{ m} \cdot \text{s}^{-1}$

Looking at the velocity-time graph we see that this is indeed the velocity that we expected.

b) The acceleration is the gradient of the velocity-time graph and so the acceleration is:

$$m = \frac{y_2 - y_1}{x_2 - x_1}$$

$$m = \frac{1 - 1}{100 - 0}$$

$$m = 0$$

This gives the acceleration as: $0 \text{ m} \cdot \text{s}^{-2}$

And if we look at the acceleration-time graph we see that the acceleration is 0.

c) To get the displacement we calculate the area under the velocity-time graph. The area is a rectangle with length 100 and breadth 1, so the area is:

$$\text{Area} = 1 \text{ m} \cdot \text{s}^{-1} \times 100 \text{ s} = 100 \text{ m}$$

The displacement is 100 m

2. Thandi takes 200 s to walk 100 m to the bus stop every morning. In the evening Thandi takes 200 s to walk 100 m from the bus stop to her home.

a) Draw a graph of Thandi's position as a function of time for the morning (assuming that Thandi's home is the reference point). Use the gradient of the x vs. t graph to draw the graph of velocity vs. time. Use the gradient of the v vs. t graph to draw the graph of acceleration vs. time.

b) Draw a graph of Thandi's position as a function of time for the evening (assuming that Thandi's home is the origin). Use the gradient of the x vs. t graph to draw the graph of velocity vs. time. Use the gradient of the v vs. t graph to draw the graph of acceleration vs. time.

c) Discuss the differences between the two sets of graphs in questions 2 and 3.

Solution:

a) The gradient of the position-time graph is: $m = \frac{100-0}{200-0} = 0,5$. This gives the velocity-time graph. Since the motion is at constant velocity, the gradient of the velocity-time graph is 0 and so the acceleration is 0.

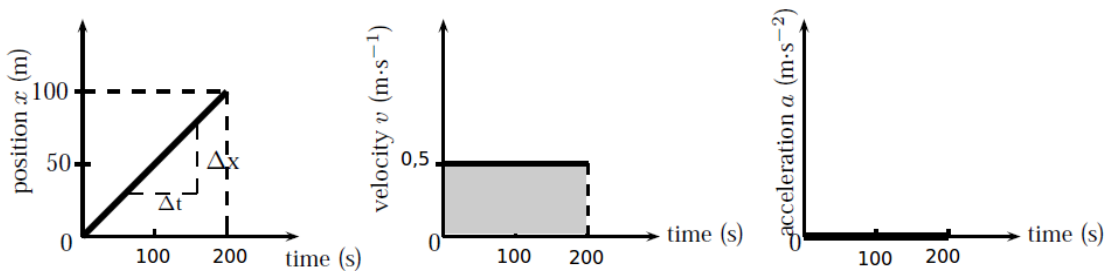

b) The gradient of the position-time graph is: $m = \frac{100-0}{0-200} = -0,5$. This gives the velocity-time graph. Since the motion is at constant velocity, the gradient of the velocity-time graph is 0 and so the acceleration is 0.

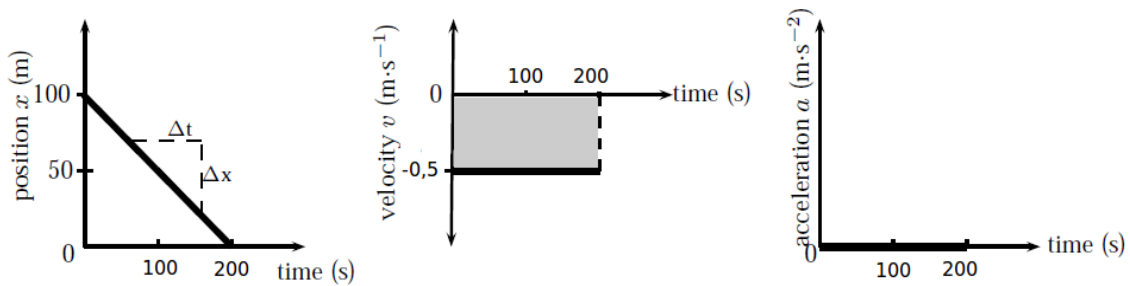

c) The slope or gradient of the position versus time graph in part a is positive, while in part b it is negative. This is because in part a Thandi is walking in the positive direction and in part b she is walking in the negative direction. The velocity in part b is negative, while the velocity in part a is positive. The acceleration in both cases is 0.

Exercise 21-6:

1. A car is parked 10 m from home for 10 minutes. Draw a displacement-time, velocity-time and acceleration-time graphs for the motion. Label all the axes.

Solution:

The car is stationary and so its velocity and acceleration are 0. We take home to be the reference point and then the car remains 10 m away from home for the entire 10 minute time period.

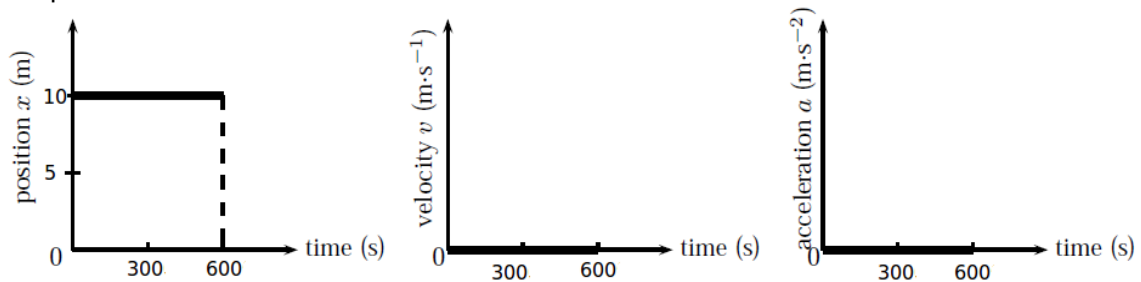

2. A bus travels at a constant velocity of $12\text{m}\cdot\text{s}^{-1}$ for 6 seconds. Draw the displacement-time, velocity-time and acceleration-time graph for the motion. Label all the axes.

Solution:

The displacement is $12\text{m}\cdot\text{s}^{-1} \times 6\text{s} = 72\text{m}$ The graphs are:

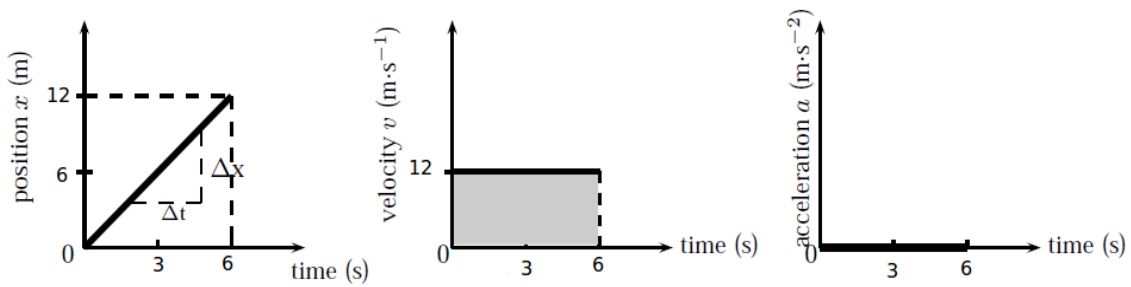

3. An athlete runs with a constant acceleration of $1\text{ m}\cdot\text{s}^{-2}$ for 4 s. Draw the acceleration-time, velocity-time and displacement-time graphs for the motion. Accurate values are only needed for the acceleration-time and velocity-time graphs.

Solution:

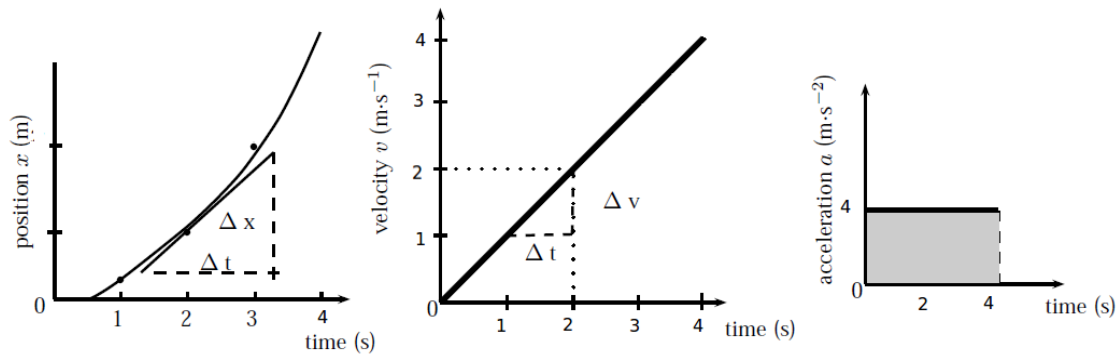

The velocity is the area under the acceleration-time graph. This area is a rectangle with length 4 and width 4. So the velocity is $4\text{ m}\cdot\text{s}^{-1}$.

4. The following velocity-time graph describes the motion of a car. Draw the displacement-time graph and the acceleration-time graph and explain the motion of the car according to the three graphs.

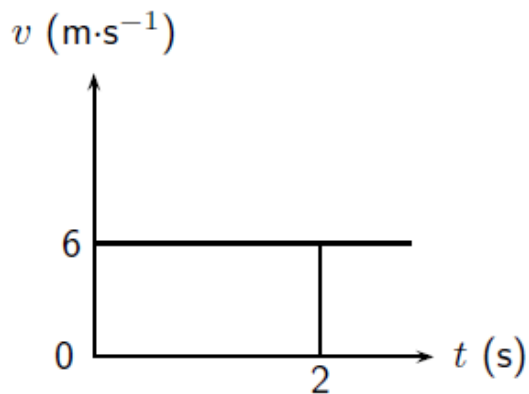

Solution:

The velocity is constant for the entire time of the motion.

The displacement is the area under the graph. Since the area is a rectangle the displacement is: $6 \times 2 = 12m$.

The displacement-time graph is:

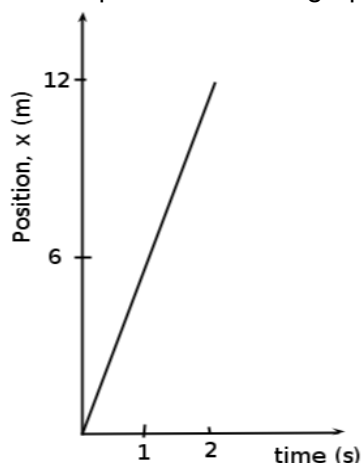

The gradient of the velocity-time graph gives us the acceleration. The gradient is 0 and so the acceleration is $0m \cdot s^{-2}$

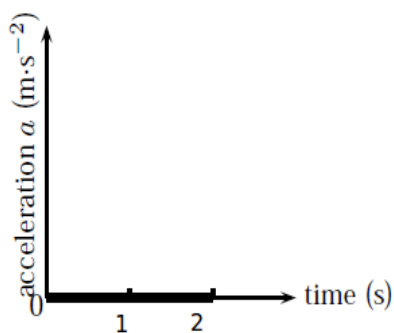

The velocity of the car is constant ($6m \cdot s^{-1}$) for the entire time of the motion. The final displacement is 12 m. The acceleration is $0m \cdot s^{-2}$ for the entire time.

5. The following velocity-time graph describes the motion of a truck. Draw the displacement-time graph and the acceleration-time graph and explain the motion of the truck according to the three graphs.

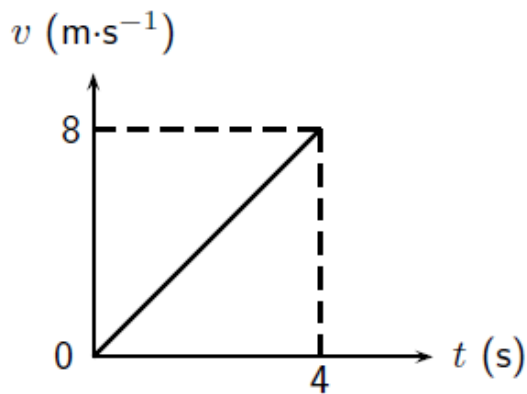

Solution:

The acceleration is the gradient of the velocity-time graph. The gradient is:

$$m = \frac{y_2 - y_1}{x_2 - x_1}$$

$$m = \frac{8 - 0}{4 - 0}$$

$$m = 2$$

The acceleration is $2 \text{ m} \cdot \text{s}^{-2}$

The displacement is the area under the velocity-time graph and is 16 m.

The graphs are:

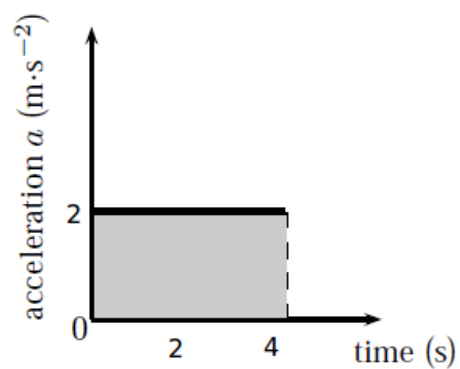
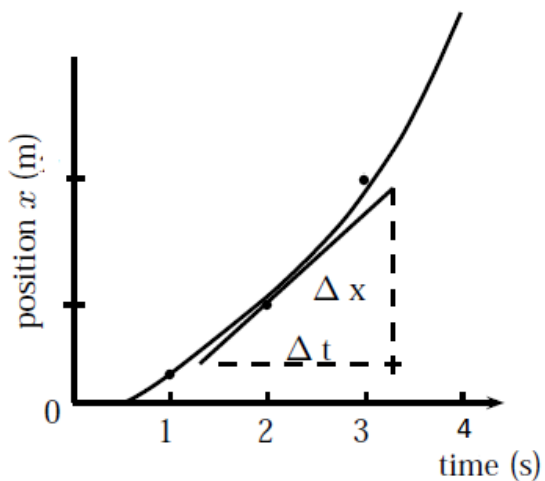

The truck has a constant acceleration of $2 \text{ m} \cdot \text{s}^{-2}$. Its velocity increases to a final velocity of

$8m \cdot s^{-1}$. The final displacement is 16 m.

Exercise 21-7:

1. A car starts off at $10m \cdot s^{-1}$ and accelerates at $1m \cdot s^{-2}$ for 10 s. What is its final velocity?

Solution:

We use the equations of motion. We are given the initial velocity, acceleration and the time taken. We are asked to find the final velocity.

$$v_f = v_i + at$$

$$v_f = 10 + (1)(10)$$

$$v_f = 20m \cdot s^{-1}$$

2. A train starts from rest, and accelerates at $1m \cdot s^{-2}$ for 10 s. How far does it move?

Solution:

We are given the initial velocity ($0m \cdot s^{-1}$, since it starts from rest). We also are given the time and the acceleration. We want the distance.

$$\Delta x = v_i \cdot t + \frac{1}{2}at^2$$

$$\Delta x = 0 + \frac{1}{2}1(10^2)$$

$$\Delta x = 50m$$

3. A bus is going $30m \cdot s^{-1}$ and stops in 5 s. What is its stopping distance for this speed?

Solution:

The final velocity is $0m \cdot s^{-1}$, since the bus stops. The initial velocity and time are given.

The acceleration is given by:

$$v_f = v_i + at$$

$$a = \left(\frac{v_f - v_i}{t} \right)$$

$$a = \left(\frac{0 - 30}{5} \right)$$

$$a = -6 \text{ m} \cdot \text{s}^{-2}$$

$$\Delta x = v_i t + \frac{1}{2} a t^2$$

$$\Delta x = (30)(5) + \left(\frac{1}{2} \right) (-6)(5)^2$$

$$\Delta x = 75 \text{ m}$$

4. A racing car going at $20 \text{ m} \cdot \text{s}^{-1}$ stops in a distance of 20 m. What is its acceleration?

Solution:

The final velocity is $0 \text{ m} \cdot \text{s}^{-1}$ since the car stops. The final velocity and distance are given.

$$v_f^2 = v_i^2 + 2a\Delta x$$

$$0 = (20)^2 + 2a(20)$$

$$0 = 400 + 40a$$

$$-40a = 400$$

$$a = -10 \text{ m} \cdot \text{s}^{-2}$$

The acceleration is negative which indicates that the racing car is slowing down.

5. A ball has a uniform acceleration of $4 \text{ m} \cdot \text{s}^{-2}$. Assume the ball starts from rest. Determine the velocity and displacement at the end of 10 s.

Solution:

We are given the acceleration and time. The initial velocity is $0 \text{ m} \cdot \text{s}^{-1}$.

The final velocity is:

$$v_f = v_i + at$$

$$v_f = 0 + (4)(10)$$

$$v_f = 40 \text{ m} \cdot \text{s}^{-1}$$

The displacement is:

$$\Delta x = \left(\frac{v_f + v_i}{2} \right) t$$

$$\Delta x = \left(\frac{0 + 40}{2} \right) (10)$$

$$\Delta x = 200m$$

6. A motorcycle has a uniform acceleration of $4 m \cdot s^{-2}$. Assume the motorcycle has an initial velocity of $20 m \cdot s^{-1}$. Determine the velocity and displacement at the end of 12 s.

Solution:

We are given the acceleration, the initial velocity and the time.

The final velocity is:

$$v_f = v_i + at$$

$$v_f = 20 + (4)(12)$$

$$v_f = 68 m \cdot s^{-1}$$

The displacement is:

$$\Delta x = v_i t + \frac{1}{2} at^2$$

$$\Delta x = (20)(12) + \left(\frac{1}{2} \right) (4)(12)^2$$

$$\Delta x = 528m$$

7. An aeroplane accelerates uniformly such that it goes from rest to $144 km \cdot hr^{-1}$ in 8 s. Calculate the acceleration required and the total distance that it has travelled in this time.

Solution:

We are given the time, the initial velocity ($0 m \cdot s^{-1}$, since it starts from rest) and the final velocity. We must convert the final velocity into $m \cdot s^{-1}$.

$$\frac{144 km}{1 hour} = \frac{144 \times 1000}{60 \times 60 \times 1} = 40 m \cdot s^{-1}$$

The acceleration is:

$$v_f = v_i + at$$
$$40 = 0 + 8a$$

$$a = 5 \text{ m} \cdot \text{s}^{-2}$$

The distance travelled in this time is:

$$\Delta x = v_i t + \frac{1}{2} a t^2$$

$$\Delta x = (0)(8) + \frac{1}{2}(5)(8)^2$$

$$\Delta x = 160 \text{ m}$$

End of chapter exercises:

1. Give one word/term for the following descriptions.
 - a) The shortest path from start to finish.
 - b) A physical quantity with magnitude and direction.
 - c) The quantity defined as a change in velocity over a time period.
 - d) The point from where you take measurements.
 - e) The distance covered in a time interval.
 - f) The velocity at a specific instant in time.

Solution:

- a) Displacement
- b) Vector
- c) Acceleration
- d) Reference point
- e) Velocity
- f) Instantaneous velocity

2. Choose an item from column B that match the description in column A. Write down only the letter next to the question number. You may use an item from column B more than

once.

Column A	Column B
a. The area under a velocity - time graph	gradient
b. The gradient of a velocity - time graph	area
c. The area under an acceleration - time graph	velocity
d. The gradient of a displacement - time graph	displacement
	acceleration
	slope

Solution:

- a) Displacement
- b) Acceleration
- c) velocity
- d) velocity

3. Indicate whether the following statements are TRUE or FALSE. Write only 'true' or 'false'. If the statement is false, write down the correct statement.

- a) An example of a scalar is the displacement of an object over a time interval.
- b) The position of an object is where it is located.
- c) The sign of the velocity of an object tells us in which direction it is travelling.
- d) The acceleration of an object is the change of its displacement over a period in time.

Solution:

- a) False. An example of a vector is the displacement of an object over a time interval. An example of a scalar is the distance of an object over a time interval.
- b) True
- c) True
- d) False. The acceleration of an object is the change of its velocity over a period of time.

4. A body accelerates uniformly from rest for t_0 seconds after which it continues with a constant velocity. Which graph is the correct representation of the body's motion?

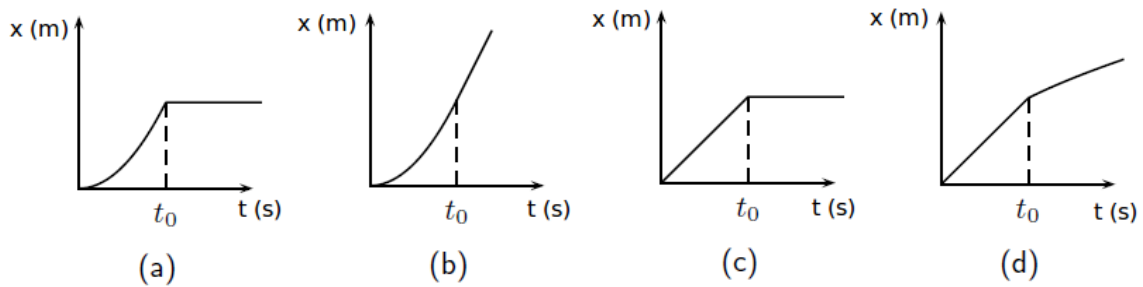

Solution:

Graph b. Graph d does not have uniform acceleration, graph a and c do not have constant velocity after time t_0 . Graph b has uniform acceleration and then constant velocity.

5. The velocity-time graphs of two cars are represented by P and Q as shown:

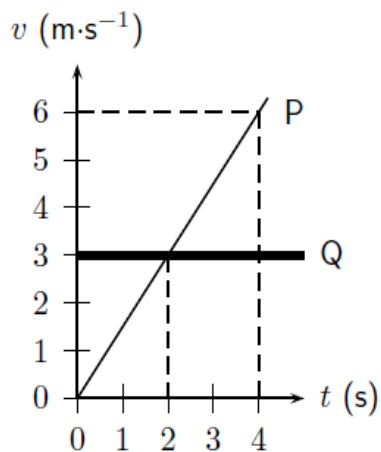

The difference in the distance travelled by the two cars (in m) after 4 s is . . .

- a) 12
- b) 6
- c) 2
- d) 0

Solution:

d) 0

6. The graph that follows shows how the speed of an athlete varies with time as he sprints for 100 m.

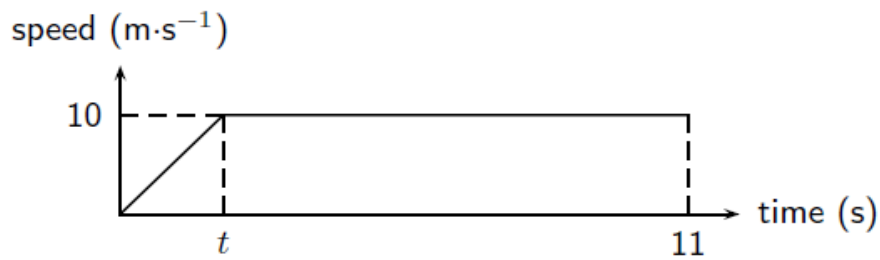

Which of the following equations can be used to correctly determine the time t for which he accelerates?

- a) $100 = (10)(11) - \frac{1}{2}10t$
- b) $100 = (10)(11) + \frac{1}{2}(10)t$
- c) $100 = 10t + \frac{1}{2}(10)t^2$
- d) $100 = \frac{1}{2}(0)t + \frac{1}{2}(10)t^2$

Solution:

a) $100 = (10)(11) - \frac{1}{2}10t$

7. In which one of the following cases will the distance covered and the magnitude of the displacement be the same?

- a) A girl climbs a spiral staircase.
- b) An athlete completes one lap in a race.
- c) A raindrop falls in still air.
- d) A passenger in a train travels from Cape Town to Johannesburg.

Solution:

In part b, the athlete ends where he started and so his displacement is 0, while his distance is some number. In part a, the displacement will be less than the distance. In part d, the track is not straight all the way and so the displacement and distance will be different.

Part c however will have the same distance and displacement. The raindrop falls vertically down, it ends in a different place from where it started, and moves in a straight line (straight down). This gives the distance that it falls and the displacement to be the same.

8. A car, travelling at constant velocity, passes a stationary motor cycle at a traffic light. As the car overtakes the motorcycle, the motorcycle accelerates uniformly from rest for 10 s. The following displacement-time graph represents the motions of both vehicles from the traffic light onwards.

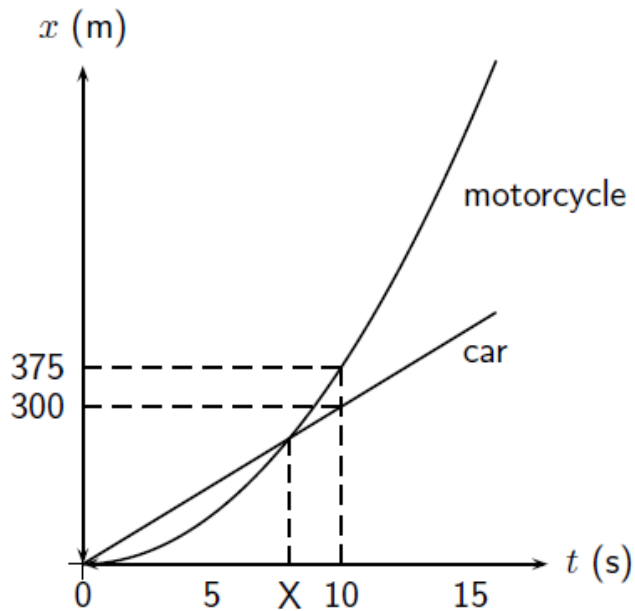

- Use the graph to find the magnitude of the constant velocity of the car.
- Use the information from the graph to show by means of calculation that the magnitude of the acceleration of the motorcycle, for the first 10 s of its motion is $7,5m \cdot s^{-2}$.
- Calculate how long (in seconds) it will take the motorcycle to catch up with the car (point X on the time axis).
- How far behind the motorcycle will the car be after 15 seconds?

Solution:

- a) The magnitude of the constant velocity of the car is the same as the gradient of the line:

$$m = \frac{y_2 - y_1}{x_2 - x_1}$$

$$m = \frac{300 - 0}{10 - 0}$$

$$m = 30$$

So the magnitude of the constant velocity is: $30m \cdot s^{-1}$

- b) We can use the equations of motion. The total distance covered in 10 s is 375 m and

the time taken is 10 s. The acceleration is:

$$\Delta x = v_i t + \frac{1}{2} a t^2$$

$$375 = 0(10) + \frac{1}{2} a (10^2)$$

$$375 = 50a$$

$$a = 7,5 m \cdot s^{-2}$$

c) We use the equations of motion to find the displacement of the motorcycle:

$$\Delta x = v_i t + \frac{1}{2} a t^2$$

$$= 0 + \frac{1}{2} (7,5 t^2)$$

$$= 3,75 t^2$$

And the car's displacement is:

$$\Delta x = v_i t + \frac{1}{2} a t^2$$

$$= 30t + 0$$

$$= 30t$$

At point X the displacement of the car will be equal to the displacement of the motorcycle:

$$3,75 t^2 = 30t$$

$$3,75 t^2 - 30t = 0$$

$$t(t-8) = 0$$

So $t = 0$ or $t = 8$. Since t is greater than 0, $t = 8$ s.

So the motorcycle will take 8 s to catch up with the car.

d) After 15 s the car has travelled a distance of:

$$\Delta x = v_i t + \frac{1}{2} a t^2$$

$$\Delta x = (30)(15) + 0$$

$$\Delta x = 450m$$

At 10 s the motorcycle will have travelled 375 m (read off graph)

So its velocity will be:

$$v_f = v_i + at$$

$$v_f = 0 + (7,5)(10)$$

$$v_f = 75m \cdot s^{-1}$$

And from 10 to 15 s the distance will be:

$$\Delta x = v_i t + \frac{1}{2}at^2$$

$$\Delta x = (75)(5) + 0$$

$$\Delta x = 375m$$

The total distance travelled is: $375 + 375 = 750m$

So the motorcycle will have travelled $750 - 450 = 300m$ further than the car. The car will be 300 m behind the motorcycle after 15 s.

9. Which of the following statements is true of a body that accelerates uniformly?

- a) Its rate of change of position with time remains constant.
- b) Its position changes by the same amount in equal time intervals.
- c) Its velocity increases by increasing amounts in equal time intervals.
- d) Its rate of change of velocity with time remains constant.

Solution:

- d) Its rate of change of velocity with time remains constant.

10. The velocity-time graph for a car moving along a straight horizontal road is shown below.

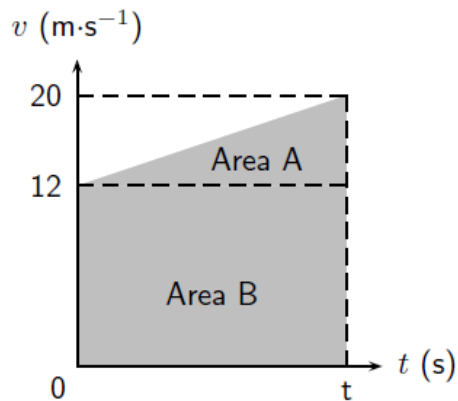

Which of the following expressions gives the magnitude of the average velocity of the car?

- a) $\frac{\text{Area A}}{t}$
- b) $\frac{\text{Area A} + \text{Area B}}{t}$
- c) $\frac{\text{Area B}}{t}$
- d) $\frac{\text{Area A} - \text{Area B}}{t}$

Solution:

- b) $\frac{\text{Area A} + \text{Area B}}{t}$

11. A car is driven at $25\text{m} \cdot \text{s}^{-1}$ in a municipal area. When the driver sees a traffic officer at a speed trap, he realises he is travelling too fast. He immediately applies the brakes of the car while still 100 m away from the speed trap.

- a) Calculate the magnitude of the minimum acceleration which the car must have to avoid exceeding the speed limit, if the municipal speed limit is $16.6\text{m} \cdot \text{s}^{-1}$.
- b) Calculate the time from the instant the driver applied the brakes until he reaches the speed trap. Assume that the car's velocity, when reaching the trap, is $16.6\text{m} \cdot \text{s}^{-1}$.

Solution:

a) To avoid exceeding the speed limit his final velocity must be $16,6 \text{ m} \cdot \text{s}^{-1}$ or less. The acceleration is:

$$\begin{aligned}v_f^2 &= v_i^2 + 2a\Delta x \\(16,6)^2 &= (25)^2 + 2(100)a \\275,56 &= 625 + 200a \\a &= -1,75 \text{ m} \cdot \text{s}^{-2}\end{aligned}$$

b)

$$\begin{aligned}v_f &= v_i + at \\16,6 &= 25 + (-1,75)t \\1,75t &= 8,4 \\t &= 4,8 \text{ s}\end{aligned}$$

12. A traffic officer is watching his speed trap equipment at the bottom of a valley. He can see cars as they enter the valley 1 km to his left until they leave the valley 1 km to his right. Nelson is recording the times of cars entering and leaving the valley for a school project. Nelson notices a white Toyota enter the valley at 11:01:30 and leave the valley at 11:02:42. Afterwards, Nelson hears that the traffic officer recorded the Toyota doing $140 \text{ km} \cdot \text{hr}^{-1}$.

- What was the time interval (Δt) for the Toyota to travel through the valley?
- What was the average speed of the Toyota?
- Convert this speed to $\text{km} \cdot \text{hr}^{-1}$.
- Discuss whether the Toyota could have been travelling at $140 \text{ km} \cdot \text{hr}^{-1}$ at the bottom of the valley.
- Discuss the differences between the instantaneous speed (as measured by the speed trap) and average speed (as measured by Nelson).

Solution:

a) 72 s

b) The Toyota covered a distance of 2 km in 72 s. This is 2 000 m in 72 s. The average speed is:

$$\begin{aligned}\text{speed} &= \text{distance}/\text{time} \\s &= 2000/72 \\s &= 27,78 \text{ m} \cdot \text{s}^{-1}\end{aligned}$$

c) $27,78 \times 36001 \times 1000 = 100\text{km} \cdot \text{h}^{-1}$

d) The Toyota could have been travelling at $140\text{km} \cdot \text{hr}^{-1}$ at the bottom of the valley. The Toyota may have been accelerating towards the speed trap and then started slowing down. The average speed that Nelson measured does not take changes in acceleration into account.

e) Instantaneous speed is the speed at a specific moment in time. Average speed is the total distance covered divided by the time taken. Average speed assumes that you are travelling at the same speed for the entire distance while instantaneous speed looks at your speed for a specific moment in time.

13. A velocity-time graph for a ball rolling along a track is shown below. The graph has been divided up into 3 sections, A, B and C for easy reference. (Disregard any effects of friction.)

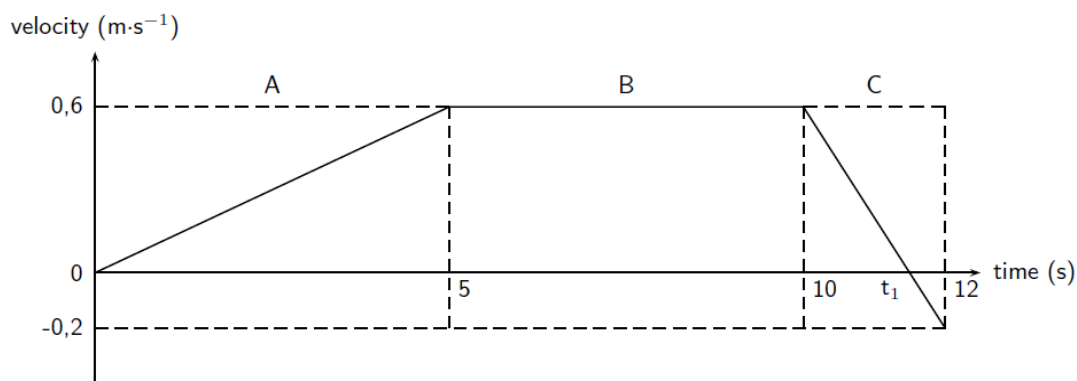

a) Use the graph to determine the following:

- (i) the speed 5 s after the start
- (ii) the distance travelled in Section A
- (iii) the acceleration in Section C

b) At time t_1 the velocity-time graph intersects the time axis. Use an appropriate equation of motion to calculate the value of time t_1 (in s).

c) Sketch a displacement-time graph for the motion of the ball for these 12 s. (You do not need to calculate the actual values of the displacement for each time interval, but do pay attention to the general shape of this graph during each time interval.)

Solution:

a)

- (i) 5 s after the start the ball's speed is $0,6\text{m} \cdot \text{s}^{-1}$

ii) The distance travelled is the area under the graph. The distance is:

$$\text{area} = \frac{1}{2}(5)(0,6) = 1,5m$$

iii) The acceleration is the slope of the graph.

$$m = \frac{y_2 - y_1}{x_2 - x_1}$$

$$m = \frac{-0,2 - 0,6}{12 - 10}$$

$$m = \frac{-0,8}{2}$$

$$m = -0,4$$

The acceleration is: $-0,4m \cdot s^{-2}$

b) At time t_1 the final velocity is 0. The initial velocity is 0,6. The acceleration is -0,4.

$$v_f = v_i + at$$

$$0 = 0,6 - 0,4t$$

$$t = 1,5s$$

So t_1 is: $t_1 = 1,5 + 10 = 11,5s$

c)

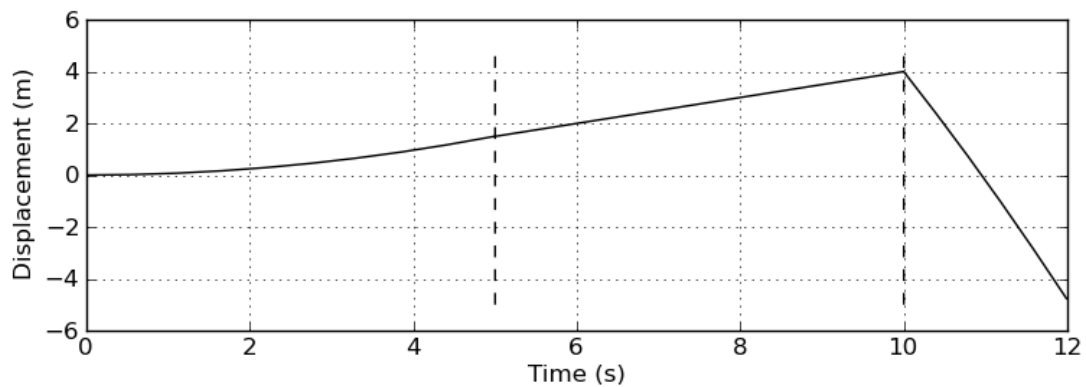

14. In towns and cities, the speed limit is $60\text{km}\cdot\text{hr}^{-1}$. The length of the average car is 3.5 m, and the width of the average car is 2 m. In order to cross the road, you need to be able to walk further than the width of a car, before that car reaches you. To cross safely, you should be able to walk at least 2 m further than the width of the car (4 m in total), before the car reaches you.

- If your walking speed is $4\text{km}\cdot\text{hr}^{-1}$, what is your walking speed in $\text{m}\cdot\text{s}^{-1}$?
- How long does it take you to walk a distance equal to the width of the average car?
- What is the speed in $\text{m}\cdot\text{s}^{-1}$ of a car travelling at the speed limit in a town?
- How many metres does a car travelling at the speed limit travel, in the same time that it takes you to walk a distance equal to the width of car?
- Why is the answer to the previous question important?
- If you see a car driving toward you, and it is 28 m away (the same as the length of 8 cars), is it safe to walk across the road?
- How far away must a car be, before you think it might be safe to cross? How many car-lengths is this distance?

Solution:

a) Your walking speed is: $\frac{4\text{km}}{1\text{hour}} = \frac{4 \times 1000}{1 \times 60 \times 60} = \frac{4000}{3600} = 1,11\text{m}\cdot\text{s}^{-1}$

b) $\text{speed} = \frac{\text{distance}}{\text{time}}$

$$1,11 = \frac{2}{t}$$

$$t = 1,8\text{s}$$

c) The speed of a car travelling at the speed limit is: $\frac{60\text{km}}{1\text{hour}} = \frac{60 \times 1000}{1 \times 60 \times 60} = 16,67\text{m}\cdot\text{s}^{-1}$

d) $\text{speed} = \frac{\text{distance}}{\text{time}}$

$$16,67 = \frac{x}{1,8}$$

$$x = 30\text{m}$$

e) It helps determine the safe distance of a car.

f) No. In the time it takes you to cross the car will have travelled 30 m and have hit you.

g) 60 m to be certain you will make it. This is 18 car lengths. You walk 2 m in 1,8 s. So in order to cover 4 m safely the car must be 60 m away.

15. A bus on a straight road starts from rest at a bus stop and accelerates at $2\text{m}\cdot\text{s}^{-2}$ until it reaches a speed of $20\text{m}\cdot\text{s}^{-1}$. Then the bus travels for 20 s at a constant speed until the driver sees the next bus stop in the distance. The driver applies the brakes, stopping the bus in a uniform manner in 5 s.

- How long does the bus take to travel from the first bus stop to the second bus stop?
- What is the average velocity of the bus during the trip?

Solution:

We draw a rough sketch of the problem and define a positive direction:

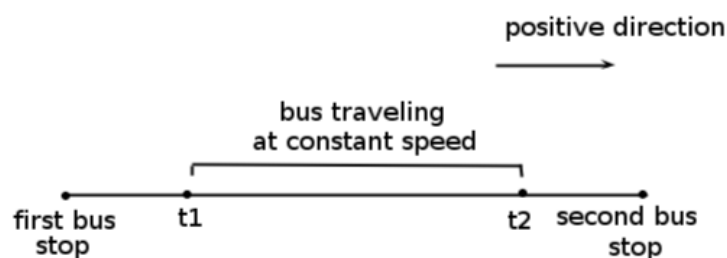

- We first find the time taken for the bus to reach a speed of $20\text{m}\cdot\text{s}^{-1}$:

$$v_f = v_i + at$$

$$20 = 0 + 2t$$

$$t = 10\text{s}$$

Now we have the time for each part of the journey and so we can add all the times together to get the total time: $10 + 20 + 5 = 35\text{s}$

The bus takes 35 s to get from one bus stop to the next.

- Average velocity is the displacement divided by the total time. So we need to find the displacement of the bus.

For the first part of the journey the displacement is:

$$\Delta x = v_i(t) + \frac{1}{2}at^2$$

$$\Delta x = 0(10) + \frac{1}{2}(2)(10^2)$$

$$\Delta x = +100m$$

For the second part of the journey the displacement is:

The bus is travelling at a constant speed of $20m \cdot s^{-1}$ for 20 s. The displacement is:
 $(20m \cdot s^{-1})(20) = +400m$

For the third part of the journey the bus starts with a speed of $20m \cdot s^{-1}$ and ends with a speed of $0m \cdot s^{-1}$. The displacement is:

$$\Delta x = \frac{v_i + v_f}{2}(t)$$

$$\Delta x = \frac{20+0}{2}(5)$$

$$\Delta x = +50m$$

The total displacement is: $100 + 400 + 50 = +550m$

So the average velocity is: $\frac{550}{35} = 15,71m \cdot s^{-1}$

Chapter 22. Mechanical energy

Exercise 22-1:

1. Describe the relationship between an object's gravitational potential energy and its:

- a) mass
- b) height above a reference point

Solution:

- a) The potential energy is proportional to the mass of the object, i.e. $PE \propto m$
- b) The potential energy is proportional to the height above a reference point, i.e. $PE \propto h$

2. A boy, of mass 30 kg, climbs onto the roof of their garage. The roof is 2,5m from the ground.

- a) How much potential energy has the boy gained by climbing on the roof?
- b) The boy now jumps down. What is the potential energy of the boy when he is 1m from the ground?
- c) What is the potential energy of the boy when he lands on the ground?

Solution:

a) mass = 30kg, height = 2,5 m

$$PE = m g h$$

$$PE = (30)(9,8)(2,5)$$

$$PE = 735J$$

b) h = 1m, mass = 30kg

$$PE = mgh = (30)(9,8)(1) = 294J$$

c) When he is on the ground the height is 0 and so the potential energy is 0J.

3. A hiker, of mass 70 kg, walks up a mountain, 800 m above sea level, to spend the night

at the top in the first overnight hut. The second day she walks to the second overnight hut, 500 m above sea level. The third day she returns to her starting point, 200m above sea level.

- a) What is the potential energy of the hiker at the first hut (relative to sea level)?
- b) How much potential energy has the hiker lost during the second day?
- c) How much potential energy did the hiker have when she started her journey (relative to sea level)?
- d) How much potential energy did the hiker have at the end of her journey, when she reached her original starting position?

Solution:

a) $m = 70\text{kg}$, $h = 800\text{m}$

$$PE = m g h = (70)(9,8)(800) = 548800\text{J} = 548,8\text{kJ}$$

b) $PE = m g (h_1 - h_2)$

$$PE = (70)(9,8)(800 - 500)$$

$$PE = (70)(9,8)(300)$$

$$PE = 205800\text{J} = 205,8\text{kJ}$$

c) $PE_{\text{start}} = m g h = (70)(9,8)(200) = 137200\text{J} = 137,2\text{kJ}$

d) $PE_{\text{end}} = (70)(9,8)(200) = 137200\text{J} = 137,2\text{kJ}$

Exercise 22-2:

1. Describe the relationship between an object's kinetic energy and its:

- a) mass and
- b) velocity

Solution:

a) The kinetic energy is directly proportional to the mass. As the mass increases, so does the kinetic energy.

b) The kinetic energy is directly proportional to the square of the velocity, i.e. $KE \propto v^2$.

2. A stone with a mass of 100 g is thrown up into the air. It has an initial velocity of $3\text{m}\cdot\text{s}^{-1}$.

Calculate its kinetic energy:

- a) as it leaves the thrower's hand
- b) when it reaches its turning point

Solution:

We draw a sketch of the problem:

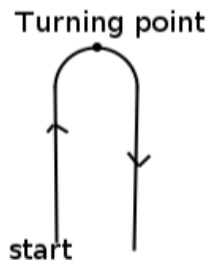

- a) We convert the mass to kilograms: $\frac{100}{1000}=0,1\text{kg}$.

We are given the initial velocity and since the question asks us to find the kinetic energy at the start (i.e. when it leaves the thrower's hand) we use the initial velocity.

$$\text{KE}=\frac{1}{2}mv^2$$

$$\text{KE}=\frac{1}{2}(0,1)(3)^2$$

$$\text{KE}=0,45\text{J}$$

- b) At the turning point the velocity of the stone is 0. So the kinetic energy is:

$$\text{KE}=\frac{1}{2}(0,1)(0)^2=0\text{J}$$

3. A car with a mass of 700 kg is travelling at a constant velocity of $100\text{km}\cdot\text{hr}^{-1}$. Calculate the kinetic energy of the car.

Solution:

We first convert the velocity to the correct units: $\frac{100\times 1000}{3600}=27,78\text{m}\cdot\text{s}^{-1}$.

(To get m we multiply by 1 000 and to get s we divide by 60×60).

Now we can work out the kinetic energy:

$$KE = \frac{1}{2}mv^2$$

$$KE = \frac{1}{2}(700)(27,78)$$

$$KE = 270104,94J$$

Exercise 22-3:

1. A tennis ball, of mass 120 g, is dropped from a height of 5 m. Ignore air friction.

a) What is the potential energy of the ball when it has fallen 3 m?

b) What is the velocity of the ball when it hits the ground?

Solution:

a) $m = 0,12 \text{ kg}$, $h = 3 \text{ m}$

$$PE = m g h$$

$$PE = (0,12)(9,8)(3)$$

$$PE = 3,528J$$

b) $PE_{\text{top}} = (5)(9,8)(0,12) = 5,88J$

From the principle of conservation of mechanical energy we get: $PE_{\text{top}} = KE_{\text{bottom}}$

So $KE_{\text{bottom}} = 5,88J$

And the velocity is:

$$KE = \frac{1}{2}mv^2$$

$$5,88 = \frac{1}{2}(0,12)(v^2)$$

$$0,06v^2 = 5,88$$

$$v = 9,90m \cdot s^{-1}$$

2. A ball rolls down a hill which has a vertical height of 15 m. Ignoring friction, what would be the

a) gravitational potential energy of the ball when it is at the top of the hill?

b) velocity of the ball when it reaches the bottom of the hill?

Solution:

We use the conservation of mechanical energy:

$$E_{P \text{ top}} + E_{K \text{ top}} = E_{P \text{ bottom}} + E_{K \text{ bottom}}$$

$$E_{P \text{ top}} = E_{K \text{ bottom}}$$

$$mgh = \frac{1}{2}mv^2$$

$$gh = \frac{1}{2}v^2$$

a) So the potential energy at the top is: $E_{P \text{ top}} = gh = (9,8)(15) = 147 \text{ J}$

b) And the velocity at the bottom is:

$$E_{K \text{ bottom}} = \frac{1}{2}v^2$$

$$147 = \frac{1}{2}v^2$$

$$v^2 = 294$$

$$v = 17,15 \text{ m}\cdot\text{s}^{-1}$$

3. A bullet, mass 50 g, is shot vertically up in the air with a muzzle velocity of $200\text{m}\cdot\text{s}^{-1}$. Use the Principle of Conservation of Mechanical Energy to determine the height that the bullet will reach. Ignore air friction.

Solution:

The muzzle velocity is the initial velocity.

We draw a rough sketch to help understand the problem.

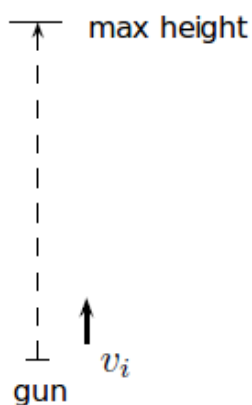

Note that the kinetic energy at the start is the same as the kinetic energy at the bottom, and the potential energy at the end is the same as the potential energy at the top.

$$KE_{\text{start}} = \frac{1}{2}mv^2 = \frac{1}{2}(0,05\text{kg})(200\text{m}\cdot\text{s}^{-1})^2 = 1000\text{J}$$

From the law of conservation of mechanical energy this is equal to the potential energy at the end.

$$PE = 1000 = (0,05)(9,8)(h)$$

$$h = 2040,92\text{m}$$

4. A skier, mass 50 kg, is at the top of a 6,4 m ski slope.

a) Determine the maximum velocity that she can reach when she skis to the bottom of the slope.

b) Do you think that she will reach this velocity? Why/Why not?

Solution:

a) The potential energy at the start is: $PE_{\text{start}} = mgh = (50)(9,8)(6,4) = 3136\text{J}$

From the principle of conservation of mechanical energy this is equal to the kinetic energy at the bottom.

$$KE_{\text{end}} = \frac{1}{2}mv^2$$

$$3136 = \frac{1}{2}(50)(v^2)$$

$$v^2 = 125,44$$

$$v = 11,2\text{m}\cdot\text{s}^{-1}$$

b) She will not reach this velocity. In the calculations we ignored friction, but in real life friction would have to be taken into account. Due to the friction she will slow down as she skies downward and so will only reach a velocity of less than this.

5. A pendulum bob of mass 1,5 kg, swings from a height A to the bottom of its arc at B. The velocity of the bob at B is $4\text{m}\cdot\text{s}^{-1}$. Calculate the height A from which the bob was released. Ignore the effects of air friction.

Solution:

We first draw a rough sketch of the situation.

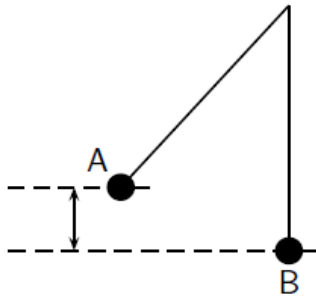

We apply the law of conservation of mechanical energy.

$$PE_A = KE_B$$

$$m g h_A = \frac{1}{2} m v_B^2$$

$$(9,8)(h_A) = \frac{1}{2}(4m \cdot s^{-1})$$

$$h_A = \frac{2}{9,8}$$

$$h_A = 0,20m$$

6. Prove that the velocity of an object, in free fall, in a closed system, is independent of its mass.

$$U_{\text{start}} = U_{\text{end}}$$

$$PE_{\text{start}} + KE_{\text{start}} = PE_{\text{end}} + KE_{\text{end}}$$

$$m g h_{\text{start}} + \frac{1}{2} m (v_{\text{start}})^2 = m g h_B + \frac{1}{2} m (v_B)^2$$

$$m g h_{\text{start}} + 0 = 0 + \frac{1}{2} m (v_{\text{end}})^2$$

$$m g h_{\text{start}} = \frac{1}{2} m (v_{\text{end}})^2$$

As the mass, m , of the object appears on both sides of the equation, it can be eliminated so that the equation becomes:

$$g h_{\text{start}} = \frac{1}{2} (v_{\text{end}})^2$$

$$2g h_{\text{start}} = (v_{\text{end}})^2$$

This expression does not have m in it and so the velocity of an object in free fall, in a closed system, is independent of the mass of the object.

End of chapter exercises:

1. Give one word/term for the following descriptions.

- a) The force with which the Earth attracts a body.
- b) The unit for energy.
- c) The movement of a body in the Earth's gravitational field when no other forces act on it.
- d) The sum of the potential and kinetic energy of a body.
- e) The amount of matter an object is made up of.

Solution:

- a) Gravitational force
- b) Joules
- c) Free fall
- d) Mechanical energy
- e) Mass

2. Consider the situation where an apple falls from a tree. Indicate whether the following statements regarding this situation are TRUE or FALSE. Write only 'true' or 'false'. If the statement is false, write down the correct statement.

- a) The potential energy of the apple is a maximum when the apple lands on the ground.
- b) The kinetic energy remains constant throughout the motion.
- c) To calculate the potential energy of the apple we need the mass of the apple and the height of the tree.
- d) The mechanical energy is a maximum only at the beginning of the motion.
- e) The apple falls at an acceleration of $9,8m \cdot s^{-2}$.

Solution:

- a) False. The kinetic energy of the apple is a maximum when the apple lands on the ground.
- b) False. The mechanical energy remains constant throughout its motion.
- c) True. However, we must also choose a reference point.
- d) False. The kinetic energy is a maximum only at the beginning of the motion.
- e) True.

3. A man fires a rock out of a slingshot directly upward. The rock has an initial velocity of $15\text{m}\cdot\text{s}^{-1}$.

a) What is the maximum height that the rock will reach?

b) Draw graphs to show how the potential energy, kinetic energy and mechanical energy of the rock changes as it moves to its highest point.

Solution:

$$\text{a) } KE_{\text{bottom}} = \frac{1}{2}mv^2 = PE_{\text{top}}$$

$$\frac{1}{2}mv^2 = mgh$$

$$h = \frac{v^2}{2g}$$

$$h = \frac{15^2}{2(9,8)}$$

$$h = 11,48\text{m}$$

b) Potential energy:

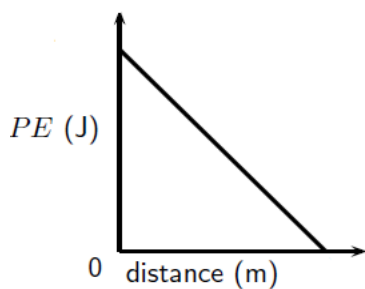

Kinetic energy:

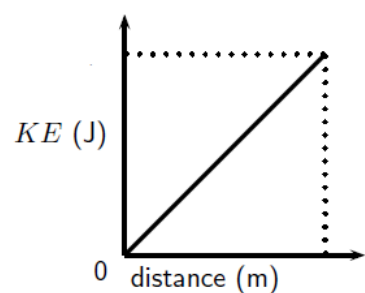

Mechanical energy:

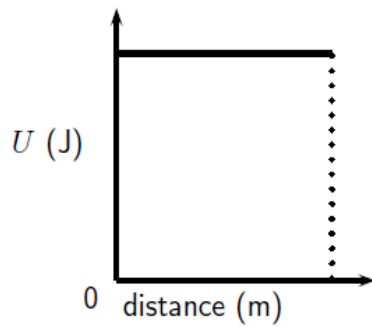

4. A metal ball of mass 200 g is tied to a light string to make a pendulum. The ball is pulled to the side to a height (A), 10 cm above the lowest point of the swing (B). Air friction and the mass of the string can be ignored. The ball is let go to swing freely.

- Calculate the potential energy of the ball at point A.
- Calculate the kinetic energy of the ball at point B.
- What is the maximum velocity that the ball will reach during its motion?

Solution:

We first convert all units:

$$\text{mass: } \frac{200}{1000} = 0,2 \text{ kg}$$

$$\text{Height: } \frac{10}{100} = 0,1 \text{ m}$$

We also draw a rough sketch:

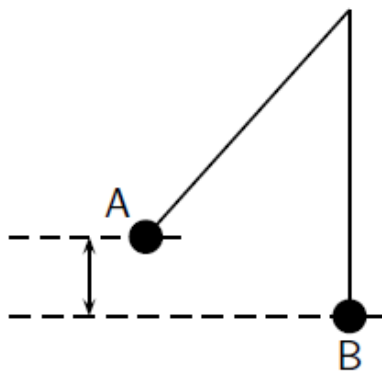

$$\text{a) } PE = mgh = (0,2)(9,8)(0,1) = 0,196 \text{ J}$$

b) By conservation of mechanical energy:

$$PE_A = KE_B$$

$$KE_B = 0,196J$$

$$c) \frac{1}{2}mv^2 = 0,196$$

$$\frac{1}{2}(0,2)v^2 = 0,196$$

$$(0,1)v^2 = 0,196$$

$$v = 1,4m \cdot s^{-1}$$

5. A truck of mass 1,2 tons is parked at the top of a hill, 150 m high. The truck driver lets the truck run freely down the hill to the bottom.

- What is the maximum velocity that the truck can achieve at the bottom of the hill?
- Will the truck achieve this velocity? Why/why not?

Solution:

a) 1 ton = 1 000 kg so mass = 1 200 kg.

$$PE = mgh = (1200)(9,8)(150) = 1764000J$$

From the conservation of mechanical energy:

$$KE = \frac{1}{2}mv^2 = 1764000$$

$$\frac{1}{2}(1200)v^2 = 1764000$$

$$v = 54,22m \cdot s^{-1}$$

b) No. The above calculations do not take friction into account and this will slow the truck down.

6. A stone is dropped from a window, 6 metres above the ground. The mass of the stone is 25 grams. Use the Principle of Conservation of Energy to determine the speed with which the stone strikes the ground.

Solution:

We must first convert the mass to kg:

$$m = \frac{25}{1000} = 0,025 \text{ kg}$$

From the conservation of mechanical energy:

$$PE_{\text{top}} = KE_{\text{bottom}}$$

$$mgh = \frac{1}{2}mv^2$$

$$v^2 = 2gh$$

$$v = \sqrt{(2)(9,8)(3)}$$

$$v = 7,7 \text{ m} \cdot \text{s}^{-1}$$

Chapter 23. The hydrosphere

End of chapter exercises

1. What is the hydrosphere? How does it interact with other global systems?

Solution:

The hydrosphere is all the water bodies on Earth. The hydrosphere includes rivers, lakes, streams, oceans and groundwater. The hydrosphere interacts with the atmosphere, the lithosphere and the biosphere. In the atmosphere water from lakes, rivers, streams etc. evaporates into the atmosphere. This evaporated water later returns to the earth in the form of rain or snow. In the lithosphere water helps break down rocks into smaller fragments (this is weathering). Water then transports these fragments to other places (erosion). These two processes, weathering and erosion, shape the face of the earth. In the biosphere, plants absorb water through their roots and then this water returns to the hydrosphere through transpiration (evaporation of water from plant leaves).

2. Why is the hydrosphere important?

Solution:

Water is part of living cells and so all living organisms need water

Water provides a habitat for many animals and plants

Water helps to regulate climate

Humans need water to drink and for their biological processes

3. Write a one page essay on the importance of water and what can be done to ensure that we still have drinkable water in 50 years time.

Solution:

Answer should include the following points:

Why water is needed for life, e.g. is part of cells, provides a habitat, regulates climate, drinking water, etc.

Conservation of water e.g. taking a shower instead of a bath, using a low flow shower head, using minimal flush toilets, using washing machines with a full load, etc.

Dealing with pollution, e.g. not throwing rubbish into rivers, educating companies to not throw waste into rivers, etc.

Decreasing the amount of water that humans use.