



MATHEMATICS

Grade 9 - Term 2

CAPS

Learner Book

Revised edition

sasol
inzalo
foundation



UKUQONDA
i n s t i t u t e

**Developed and funded as an ongoing project by the Sasol Inzalo
Foundation in partnership with the Ukuqonda Institute.**

Published by The Ukuqonda Institute
9 Neale Street, Rietondale 0084
Registered as a Title 21 company, registration number 2006/026363/08
Public Benefit Organisation, PBO Nr. 930035134
Website: <http://www.ukuqonda.org.za>

This edition published in 2017
© 2017. Copyright in the work is vested in the publisher.
Copyright in the text remains vested in the contributors.

ISBN: 978-1-4315-2881-3

This book was developed with the participation of the Department of Basic Education of South Africa with funding from the Sasol Inzalo Foundation.

Contributors:

Herholdt Bezuidenhout, Lucinda Cruickshank, Marthinus de Jager, Gudrun Elliott, Andrew Hofmeyr, Piet Human, Louise Keegan, Erna Lampen, Nathi Makae, Enoch Masemola, Alwyn Olivier, Cerenus Pfeiffer, Rika Potgieter, Johan Pretorius, Renate Röhrs, Paul van Koersveld, Therine van Niekerk, Dirk Wessels

Subject advisors from the DBE who contributed by means of review: The publisher thanks those subject advisors of the DBE who reviewed this book series on four occasions in 2013-2014, as well as in October 2017. The authors changed the text so as to align with the reviewers' requests/suggestions for improvements, as far as possible, and believe that the books improved as a result of that.

Illustrations and computer graphics:

Leonora van Staden, Lisa Steyn Illustration
Zhandré Stark, Lebone Publishing Services

Computer graphics for chapter frontispieces: Piet Human

Cover illustration: Leonora van Staden

Text design: Mike Schramm

Layout and typesetting: Lebone Publishing Services

Printed by: [printer name and address]

COPYRIGHT NOTICE

Your freedom to legally copy this book

This book is published under a Creative Commons Attribution-NonCommercial 4.0 International Licence (CC BY-NC).

You are allowed and encouraged to freely copy this book. You can photocopy, print and distribute it as often as you like. You may download it onto any electronic device, distribute it via email, and upload it to your website, at no charge. You may also adapt the text and illustrations, provided you acknowledge the copyright holders (“attribute the original work”).

Restrictions: You may not make copies of this book for a profit-seeking purpose. This holds for printed, electronic and web-based copies of this book, and any part of this book.

For more information about the Creative Commons Attribution-NonCommercial 4.0 International (CC BY-NC 4.0) licence, see: <https://creativecommons.org/licenses/by-nc/4.0/>



Except where otherwise noted, this work is licensed under the Creative Commons Attribution-NonCommercial 4.0 International licence.

Contents

Term 1

Chapter 1: Whole numbers.....	1
Chapter 2: Integers.....	19
Chapter 3: Fractions.....	27
Chapter 4: The decimal notation for fractions.....	39
Chapter 5: Exponents.....	46
Chapter 6: Patterns.....	53
Chapter 7: Functions and relationships.....	62
Chapter 8: Algebraic expressions.....	67
Chapter 9: Equations.....	85

Term 2

Chapter 10: Construction of geometric figures.....	93
Chapter 11: Geometry of 2D shapes.....	110
Chapter 12: Geometry of straight lines.....	127
Chapter 13: Pythagoras' Theorem.....	136
Chapter 14: Area and perimeter of 2D shapes.....	145

Term 3

Chapter 15: Functions.....	157
Chapter 16: Algebraic expressions.....	165
Chapter 17: Equations.....	176
Chapter 18: Graphs	187
Chapter 19: Surface area, volume and capacity of 3D objects	210
Chapter 20: Transformation geometry.....	219
Chapter 21: Geometry of 3D objects	235

Term 4

Chapter 22: Collect, organise and summarise data.....	249
Chapter 23: Representing data.....	257
Chapter 24: Interpret, analyse and report on data.....	269
Chapter 25: Probability.....	280

CHAPTER 10

Construction of geometric figures

10.1 Constructing perpendicular lines

REVISING PERPENDICULAR LINES

In Grade 8, you learnt about **perpendicular lines**.

1. What does it mean if we say that two lines are perpendicular?
2. Use your protractor to measure the angles between the following pairs of lines. Then state whether they are perpendicular or not.

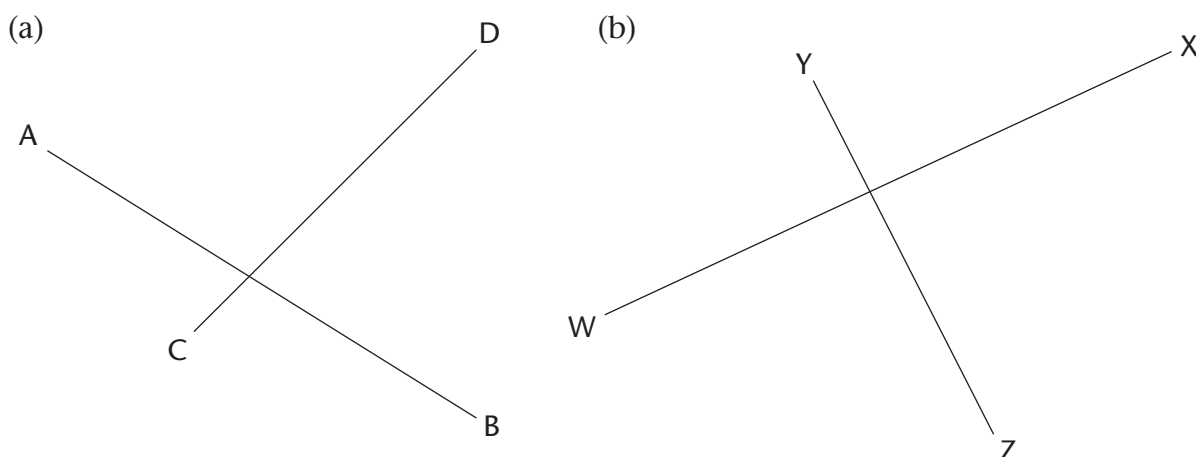

LINES THAT FORM WHEN CIRCLES INTERSECT

1. Do the following:
 - (a) Use a compass to draw two overlapping circles of different sizes.
 - (b) Draw a line through the points where the circles intersect (overlap).
 - (c) Draw a line to join the centres of the circles.

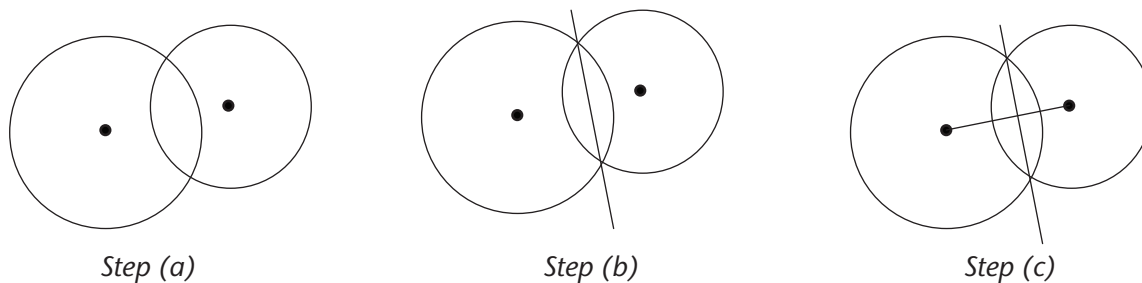

- (d) Use your protractor to measure the angles between the intersecting lines.
 (e) What can you say about the intersecting lines?

2. Repeat questions 1(a) to (e) with circles that are the same size.
 3. What conclusion can you make about a line drawn between the intersection points of two overlapping circles and a line through their centres?

USING CIRCLES TO CONSTRUCT PERPENDICULAR LINES

Case 1: A perpendicular through a point that is not on the line segment

Copy the steps below:

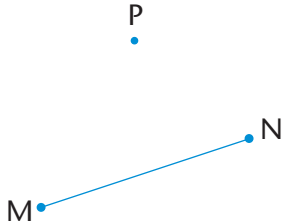
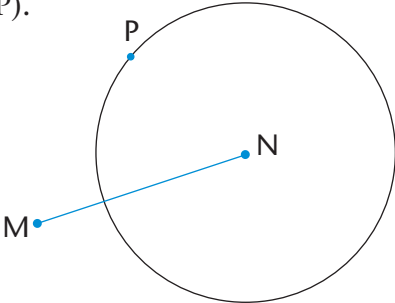
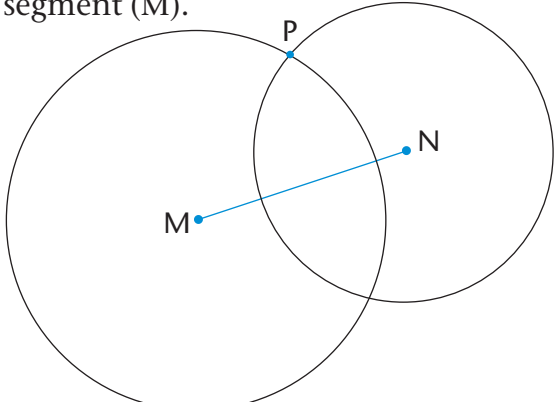
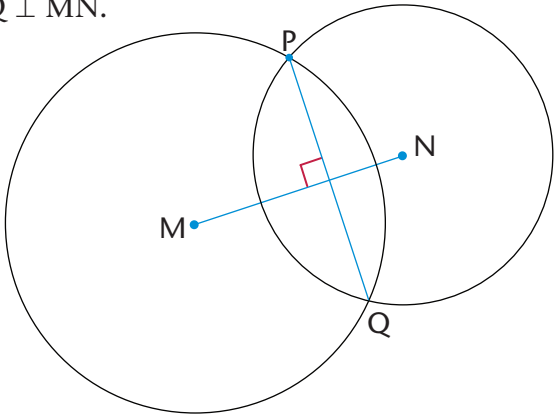
<p>You are given line segment MN with point P at a distance from it. You must construct a line that is perpendicular to MN, so that the perpendicular passes through point P.</p> 	<p>Step 1 Use your compass to draw a circle whose centre is the one end point of the line segment (N) and passes through the point (P).</p> 
<p>Step 2 Repeat step 1, but make the centre of your circle the other end point of the line segment (M).</p> 	<p>Step 3 Join the points where the circles intersect: $PQ \perp MN$.</p> 

Case 2: A perpendicular at a point that is on the line segment

Copy the steps below:

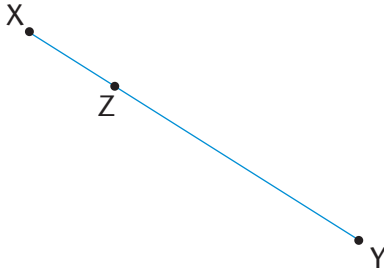
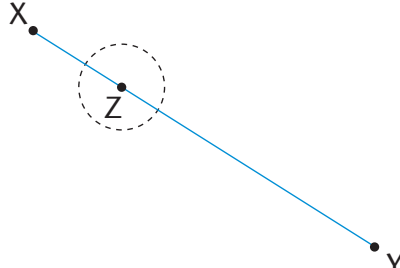
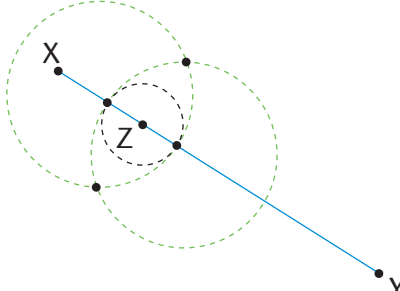
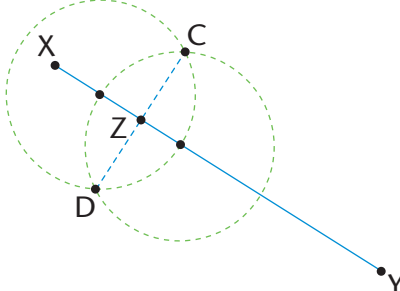
<p>You are given line segment XY with point Z on it. You must construct a perpendicular line passing through Z.</p> 	<p>Step 1 Use your compass to draw a circle whose centre is Z. Make its radius smaller than ZX. Note the two points where the circle intersects XY.</p> 
<p>Step 2 Set your compass wider than it was for the circle with centre Z. Draw two circles of the same size whose centres are at the two points where the first (black) circle intersects XY. The two (green) circles will overlap.</p> 	<p>Step 3 Join the intersection points of the two overlapping circles. Mark these points C and D: $CD \perp XY$ and passes through point Z.</p> 

PRACTISE USING CIRCLES TO CONSTRUCT PERPENDICULAR LINES

In each of the following two cases, copy the line segment, and draw a line that is perpendicular to the segment and passes through point P .

1.

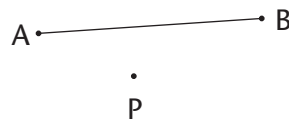

2.

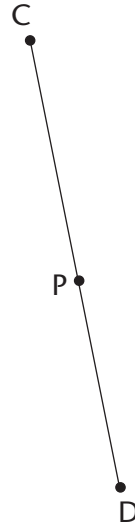

10.2 Bisecting angles

USING CIRCLES TO BISECT ANGLES

Work through the following example of using intersecting circles to **bisect** an angle. Do the following steps yourself.

To bisect something means "to cut in half".

You are given $\hat{A}BC$. You must bisect the angle.

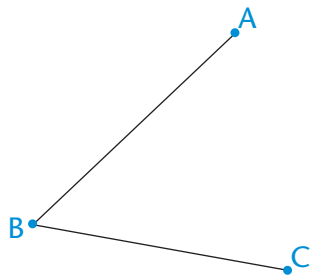

Step 1

Draw a circle with centre B to mark off an equal length on both arms of the angle. Label the points of intersection D and E: $DB = BE$.

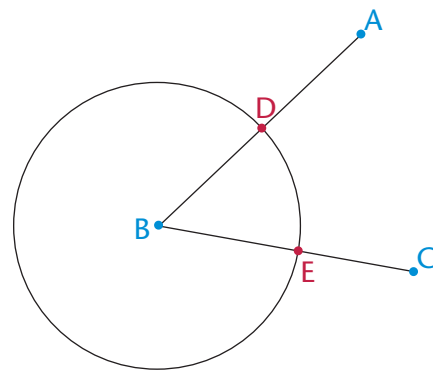

Step 2

Draw two equal circles with centres at D and at E. Make sure the circles overlap.

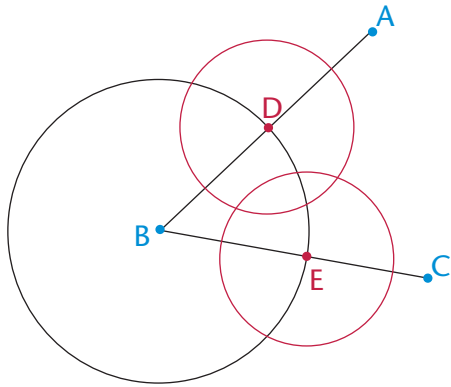
**Step 3**

Draw a line from B through the points where the two equal circles intersect. This line will bisect the angle.

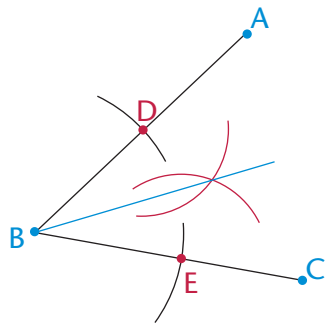
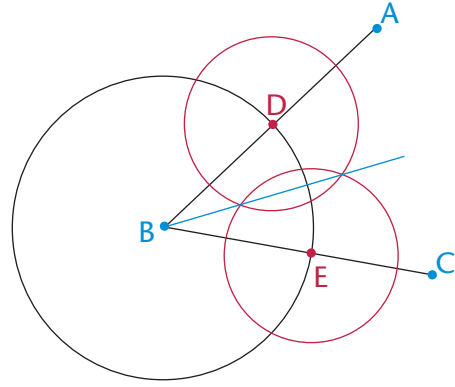

Same construction as in step 3 above

Can you explain why the method above works to bisect an angle?

Can you also see that we need not draw full circles, but can merely use parts of circles (arcs) to do the above construction?

PRACTISE BISECTING ANGLES

Copy the following angles and then bisect them without using a protractor:

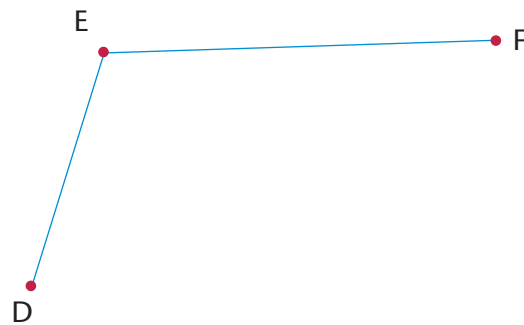
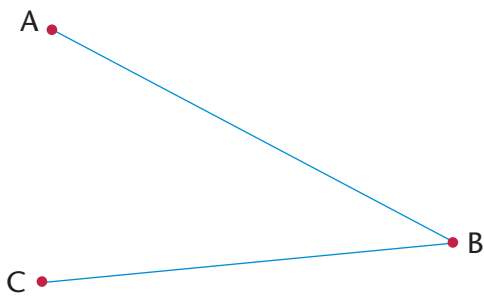

10.3 Constructing special angles without a protractor

Angles of 30° , 45° , 60° and 90° are known as **special angles**. You must be able to construct these angles without using a protractor.

CONSTRUCTING A 45° ANGLE

You have learnt how to draw a 90° angle and how to bisect an angle, without using a protractor. Copy the line below and use your knowledge on angles and bisecting angles to draw a 45° angle at point X on the line.

Hint: Extend the line to the left of X.



CONSTRUCTING 60° AND 30° ANGLES

1. What do you know about the sides and angles in an equilateral triangle?
2. Draw two circles with the following properties:
 - The circles are the same size.
 - Each circle passes through the other circle's centre.
 - The centres of the circles are labelled A and B.
 - The points of intersection of the circles are labelled D and E.

An example is shown on the right.

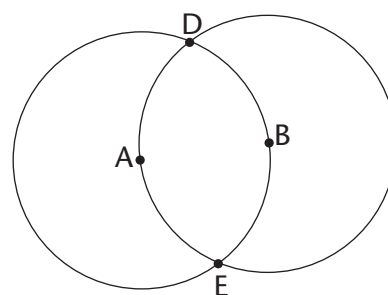

3. Draw in the following line segments: AB, AD and DB.
4. What can you say about the lengths of AB, AD and DB?

5. What kind of triangle is ABD?
6. Therefore, what do you know about \hat{A} , \hat{B} and \hat{D} ?
7. Use your knowledge of bisecting angles to create an angle of 30° on the construction you made in question 2.
8. Copy the line segment below and use what you have learnt to construct an angle of 60° at point P on the line segment.

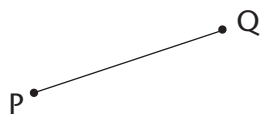

CONSTRUCTING THE MULTIPLES OF SPECIAL ANGLES

1. Copy and complete the table below. The first one has been done for you.

Angle	Multiples below 360°	Angle	Multiples below 360°
30°	$30^\circ; 60^\circ; 90^\circ; 120^\circ; 150^\circ; 180^\circ; 210^\circ; 240^\circ; 270^\circ; 300^\circ; 330^\circ$	45°	
60°		90°	

2. Construct the following angles without using a protractor. You will need to do more than one construction to create each angle.
 - (a) 120°
 - (b) 135°
 - (c) 270°
 - (d) 240°
 - (e) 150°

10.4 Angle bisectors in triangles

You learnt how to bisect an angle in Section 10.2.
Now you will investigate the angle bisectors in a triangle.
An **angle bisector** is a line that cuts an angle in half.

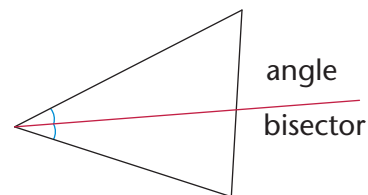

- Copy the acute triangle below. Bisect each of the angles of the acute triangle.
 - Extend each of the bisectors to the opposite side of the triangle.
 - What do you notice?
- Copy the obtuse angle below. Do the same with the obtuse triangle.
 - What do you notice?

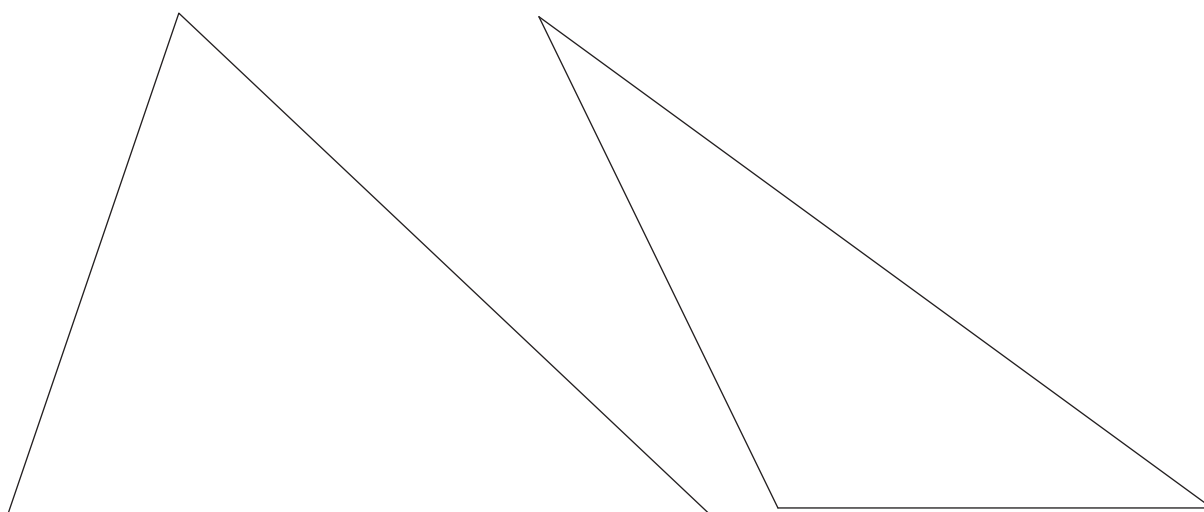

- Compare your triangles with those of two classmates. You should have the same results.

You should have found that the three **angle bisectors** of a triangle **intersect at one point**.

This point is the same distance away from each side of the triangle.

10.5 Interior and exterior angles in triangles

WHAT ARE INTERIOR AND EXTERIOR ANGLES?

An **interior angle** is an angle that lies between two sides of a triangle. It is inside the triangle. A triangle has three interior angles.

An **exterior angle** is an angle between a side of a triangle and another side that is extended. It is outside the triangle.

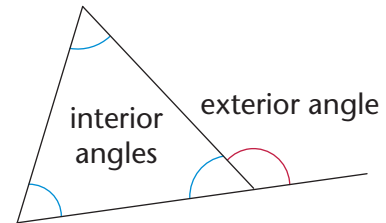

Look at $\triangle PQR$. Its three sides are extended to create three exterior angles.

Each exterior angle has one interior adjacent angle (next to it) and two **interior opposite angles**, as described in the following table:

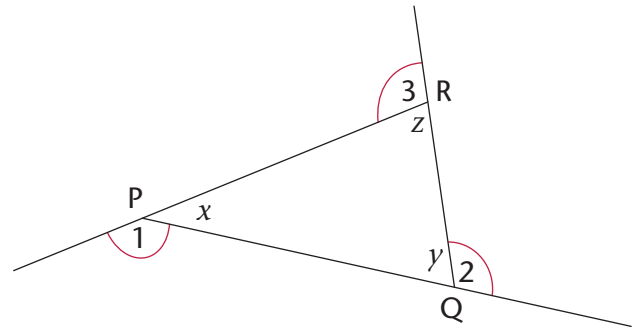

Exterior angle	Interior adjacent angle	Interior opposite angles
1	x	z and y
2	y	x and z
3	z	x and y

IDENTIFYING EXTERIOR ANGLES AND INTERIOR OPPOSITE ANGLES

- Copy the following table and name each exterior angle and its two interior opposite angles below.

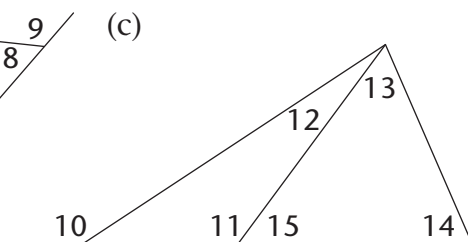
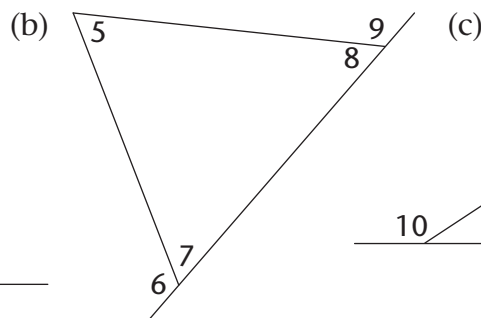
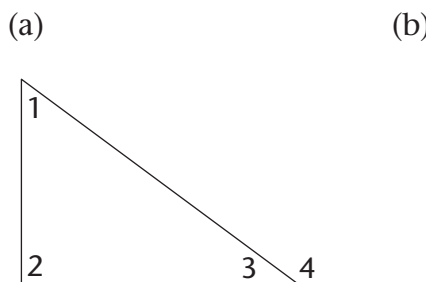

Ext. \angle					
Int. opp. \angle s					

2. $\triangle ABC$ below has each side extended in both directions to create six exterior angles.

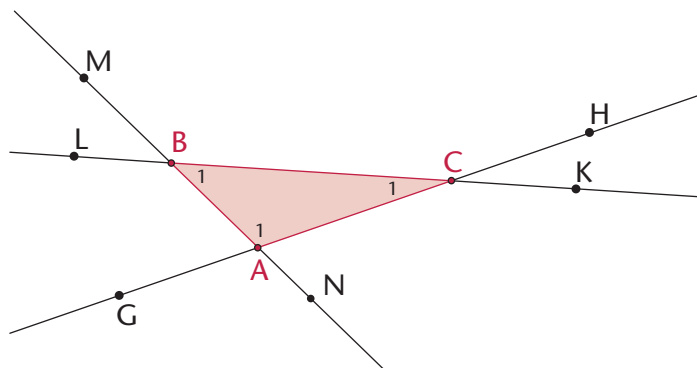

- Write down the names of the interior angles of the triangle.
- Since a triangle has three sides that can be extended in both directions, there are two exterior angles at each vertex. Write down the names of all the exterior angles of the triangle.
- Explain why $\widehat{M\hat{B}L}$ is not an exterior angle of $\triangle ABC$.
- Write down two other angles that are neither interior nor exterior.

INVESTIGATING THE EXTERIOR AND INTERIOR ANGLES IN A TRIANGLE

- Consider $\triangle LMN$. Write down the name of the exterior angle.
- Use a protractor to measure the interior angles and the exterior angle. Copy the drawing and write the measurements on the drawing.
- Use your findings in question 2 to complete the following sum:

$$\widehat{LMN} + \widehat{M\hat{L}N} = \dots$$

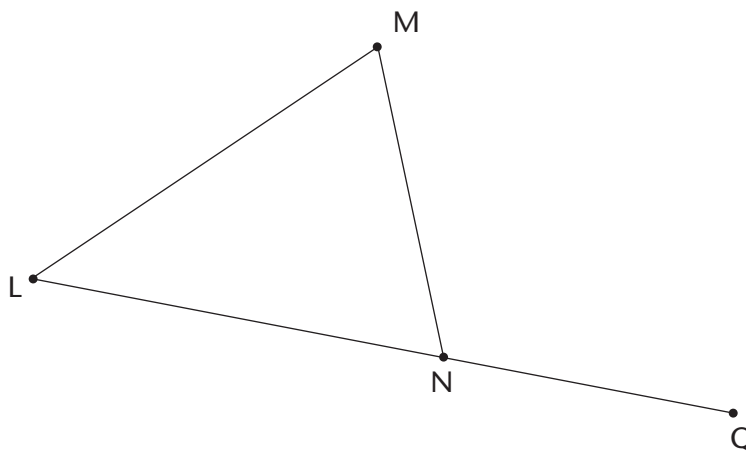

- What is the relationship between the exterior angle of a triangle and the sum of the interior opposite angles?

The **exterior angle** of a triangle is equal to the sum of the interior opposite angles.

5. Work out the sizes of angles a to f below, without using a protractor. Give reasons for the statements you make as you work out the answers.

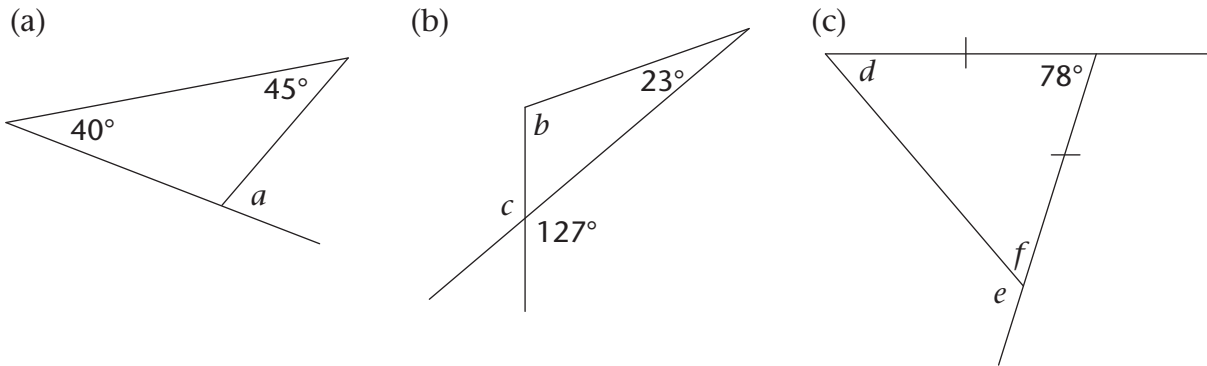

10.6 Constructing congruent triangles

Two triangles are **congruent** if they have exactly the **same shape** and **size**, i.e. they are able to fit exactly on top of each other. This means that all three corresponding sides and three corresponding angles are equal, as shown in the following two pairs:

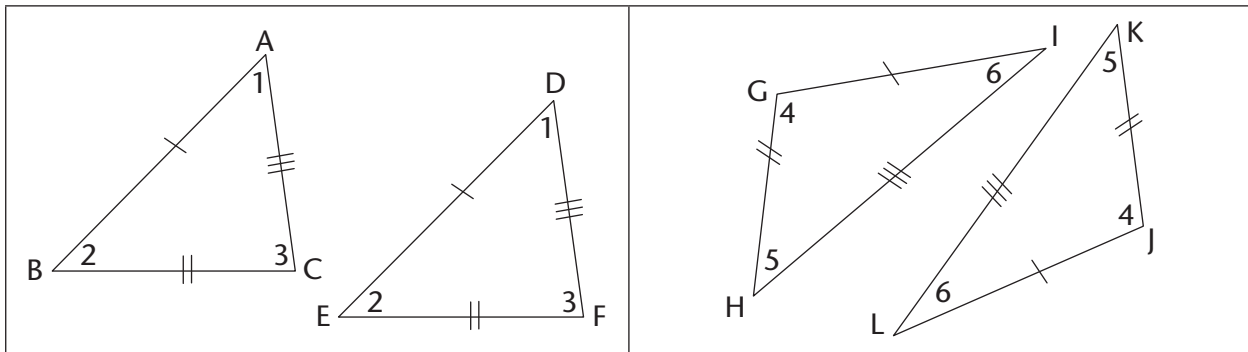

$\Delta ABC \cong \Delta DEF$ and $\Delta GHI \cong \Delta JKL$. In each pair, the corresponding sides and angles are equal.

MINIMUM CONDITIONS FOR CONGRUENCY

To determine if two triangles are congruent, we need a certain number of measurements, but not all of these. Let's investigate which measurements give us only one possible triangle.

- Use a ruler, compass and protractor to construct the following triangles. Each time minimum measurements are given.
 - Given three sides: side, side, side (SSS):
 ΔDEF with $DE = 7$ cm, $DF = 6$ cm and $EF = 5$ cm.
 - Given three angles: angle, angle, angle (AAA):
 ΔABC with $\hat{A} = 80^\circ$, $\hat{B} = 60^\circ$ and $\hat{C} = 40^\circ$.

- (c) Given one side and two angles: side, angle, angle (SAA):
 $\triangle GHI$ with $GH = 8$ cm, $\widehat{G} = 60^\circ$ and $\widehat{H} = 30^\circ$.
- (d) Given two sides and an included angle: side, angle, side (SAS):
 $\triangle JKL$ with $JK = 9$ cm, $\widehat{K} = 130^\circ$ and $KL = 7$ cm.
- (e) Given two sides and an angle that is not included: side, side, angle (SSA):
 $\triangle MNP$ with $MN = 10$ cm, $\widehat{M} = 50^\circ$ and $PN = 8$ cm.
- (f) Given a right angle, the hypotenuse and a side (RHS):
 $\triangle TRS$ with $TR \perp RS$, $RS = 7$ cm and $TS = 8$ cm.
- (g) Triangle UVW with $UV = 6$ cm and $VW = 4$ cm.
2. Compare your triangles with those of three classmates. Which of your triangles are congruent to theirs? Which are not congruent?
3. Go back to $\triangle MNP$ (question 1e). Did you find that you can draw two different triangles that both meet the given measurements? One of the triangles will be obtuse and the other acute. Follow the construction steps below to see why this is so.

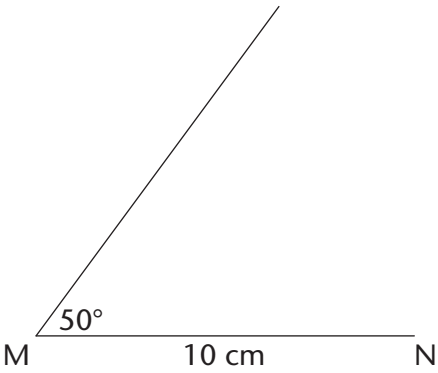
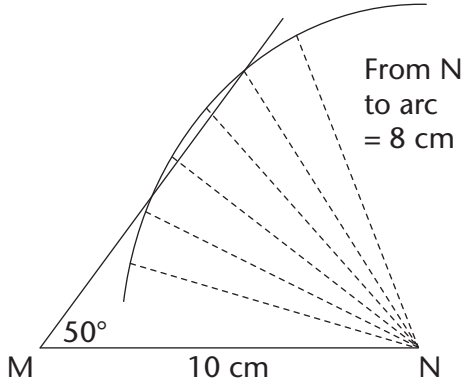
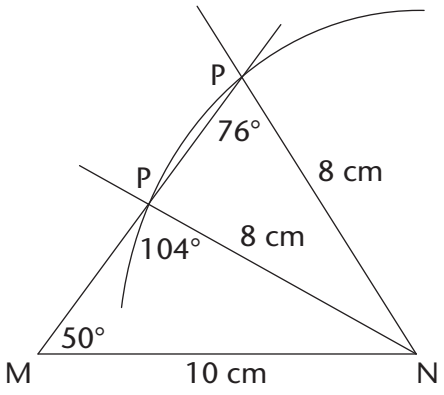
<p>Step 1</p> <p>Construct $MN = 10$ cm and the 50° angle at M, even though you do not know the length of the unknown side (MP).</p> 	<p>Step 2</p> <p>\widehat{N} is unknown, but $NP = 8$ cm. Construct an arc 8 cm from N. Every point on the arc is 8 cm from N.</p> 
<p>Step 3</p> <p>Point P must be 8 cm from N and fall on the unknown side of the triangle. The arc intersects the third side at two points, so P can be at either point.</p> <p>So two triangles are possible, each meeting the conditions given, i.e. $MN = 10$ cm, $NP = 8$ cm and $\widehat{M} = 50^\circ$.</p> 	

4. Copy and complete the table. Write down whether or not we can construct a congruent triangle when the following conditions are given.

Conditions	Congruent?
Three sides (SSS)	
Two sides (SS)	
Three angles (AAA)	
Two angles and a side (AAS)	
Two sides and an angle not between the sides (SSA)	
Two sides and an angle between the sides (SAS)	
Right-angled with the hypotenuse and a side (RHS)	

10.7 Diagonals of quadrilaterals

DRAWING DIAGONALS

A **diagonal** is a straight line inside a figure that joins two vertices of the figure, where the vertices are not next to each other.

- Look at the quadrilaterals below. The two diagonals of the square have been drawn in: AC and BD.
- Copy the quadrilaterals below and draw in the diagonals.

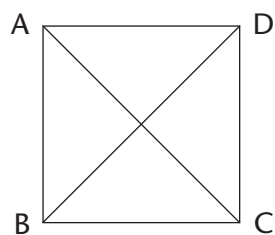

Square



Rectangle

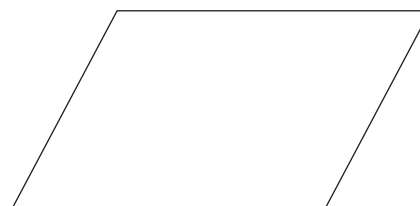

Parallelogram

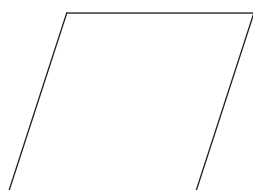

Rhombus

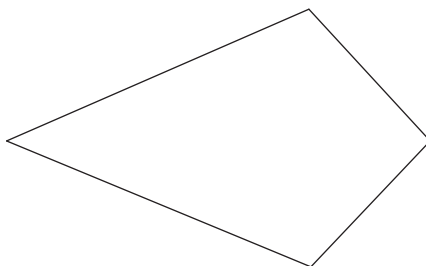

Kite

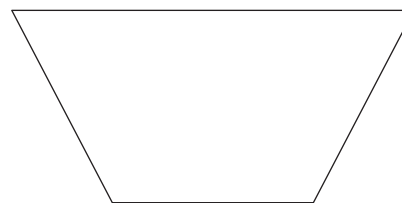

Trapezium

- How many sides does a quadrilateral have?
- How many angles does a quadrilateral have?
- How many diagonals does a quadrilateral have?

DIAGONALS OF A RHOMBUS

Below are two overlapping circles with centres A and B. The circles are the same size.

1. Construct a rhombus inside the circles by joining the centre of each circle with the intersection points of the circles. Join AB.
2. Copy the circles and construct the perpendicular bisector of AB. (Go back to Section 10.1 if you need help.) What do you find?

A **perpendicular bisector** is a line that cuts another line in half at a right angle (90°).

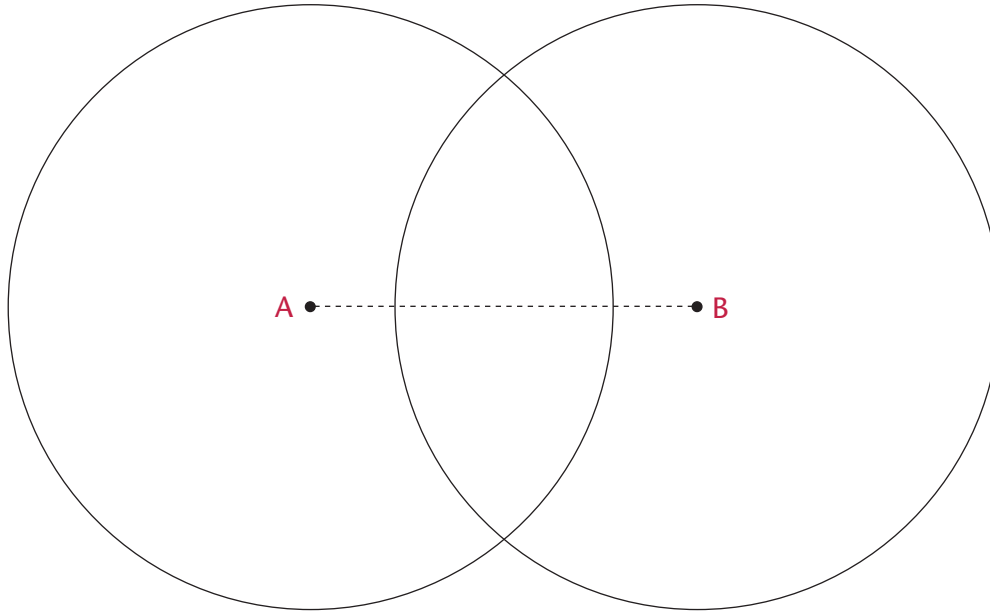

3. Do the diagonals bisect each other?
4. Copy and complete the sentence: The diagonals of a rhombus will always ...

DIAGONALS OF A KITE

Below are two overlapping circles with centres D and E. The circles are different sizes.

1. Copy the circles and construct a kite by joining the centre points of the circles to the intersection points of the circles.
2. Draw in the diagonals of the kite.
3. Mark all lines that are of the same length.

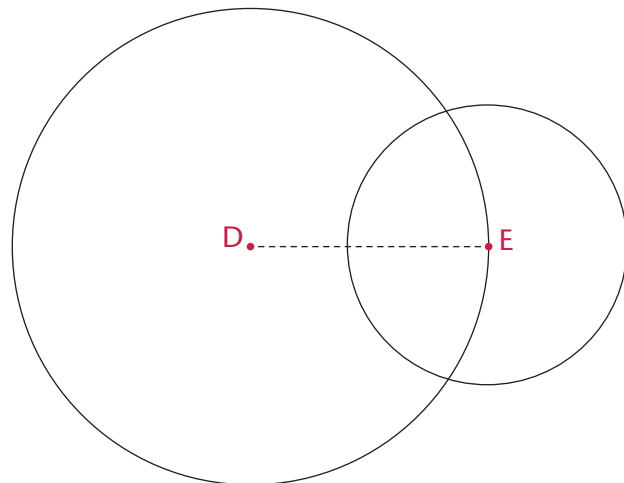

4. Are the diagonals of the kite perpendicular?
5. Do the diagonals of the kite bisect each other?
6. What is the difference between the diagonals of a rhombus and those of a kite?

DIAGONALS OF PARALLELOGRAMS, RECTANGLES AND SQUARES

1. Draw a parallelogram, rectangle and square onto grid paper.
2. Draw in the diagonals of the quadrilaterals.
3. Indicate on each shape all the lengths in the diagonals that are equal. (Use a ruler.)
4. Use the information you have found to copy and complete the table below. Fill in “yes” or “no”.

Quadrilateral	Diagonals equal	Diagonals bisect	Diagonals meet at 90°
Parallelogram			
Rectangle			
Square			

10.8 Angles in polygons

USING DIAGONALS TO INVESTIGATE THE SUM OF THE ANGLES IN POLYGONS

1. We can divide a quadrilateral into two triangles by drawing in one diagonal.
 - (a) Copy the polygons below and draw in diagonals to divide each of the polygons into as few triangles as possible.
 - (b) Write down the number of triangles in each polygon.

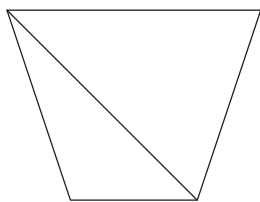

Quadrilateral

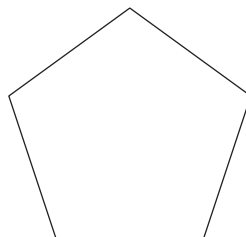

Pentagon

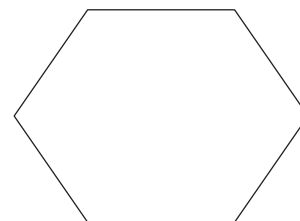

Hexagon

No. of Δ s	2		
Sum of \angle s	$2 \times 180^\circ = 360^\circ$		

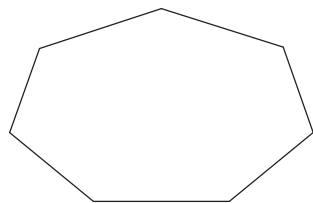

Heptagon

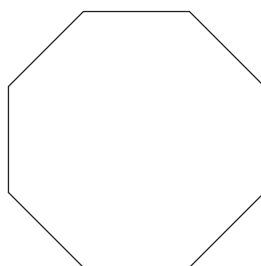

Octagon

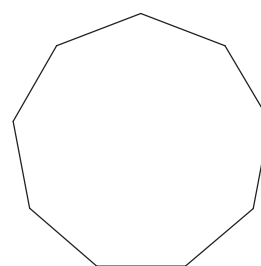

Nonagon

No. of Δs			
Sum of \angles			

2. The sum of the angles of one triangle = 180° . A quadrilateral is made up of two triangles, so the sum of the angles in a quadrilateral = $2 \times 180^\circ = 360^\circ$. Work out the sum of the interior angles of each of the other polygons above.

WORKSHEET

1. Match the words in the column on the right with the definitions on the left. Write the letter of the definition next to the matching word.

(a) A quadrilateral that has diagonals that are perpendicular and bisect each other	Kite
(b) A quadrilateral that has diagonals that are perpendicular to each other, and only one diagonal bisects the other	Congruent
(c) A quadrilateral that has equal diagonals that bisect each other	Exterior angle
(d) Figures that have exactly the same size and shape	Rhombus
(e) Divides into two equal parts	Perpendicular
(f) An angle that is formed outside a closed shape: it is between the side of the shape and a side that has been extended	Bisect
(g) Lines that intersect at 90°	Special angles
(h) 90° , 45° , 30° and 60°	Rectangle

2. Copy and complete the sentence: The exterior angle in a triangle is equal to ...
3. (a) Construct $\triangle PQR$ with angles of 30° and 60° . The side between the angles must be 8 cm. You may use only a ruler and a compass.
- (b) Will all triangles with the same measurements above be congruent to $\triangle PQR$? Explain your answer.

CHAPTER 11

Geometry of 2D shapes

11.1 Revision: Classification of triangles

1. Use a protractor to measure the interior angles of each of the following triangles. Write down the sizes of the angles.

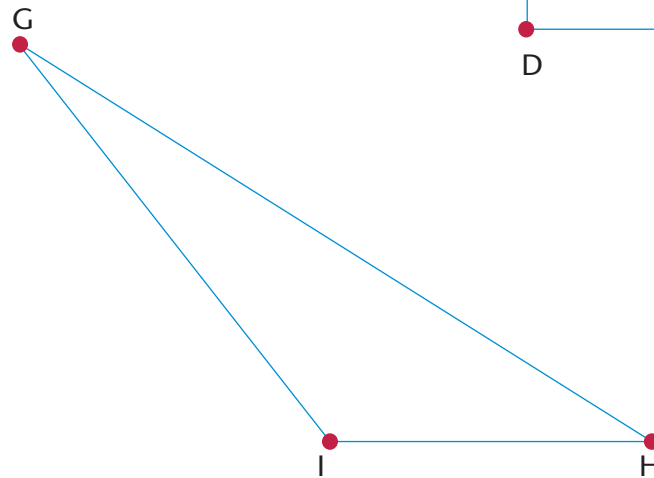
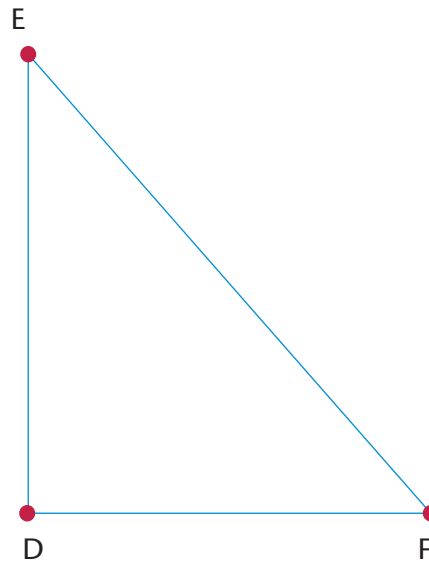
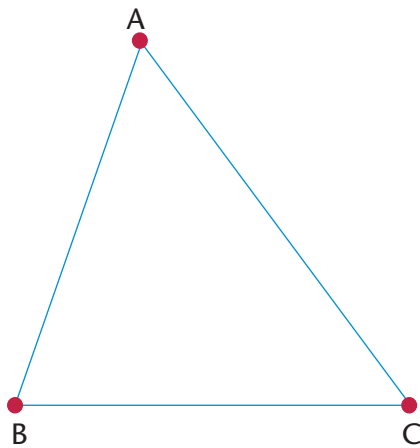

2. Classify the triangles in question 1 according to their angle properties. Copy and complete the following statements by choosing from the following types of triangles: **acute-angled**, **obtuse-angled** and **right-angled**.

(a) $\triangle ABC$ is an triangle, because

(b) $\triangle EDF$ is a triangle, because

(c) $\triangle GHI$ is an obtuse-angled triangle, because

3. The marked angles in each triangle below are equal. Copy and complete the following statements and classify the triangles according to angle and side properties.

(a) \triangle is an acute isosceles triangle, because and

(b) \triangle is a right-angled isosceles triangle, because and

(c) \triangle is an obtuse isosceles triangle, because and

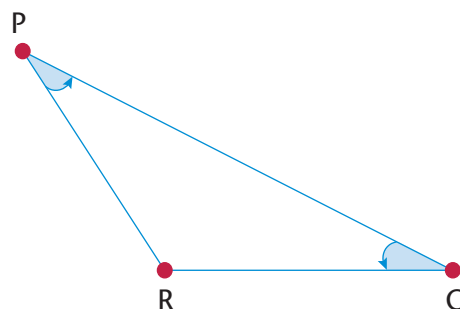
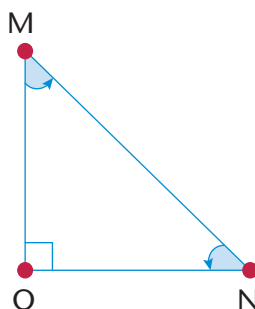
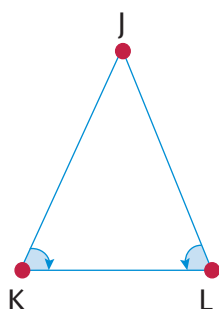

4. Copy the table below. Say for what kind of triangle each statement is true. If it is true for all triangles, then write “All triangles”.

Statement	True for:
(a) Two sides of the triangle are equal.	
(b) One angle of the triangle is obtuse.	
(c) Two angles of the triangle are equal.	
(d) All three angles of the triangle are equal to 60° .	
(e) The size of an exterior angle is equal to the sum of the opposite interior angles.	
(f) The longest side of the triangle is opposite the biggest angle.	
(g) The sum of the two shorter sides of the triangle is bigger than the length of the longest side.	
(h) The square of the length of one side is equal to the sum of the squares of the other sides.	
(i) The square of the length of one side is bigger than the sum of the squares of the other sides.	
(j) The sum of the interior angles of the triangle is 180° .	

11.2 Finding unknown angles in triangles

When you have to determine the size of an unknown angle or length of a shape in geometry, you must give a reason for each statement you make.

Complete the example below.

In $\triangle ABC$, $AC = BC$ and $\hat{C} = 40^\circ$. Find the size of \hat{B} (shown in the diagram as x).

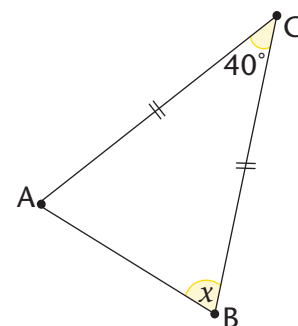

Statement	Reason
$AC = BC$	Given
$\therefore \hat{A} = \hat{B}$	
$180^\circ = 40^\circ + x + x$	Sum \angle s \triangle
$180^\circ - 40^\circ = 2x$	
$\therefore x =$	

FINDING UNKNOWN LENGTHS AND ANGLES

1. Calculate the sizes of the unknown angles.

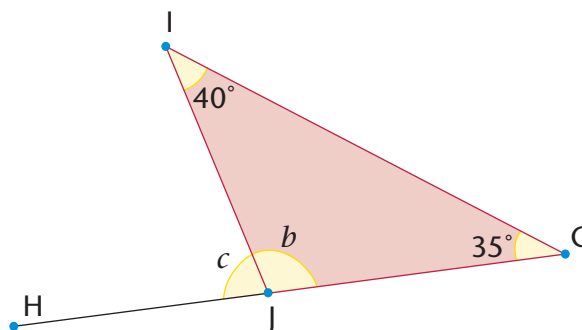
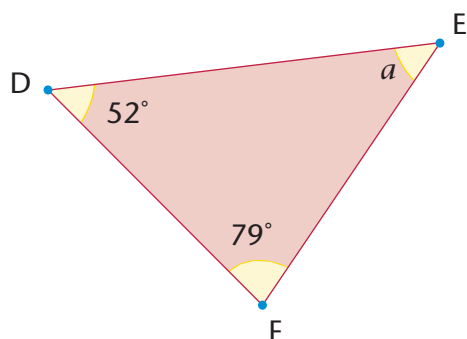

2. Determine the sizes of the unknown angles and the length of MO.

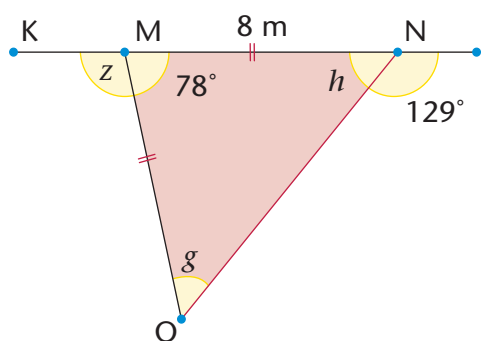
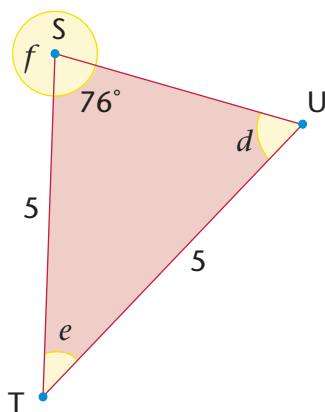

3. Calculate the sizes of y and x .

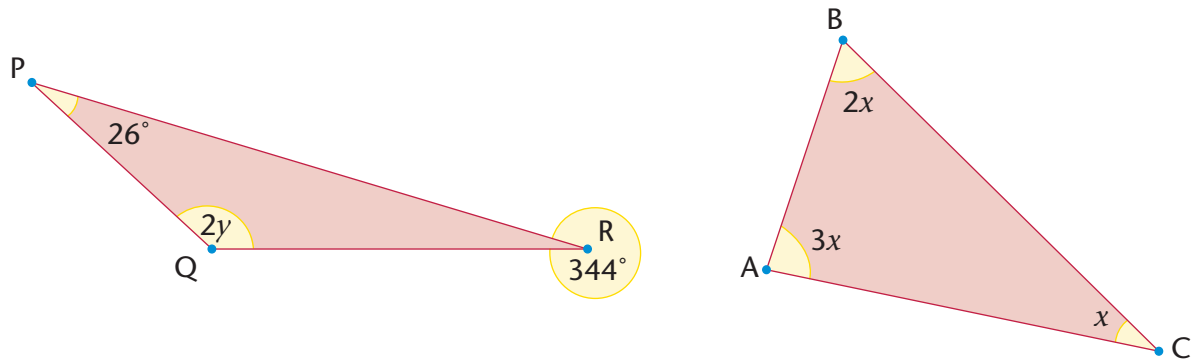

11.3 Quadrilaterals

PROPERTIES OF QUADRILATERALS

1. Name the following quadrilaterals. Copy the quadrilaterals and mark equal angles and equal sides in each figure. Use your ruler and protractor to measure angle sizes and lengths where necessary.

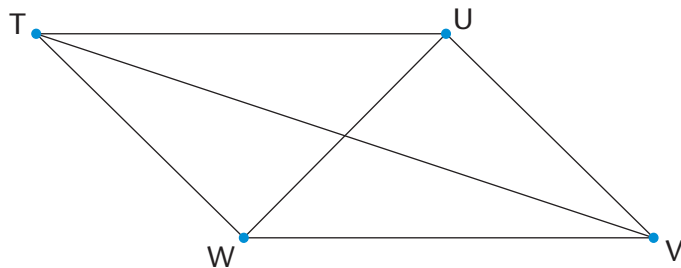
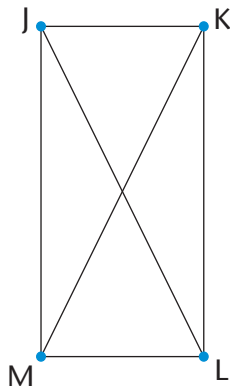
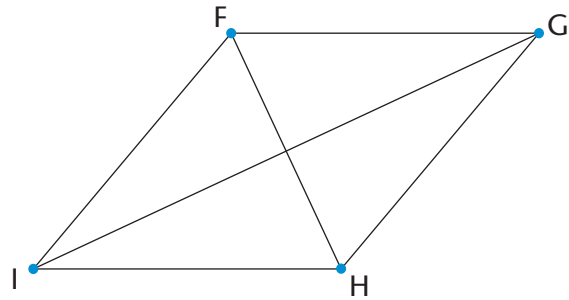
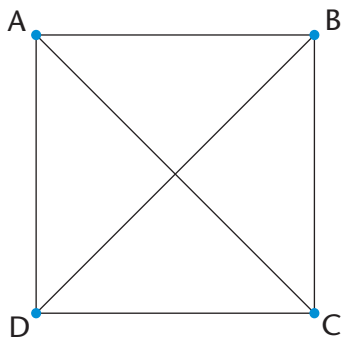

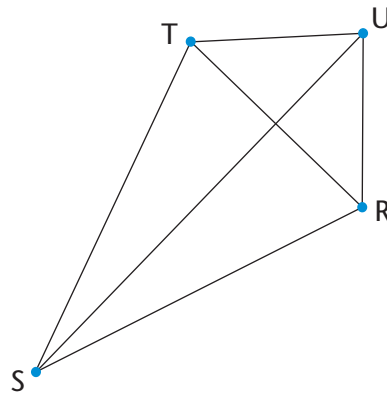
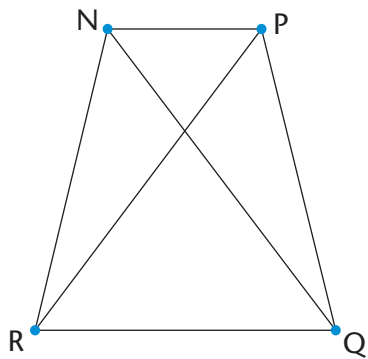

2. Copy and complete the following table:

Properties	True for the following quadrilaterals					
	Square	Rhombus	Rectangle	Parallelogram	Kite	Trapezium
At least one pair of opposite angles is equal.	yes	yes	yes	yes	yes	no
Both pairs of opposite angles are equal.						
At least one pair of adjacent angles is equal.						
All four angles are equal.						
Any two opposite sides are equal.						
Two adjacent sides are equal and the other two adjacent sides are also equal.						
All four sides are equal.						
At least one pair of opposite sides is parallel.						
Any two opposite sides are parallel.						
The two diagonals are perpendicular.						
At least one diagonal bisects the other one.						

The two diagonals bisect each other.						
The two diagonals are equal.						
At least one diagonal bisects a pair of opposite angles.						
Both diagonals bisect a pair of opposite angles.						
The sum of the interior angles is 360° .						

3. Look at the properties of a square and a rhombus.

- Are all the properties of a square also the properties of a rhombus? Explain.
- Are all the properties of a rhombus also the properties of a square? Explain.
- Which statement is true? Write down the statement.

A square is a special kind of rhombus.

A rhombus is a special kind of square.

4. Look at the properties of rectangles and squares.

- Are all the properties of a square also the properties of a rectangle? Explain.
- Are all the properties of a rectangle also the properties of a square? Explain.
- Which statement is true? Write down the statement.

A square is a special kind of rectangle.

A rectangle is a special kind of square.

5. Look at the properties of parallelograms and rectangles.

- Are all the properties of a parallelogram also the properties of a rectangle? Explain.
- Are all the properties of a rectangle also the properties of a parallelogram? Explain.
- Which statement is true? Write down the statement.

A rectangle is a special parallelogram.

A parallelogram is a special rectangle.

6. Look at the properties of a rhombus and a parallelogram. Is a rhombus a special kind of parallelogram? Explain.

7. Compare the properties of a kite and a parallelogram. Why is a kite not a special kind of parallelogram?

8. Compare the properties of a trapezium and a parallelogram. Why is a trapezium not a special kind of parallelogram?

UNKNOWN SIDES AND ANGLES IN QUADRILATERALS

- Determine the sizes of angles a to e in the quadrilaterals below. Give reasons for your answers.

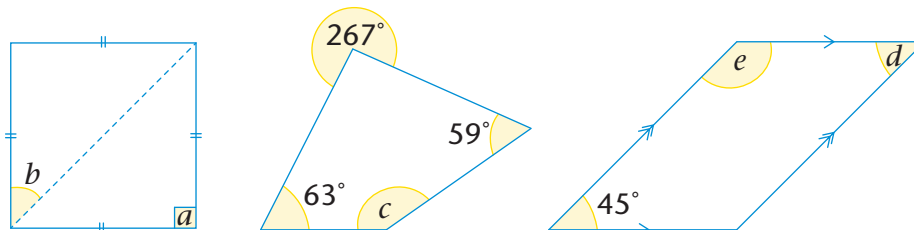

- Calculate the perimeters of the quadrilaterals on the right. Give your answers to two decimal places.

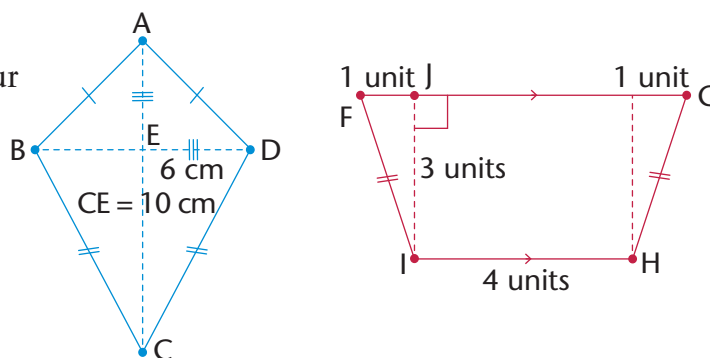

11.4 Congruent triangles

DEFINITION AND NOTATION OF CONGRUENT TRIANGLES

If two triangles are congruent, then they have exactly the same size and shape. In other words, if you cut out one of the triangles and place it on the other, they will match exactly.

If you know that two triangles are congruent, then each side in the one triangle will be equal to each corresponding side in the second triangle. Also, each angle in the one triangle will be equal to each corresponding angle in the second triangle.

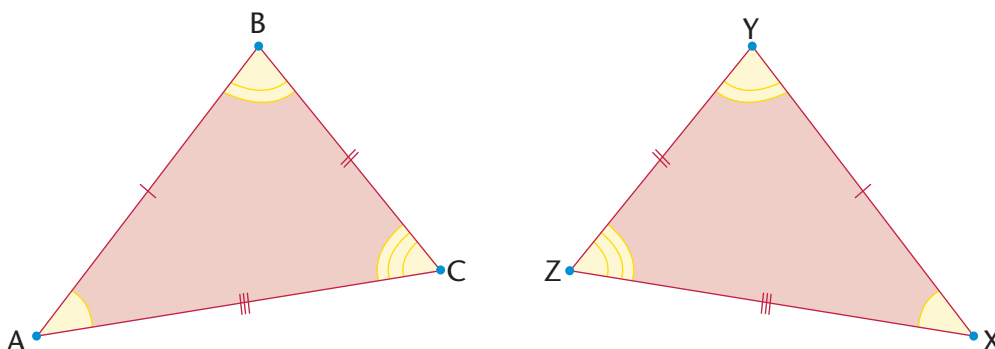

In the triangles on the previous page, you can see that $\triangle ABC \equiv \triangle XYZ$.

Congruency symbol

\equiv means “is congruent to”.

The order in which you write the letters when stating that two triangles are congruent is very important. The letters of the corresponding vertices between the two triangles must appear in the same position in the notation. For example, the notation for the triangles on the previous page should be: $\triangle ABC \equiv \triangle XYZ$, because it indicates that $\hat{A} = \hat{X}$, $\hat{B} = \hat{Y}$, $\hat{C} = \hat{Z}$, $AB = XY$, $BC = YZ$ and $AC = XZ$.

It is incorrect to write $\triangle ABC \equiv \triangle ZYX$. Although the letters refer to the same triangles, this notation indicates that $\hat{A} = \hat{Z}$, $\hat{C} = \hat{X}$, $AB = ZY$ and $BC = YX$, and these statements are not true.

Write down the equal angles and sides according to the following notations:

1. $\triangle KLM \equiv \triangle PQR$
2. $\triangle FGH \equiv \triangle CST$

MINIMUM CONDITIONS FOR CONGRUENT TRIANGLES

Earlier in this chapter, you investigated the minimum conditions that must be satisfied in order to establish that two triangles are congruent.

The conditions for congruency consist of:

- SSS (all corresponding sides are equal)
- SAS (two corresponding sides and the angle between the two sides are equal)
- AAS (two corresponding angles and any corresponding side are equal)
- RHS (both triangles have a 90° angle and have equal hypotenuses and one other side equal).

Decide whether or not the triangles in each pair below are congruent. For each congruent pair, write the notation correctly and give a reason for congruency.

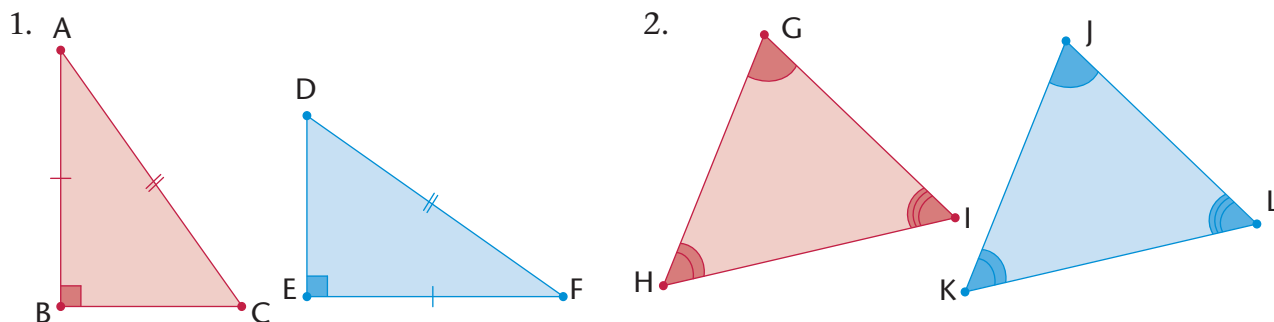

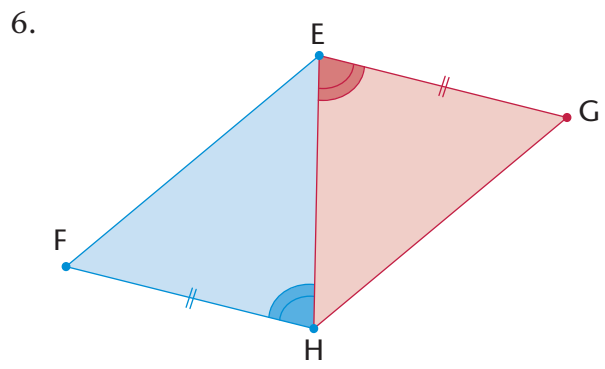
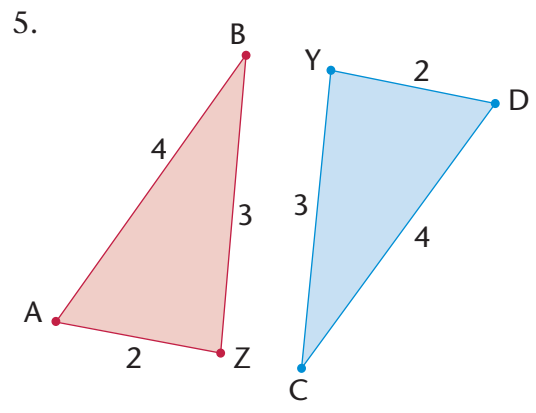
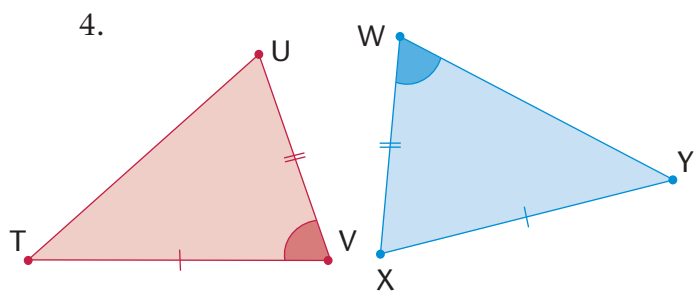
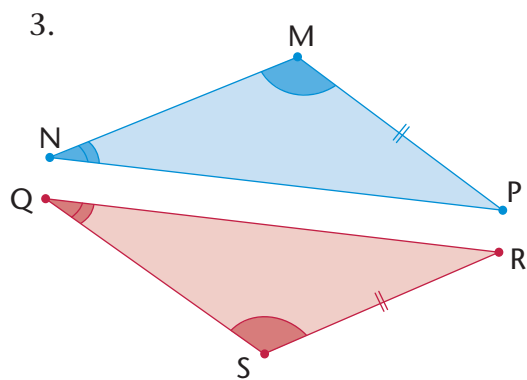

PROVING THAT TRIANGLES ARE CONGRUENT

You can use what you know about the minimum conditions for congruency to prove that two triangles are congruent.

- When giving a proof for congruency, remember the following:
- Each statement you make needs a reason.
 - You must give three statements to prove any two triangles congruent.
 - Give the reason for congruency.

Example:

In the sketch on the right: $AB \parallel EC$ and $AD = DC$.
Prove that the triangles are congruent.

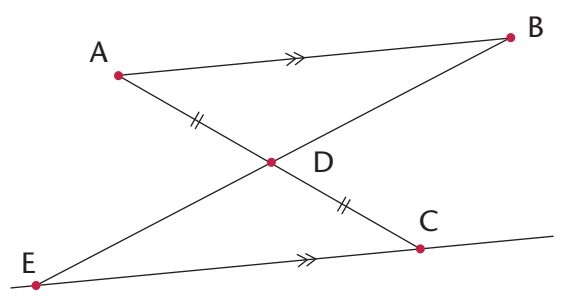

Solution:

Statement	Reason
In $\triangle ABD$ and $\triangle CED$:	
1) $AD = DC$	Given
2) $\hat{A}DB = \hat{C}DE$	Vert. opp. \angle s
3) $\hat{B}AD = \hat{E}CD$	Alt. \angle s ($AB \parallel EC$)
$\therefore \triangle ABD \cong \triangle CED$	AAS

1. Copy the table with the sketch, and prove that $\triangle ACE \cong \triangle BDE$.

	Statement	Reason

2. Copy the table with the sketch, and prove that $\triangle WXZ \cong \triangle YXZ$.

	Statement	Reason

3. Copy the table with the sketch, and prove that $QR = SP$. (Hint: First prove that the triangles are congruent.)

	Statement	Reason

4. Copy the table with the sketch, and prove that the triangles below are congruent. Then find the size of \widehat{QMP} .

	Statement	Reason

11.5 Similar triangles

PROPERTIES OF SIMILAR TRIANGLES

$\triangle BAC$ and $\triangle DEF$ below are similar to each other. Similar figures have the same shape, but their sizes can be different.

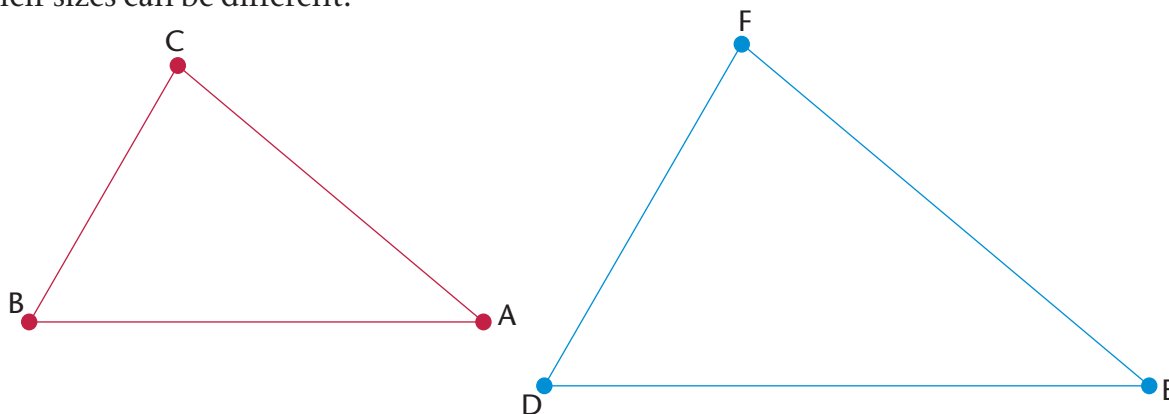

1. (a) Use a protractor to measure the angles in each triangle on the previous page. Then copy and complete the following table:

Angle	Angle	What do you notice?
$\hat{B} =$	$\hat{D} =$	
$\hat{A} =$	$\hat{E} =$	
$\hat{C} =$	$\hat{F} =$	

- (b) What can you say about the sizes of the angles in similar triangles?
2. (a) Use a ruler to measure the lengths of the sides in each triangle in question 1. Then copy and complete the following table:

Length (cm)	Length (cm)	Ratio
BA =	DE =	BA : DE = $1 : 1\frac{1}{3}$
BC =	DF =	BC : DF = =
CA =	FE =	CA : FE = =

- (b) What can you say about the relationship between the sides in similar triangles?
3. The following notation shows that the triangles are similar: $\triangle BAC \parallel \triangle DEF$. Why do you think we write the first triangle as $\triangle BAC$ and not as $\triangle ABC$?

Ratio reminder

You read $2 : 1$ as “two to one”.

The properties of similar triangles:

- The corresponding angles are equal.
- The corresponding sides are in proportion.

Notation for similar triangles:

If $\triangle XYZ$ is similar to $\triangle PQR$, then we write: $\triangle XYZ \parallel \triangle PQR$.

As for the notation of congruent figures, the order of the letters in the notation of similar triangles indicates which angles and sides are equal.

For $\triangle XYZ \parallel \triangle PQR$:

Angles: $\hat{X} = \hat{P}$, $\hat{Y} = \hat{Q}$ and $\hat{Z} = \hat{R}$

Sides: $XY : PQ = XZ : PR = YZ : QR$

If the triangles' vertices were written in a different order, then the statements above would not be true.

When proving that triangles are similar, you either need to show that the corresponding angles are equal, or you must show that the sides are in proportion.

WORKING WITH PROPERTIES OF SIMILAR TRIANGLES

1. Decide if the following triangles are similar to each other:

(a)

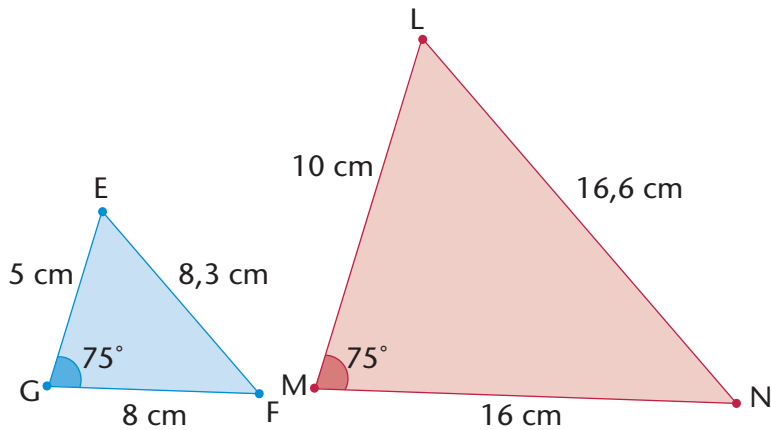

(b)

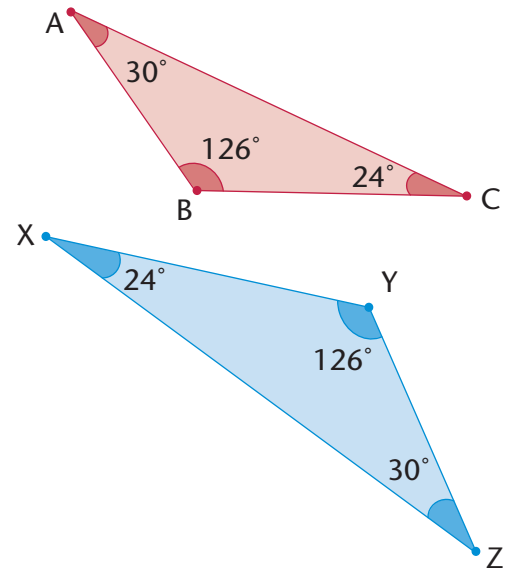

(c)

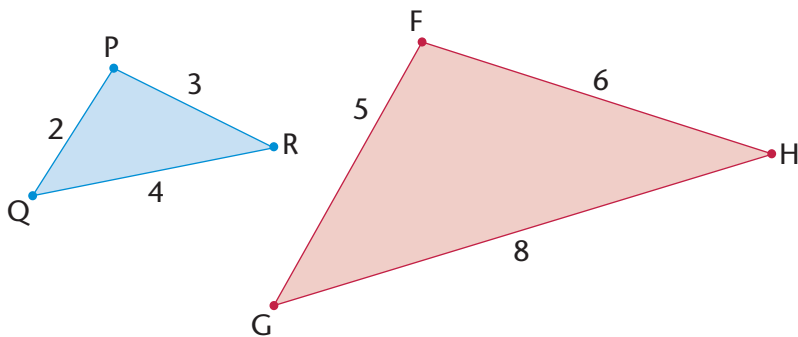

(d)

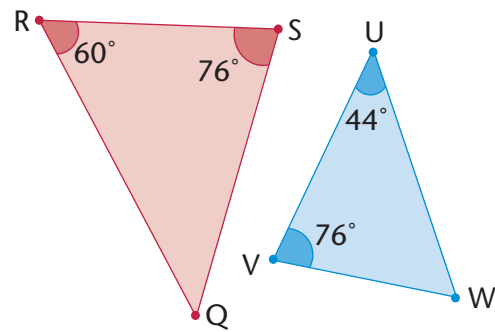

2. Do the following task:

- Use a ruler and protractor to construct the triangles described in (a) to (d) on the next page.
- Use your knowledge of similarity to draw the second triangle in each question.
- Indicate the sizes of the corresponding sides and angles on the second triangle.

- (a) In $\triangle EFG$, $\hat{G} = 75^\circ$, $EG = 4$ cm and $GF = 5$ cm.
 $\triangle ABC$ is an enlargement of $\triangle EFG$, with its sides three times longer.
- (b) In $\triangle MNO$, $\hat{M} = 45^\circ$, $\hat{N} = 30^\circ$ and $MN = 5$ cm.
 $\triangle PQR$ is similar to $\triangle MNO$. The sides of $\triangle MNO$ to $\triangle PQR$ are in proportion $1 : 3$.
- (c) $\triangle RST$ is an isosceles triangle. $\hat{R} = 40^\circ$, RS is 10 cm and $RS = RT$.
 $\triangle VWX$ is similar to $\triangle RST$. The sides of $\triangle RST$ to $\triangle VWX$ are in proportion $1 : \frac{1}{2}$.
- (d) $\triangle KLM$ is right-angled at \hat{L} , LM is 7 cm and the hypotenuse is 12 cm.
 $\triangle XYZ$ is similar to $\triangle KLM$, so that the sides are a third of the length of $\triangle KLM$.

INVESTIGATION: MINIMUM CONDITIONS FOR SIMILARITY

Which of the following are minimum conditions for similar triangles?

- (a) Two angles in one triangle are equal to two angles in another triangle.

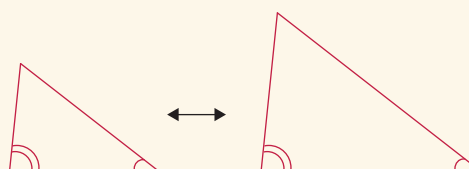

- (b) Two sides of one triangle are in the same proportion as two sides in another triangle.

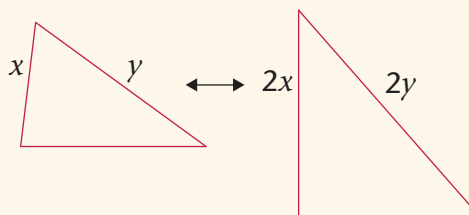

- (c) Two sides of one triangle are in the same proportion as two sides in another triangle, and the angle between the two sides is equal to the angle between the corresponding sides.

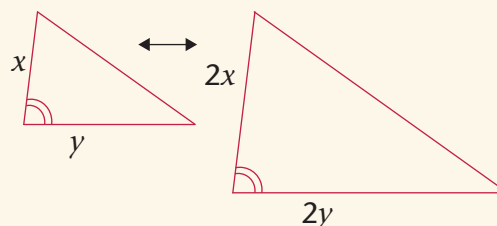

- (d) Two sides of one triangle are in the same proportion as two sides in another triangle, and one angle not between the two sides is equal to the corresponding angle in the other triangle.

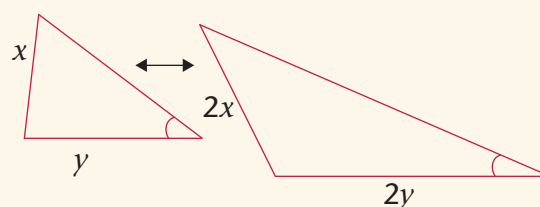

SOLVING PROBLEMS WITH SIMILAR TRIANGLES

1. Line segment QR is parallel to line segment ST.

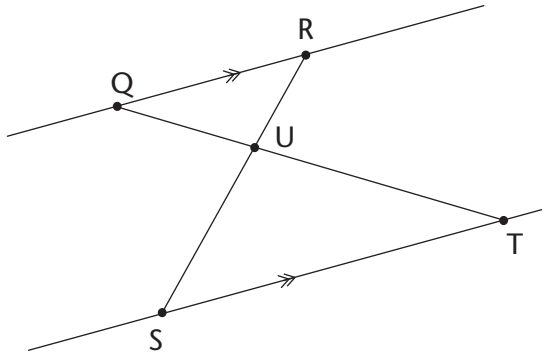

Parallel lines never meet. Two lines are parallel to each other if the distance between them is the same along the whole length of the lines.

Copy and complete the following proof that $\triangle QRU \parallel \triangle TSU$:

Statement	Reason
$\widehat{RQT} = \widehat{QTS}$	Alt. \angle s (QR \parallel ST)
$\widehat{QRS} =$	
$=$	Vert. opp. \angle s
$\therefore \triangle QRU \parallel \triangle TSU$	Equal \angle s (or AAA)

2. The following intersecting line segments form triangle pairs between parallel lines.

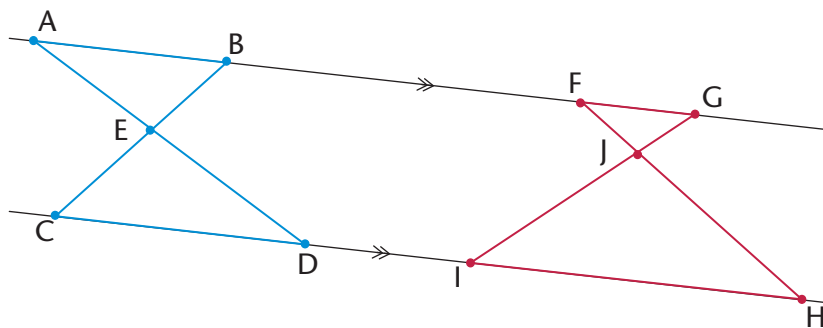

- Are the triangles in each pair similar? Explain.
- Write down pairs of similar triangles.
- Are triangles like these always similar? Explain how you can be sure without measuring every possible triangle pair.

3. The intersecting lines on the right form triangle pairs between the line segments that are not parallel. Are these triangle pairs similar? Explain why or why not.

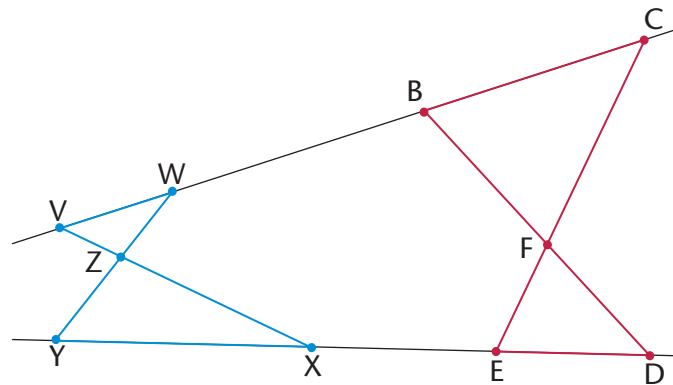

4. Consider the triangles below. $DE \parallel BC$. Copy the table with the sketch, and prove that $\triangle ABC \sim \triangle ADE$.

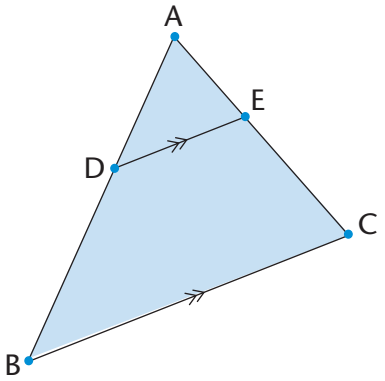
	Statement	Reason

5. In the diagram on the right, ST is a telephone pole and UV is a vertical stick. The stick is 1 m high and it casts a shadow of 1,7 m (VW). The telephone pole casts a shadow of 5,1 m (TW). Use similar triangles to calculate the height of the telephone pole.

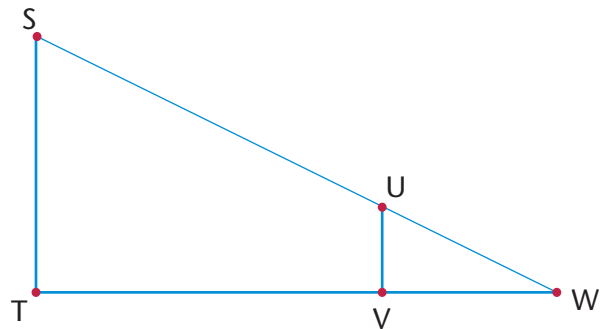

6. How many similar triangles are there in the diagram below? Explain your answer.

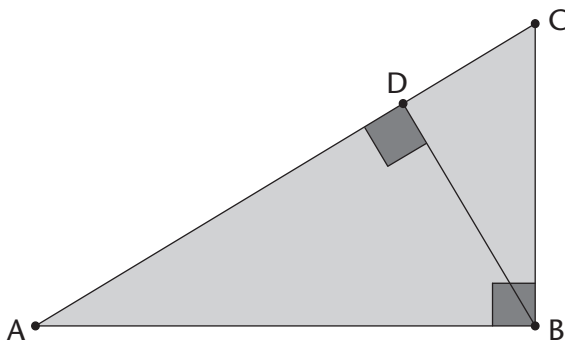

11.6 Extension questions

- $\triangle ABC$ on the right is equilateral. D is the midpoint of AB, E is the midpoint of BC and F is the midpoint of AC.
 - Prove that $\triangle BDE$ is an equilateral triangle.
 - Find all the congruent triangles. Give a proof for each.
 - Name as many similar triangles as you can. Explain how you know they are similar.
 - What is the proportion of the corresponding sides of the similar triangles?
 - Prove that DE is parallel to AC.
 - Is DF parallel to BC? Is EF parallel to BA? Explain.

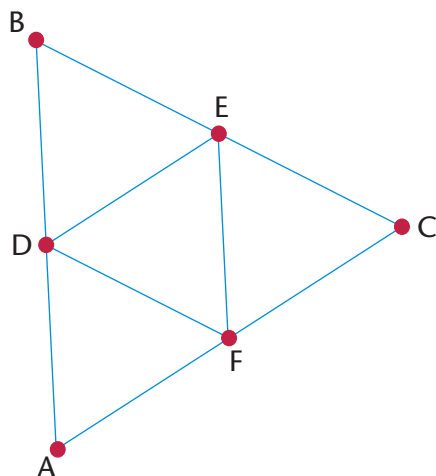

- Consider the similar triangles drawn below using concentric circles. Explain why the triangles are similar in each diagram.

(a)

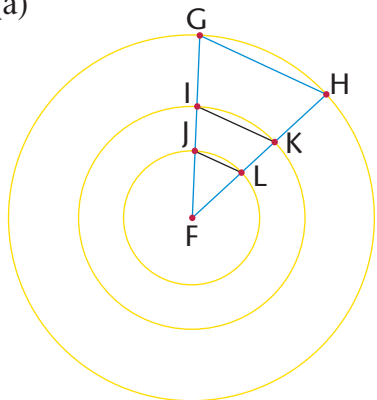

(b)

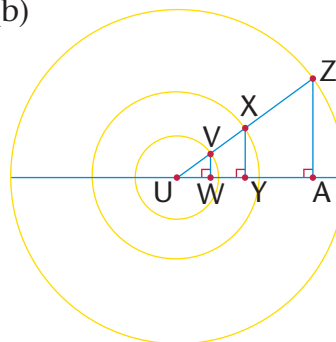

CHAPTER 12

Geometry of straight lines

12.1 Angle relationships

Remember that 360° is one full revolution.

If you look at something and then turn all the way around so that you are looking at it again, you have turned through an angle of 360° . If you turn only halfway around so that you look at something that was right behind your back, you have turned through an angle of 180° .

1. Answer the questions about the figure below.

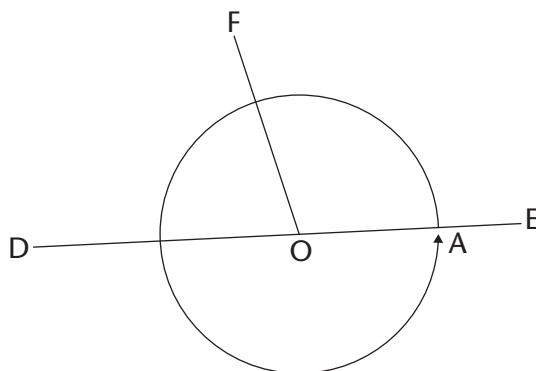

- (a) Is angle FOD in the figure smaller or bigger than a right angle?
- (b) Is angle FOE in the above figure smaller or bigger than a right angle?

In the figure above, $\widehat{FOD} + \widehat{FOE} = \text{half of a revolution} = 180^\circ$.

The sum of the angles on a straight line is 180° .

When the sum of angles is 180° , the angles are called **supplementary**.

2. \widehat{CMA} in the figure on the right is 75° .

AMB is a straight line.

- (a) How big is \widehat{CMB} ?
- (b) Why do you say so?

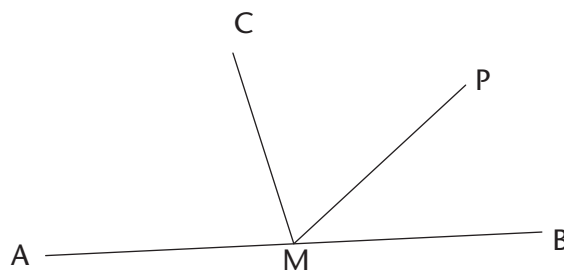

3. \widehat{PMB} in the figure in question 2 is 40° .
- How big is \widehat{CMP} ?
 - Explain your reasoning.
4. In the figure below, AMB is a straight line and \widehat{AMC} and \widehat{BMC} are equal angles.
- How big are these angles?
 - How do you know this?

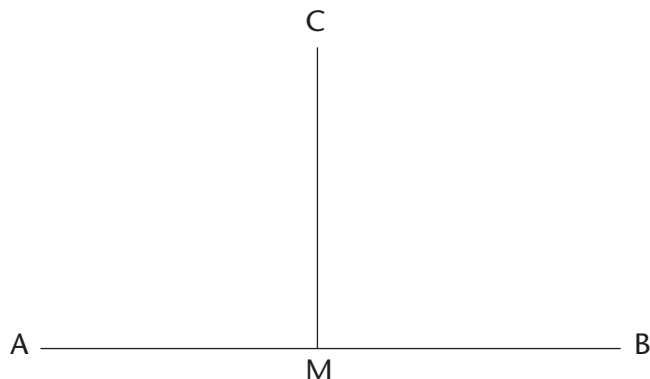

When one line forms two equal angles where it meets another line, the two lines are said to be **perpendicular**.

Because the two equal angles are angles on a straight line, their sum is 180° , hence each angle is 90° .

5. In the figure below, lines AB and CD intersect at point M .

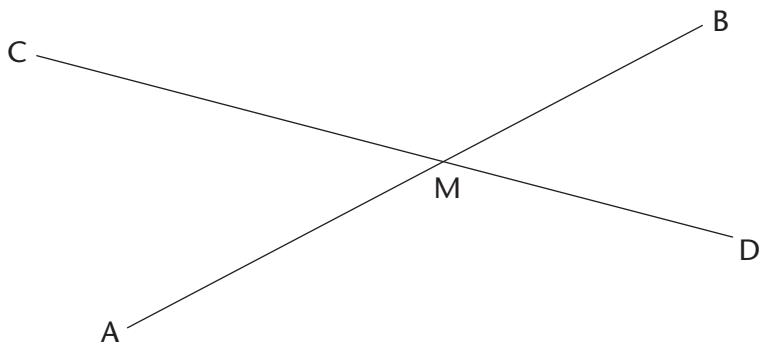

- Does it look as if \widehat{CMA} and \widehat{BMD} are equal?
- Can you explain why they are equal?
- What does $\widehat{CMA} + \widehat{DMA}$ equal? Why do you say so?
- What is $\widehat{CMA} + \widehat{CMB}$? Why do you say so?

In this chapter, you are required to give good reasons for every statement you make.

- (e) Is it true that $\widehat{CMA} + \widehat{DMA} = \widehat{CMA} + \widehat{CMB}$?
- (f) Which angle occurs on both sides of the equation in (e)?
6. Look carefully at your answers to questions 5(c) to (e).
Now try to explain your observation in question 5(a).
7. In the figure below, AB and CD intersect at M. Four angles are formed. Angle CMB and angle AMD are called **vertically opposite** angles. Angle CMA and angle BMD are also **vertically opposite**.

When two straight lines intersect, the vertically opposite angles are equal.

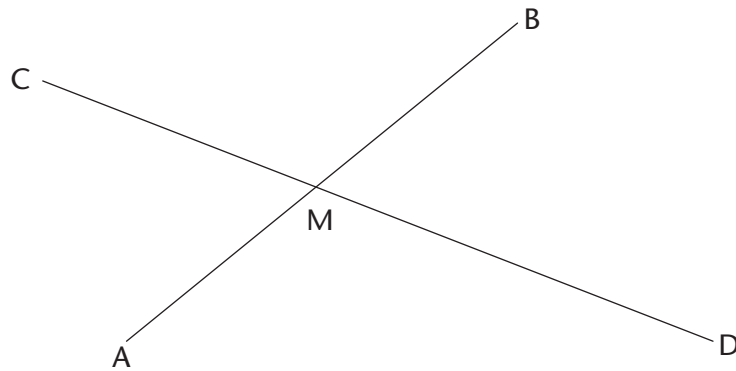

- (a) If angle BMC = 125° , how big is angle AMD?
- (b) Why do you say so?

LINES AND ANGLES

A line that intersects other lines is called a **transversal**.

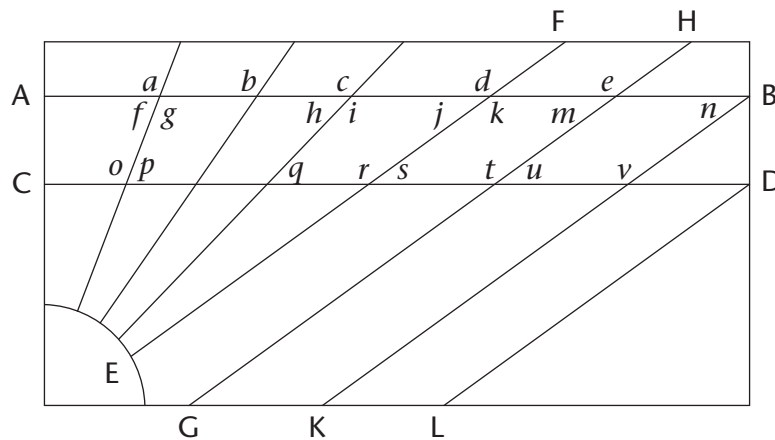

In the above pattern, AB is parallel to CD and $EF \parallel GH \parallel KB \parallel LD$.

- Angles a, b, c, d and e are **corresponding angles**. Do the corresponding angles appear to be equal?
- Investigate whether or not the corresponding angles are equal by using tracing paper. Trace the angle you want to compare to other angles and place it on top of the other angle to find out if they are equal. What do you notice?
- Angles f, h, j, m and n are also corresponding angles. Identify all the other groups of corresponding angles in the pattern.
- Describe the position of corresponding angles that are formed when a transversal intersects other lines.
- The following are pairs of **alternate angles**: g and o ; j and s ; and k and r . Do these angles appear to be equal?
- Investigate whether or not the alternate angles are equal by using tracing paper. Trace the angle you want to compare and place it on top of the other angle to find out if they are equal. What do you notice?
- Identify two more pairs of alternate angles.
- Clearly describe the relative position of alternate angles that are formed when a transversal intersects other lines.
- Did you notice anything about some of the pairs of corresponding angles when you did the investigation in question 6? Describe your finding.
- Angles f and o, i and q and k and s are all pairs of **co-interior angles**. Identify three more pairs of co-interior angles in the pattern.

The angles in the same relative position at each intersection where a straight line crosses two others are called **corresponding angles**.

Angles on different sides of a transversal and between two other lines are called **alternate angles**.

Angles on the same side of the transversal and between two other lines are called **co-interior angles**.

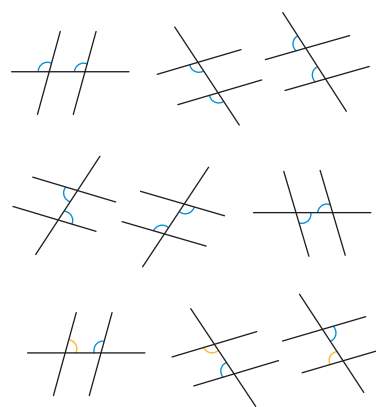

ANGLES FORMED BY PARALLEL LINES

Corresponding angles

The lines AB and CD shown on the following page never meet. Lines that never meet and are at a fixed distance from one another are called parallel lines. We write $AB \parallel CD$.

Parallel lines have the same direction, i.e. they form **equal corresponding angles** with any line that intersects them.

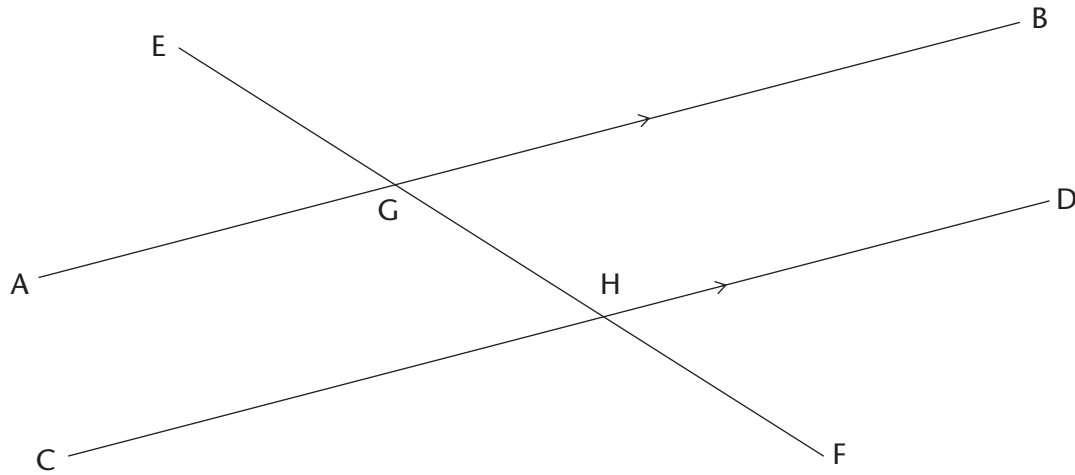

The line EF cuts AB at G and CD at H.

EF is a transversal that cuts parallel lines AB and CD.

- (a) Look carefully at the angles \widehat{EGA} and \widehat{EHC} in the above figure. They are called corresponding angles. Do they appear to be equal?
(b) Measure the two angles to check if they are equal. What do you notice?
- Suppose \widehat{EGA} and \widehat{EHC} are really equal. Would \widehat{EGB} and \widehat{EHD} then also be equal? Give reasons to support your answer.

When two parallel lines are cut by a transversal, the corresponding angles are equal.

Alternate angles

The angles \widehat{BGF} and \widehat{CHE} below are called alternate angles. They are on opposite sides of the transversal.

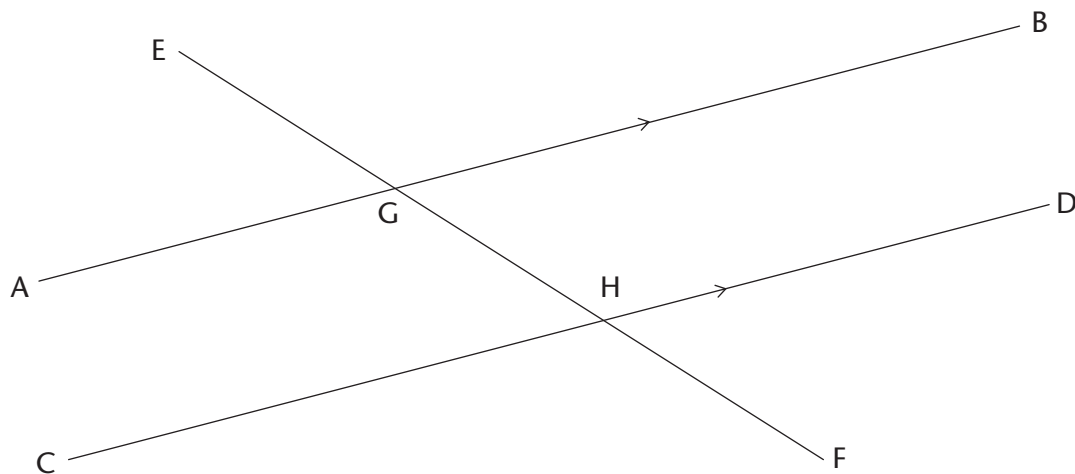

- Do you think angles AGF and DHE should also be called alternate angles?
- Do you think alternate angles are equal? Investigate by using the tracing paper like you did previously, or measure the angles accurately with your protractor. What do you notice?

When parallel lines are cut by a transversal, the alternate angles are equal.

- Try to explain why alternate angles are equal when the lines that are cut by a transversal are parallel, keeping in mind that corresponding angles are equal.

By answering the following questions, you should be able to see how you can explain why alternate angles are equal when parallel lines are cut by a transversal.

- Are angles \widehat{BGH} and \widehat{DHF} in the figure corresponding angles? What do you know about corresponding angles?

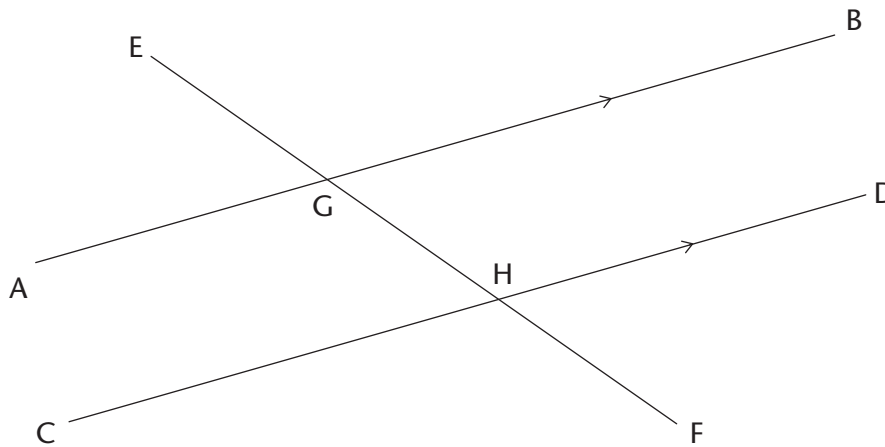

- What can you say about $\widehat{BGH} + \widehat{AGH}$? Give a reason.
 - What can you say about $\widehat{DHG} + \widehat{CHG}$? Give a reason.
 - Is it true that $\widehat{BGH} + \widehat{AGH} = \widehat{DHG} + \widehat{CHG}$? Explain.
 - Will the equation in (c) still be true if you replace angle \widehat{BGH} on the left-hand side with angle \widehat{CHG} ?
- Look carefully at your work in question 7 and write an explanation why alternate angles are equal, when two parallel lines are cut by a transversal.

Co-interior angles

The angles \widehat{AGH} and \widehat{CHG} in the figure on the following page are called co-interior angles. They are on the same side of the transversal.

The prefix "co-" means together. The word "co-interior" means on the same side.

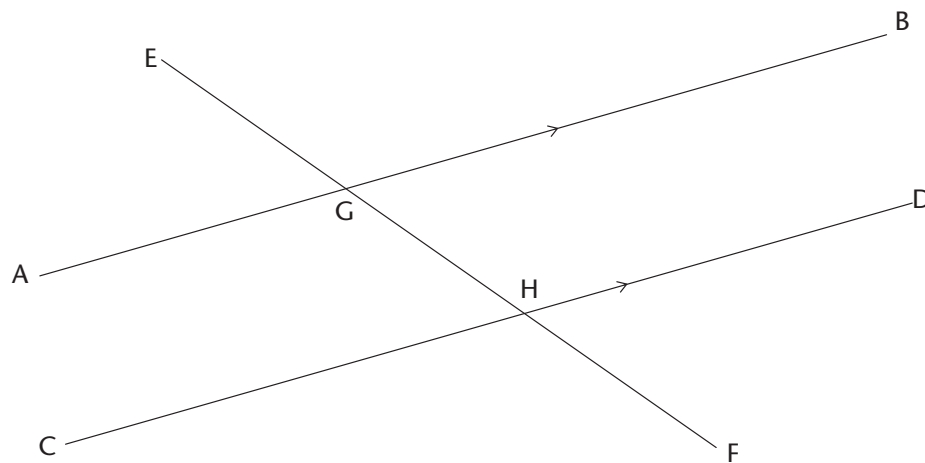

9. (a) What do you know about $\widehat{CHG} + \widehat{DHG}$? Explain.
 (b) What do you know about $\widehat{BGH} + \widehat{AGH}$? Explain.
 (c) What do you know about $\widehat{BGH} + \widehat{CHG}$? Explain.
 (d) What conclusion can you draw about $\widehat{AGH} + \widehat{CHG}$?
 Give detailed reasons for your conclusion.

When two parallel lines are cut by a transversal, the sum of two co-interior angles is 180° .

Another way of saying this is to say that the two co-interior angles are **supplementary**.

12.2 Identify and name angles

1. In the figure below, the line RF is perpendicular to AB.

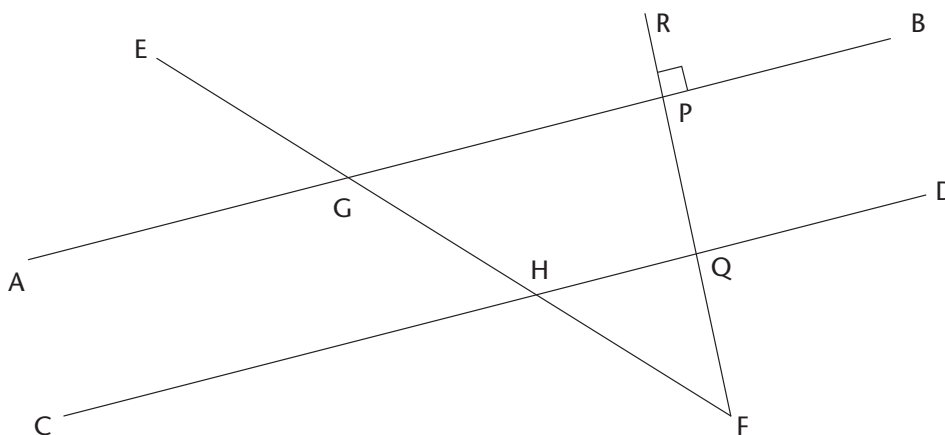

- (a) Is RF also perpendicular to CD? Justify your answer.
 (b) Name four pairs of supplementary angles in the figure. In each case, say how you know that the angles are supplementary.

- (c) Name four pairs of co-interior angles in the figure.
- (d) Name four pairs of corresponding angles in the figure.
- (e) Name four pairs of alternate angles in the figure.

2. Now you are given that AB and CD in the figure below are parallel.

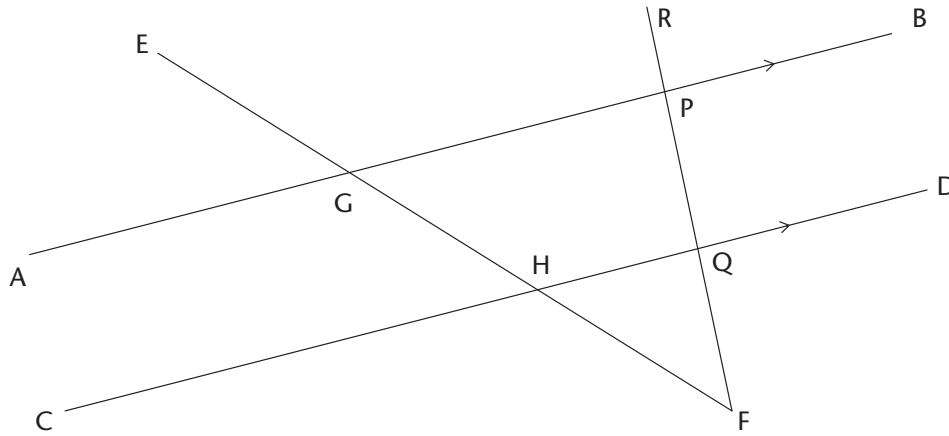

- (a) If it is also given that RF is perpendicular to AB, will RF also be perpendicular to CD? Justify your answer.
- (b) Name all pairs of supplementary angles in the figure. In each case, say how you know that the angles are supplementary.
- (c) Suppose $\widehat{E\hat{G}A} = x$. Give the size of as many angles in the figure as you can, in terms of x . Each time give a reason for your answer.

12.3 Solving problems

1. Line segments AB and CD in the figure below are parallel. EF and IJ are also parallel. Copy the figure and mark these facts on the figure, and then answer the questions.

When you solve problems in geometry you can use a shorthand way to write your reasons. For example, if two angles are equal because they are corresponding angles, then you can write (corr \angle s, AB \parallel CD) as the reason.

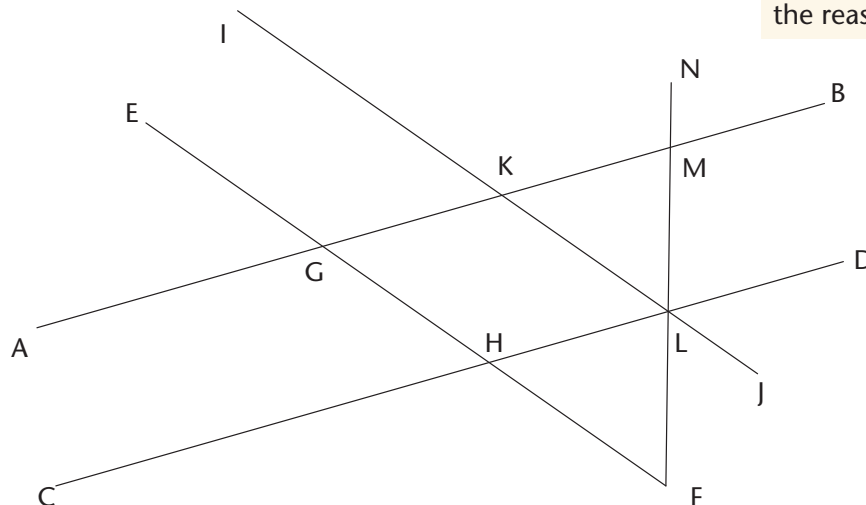

- (a) Name five angles in the figure that are equal to \widehat{GHD} . Give a reason for each of your answers.
- (b) Name all the angles in the figure that are equal to \widehat{AGH} . Give a reason for each of your answers.

2. AB and CD in the figure below are parallel. EF and IJ are also parallel. $\widehat{NMB} = 80^\circ$ and $\widehat{JLF} = 40^\circ$.

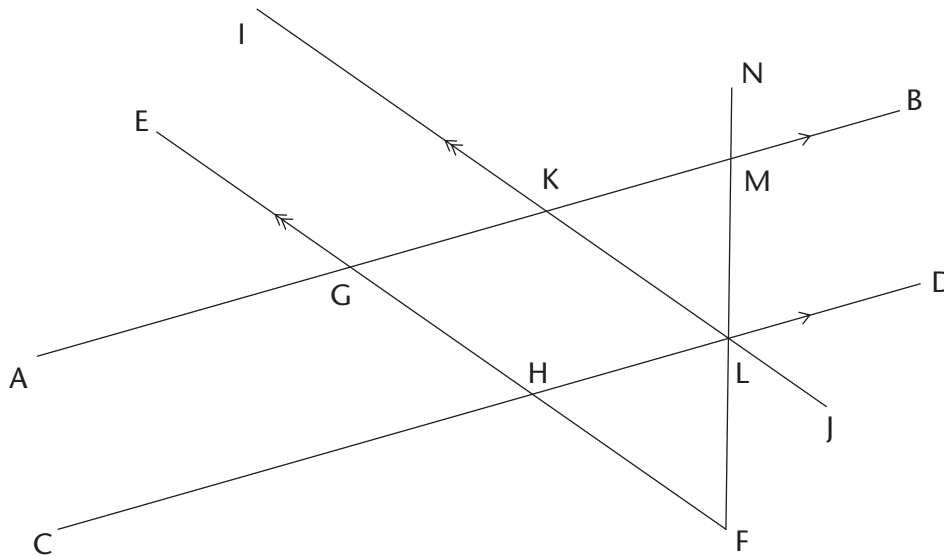

Find the sizes of as many angles in the figure as you can, giving reasons.

3. In the figure below, $AB \parallel CD$; $EF \parallel AB$; $JR \parallel GH$. You are also given that $\widehat{PMN} = 60^\circ$, $\widehat{RND} = 50^\circ$.

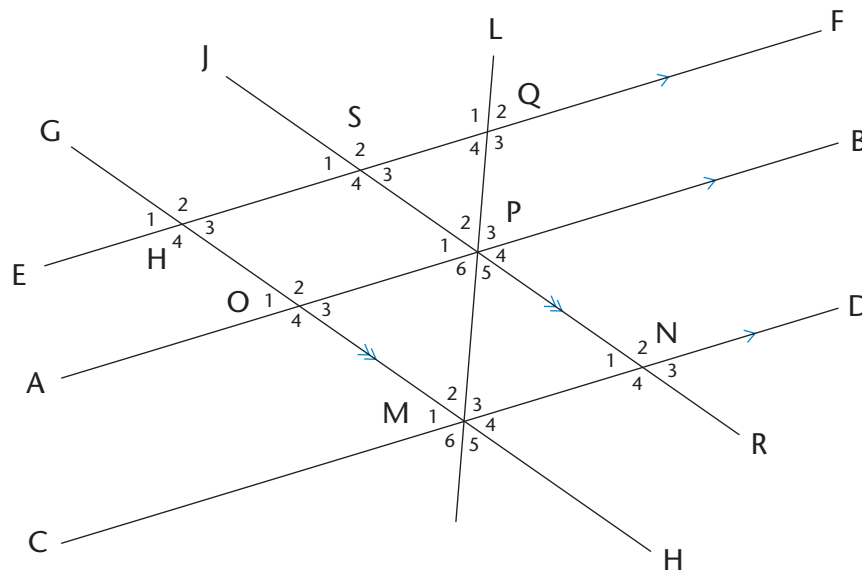

- (a) Find the sizes of as many angles in the figure as you can, giving reasons.
- (b) Are EF and CD parallel? Give reasons for your answers.

CHAPTER 13

Pythagoras' Theorem

13.1 Investigating the sides of a right-angled triangle

A **theorem** is a rule or a statement that has been proved through reasoning. **Pythagoras' Theorem** is a rule that applies only to **right-angled triangles**. The theorem is named after the Greek mathematician, Pythagoras.

A right-angled triangle has one 90° angle. The longest side of the right-angled triangle is called the **hypotenuse**.

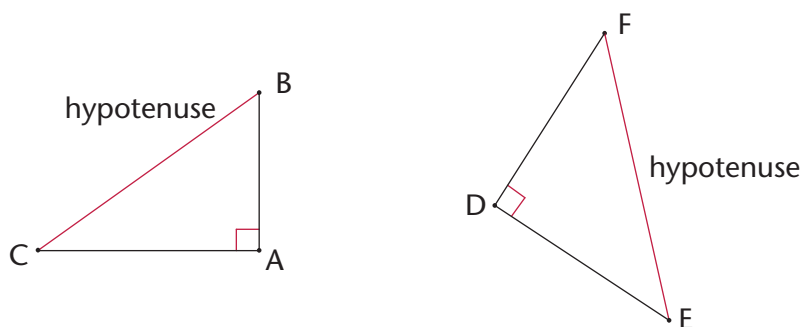

Pythagoras (569–475 BC)

Pythagoras was an influential mathematician. Like many Greek mathematicians of 2 500 years ago, he was also a philosopher and a scientist. He formulated the best-known theorem, today known as Pythagoras' Theorem.

However, the theorem had already been in use 1 000 years earlier, by the Chinese and the Babylonians.

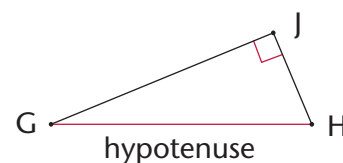

The hypotenuse is the side opposite the 90° angle in a right-angled triangle. It is always the longest side.

How to say it:

"high - pot - eh - news"

INVESTIGATING SQUARES ON THE SIDES OF RIGHT-ANGLED TRIANGLES

- The figure shows a right-angled triangle with squares on each of the sides.
 - Write down the areas of the following:
 - Square A
 - Square B
 - Square C
 - Add the area of square B and the area of square C.
 - What do you notice about the areas?

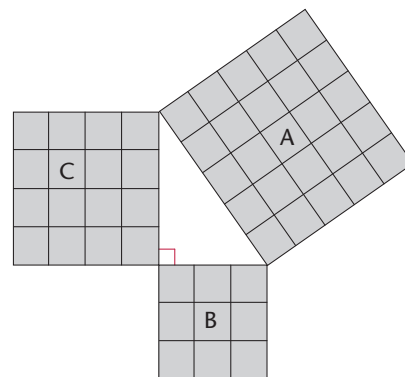

2. The figure below is similar to the one in question 1. The lengths of the sides of the right-angled triangle are 5 cm and 12 cm.

(a) What is the length of the hypotenuse? Count the squares.

(b) Use the squares to find the following:

Area of A

Area of B

Area of C

Area of B + Area of C

(c) What do you notice about the areas?

Is it similar to your answer in 1(c)?

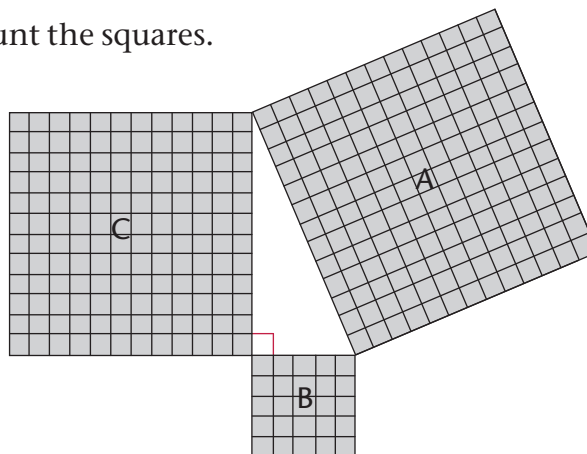

3. A right-angled triangle has side lengths of 8 cm and 15 cm. Use your findings in the previous questions to answer the following questions:

(a) What is the area of the square drawn along the hypotenuse?

(b) What is the length of the triangle's hypotenuse?

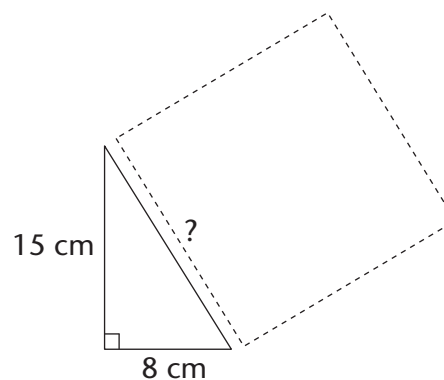

In the previous activity, you should have discovered Pythagoras' Theorem for right-angled triangles.

Pythagoras' Theorem says:

In a right-angled triangle, a square formed on the hypotenuse will have the same area as the sum of the area of the two squares formed on the other sides of the triangle. Therefore:

$$(\text{Hypotenuse})^2 = (\text{Side 1})^2 + (\text{Side 2})^2$$

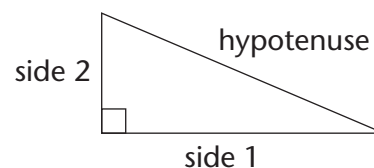

13.2 Checking for right-angled triangles

Pythagoras' Theorem applies in two ways:

- If a triangle is right-angled, the sides will have the following relationship:
 $(\text{Hypotenuse})^2 = (\text{Side 1})^2 + (\text{Side 2})^2$.
- If the sides have the relationship: $(\text{Longest side})^2 = (\text{Side 1})^2 + (\text{Side 2})^2$, then the triangle is a right-angled triangle.

So, we can test if any triangle is right-angled without using a protractor.

Example:

Is a triangle with sides 12 cm, 16 cm and 20 cm right-angled?

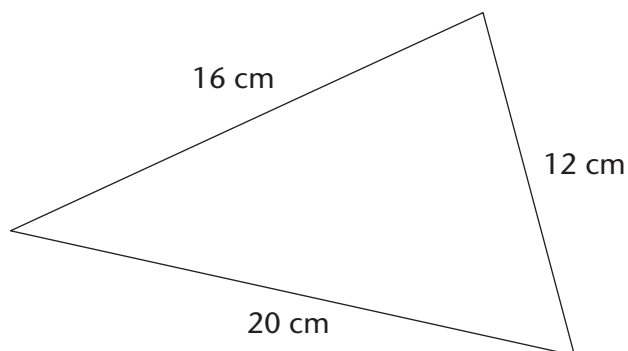

$$(\text{Longest side})^2 = 20^2 = 400 \text{ cm}^2$$

$$(\text{Side 1})^2 + (\text{Side 2})^2 = 12^2 + 16^2 = 144 + 256 = 400 \text{ cm}^2$$

$$(\text{Longest side})^2 = (\text{Side 1})^2 + (\text{Side 2})^2$$

∴ The triangle is right-angled.

ARE THESE RIGHT-ANGLED TRIANGLES?

1. This triangle's side lengths are 29 mm, 20 mm and 21 mm.
 - (a) Prove that it is a right-angled triangle.
 - (b) Copy the triangle and mark the right angle in the diagram.

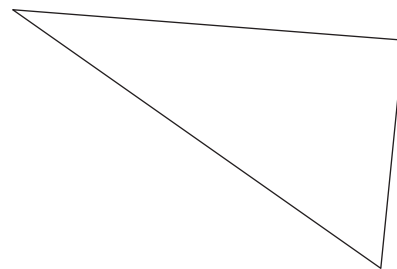

2. Use Pythagoras' Theorem to determine whether these triangles are right-angled. All values are in the same units.

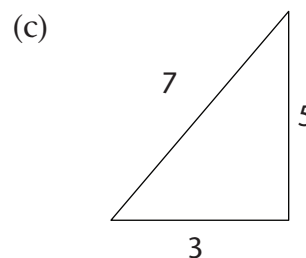
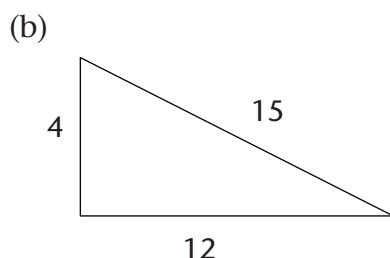
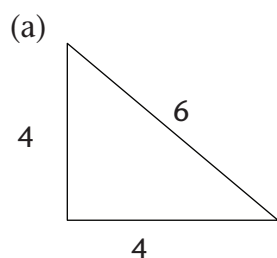

3. Determine whether the following side lengths would form right-angled triangles. All values are in the same units.
 - (a) 7, 9 and 12
 - (b) 7, 12 and 14
 - (c) 16, 8 and 10
 - (d) 6, 8 and 10
 - (e) 8, 15 and 17
 - (f) 16, 21 and 25

13.3 Finding missing sides

You can use the Pythagoras' Theorem to find the lengths of missing sides if you know that a triangle is right-angled.

FINDING THE MISSING HYPOTENUSE

Example: Calculate the length of the hypotenuse if the lengths of the other two sides are six units and eight units.

$\triangle ABC$ is right-angled, so:

$$\begin{aligned}AC^2 &= AB^2 + BC^2 \\ &= (6^2 + 8^2) \text{ units}^2 \\ &= 36 + 64 \text{ units}^2 \\ &= 100 \text{ units}^2 \\ AC &= \sqrt{100} \text{ units} \\ &= 10 \text{ units}\end{aligned}$$

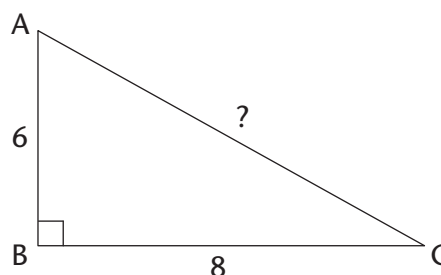

Sometimes the square root of a number is not a whole number or a simple fraction. In these cases, you can leave the answer under the square root sign. This form of the number is called a **surd**.

Example: Calculate the length of the hypotenuse of $\triangle ABC$ if $\hat{B} = 90^\circ$, $AB =$ two units and $BC =$ five units. Leave your answer in surd form, where applicable. Remember when taking the square root that length is always positive.

Surd form

You pronounce *surd* so that it rhymes with *word*.

$\sqrt{5}$ is an example of a number in surd form.

$\sqrt{9}$ is not a surd because you can simplify it:

$$\sqrt{9} = 3$$

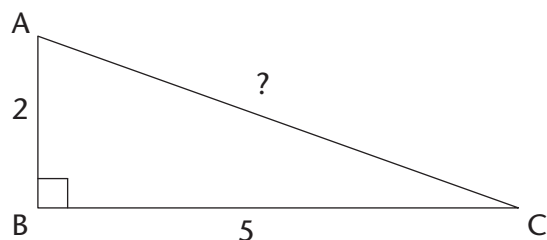

$$\begin{aligned}AC^2 &= AB^2 + BC^2 \\ &= 2^2 + 5^2 \text{ units}^2 \\ &= 4 + 25 \text{ units}^2 \\ &= 29 \text{ units}^2 \\ AC &= \sqrt{29} \text{ units}\end{aligned}$$

1. Find the length of the hypotenuse in each of the triangles shown on the following page. Leave the answers in surd form where applicable.

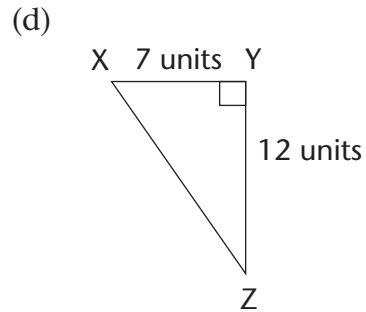
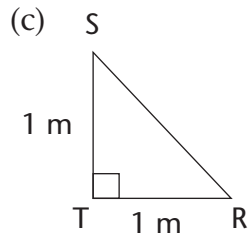
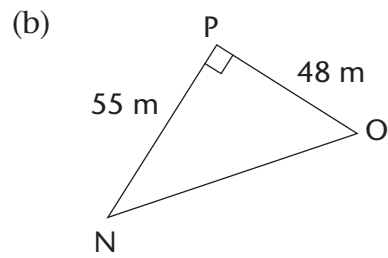
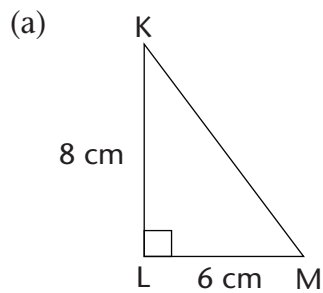

2. A rectangle has sides with lengths of 36 mm and 77 mm . Find the length of the rectangle's diagonal.

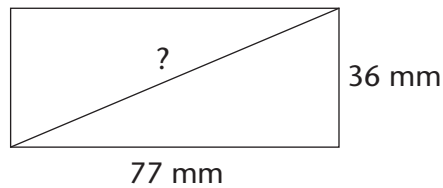

3. $\triangle ABC$ has $\hat{A} = 90^\circ$, $AB = 3\text{ cm}$ and $AC = 5\text{ cm}$. Make a rough sketch of the triangle, and then calculate the length of BC .
4. A rectangular prism is made of glass. It has a length of 16 cm , a height of 10 cm and a breadth of 8 cm . $ABCD$ and $EFGH$ are two of its faces. $\triangle ACH$ has been drawn inside the prism. Is $\triangle ACH$ right-angled? Answer the questions to find out.

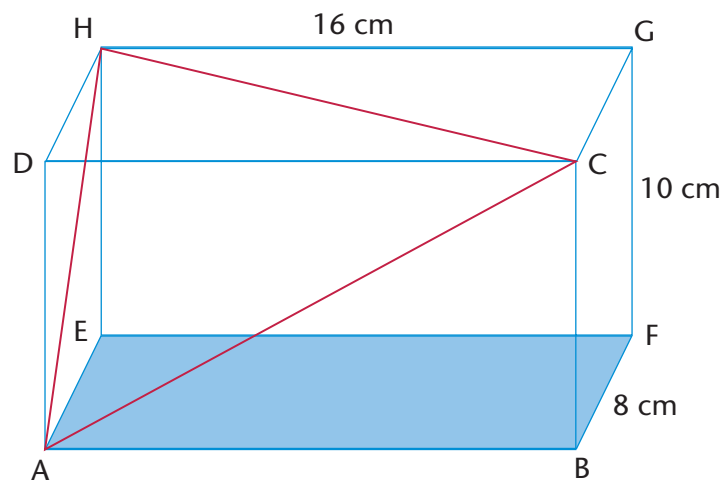

- (a) Calculate the length of the sides of $\triangle ACH$. Note that all three sides of the triangles are diagonals of rectangles. AC is in rectangle ABCD, AH is in ADHE and HC is in HDCG.
- (b) Is $\triangle ACH$ right-angled? Explain your answer.

FINDING ANY MISSING SIDE IN A RIGHT-ANGLED TRIANGLE

Example: Find the length of TS in the triangle below.

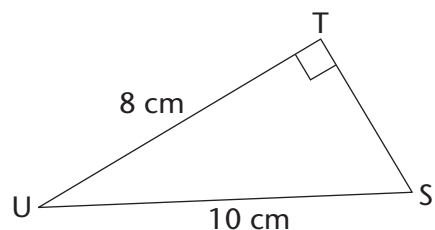

$$\begin{aligned} US^2 &= TU^2 + TS^2 \\ 10^2 &= 8^2 + TS^2 \\ 100 &= 64 + TS^2 \\ 36 &= TS^2 \\ \sqrt{36} &= TS \\ \therefore TS &= 6 \text{ cm} \end{aligned}$$

1. In the right-angled triangles below, calculate the length of the sides that have not been given. Leave your answers in surd form where applicable.

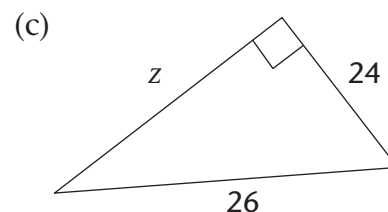
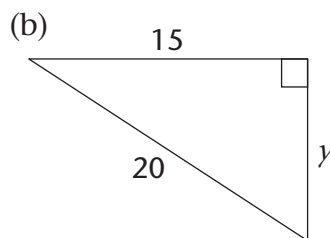
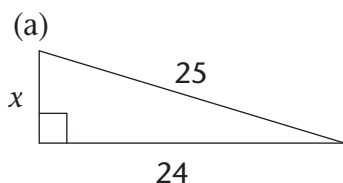

2. Calculate the length of the third side of each of the following right-angled triangles. First draw a rough sketch of each of the triangles before you do any calculations. Round off your answers to two decimal places.
- $\triangle ABC$ has $AB = 12$ cm, $BC = 18$ cm and $\hat{A} = 90^\circ$. Calculate AC.
 - $\triangle DEF$ has $\hat{F} = 90^\circ$, $DE = 58$ cm and $DF = 41$ cm. Calculate EF.
 - $\triangle JKL$ has $\hat{K} = 90^\circ$, $JK = 119$ m and $KL = 167$ m. Calculate JL.
 - $\triangle PQR$ has $PQ = 2$ cm, $QR = 8$ cm and $\hat{Q} = 90^\circ$. Calculate PR.
3. (a) A ladder with a length of 5 m is placed at an angle against a wall. The bottom of the ladder is 1 m away from the wall. How far up the wall will the ladder reach? Round off to two decimal places.
- (b) If the ladder reaches a height of 4,5 m against the wall, how far away from the wall was it placed? Round off to two decimal places.

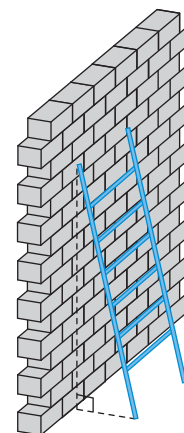

PYTHAGOREAN TRIPLES

Sets of **whole numbers** that can be used as the sides of a right-angled triangle are known as **Pythagorean triples**, for example:

3-4-5

5-12-13

7-24-25

16-30-34

20-21-29

You extend these triples by finding multiples of them. For examples, triples from the 3-4-5 set include the following:

3-4-5

6-8-10

9-12-15

12-16-20

There are many old writings that record Pythagorean triples. For example, from 1900 to 1600 BC, the Babylonians had already calculated very large Pythagorean triples, such as:

1 679-2 400-2 929.

How many Pythagorean triples can you find? What is the largest one you can find that is not a multiple of another one?

13.4 More practice using Pythagoras' Theorem

- Four lines have been drawn on the grid below. Each square is one unit long. Calculate the lengths of the lines: AB, CD, EF and GH. Do the calculations and write the answers in surd form.

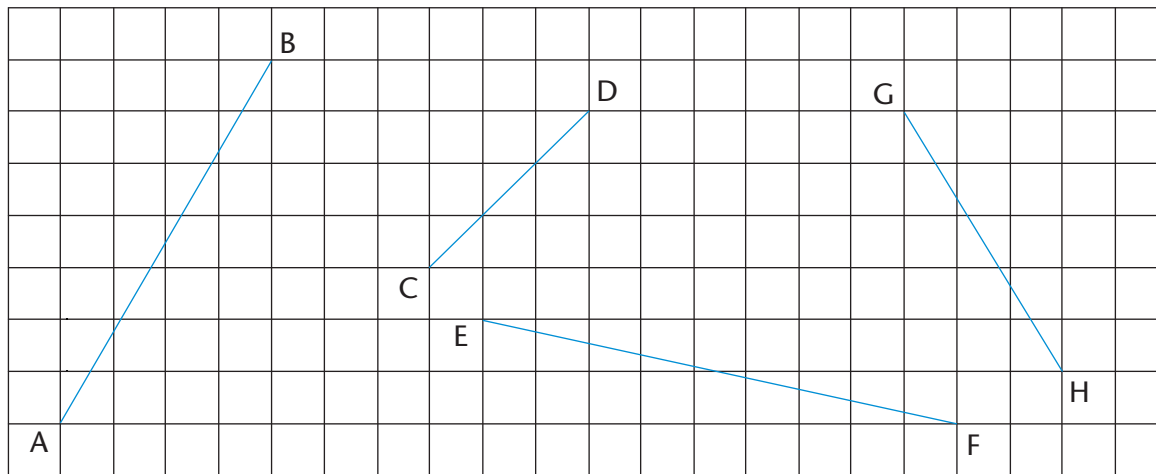

- Calculate the area of rectangle KLMN.
 - Calculate the perimeter of $\triangle KLM$.

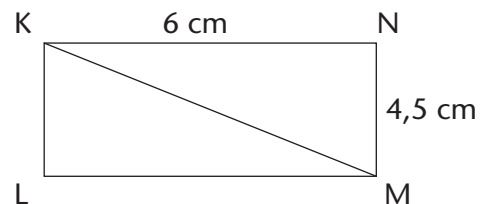

- ABCD is a rectangle with $AB = 4$ cm, $BC = 7$ cm and $CQ = 1,5$ cm. Round off your answers to two decimal places if the answers are not whole numbers.

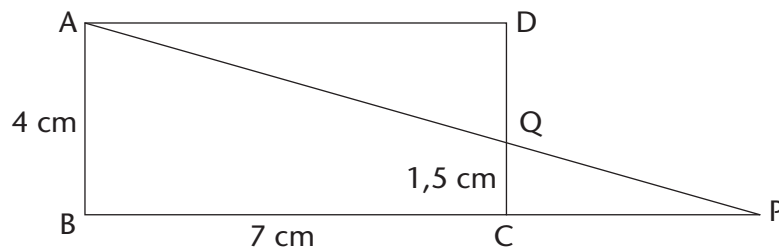

- What is the length of QD?
- If $CP = 4,2$ cm, calculate the length of PQ.
- Calculate the length of AQ and the area of ΔAQD .

4. MNST is a parallelogram. $NR = 9$ mm and $MR = 12$ mm.

- Calculate the area of ΔMNR .
- Calculate the perimeter of MNST.

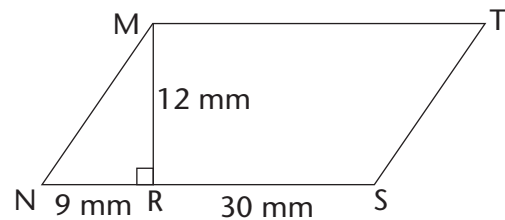

PYTHAGORAS' THEOREM AND OTHER TYPES OF TRIANGLES

Pythagoras' Theorem works only for right-angled triangles. But we can also use it to find out whether other triangles are acute or obtuse.

- If the square of the longest side is *less* than the sum of the squares of the two shorter sides, the *biggest angle is acute*.
For example, in a 6-8-9 triangle: $6^2 + 8^2 = 100$ and $9^2 = 81$.
81 is less than 100 \therefore the 6-8-9 triangle is acute.
- If the square of the longest side is *more* than the sum of the squares of the two shorter sides, the *biggest angle is obtuse*.
For example, in a 6-8-11 triangle: $6^2 + 8^2 = 100$ and $11^2 = 121$.
121 is more than 100 \therefore the 6-8-11 triangle is obtuse.

Copy and complete the following table. It is based on the triangle on the right. Decide whether each triangle described is right-angled, acute or obtuse.

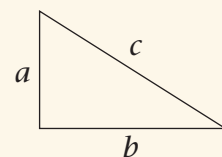

a	b	c	$a^2 + b^2$	c^2	Fill in =, > or <	Type of triangle
3	5	6	$3^2 + 5^2 = 9 + 25 = 34$	$6^2 = 36$	$a^2 + b^2 < c^2$	Acute
2	4	6			$a^2 + b^2 \dots\dots c^2$	
5	7	9			$a^2 + b^2 \dots\dots c^2$	
12	5	13			$a^2 + b^2 \dots\dots c^2$	
12	16	20	$12^2 + 16^2 = 144 + 256 = 400$	$20^2 = 400$	$a^2 + b^2 = c^2$	Right-angled
7	9	11			$a^2 + b^2 \dots\dots c^2$	
8	12	13			$a^2 + b^2 \dots\dots c^2$	

WORKSHEET

1. Write down Pythagoras' Theorem in the way that you best understand it.
2. Calculate the lengths of the missing sides in the following triangles. Leave the answers in surd form if necessary.

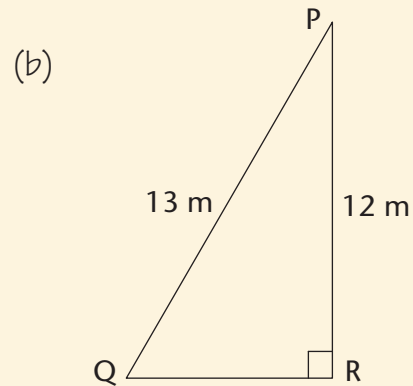
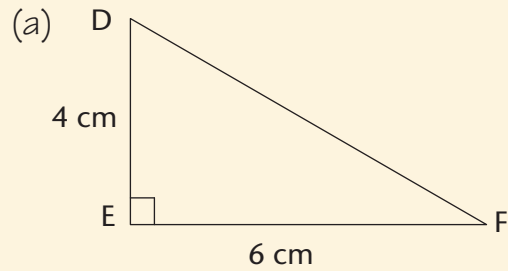

3. ABCD is a parallelogram.
 - (a) Calculate the perimeter of ABCD.
 - (b) Calculate the area of ABCD.

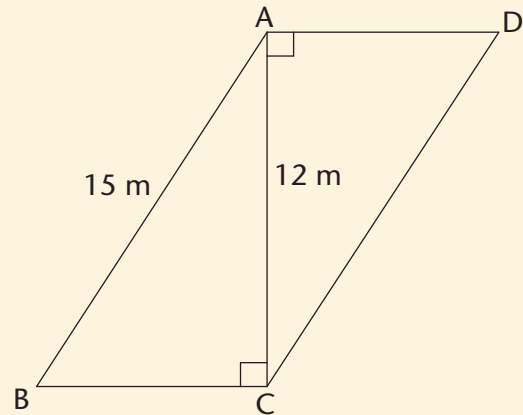

CHAPTER 14

Area and perimeter of 2D shapes

14.1 Area and perimeter of squares and rectangles

REVISING CONCEPTS

1. Each block in figures A to F below measures $1\text{ cm} \times 1\text{ cm}$. What is the perimeter and area of each of the figures?
Copy and complete the table below.

The **perimeter** (P) of a shape is the distance along the sides of the shape.
The **area** (A) of a figure is the size of the flat surface enclosed by the figure.

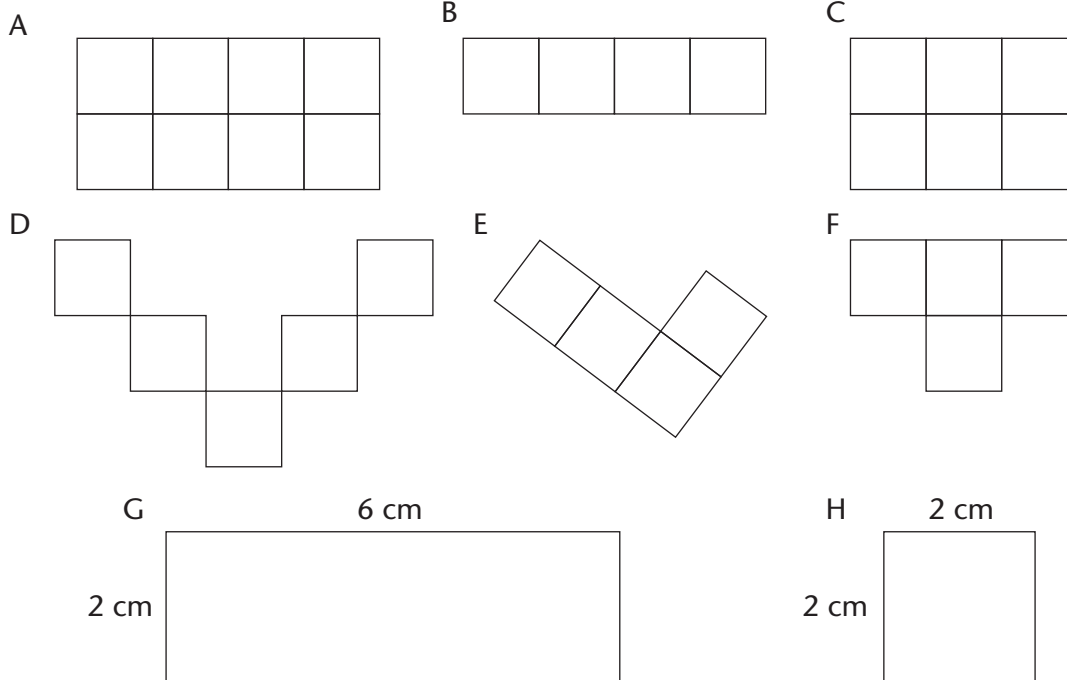

Figure	Perimeter	Area	Number of $1\text{ cm} \times 1\text{ cm}$ squares
A			
B			
C			
D			

Figure	Perimeter	Area	Number of 1 cm × 1 cm squares
E			
F			
G			
H			

2. Consider the rectangle below on the right-hand side. It is formed by tessellating identical squares that are 1 cm by 1 cm each. The white part has squares that are hidden.

- Write down, without counting, the total number of squares that form this rectangle, including those that are hidden. Explain your reasoning.
- What is the area of the rectangle, including the white part?

To **tessellate** means to cover a surface with identical shapes in such a way that there are no gaps or overlaps. Another word for tessellating is **tiling**.

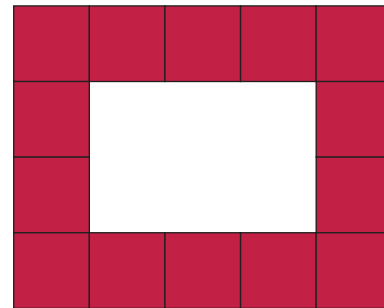

Both length (l) and breadth (b) are expressed in the same unit.

$$\begin{aligned} \text{Area of a rectangle} &= \text{length} \times \text{breadth} \\ &= l \times b \\ \text{Area of a square} &= l \times l \\ &= l^2 \end{aligned}$$

- Sipho and Theunis each paint a wall to earn some money during the school holidays. Sipho paints a wall 4 m high and 10 m long. Theunis's wall is 5 m high and 8 m long. Who should be paid more? Explain.
- What is the area of a square with a length of 12 mm?
- The area of a rectangle is 72 cm² and its length is 8 cm. What is its breadth?

14.2 Area and perimeter of composite figures

BREAKING UP FIGURES AND PUTTING THEM BACK TOGETHER AGAIN

- The diagram on the left on the following page shows the floor plan of a room. We can calculate the area of the room by dividing the floor into two rectangles, as shown in the diagram on the right on the following page.

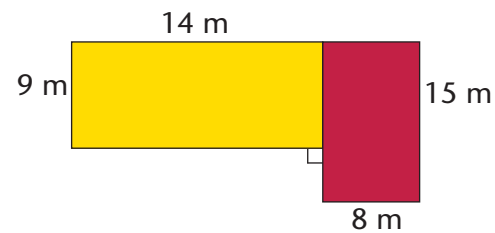
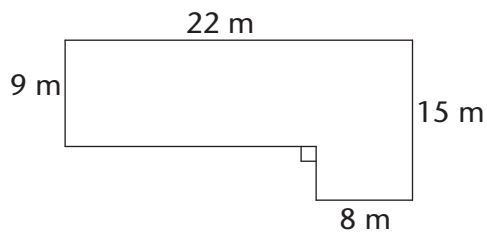

$$\begin{aligned}
 \text{Area of the room} &= \text{Area of yellow rectangle} + \text{Area of red rectangle} \\
 &= (l \times b) + (l \times b) \\
 &= (14 \times 9) + (15 \times 8) \\
 &= 126 + 120 \\
 &= 246 \text{ m}^2
 \end{aligned}$$

- (a) The yellow part of the room has a wooden floor and the red part is carpeted. What is the area of the wooden floor? What is the area of the carpeted floor?
- (b) Calculate the area of the room dividing the floor into two other shapes. Draw a sketch.

2. Calculate the area of the figures below.

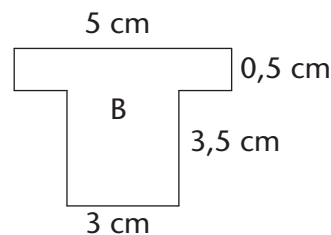
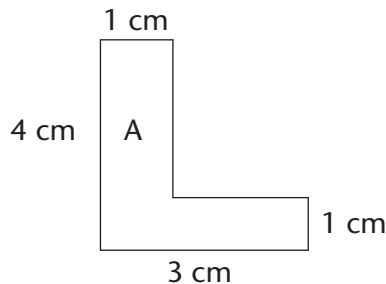

3. Which of the following rules can be used to calculate the perimeter (P) of a rectangle? Explain.

- Perimeter = $2 \times (l + b)$
- Perimeter = $l + b + l + b$
- Perimeter = $2l + 2b$
- Perimeter = $l + b$

l and b refer to the length and the breadth of a rectangle.

The following are equivalent expressions for perimeter:

$$P = 2l + 2b \text{ and } P = 2(l + b) \text{ and } P = l + b + l + b$$

4. Check with two classmates that the rule or rules you have chosen above are correct; then apply it to calculate the perimeter of figure A. Think carefully!
5. The perimeter of a rectangle is 28 cm and its breadth is 6 cm. What is its length?

14.3 Area and perimeter of circles

REVISING CONCEPTS FROM PREVIOUS GRADES

The perimeter of a circle is called the **circumference** of a circle. You will remember the following about circles from previous grades:

- The distance across the circle through its centre is called the **diameter** (d) of the circle.
- The distance from the centre of the circle to any point on the circumference is called the **radius** (r).
- The circumference (c) of a circle divided by its diameter is equal to the irrational value we call **pi** (π). To simplify calculations, we often use the approximate values:
 $\pi \approx 3,14$ or $\frac{22}{7}$.

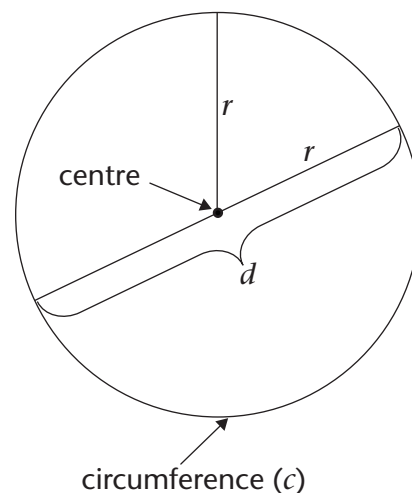

The following are important formulae to remember:

- $d = 2r$ and $r = \frac{1}{2}d$
- Circumference of a circle (c) = $2\pi r$
- Area of a circle (A) = πr^2

CIRCLE CALCULATIONS

In the following calculations, use $\pi = 3,14$ and round off your answers to two decimal places. If you take a square root, remember that length is always positive.

1. Calculate the perimeter and area of the following circles:
 - (a) A circle with a radius of 5 m
 - (b) A circle with a diameter of 18 mm
2. Calculate the radius of a circle with:
 - (a) a circumference of 53 cm
 - (b) a circumference of 206 mm
3. Work out the area of the following shapes:

A

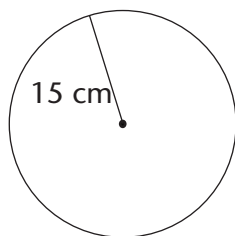

B

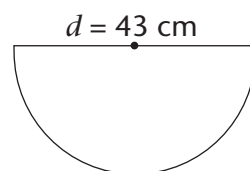

14.5 Area of other quadrilaterals

PARALLELOGRAMS

As shown below, a parallelogram can be made into a rectangle if a right-angled triangle from one side is cut off and moved to its other side.

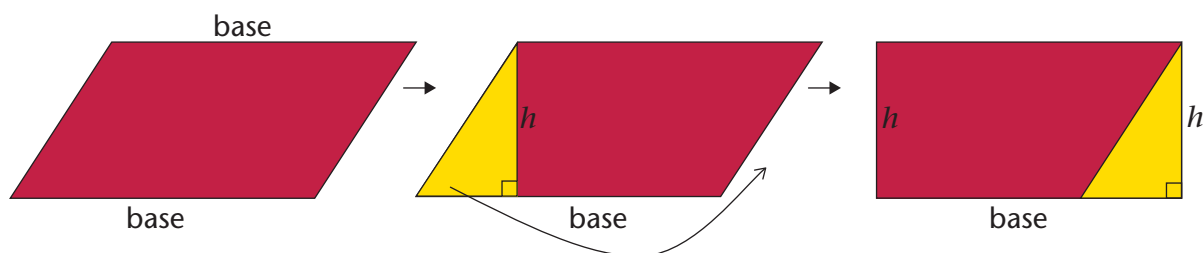

So we can find the area of a parallelogram using the formula for the area of a rectangle:

$$\begin{aligned} \text{Area of rectangle} &= l \times b \\ &= (\text{base of parallelogram}) \times (\text{perpendicular height of parallelogram}) \end{aligned}$$

Area of parallelogram = Area of rectangle

\therefore Area of parallelogram = base \times perp. height

We can use any side of the parallelogram as the base, but we must use the perpendicular height on the side we have chosen.

- Copy the parallelogram above.
 - Using the shorter side as the base of the parallelogram, follow the steps above to derive the formula for the area of a parallelogram.
- Work out the area of the following parallelograms using the formula:

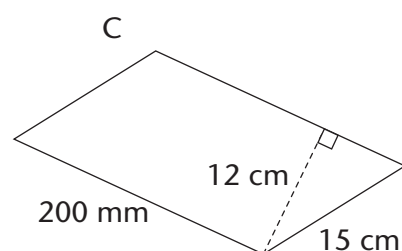
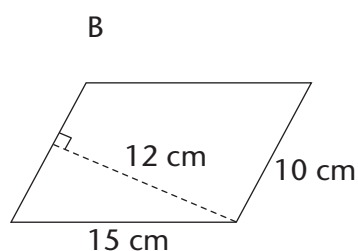
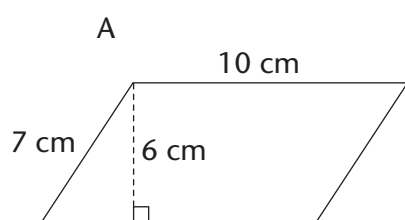

- Work out the area of the parallelograms. Use the Pythagoras' Theorem to calculate the unknown sides you need. Remember to use the pre-rounded value for height and then round the final answer to two decimal places where necessary.

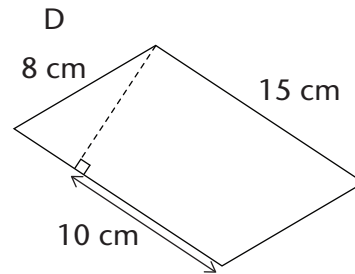
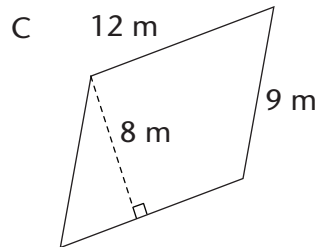
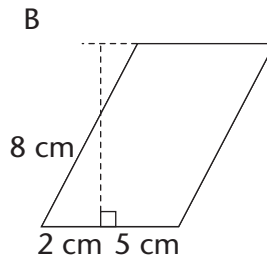
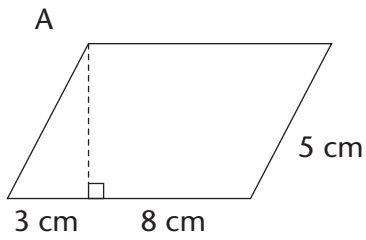

RHOMBI

A rhombus is a parallelogram with all its sides equal.

In the same way we derived the formula for the area of a parallelogram, we can show the following:

■ Area of a rhombus = length \times perp. height

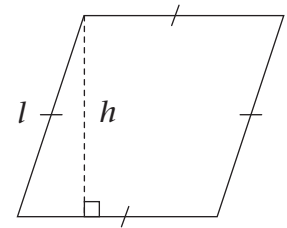

1. Show how to derive the formula for the area of a rhombus.
2. Calculate the areas of the following rhombi. Round off answers to two decimal places where necessary.

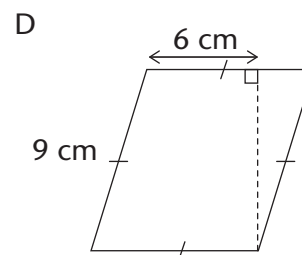
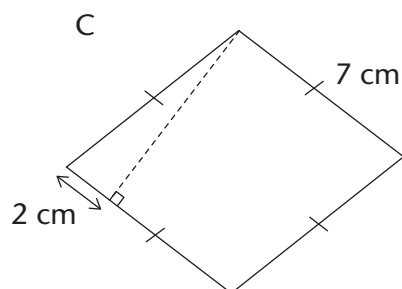
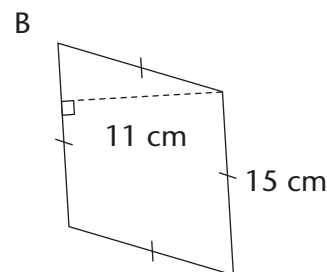
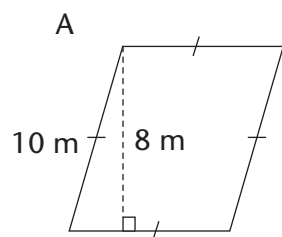

KITES

To calculate the area of a kite, you use one of its properties, namely that the diagonals of a kite are perpendicular.

Area of kite DEFG = Area of $\triangle DEG$ + Area of $\triangle EFG$

$$\begin{aligned} &= \frac{1}{2}(b \times h) + \frac{1}{2}(b \times h) \\ &= \frac{1}{2}(EG \times OD) + \frac{1}{2}(EG \times OF) \\ &= \frac{1}{2}EG(OD + OF) \\ &= \frac{1}{2}EG \times DF \end{aligned}$$

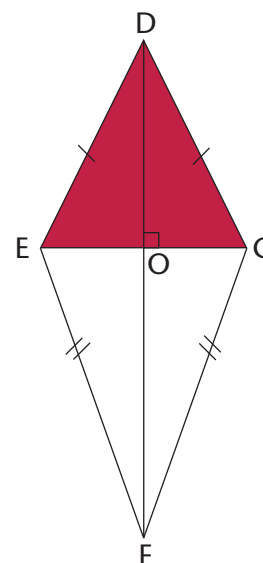

Notice that EG and DF are the diagonals of the kite.

$$\therefore \text{Area of a kite} = \frac{1}{2}(\text{diagonal}_1 \times \text{diagonal}_2)$$

- Calculate the area of kites with the following diagonals. Give your answers in m^2 .
 - 150 mm and 200 mm
 - 25 cm and 40 cm
- Calculate the area of the kite.

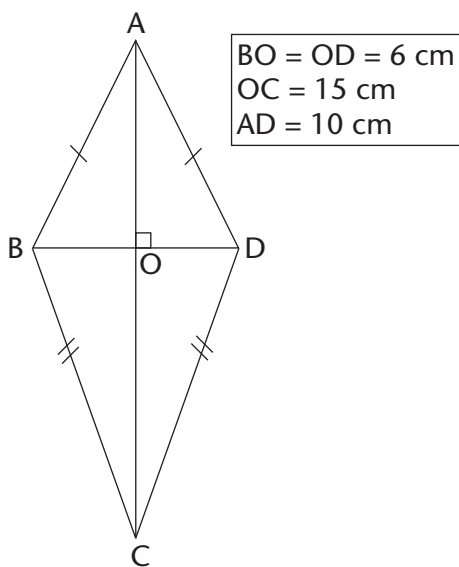

TRAPEZIUMS

A trapezium has two parallel sides. If we tessellate (tile) two trapeziums, as shown in the diagram on the following page, we form a parallelogram. (The yellow trapezium is the same size as the blue one. The base of the parallelogram is equal to the sum of the parallel sides of the trapezium.)

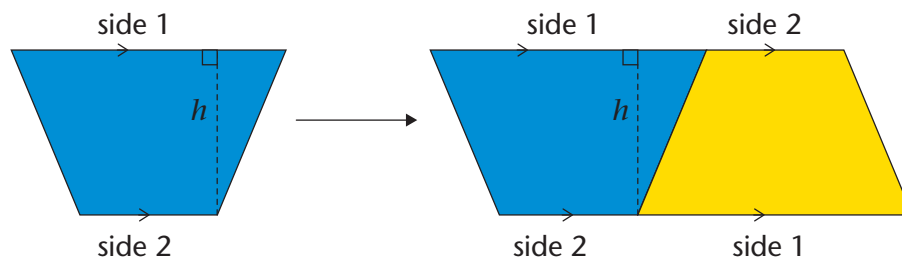

We can use the formula for the area of a parallelogram to work out the formula for the area of a trapezium as follows:

$$\begin{aligned} \text{Area of parallelogram} &= \text{base} \times \text{height} \\ &= (\text{side 1} + \text{side 2}) \times \text{height} \end{aligned}$$

$$\begin{aligned} \text{Area of trapezium} &= \frac{1}{2} \text{ area of parallelogram} \\ &= \frac{1}{2} (\text{side 1} + \text{side 2}) \times \text{height} \end{aligned}$$

∴ Area of a trapezium = $\frac{1}{2}$ (sum of parallel sides) × perp. height

Calculate the area of the following trapeziums:

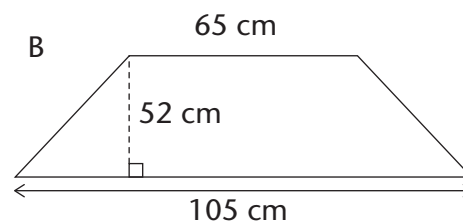
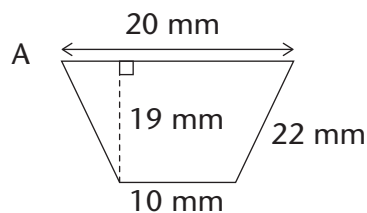

AREAS OF COMPOSITE SHAPES

Calculate the areas of the following 2D shapes. Round off your answers to two decimal places where necessary.

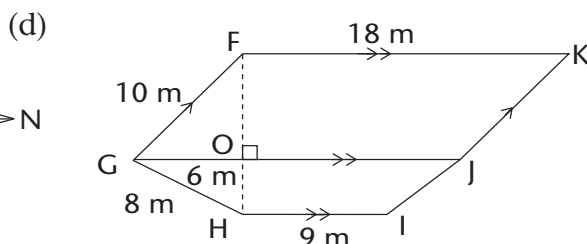
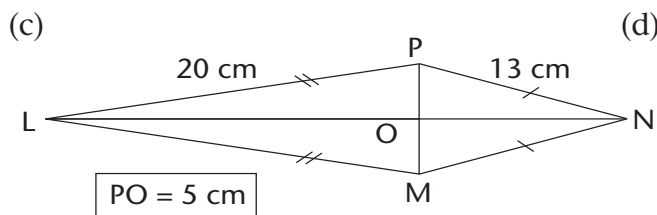
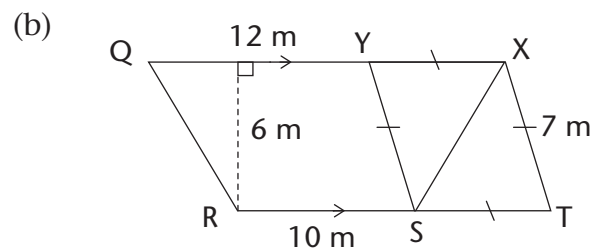
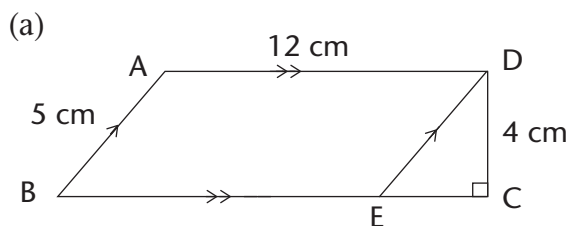

14.6 Doubling dimensions of a 2D shape

Remember that a 2D shape has two dimensions, namely length and breadth. You have used length and breadth in different forms, to work out the perimeters and areas of shapes, for example:

- length and breadth for rectangles and squares
- bases and perpendicular heights for triangles, rhombi and parallelograms
- two diagonals for kites.

But how does doubling one or both of the dimensions of a figure affect the figure's perimeter and area?

"Doubling" means to multiply by 2.



The four sets of figures on the next page are drawn on a grid of squares. Each row shows an original figure; the figure with one of its dimensions doubled, and the figure with both of its dimensions doubled. Each square has a side of one unit.

1. Work out the perimeter and area of each shape. Round off your answers to two decimal places where necessary.
2. Which figure in each set is congruent to the original figure?
3. Copy the table below and fill in the perimeter (P) and area (A) of each figure:

Figure	Original figure	Figure with both dimensions doubled
A	$P =$ $A =$	$P =$ $A =$
B	$P =$ $A =$	$P =$ $A =$
C	$P =$ $A =$	$P =$ $A =$
D	$P =$ $A =$	$P =$ $A =$

4. Look at the completed table. What patterns do you notice? Choose one:
 - When both dimensions of a shape are doubled, its **perimeter is doubled** and its **area is doubled**.
 - When both dimensions of a shape are doubled, its **perimeter is doubled** and its area is **four times bigger**.

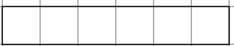
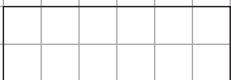
Original figure	One dimension doubled	Both dimensions doubled
-----------------	-----------------------	-------------------------

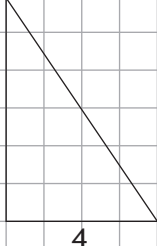
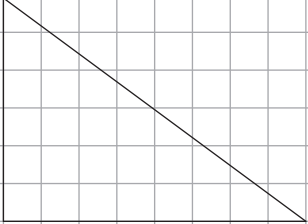
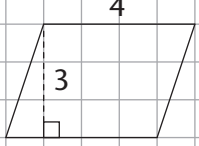
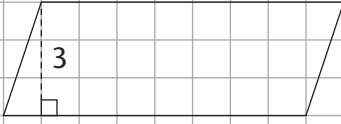
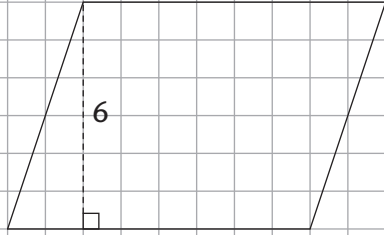
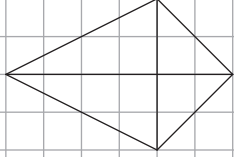
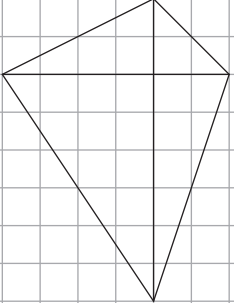
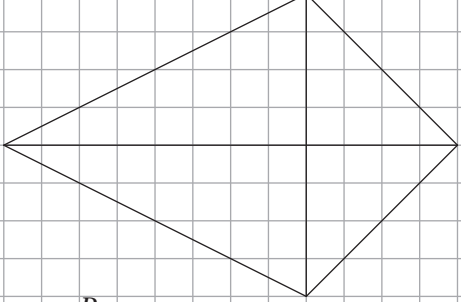
<p>A</p>  <p>$P =$ $A =$</p>	<p>6</p>  <p>$P =$ $A =$</p>	<p>6</p>  <p>$P =$ $A =$</p>
<p>B</p>  <p>$P =$ $A =$</p>	<p>6</p>  <p>$P =$ $A =$</p>	<p>6</p>  <p>$P =$ $A =$</p>
<p>C</p>  <p>$P =$ $A =$</p>	<p>8</p>  <p>$P =$ $A =$</p>	<p>8</p>  <p>$P =$ $A =$</p>
<p>Diagonal 1 = 4 Diagonal 2 = 6</p>	<p>Diagonal 1 = 8 Diagonal 2 = 6</p>	<p>Diagonal 1 = 8 Diagonal 2 = 12</p>
<p>D</p>  <p>$P =$ $A =$</p>	 <p>$P =$ $A =$</p>	 <p>$P =$ $A =$</p>

WORKSHEET

1. Write down the formulae for the following:

Perimeter of a square	
Perimeter of a rectangle	
Area of a square	
Area of a rectangle	
Area of a triangle	
Area of a rhombus	
Area of a kite	
Area of a parallelogram	
Area of a trapezium	
Diameter of a circle	
Circumference of a circle	
Area of a circle	

2. (a) Calculate the perimeter of the square and the area of the shaded parts of the square:

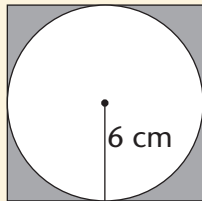

(b) Calculate the area of the kite:

