



**GAUTENG PROVINCE**  
EDUCATION  
REPUBLIC OF SOUTH AFRICA

**GAUTENG DEPARTMENT OF EDUCATION  
PROVINCIAL ASSESSMENT TASK  
NOVEMBER 2020**

**GRADE 3**

**ENGLISH FIRST ADDITIONAL  
LANGUAGE**

NAME OF LEARNER: \_\_\_\_\_

GRADE 3: \_\_\_\_\_

MARKS: 70

TIME: 30 minutes per day over a period of 5 days.

11 pages

## ACTIVITY 4: READING COMPREHENSION

Written activity

Answers literal questions about a story or non-fiction text.

Suggested time frame: Use 30 minutes.

Learner instruction:

- Read the story and answer questions 1 - 5.



Sometimes adults and kids need to wear masks to protect other people from getting sick. This might be something new for me. Masks might feel kind of uncomfortable at first, but I will get used to them.

Even when I wear a mask, it is important to be 1 meter away from other people. It is still okay to touch and hug my family.

I usually don't need to wear a mask in my home or my yard. If I go to a store or an appointment, I need to wear a mask. If I go somewhere with my family and there are other people around, I should wear a mask. A mask can protect other people if I cough or sneeze. It will also protect me from others. It is important to wash my hands with water and soap or to use a hand sanitiser.

Doctors are working very hard to find ways to make Covid-19 go away. Once it is gone, I will not need to wear a mask anymore. Wearing a mask is different, but it will be okay.

[Adapted from Autism Little Learners]

4.1 Circle the letter next to the correct answer.

What is a suitable title (name) for the story?

- A Wearing a hat.
- B Wearing a mask.
- C Wearing a shoe.
- D Wearing a jersey.

(1)

4.2 Place a cross (X) in the block next to the correct answer.

Why is it important to wear a mask when you go to the store or for an appointment?

To look very pretty when I go to the store.	
To scare my friends.	
To protect myself and other people from getting sick.	

(1)

4.3 Read the sentences and put a tick in the box for a correct sentence and a cross for the incorrect sentence.

	Correct √	Incorrect x
4.3.1 It is important to wash my hands or use a hand sanitizer.		
4.3.2 A mask cannot protect other people if I sneeze or cough.		

(2)

4.4 How will you feel when Covid-19 goes away? Name two things you will do.

---

---

---

---

(3)  
[7]

EXEMPLAR

ACTIVITY 5: PHONICS

Written activity

- Recognises and uses some suffixes.
- Recognises the first sound (onset) and the last syllable (rime).

Suggested time frame: 30 minutes

5.1 Look at the following words and circle the suffix in each word.

5.1.1 quickly

(1)

5.1.2 jumping

(1)

5.1.3 walked

(1)



5.1.4 reaches



(1)

[4]

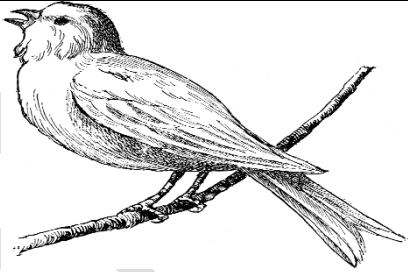
5.2 Choose the sound to write the correct word for the picture.

-ird, str-, ph-, -eaf, -tch, -nch

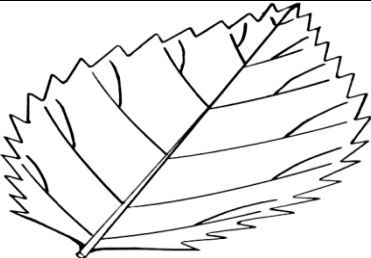
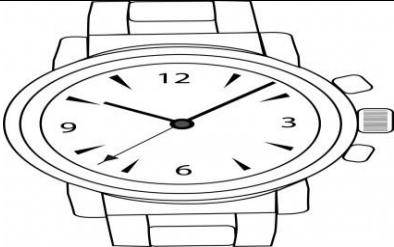
		
<p>5.2.1 _____</p>	<p>5.2.2 _____</p>	<p>5.2.3 _____</p>

		
<p>5.2.4 _____</p>	<p>5.2.5 _____</p>	<p>5.2.6 _____</p>

(6 x 1) (6)

P.T.O.

5.3

Learner instructions:

- Write the words as the teacher says them to you.

Spelling Test

- 5.3.1 \_\_\_\_\_ (1)
  - 5.3.2 \_\_\_\_\_ (1)
  - 5.3.3 \_\_\_\_\_ (1)
  - 5.3.4 \_\_\_\_\_ (1)
  - 5.3.5 \_\_\_\_\_ (1)
  - 5.3.6 \_\_\_\_\_ (1)
  - 5.3.7 \_\_\_\_\_ (1)
  - 5.3.8 \_\_\_\_\_ (1)
  - 5.3.9 \_\_\_\_\_ (1)
  - 5.3.10 \_\_\_\_\_ (1)
- [10]

## ACTIVITY 6: GRAMMAR

## Written activity

Learners focus on grammar in use, and demonstrate an understanding of the use of tenses, punctuation and other language structures.

Suggested time frame: 15 minutes

6.1 Rewrite the sentences in the given tenses.

6.1.1 Present tense

Mary wrote a letter to her friend about Covid-19.

---

(1)

6.1.2 Future tense

It is important to wash my hands with water and soap.

---

(1)

6.1.3 Past tense

A mask protects other people when I cough.

---

(2)  
[4]

6.2 Rewrite the sentences using the correct punctuation marks.

6.2.1 doctors are working very hard to find ways to make Covid-19 go away.

\_\_\_\_\_ (1)

6.2.2 Thabo woke up got out of bed and brushed his teeth.

\_\_\_\_\_ (1)

6.2.3 He said Let's go to the cinema.

\_\_\_\_\_ (2)  
[4]

6.3 Rewrite each sentence below using the comparative or superlative adjectives.

6.3.1 The mask he is wearing is (big) than mine.

\_\_\_\_\_ (1)

6.3.2 She is the (pretty) girl I have ever seen.

\_\_\_\_\_ (1)

6.3.3 That building is (large) than the one next to it.

\_\_\_\_\_ (1)

6.3.4 That is the (small) umbrella that I ever owned.

\_\_\_\_\_ (1)  
[4]



6.4 Write the plural (many) of the underlined words.

6.4.1 The teacher may send them home. \_\_\_\_\_ (1)

6.4.2 Paula enjoys her reading class. \_\_\_\_\_ (1)

6.4.3 Sometimes adults and kids need to wear mask. \_\_\_\_\_ (1)  
[3]

6.5 Read the graph below and complete 6.5.1 - 6.5.3

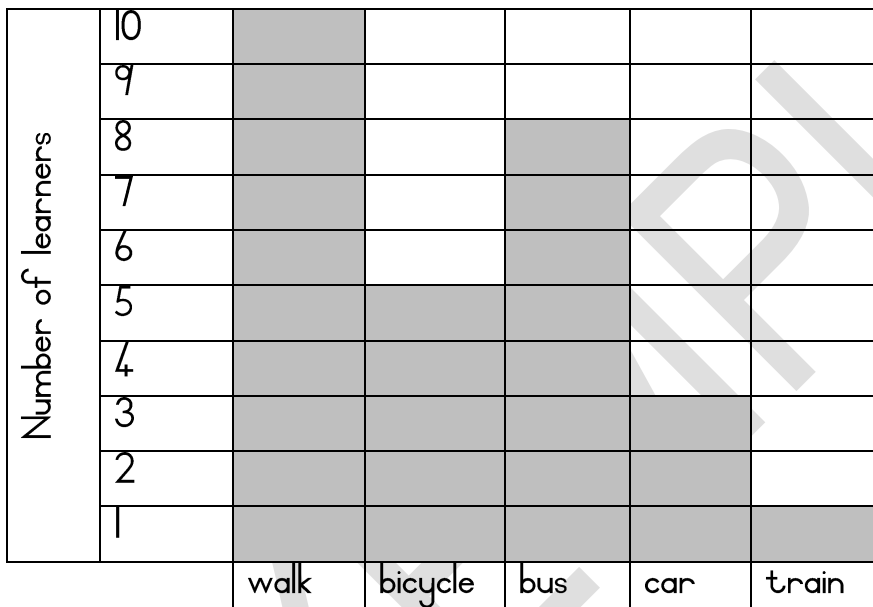

6.5.1 How many learners ride their bicycles to school? \_\_\_\_\_ (1)

6.5.2 How do most of the learners get to school? \_\_\_\_\_ (1)

6.5.3 How many learners are there altogether? \_\_\_\_\_ (1)  
[3]  
[18]

## ACTIVITY 7: WRITING

## Written Activity

Learners write a paragraph of 6 – 8 sentences on a familiar topic.

Suggested time frame: Use 30 minutes.

## Learner instructions:

- Read all the instructions carefully.

Write a paragraph of at least 8 sentences about 'Coronavirus'. Look at the pictures below to assist you in writing your paragraph.

Make sure that you use the correct punctuation, grammar and spelling.

Do not number your sentences.

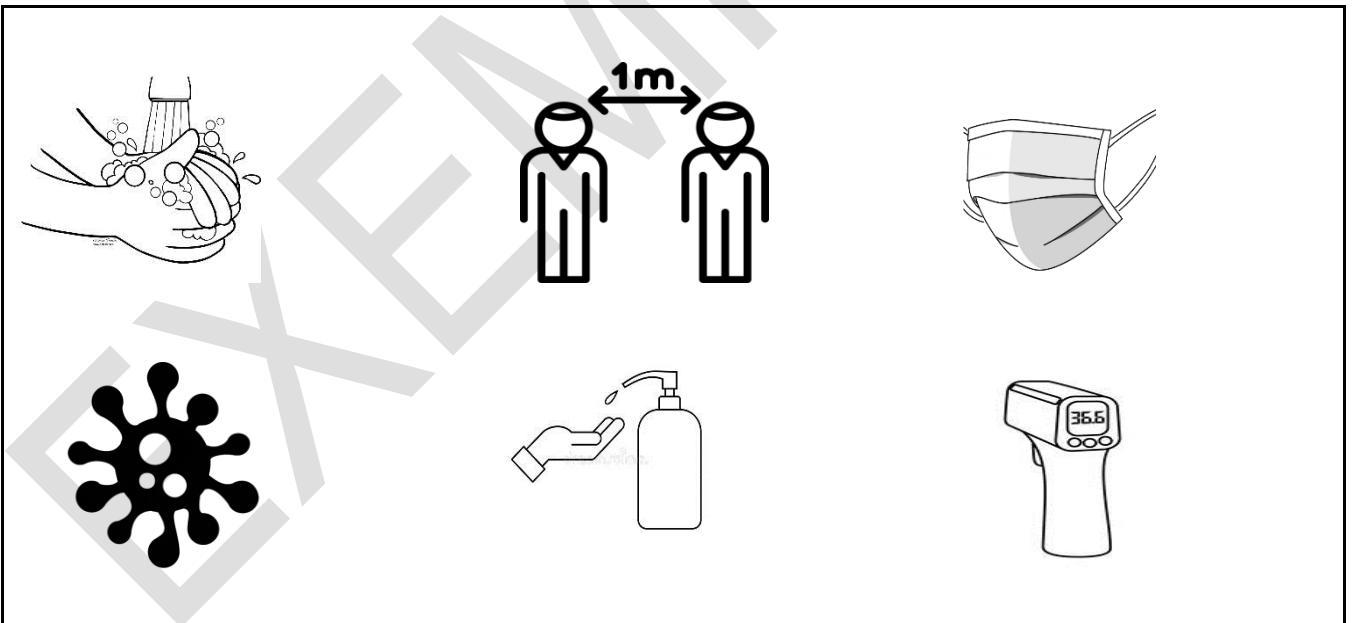

---

---

---

---

---

---

---

---

---

---

---

---

---

---

[[O]

TOTAL: 70

END