



**NATIONAL  
SENIOR CERTIFICATE**

**GRADE 12**

**SEPTEMBER 2022**

**CIVIL TECHNOLOGY: WOODWORKING**

**MARKS: 200**

**TIME: 3 hours**

---

This question paper consists of 20 pages, including 9 answer sheets.

---

**REQUIREMENTS:**

1. ANSWER BOOK
2. Drawing instruments
3. A non-programmable pocket calculator

**INSTRUCTIONS AND INFORMATION**

1. This question paper consists of SIX questions: TWO questions are generic and FOUR questions are subject specific.
2. Answer ALL the questions.
3. Answer each question as a whole. Do NOT separate subsections of questions.
4. Start the answer to EACH question on a NEW page.
5. Do NOT write in the margins of the ANSWER BOOK.
6. You may use sketches to illustrate your answers.
7. Write ALL calculations and answers in the ANSWER BOOK or on the attached ANSWER SHEETS.
8. Use the mark allocation as a guide to the length of your answers.
9. Make drawings and sketches in pencil, fully dimensioned and neatly finished off with descriptive titles and notes to conform to the *SANS/SABS Code of Practice for Building Drawings*.
10. For the purpose of this question paper, the size of a brick should be taken as 220 mm x 110 mm x 75 mm.
11. Use your own discretion where dimensions and/or details have been omitted.
12. Answer QUESTIONS 2.1, 3.3, 3.4, 3.5, 4.9, 5.5, 5.7, 6.3, 6.4, 6.7 and 6.8 on the attached ANSWER SHEETS using drawing instruments where necessary.
13. Write your NAME on every ANSWER SHEET and hand them in with your ANSWER BOOK, whether you have answered the question or not.
14. Due to electronic transfer, drawings in the question paper are NOT to scale.

**QUESTION 1: SAFETY AND MATERIALS (GENERIC)**

Start this question on a NEW page.

- 1.1 Define the term *accident*. (2)
- 1.2 Name the material that scaffolding is made from. (1)
- 1.3 Choose the correct answer from the words between the brackets that is related to scaffolding:
- 1.3.1 The safety factor that is used for scaffolding frames is (one / two / three). (1)
- 1.3.2 The minimum thickness of a wooden scaffold platform is (38 mm / 50 mm / 76 mm). (1)
- 1.3.3 The minimum height of a suspended scaffold is (900 mm / 1 200 mm / 1 500 mm). (1)
- 1.4 Give TWO reasons why scaffolding must be inspected before it can be used. (2 x 1) (2)
- 1.5 What is the maximum distance that a suspended scaffold may hang over the edge of the structure? (1)
- 1.6 What is the maximum height of a trestle scaffold? (1)
- 1.7 Answer the following questions with regard to ladders.
- 1.7.1 Why should only one person at a time use a ladder? (1)
- 1.7.2 What should the end of a ladder be marked with when it is transported? (1)
- 1.7.3 Name ONE material that ladders can be made from. (1)
- 1.7.4 Why should ladders be kept clean and free of oil and grease? (1)
- 1.8 Name TWO advantages of a water-based paint. (2 x 1) (2)
- 1.9 Name TWO advantages for the curing of concrete. (2 x 1) (2)
- 1.10 Name TWO methods that can be used to prevent the corrosion of metals. (2 x 1) (2)
- [20]**

**QUESTION 2: GRAPHICS, JOINING AND EQUIPMENT (GENERIC)**

Start this question on a NEW page.

- 2.1 FIGURE 2.1 on ANSWER SHEET A shows the outer lines of a structure which must be built on a site. Draw the site plan on scale 1 : 200 on ANSWER SHEET A so that the structure is in the middle of the site.

The site plan must comply with the following requirements.  
Use the points table on ANSWER SHEET A as reference.

- 2.1.1 Plot size is 30 m wide from east to west and 40 m long from south to north. (2)
- 2.1.2 Pavement of 2 m and the street of 6 m on the south side. (3)
- 2.1.3 Building boundaries are 2 m on the east, north and west sides and 4 m on the south side. (4)
- 2.1.4 3 m wide entrance to the site. (2)
- 2.1.5 Datum level in the north-west corner of the site. (2)

Draw in the sewer lay-out for the structure and show the following:

- 2.1.6 Water closet symbol at the abbreviation (1)
- 2.1.7 Sewer pipes (2)
- 2.1.8 Rodding eye with the abbreviation (2)
- 2.1.9 Inspection eye with the abbreviation (2)
- 2.1.10 Manhole with the abbreviation (2)

Indicate the following measurements:

- 2.1.11 Length and width of the site. (4)
- 2.1.12 South and west building boundaries. (2)
- 2.2 What is the advantage of the square shoulder bolt? (1)
- 2.3 Name parts **A** to **D** of the bolt in FIGURE 2.3. (4 x 1) (4)

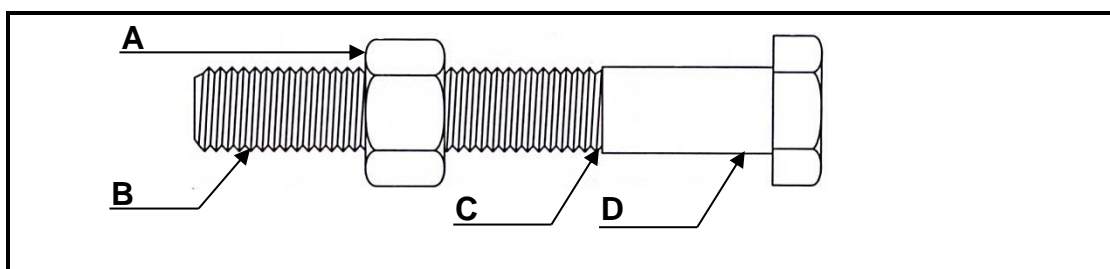

**FIGURE 2.3**

- 2.4 What is the purpose of the nylon insert of a hexagonal nut? (1)
- 2.5 What is the advantage of a wing nut? (1)
- 2.6 FIGURE 2.6 shows the dumpy level reading which is taken on the telescopic staff. Answer the following questions with regard to the reading.

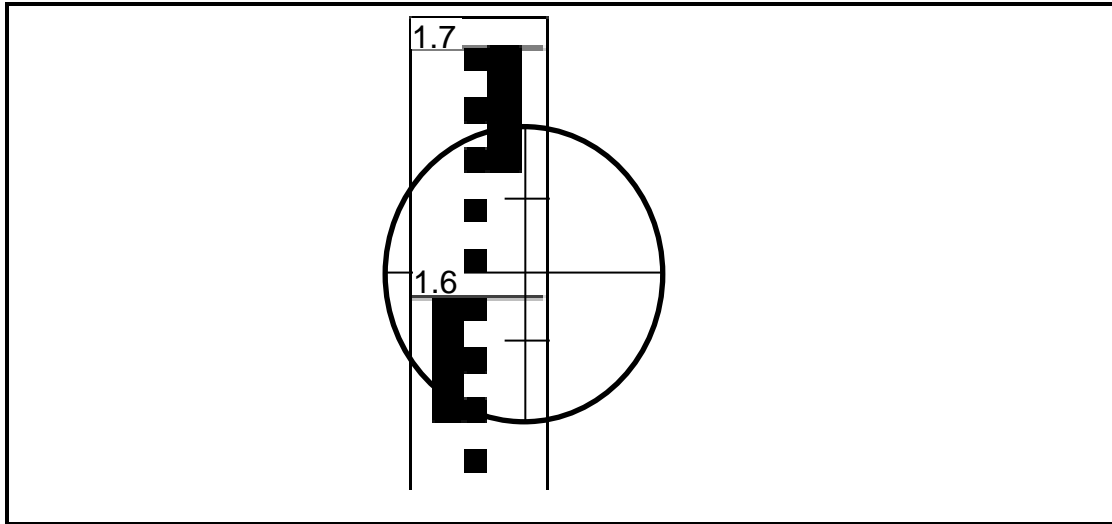

FIGURE 2.6

- 2.6.1 What is the height reading on the staff? (1)
  - 2.6.2 Determine the distance between the dumpy level and the staff. Show ALL calculations, formulae and units. (4)
- [40]

TOTAL SECTION A: 60

### QUESTION 3: CASEMENTS, CUPBOARDS, WALL-PANELLING AND QUANTITIES (SPECIFIC)

Start this question on a NEW page.

- 3.1 Give ONE word/term for each of the following descriptions by choosing a word/term from the list below. Write only the word/term next to the question numbers (3.1.1 to 3.1.4) in the ANSWER BOOK, for example 3.1.5 casement.

transom; 20 mm; skirting; 18 mm; stiles; shuttering boards;  
 mullion; 9 m<sup>2</sup>; 8,5 m<sup>2</sup>; 16 mm; frame; frame stiles; 7,5 m<sup>2</sup>;  
 cornice; 32 mm; glazing bars; 18 m<sup>2</sup>; 15 m<sup>2</sup>

- 3.1.1 The thickness of melamine used for cupboard doors (1)
- 3.1.2 To close the opening where the wall panel and the floor meet (1)
- 3.1.3 The area of the roof underlay for a lean-to roof of 2,5 m x 3 m (1)
- 3.1.4 The intermediate vertical member that separates two casements in a double casement (1)
- 3.2 FIGURE 3.2 below shows a vertical section through a certain part of a double casement window with a fanlight. Study the picture and answer the questions that follow.

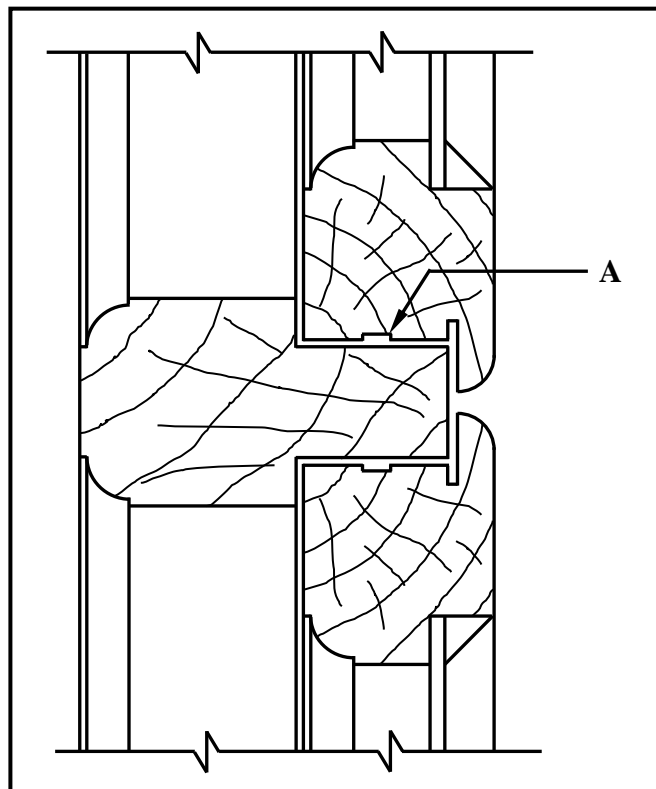

**FIGURE 3.2**

- 3.2.1 Name THREE timber parts of the casement and frame. (3)
- 3.2.2 Identify A. (1)

- 3.3 FIGURE 3.3 below shows the floor plan of a building with a gable roof. The external measurements are 8 000 mm x 4 000 mm.

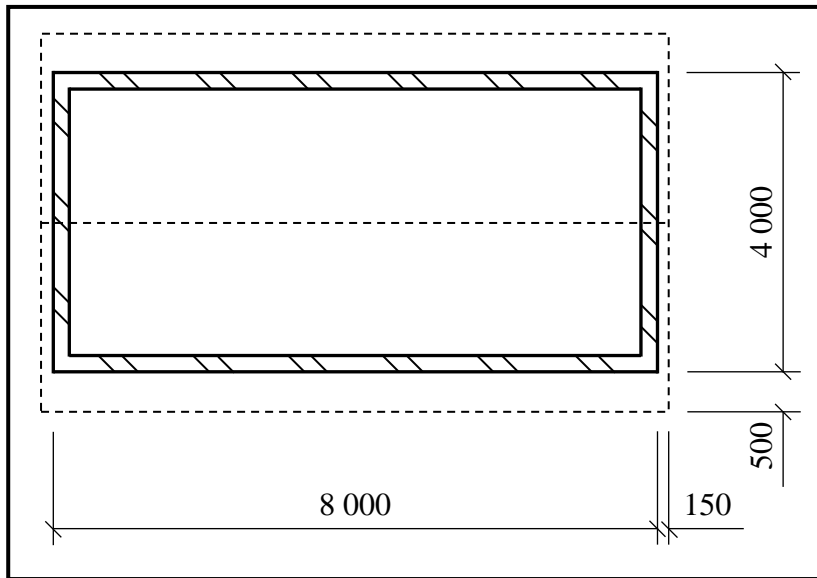

**FIGURE 3.3**

Use the following specifications:

- The walls are 220 mm thick
- Type of roof: South African (Howe)
- Corrugated roof sheeting is used as roof covering
- The pitch of the roof is 30°
- The true length of the rafter is 2 900 mm
- The length of one ridge plate is 1 800 mm
- The corrugated roof sheeting projects 50 mm past the rafter

Use the dimension paper on ANSWER SHEET 3.3 and calculate the quantities of the following materials needed for the roof:

- 3.3.1 Area of roof sheeting for the building (6)
- 3.3.2 Number of ridge plates (3)
- 3.4 Use ANSWER SHEET 3.4 and draw, in a good proportion, a neat sketch of a vertical section through the top part of a wall panel that ends halfway between the ceiling and the floor.
- Use the assessment criteria on the ANSWER SHEET as a guide. (5)
- 3.5 ANSWER SHEET 3.5 shows the front view of the framework of a built-in cupboard without the doors.

Use ANSWER SHEET 3.5 and complete, in good proportion, the given drawing.

Use the assessment criteria on the ANSWER SHEET as a guide. (8)

**[30]**

**QUESTION 4: ROOFS, CEILINGS, TOOLS AND EQUIPMENT, AND MATERIALS (SPECIFIC)**

Start this question on a NEW page.

4.1 FIGURE 4.1 below shows two woodworking machines. Study the pictures and answer the questions that follow.

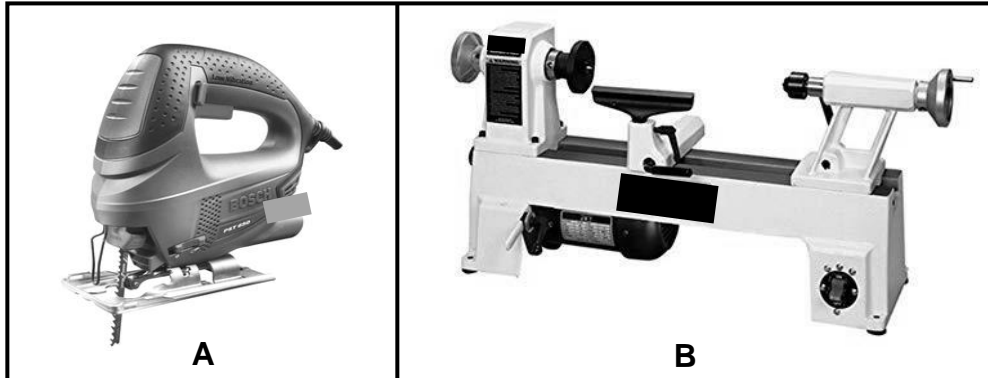

**FIGURE 4.1**

- 4.1.1 Identify **A** and **B**. (2)
- 4.1.2 Describe TWO aspects that must be considered when taking care of machine, **A** in terms of its blade. (2)
- 4.1.3 Describe TWO safety aspects that one would check after mounting the work piece, before switching on **B**. (2)
- 4.2 Describe ONE way in which a belt sander can be stored. (1)
- 4.3 State TWO properties that are tested in both mechanical and visual grading. (2)
- 4.4 Describe the first THREE steps that need to be considered when preparing timber before applying preservatives. (3)
- 4.5 Differentiate between a *conventional trap door* and a *hinged trap door* in a ceiling in terms of the way in which it opens. (2)
- 4.6 Name TWO parts of a conventional trapdoor. (2)
- 4.7 Give the correct measurements for the following members of a roof:
- King post
  - Brandering
- (2)
- 4.8 Differentiate between *hurricane clips* and *storm clips* regarding the specific roof members that they will secure. (2)
- 4.9 Use ANSWER SHEET 4.9 and draw to scale 1 : 20 a close-coupled roof truss with a pitch of 30°, a span of 3 metres and an eaves overhang of 400 mm. The truss rests on two supporting walls.

Use the assessment criteria on the ANSWER SHEET as a guide.

(20)

**[40]**



**QUESTION 5: CENTRING, FORMWORK, SHORING AND GRAPHICS AS MEANS OF COMMUNICATION (SPECIFIC)**

Start this question on a NEW page.

- 5.1 Name the type of lagging that you would use for the centres when you have to build the following:
  - 5.1.1 Rough arch (1)
  - 5.1.2 Gauged arch (1)
- 5.2 Draw in your ANSWER BOOK, in good proportion, a centre for a semi-circular arch that will be built over a door opening. Label any TWO parts on the drawing. (6)
- 5.3 Name the material that can be used for the sides of the formwork for a square column, which saves time because no surface finishing is needed and no absorption of moisture from the concrete takes place. (1)
- 5.4 What will you apply to the formwork before the casting of concrete to prevent the concrete from clinging to the inside of the formwork when striking takes place? (1)
- 5.5 FIGURE 5.5 on ANSWER SHEET 5.5 shows the incomplete formwork of a concrete beam. Use ANSWER SHEET 5.5 and draw, in good proportion, ONLY the left half of the vertical section of the formwork for the concrete beam. (8)  
Use the assessment criteria on the ANSWER SHEET as a guide.
- 5.6 FIGURE 5.6 shows a line diagram of a double-flying shore between two walls. Label A to F. (6)

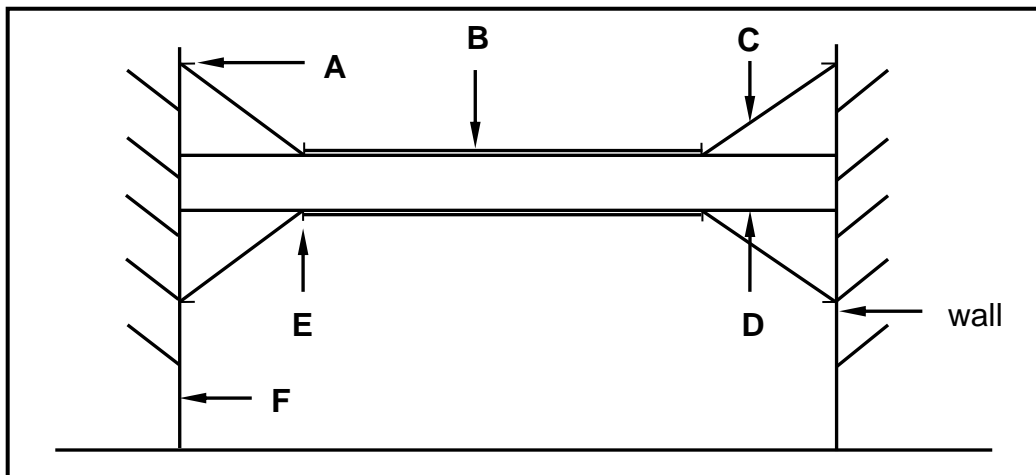

**FIGURE 5.6**

- 5.7 Use ANSWER SHEET 5.7 and draw to scale 1 : 2 an assembled isometric view of a stub haunched mortise and tenon joint to join a stile and a top rail. The timber used is 60 mm wide and 20 mm thick. (6)

Start the drawing from the given corner on ANSWER SHEET 5.7. Do NOT show hidden details. Use the assessment criteria on the ANSWER SHEET as a guide.

(6)  
**[30]**

**QUESTION 6: SUSPENDED FLOORS, STAIRCASES, IRONMONGERY, DOORS AND JOINING (SPECIFIC)**

Start this question on a NEW page.

6.1 Various options are given as possible answers to the following questions. Choose the answer and write only the letter (A–D) next to the question numbers (6.1.1 to 6.1.5) in the ANSWER BOOK, for example 6.1.6 C.

6.1.1 Screws are generally used to secure a hinge onto the frame and ... of a door.

- A top rail
- B bottom rail
- C muntin
- D stile (1)

6.1.2 A wall plate can be secured to a wall with ...

- A oval wire nails.
- B self-tapping hexagonal screws.
- C truss hangers.
- D a double strand of 2,5 mm diameter galvanised wire. (1)

6.1.3 IBR sheeting are secured to ...

- A purlins with roofing nails.
- B rafters with roofing nails.
- C rafters with gang nails.
- D purlins with clout nails. (1)

6.1.4 The haunch of a haunched mortise and tenon joint ...

- A adds strength and prevents the rail from twisting.
- B decreases the bonding area.
- C gives a more appealing look to the joint.
- D is half the thickness of the rail. (1)

6.1.5 Window panes are fixed onto casement members with ...

- A casement stays.
- B glazing beads.
- C rails.
- D casement fasteners. (1)

6.2 FIGURE 6.2 below shows an assembled view of a timber joint.

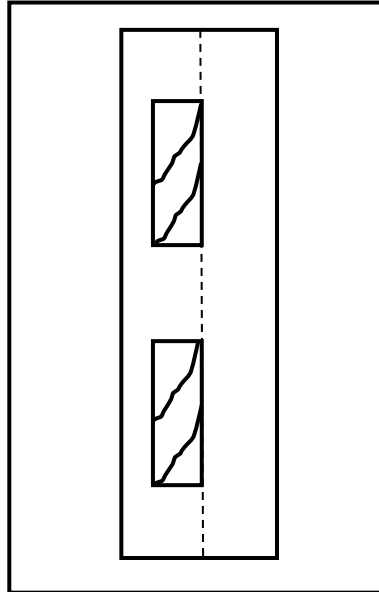

FIGURE 6.2

- 6.2.1 Identify the type of joint. (1)
- 6.2.2 Name ONE type of door where you will use this joint. (1)
- 6.3 Draw in your ANSWER BOOK, in good proportion, two horizontal sectional views to show the difference between a *door frame* and a *jamb lining* fixed to a wall. Print the title below ONE of these drawings. (6)
- 6.4 Draw in your ANSWER BOOK, in good proportion, a horizontal cross section through a muntin and raised panels of a three-panel door. (6)
- 6.5 Name TWO places where a straight cupboard lock can be used. (2)
- 6.6 Name a lock that is mounted onto the internal surface of doors to provide extra security. (1)
- 6.7 FIGURE 6.7 on ANSWER SHEET 6.7 shows the top view of the walls around a staircase. Use ANSWER SHEET 6.7 and draw, in good proportion, the top view of a flight of stairs with an open well and a half-landing within the given walls. (6)

Use the assessment criteria on the ANSWER SHEET as a guide. (6)

6.8 FIGURE 6.8 on ANSWER SHEET 6.8 shows the external wall of a building to accommodate a suspended timber floor. Draw, in good proportion, the suspended floor on ANSWER SHEET 6.8.

Use the assessment criteria on the ANSWER SHEET as a guide. (12)

[40]

**TOTAL: 200**

<b>ANSWER SHEET    A</b>	<b>CIVIL TECHNOLOGY GENERIC</b>	<b>NAME:</b> _____
--------------------------	-------------------------------------	--------------------

2.1 FIGURE 2.1 on ANSWERSHEET A shows the outer lines of a structure of a site plan. Draw the site plan on a scale 1 : 200 on the ANSWER SHEET A, so that the structure is in the middle of the site. (28)

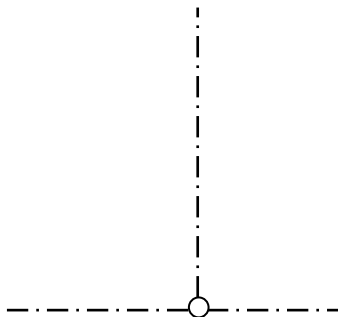
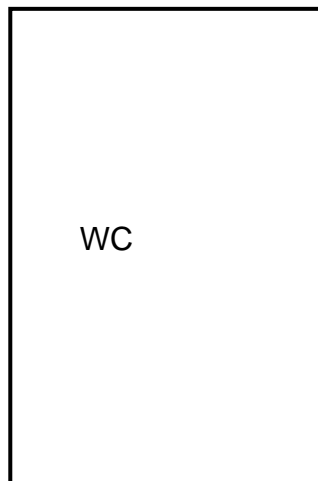

Plot size	2	
Sidewalk + street	3	
Building boundary/line	4	
Entrance	2	
Exit point	2	
Water closet pan	1	
Main sewage connection point	2	
Inspection eye + abbreviation	2	
Rodding eye + abbreviation	2	
Manhole + abbreviation	2	
Measurements	6	
<b>TOTAAL:</b>	<b>28</b>	

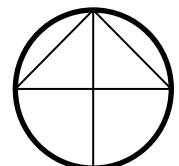



<b>ANSWER SHEET C</b>	<b>CIVIL TECHNOLOGY GENERIC</b>	<b>NAME:</b> _____
-----------------------	-------------------------------------	--------------------

**ANSWER SHEET 3.4**

<b>ASSESSMENT CRITERIA</b>	<b>MARK</b>	<b>CANDIDATE'S MARK</b>
Wall	1	
Capping	1	
Rough ground	1	
Tongue and groove board	1	
Correctness of drawing	1	
<b>TOTAL:</b>	<b>5</b>	

<b>ANSWER SHEET D</b>	<b>CIVIL TECHNOLOGY GENERIC</b>	<b>NAME:</b> _____
-----------------------	-------------------------------------	--------------------

**ANSWER SHEET 3.5**

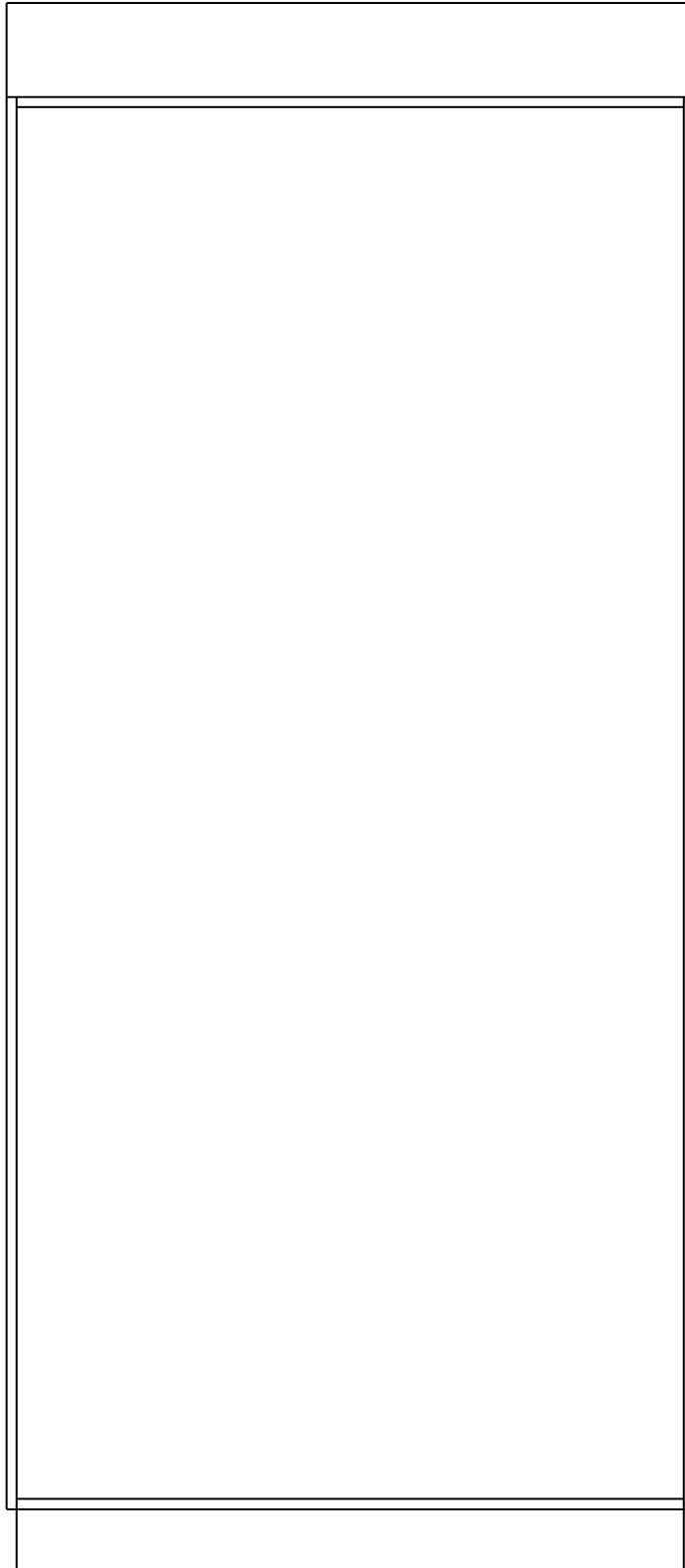

**FIGURE 3.5**

<b>ASSESSMENT CRITERIA</b>	<b>MARK</b>	<b>CM</b>
Top shelf (full width)	1	
Intermediate side in middle	1	
Hanging space on left side	1	
Oval hanging rail	1	
FOUR shelves	2	
TWO drawer units below shelving	1	
Correctness of drawing	1	
<b>TOTAL:</b>	<b>8</b>	

<b>ANSWER SHEET</b>	<b>E</b>	<b>CIVIL TECHNOLOGY GENERIC</b>	<b>NAME:</b> _____
---------------------	----------	-------------------------------------	--------------------

**ANSWER SHEET 4.9**

<b>ASSESSMENT CRITERIA</b>	<b>MARK</b>	<b>CM</b>
Walls drawn correctly	2	
Wall plates drawn correctly	2	
Tie beam drawn correctly	2	
Rafters drawn correctly	2	
Ridge beam drawn correctly	2	
Overhang drawn correctly	2	
Labels (any TWO)	2	
Span width	1	
Dimensions of members (any TWO)	2	
Application of scale: ONE or TWO incorrect = 3 THREE or FOUR incorrect = 2 More than FIVE incorrect = 1 NO measurement correct = 0	3	
<b>TOTAL:</b>	<b>20</b>	



<b>ANSWER SHEET</b> <b>F</b>	<b>CIVIL TECHNOLOGY GENERIC</b>	<b>NAME:</b> _____
------------------------------	-------------------------------------	--------------------

**ANSWER SHEET 5.5**

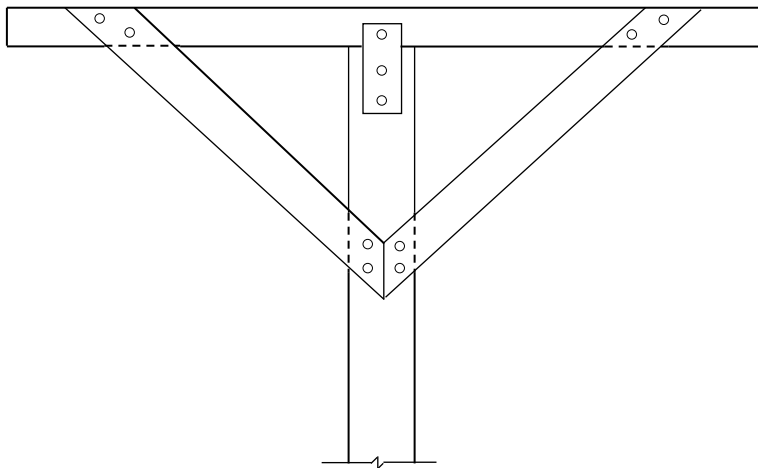

**FIGURE 5.5**

<b>ASSESSMENT CRITERIA</b>	<b>MARK</b>	<b>CANDIDATE'S MARK</b>
Shuttering board side	1	
Cleat	1	
Kicker/Fixing plate	1	
Wedge	1	
Stay/Strut	1	
Any TWO labels	2	
Correctness of drawing	1	
<b>TOTAL:</b>	<b>8</b>	

<b>ANSWER SHEET</b> <b>G</b>	<b>CIVIL TECHNOLOGY GENERIC</b>	<b>NAME:</b> _____
------------------------------	-------------------------------------	--------------------

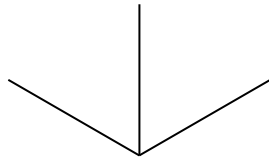
**ANSWER SHEET 5.7**

<b>ASSESSMENT CRITERIA</b>	<b>MARK</b>	<b>CANDIDATE'S MARK</b>
Stile	1	
Top rail	1	
Haunch	3	
Application of scale	1	
<b>TOTAL:</b>	<b>6</b>	

<b>ANSWER SHEET H</b>	<b>CIVIL TECHNOLOGY GENERIC</b>	<b>NAME:</b> _____

**ANSWER SHEET 6.7**

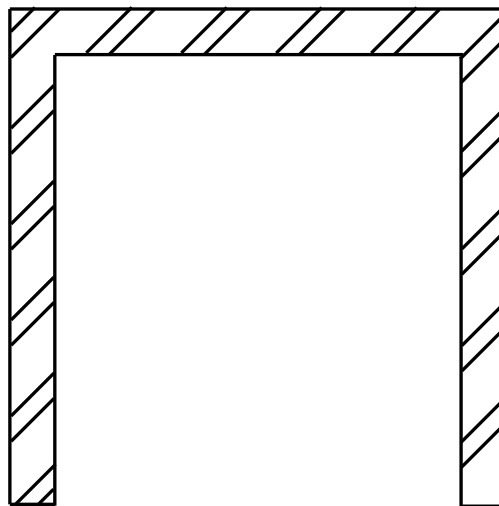
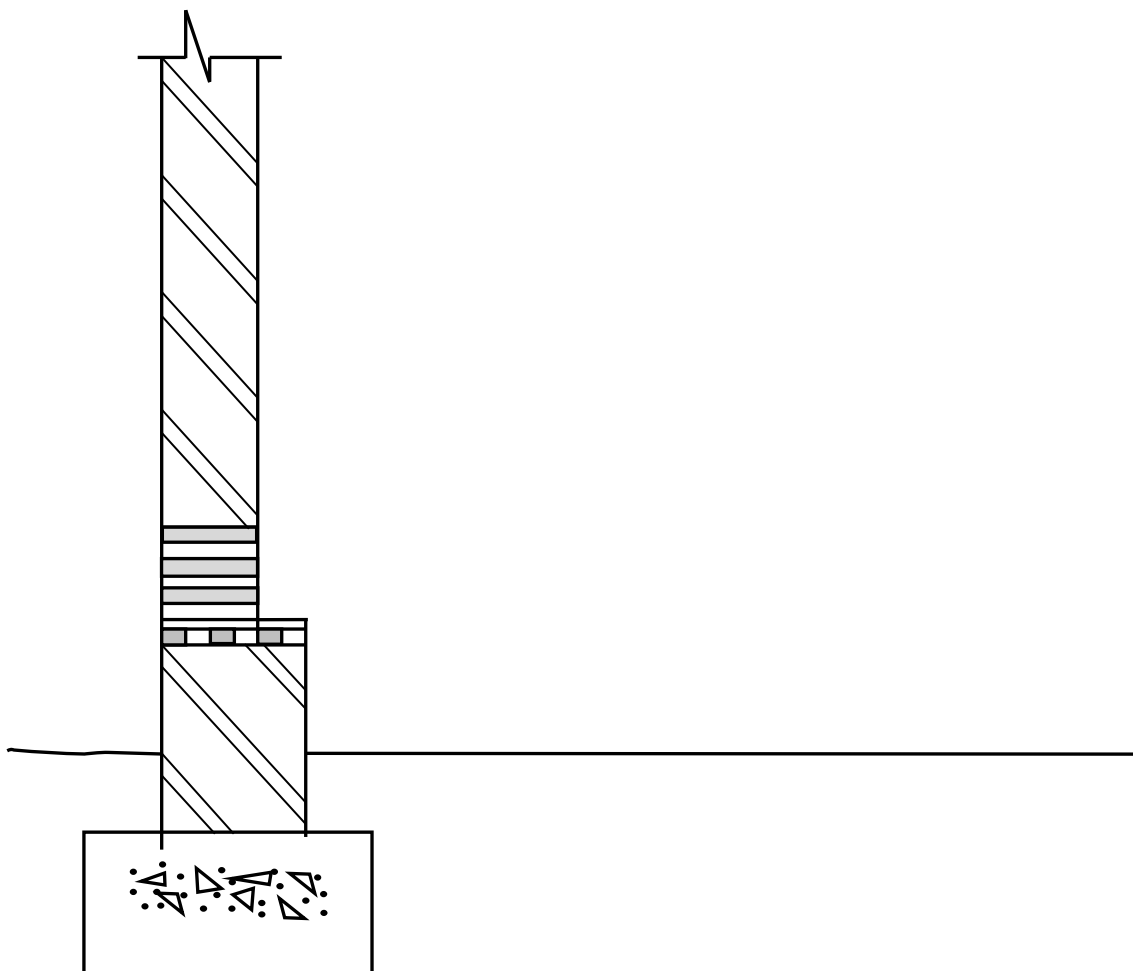

**FIGURE 6.7**

<b>ASSESSMENT CRITERIA</b>	<b>MARK</b>	<b>CANDIDATE'S MARK</b>
Treads on each flight of stairs	2	
Half-landing	1	
Newel post	1	
Open well	1	
Correctness of drawing	1	
<b>TOTAL:</b>	<b>6</b>	

<b>ANSWER SHEET</b>	<b>CIVIL TECHNOLOGY GENERIC</b>	NAME: _____
---------------------	-------------------------------------	-------------

**ANSWER SHEET 6.8**



**FIGURE 6.8**

ASSESSMENT CRITERIA	MARK	CANDIDATE'S MARK
Bearer	1	
Joists	2	
Wall plate	1	
Tongue and groove floorboard	1	
Skirting	1	
Quadrant	1	
Hatching	1	
Labels for: Ant guard	1	
Air brick	1	
DPC	1	
Correctness of drawing	1	
<b>TOTAL:</b>	<b>12</b>	