



Province of the  
**EASTERN CAPE**  
EDUCATION

---



**NATIONAL  
SENIOR CERTIFICATE**

**GRADE 12**

**SEPTEMBER 2022**

**ELECTRICAL TECHNOLOGY: ELECTRONICS**

**MARKS: 200**

**TIME: 3 hours**

---

This question paper consists of 18 pages, including a 2-page formula sheet.

---

**INSTRUCTIONS AND INFORMATION**

1. This question paper consists of SIX questions.
2. Sketches and diagrams must be large, neat and FULLY LABELLED.
3. Show ALL calculations and round off answers to TWO decimal places.
4. Number the answers correctly according to the numbering system used in this question paper.
5. You may use a non-programmable calculator.
6. Show the units for ALL answers of calculations.
7. A formula sheet is provided at the end of this question paper.
8. Write neatly and legibly.

**QUESTION 1: MULTIPLE-CHOICE QUESTIONS**

Various options are given as possible answers to the following questions. Choose the answer and write only the letter (A–D) next to the question numbers (1.1 to 1.15) in the ANSWER BOOK, for example 1.16 D.

- 1.1 The purpose of the Occupational Health and Safety Act is to ...
- A provide for the health and safety of persons at work.
  - B provide for the health and safety of persons at home.
  - C prevent wear and tear on machinery.
  - D prevent workers from using machinery. (1)
- 1.2 In a parallel RLC circuit ...
- A  $I_L = I_C = I_R$ .
  - B  $X_L = X_C = R$ .
  - C  $V_L = V_C = V_R$ .
  - D  $V_T = I_T = Z_T$ . (1)
- 1.3 The capacitance of a capacitor with a capacitive reactance of 31,83  $\Omega$  when connected to a 110 V/50 Hz supply is:
- A 10  $\mu\text{F}$
  - B 100  $\mu\text{F}$
  - C 100 nF
  - D 10 nF (1)
- 1.4 The bandwidth of a series resonant circuit is ... affected by its quality factor.
- A not
  - B indirectly
  - C directly
  - D negatively (1)
- 1.5 The FET relies on the creation of an ...
- A electric field within its body to control magnetic fields.
  - B electric field within its body to control current flow.
  - C quality factor.
  - D electric field within its body to control voltage. (1)
- 1.6 The Darlington pair is also known as a ...
- A comparator.
  - B a super transistor.
  - C a super UJT.
  - D JFET. (1)

- 1.7 Pin 3 of a 555 Integrated Circuit (IC) is called the ...
- A +Vcc.
  - B ground.
  - C output.
  - D input. (1)
- 1.8 What will happen to the value of a light dependant resistor (LDR) if the light shining on it increases?
- A It will remain the same.
  - B It will first increase and then decrease.
  - C It will increase. (1)
  - D It will decrease.
- 1.9 Select the correct option with reference to a monostable multivibrator.
- A It is a free running oscillator.
  - B It has ONE input.
  - C The magnitude of the supply voltage determines the length the output is high.
  - D It will stay high indefinitely. (1)
- 1.10 An astable multivibrator has the following characteristics:
- A Free running with NO external inputs.
  - B Free running with TWO inputs.
  - C TWO stable states with TWO inputs.
  - D NO stable states with ONE input. (1)
- 1.11 A Schmitt trigger circuit works on the principle of:
- A Inverting signals
  - B Amplifying signals
  - C Hysteresis
  - D Adding the signals together (1)
- 1.12 Which ONE is NOT the application of RC coupled amplifier?
- A Radio or TV receivers
  - B RF communication
  - C Public address system as pre-amplifiers
  - D Improving the amplifiers stability (1)
- 1.13 Class B biasing of the transistor is biased with the Q point ...
- A right at the bottom of the load line.
  - B right in the middle of the load line.
  - C at the centre of the load line.
  - D at the top of the load line. (1)

- 1.14 The advantages of using a RC coupled amplifier is:
- A Cheap and compact
  - B Has low voltage and power gain as the effective load resistance is reduced
  - C Suitable at low-frequency application
  - D A radio frequency amplifier
- (1)
- 1.15 The Colpitts Oscillator is similar to a ...
- A Harley Oscillator circuit.
  - B Darlington Pair.
  - C FET.
  - D RC phase shift oscillator.
- (1)  
**[15]**

## QUESTION 2: OCCUPATIONAL HEALTH AND SAFETY

- 2.1 Define *major incident* with reference to the Occupational Health and Safety Act of 1993. (2)
- 2.2 State ONE cause of unsafe acts in a workshop. (1)
- 2.3 Describe why the following are unsafe acts or unsafe conditions:
- 2.3.1 Running in the workshop (2)
  - 2.3.2 Overloading electrical outlets with too many appliances (2)
- 2.4 Explain how you would conduct a qualitative risk analysis in your workshop at school. (3)
- [10]**

**QUESTION 3: RLC CIRCUITS**

3.1 Refer to FIGURE 3.1 below and answer the questions that follow.

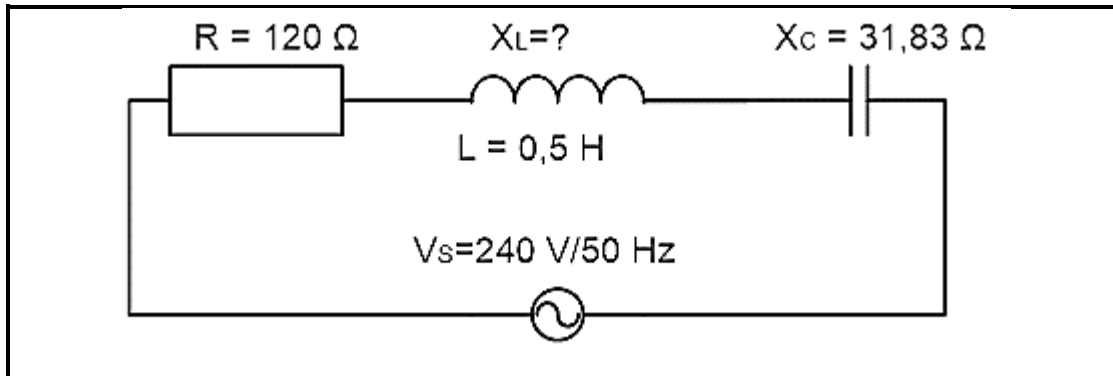

**FIGURE 3.1: SERIES RLC CIRCUIT**

Given:

$$R = 120 \Omega$$

$$L = 0,5 \text{ H}$$

$$X_C = 31,83 \Omega$$

$$V_S = 240 \text{ V}$$

$$f = 50 \text{ Hz}$$

- 3.1.1 State what would happen to the resistance if the frequency was doubled. (1)
- 3.1.2 Write down the value of  $X_L$  during resonance. (1)
- 3.1.3 Calculate the:
- Inductive reactance of the circuit (3)
  - Impedance of the circuit (3)
  - Voltage across the capacitor if a current of 1,38 A is flowing through the circuit (3)
  - Value of the capacitor required to achieve a capacitive reactance of  $42,44 \Omega$  (3)
  - Current flowing during resonance (3)
- 3.2 State the value of the supply current in a parallel RLC circuit during resonance. (1)

- 3.3 Define the term *bandwidth* of a resonant circuit. (2)
- 3.4 Mention TWO characteristics of a parallel RLC circuit. (2)
- 3.5 Refer to FIGURE 3.5 below and answer the questions that follow.

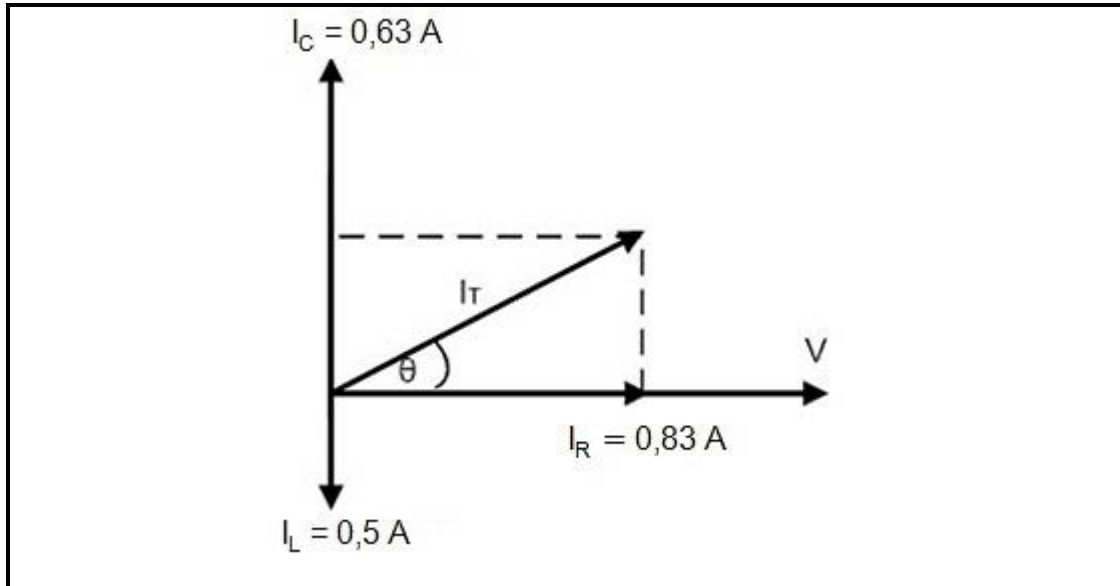

**FIGURE 3.5: PARALLEL RLC PHASOR DIAGRAM**

Given:

$$I_C = 0,63 \text{ A}$$

$$I_R = 0,83 \text{ A}$$

$$I_L = 0,5 \text{ A}$$

Calculate the:

- 3.5.1 Total current flowing through the circuit (3)
- 3.5.2 Voltage if the resistor has a value of  $120,487 \Omega$  (3)
- 3.5.3 Total impedance of the circuit (3)
- 3.5.4 Phase-angle and state whether the current is leading or lagging the voltage (4)

**[35]**

**QUESTION 4: SEMICONDUCTOR DEVICES**

- 4.1 Write the abbreviation JFET out in full. (1)
- 4.2 List TWO types of junction field effect transistors (JFETs). (2)
- 4.3 Explain how the construction of the JFET was modified to overcome the leakage current between the gate terminal and drain-source channel. (2)
- 4.4 Refer to FIGURE 4.4 below and answer the questions that follow.

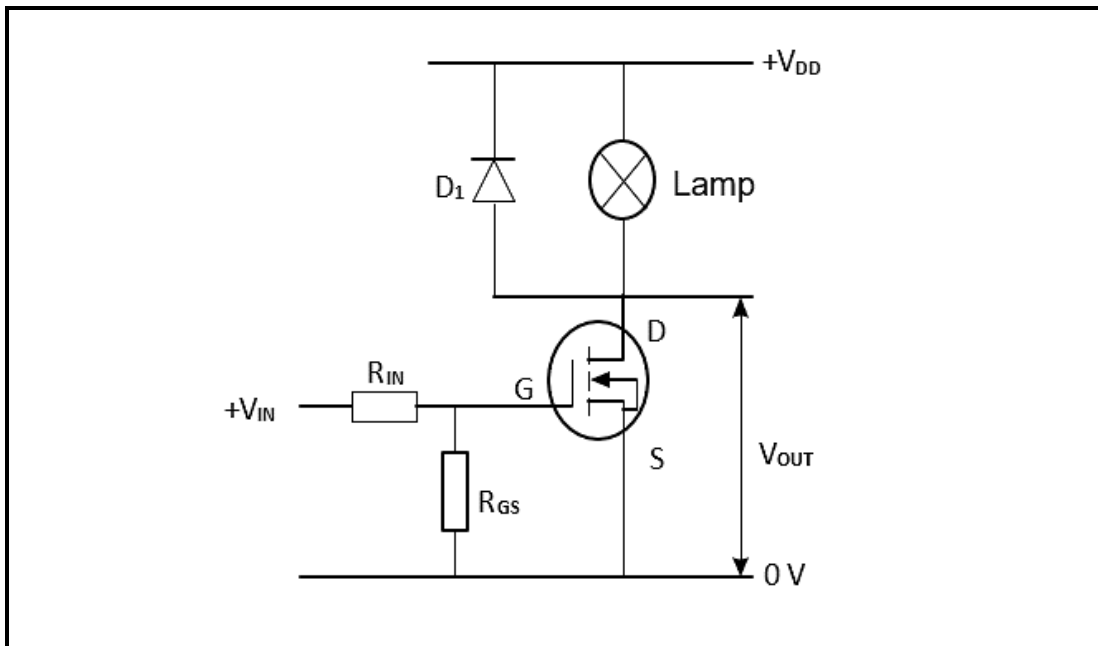
**FIGURE 4.4: MOSFET AS A SWITCH**

- 4.4.1 Identify the type of MOSFET used in this circuit. (2)
- 4.4.2 Describe when the lamp in this circuit will switch ON. (2)
- 4.4.3 Explain what will happen if  $R_{GS}$  is short-circuited. (3)



4.5 FIGURE 4.5 below shows the characteristic curve of a UJT. Answer the questions that follow.

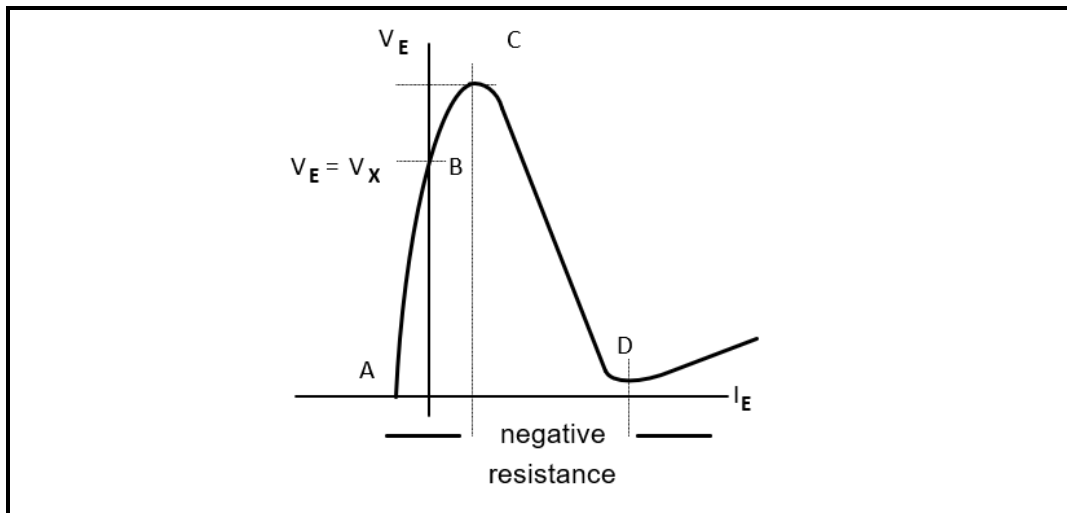

FIGURE 4.5: UJT CHARACTERISTIC CURVE

4.5.1 Identify region **A** and **D**. (2)

4.5.2 Explain what happens in the UJT between points **C** and **D** of the characteristic curve. (3)

4.6 Refer to FIGURE 4.6 below and answer the questions that follow.

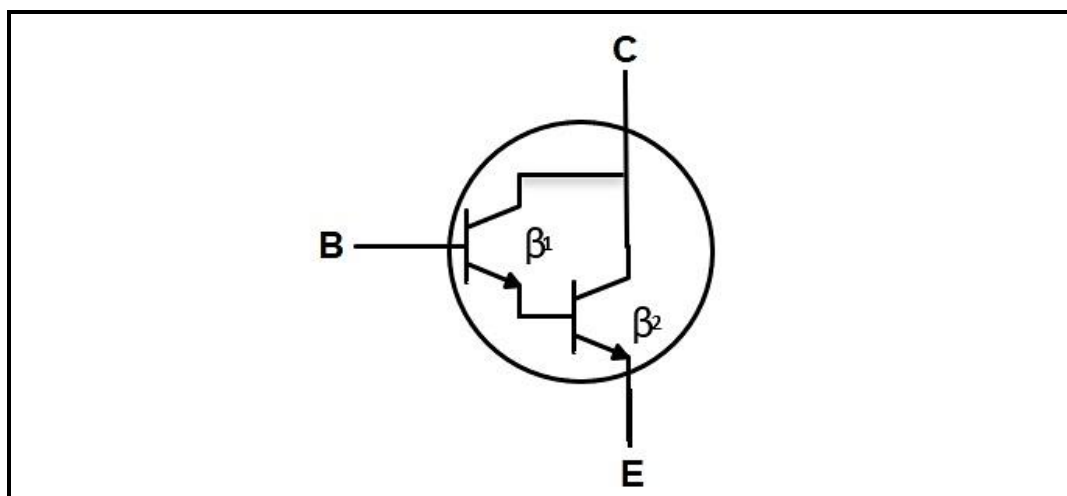

FIGURE 4.6: TRANSISTOR

4.6.1 Identify the configuration in which the transistors are connected. (1)

4.6.2 Explain TWO advantages of the transistor configuration in FIGURE 4.6. (2)

4.7 Name FOUR characteristics of an ideal operational amplifier. (4)

- 4.8 FIGURE 4.8 below shows the op amp as a non-inverting amplifier. Answer the questions that follow.

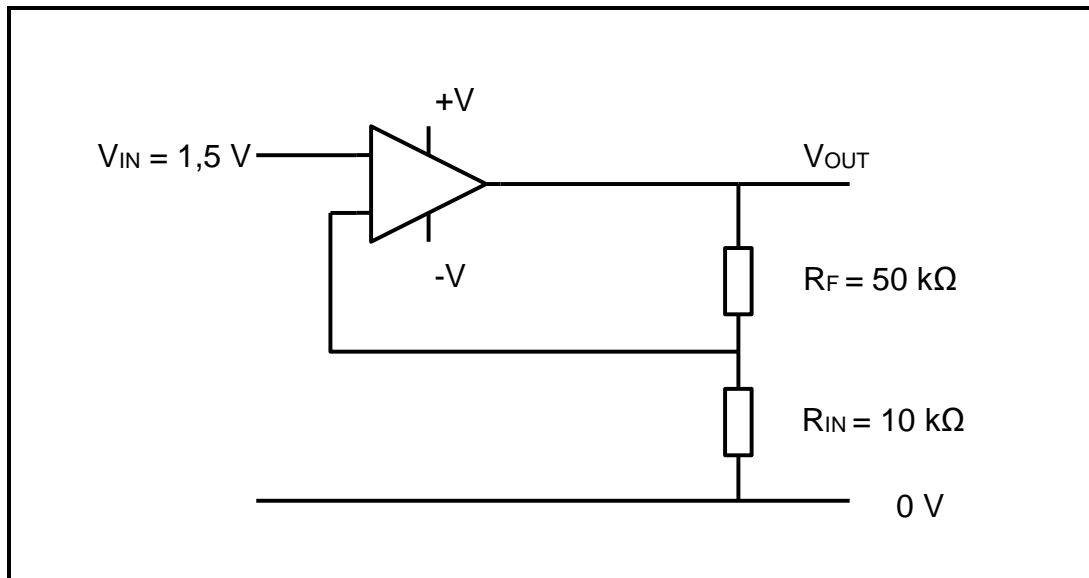

FIGURE 4.8: NON-INVERTING AMPLIFIER

Given:

$$V_{IN} = 1,5 \text{ V}$$

$$R_F = 50 \text{ k}\Omega$$

$$R_{IN} = 10 \text{ k}\Omega$$

- 4.8.1 Calculate the voltage gain in FIGURE 4.2. (3)
- 4.8.2 Calculate the output voltage. (3)
- 4.8.3 Describe the effects of decreasing the feedback resistor. (2)
- 4.9 With reference to the 555 timer IC, answer the questions below.
- 4.9.1 Explain the function of pin 6 (threshold) on a 555 IC. (3)
- 4.9.2 State the voltage parameters between which a 555 timer can operate. (2)
- 4.9.3 Explain the astable mode of operation of a 555 timer. (2)
- 4.9.4 Name ONE method to identify pin 1. (1)
- 4.10 Explain the difference between *open-loop gain* and *closed-loop gain* with reference to op amps. (2)
- 4.11 List THREE uses for the 555 IC. (3)

[45]

**QUESTION 5: SWITCHING CIRCUITS**

5.1 Refer to FIGURE 5.1 below, answer the following questions.

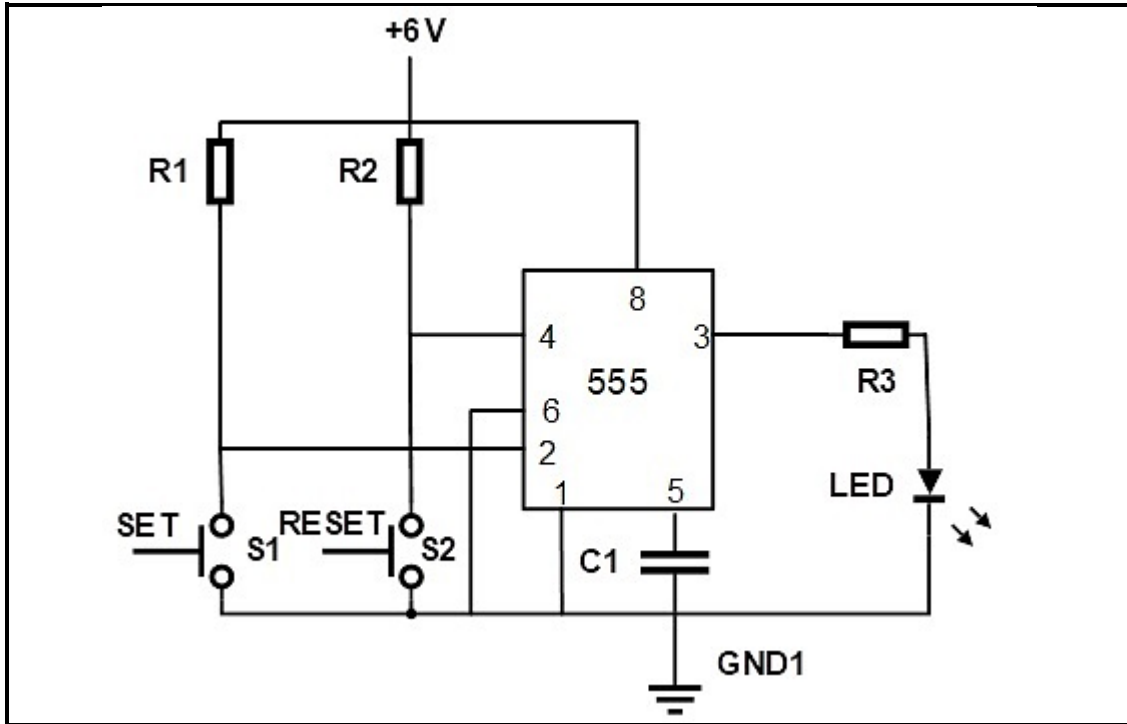

**FIGURE 5.1: BI-STABLE MULTIVIBRATOR**

- 5.1.1 Name TWO characteristics of the bi-stable multivibrator circuit in FIGURE 5.1 above. (2)
- 5.1.2 Explain what would happen in the circuit if R<sub>3</sub> were to be removed. (1)
- 5.1.3 Explain the importance (function) of R<sub>3</sub> in the circuit shown in FIGURE 5.1. (2)
- 5.1.4 Describe what happens when the SET switch, S<sub>1</sub> is pressed. (3)
- 5.1.5 Explain the function of R<sub>1</sub> and R<sub>2</sub> in the circuit. (2)
- 5.2 Draw a fully labelled circuit diagram for an astable multivibrator op amp circuit. (6)
- 5.3 With reference to an astable multivibrator op amp circuit, explain the term *feedback*. (3)
- 5.4 Name ONE application of a monostable multivibrator. (1)
- 5.5 Explain the principle of operation of a day/night switching circuit. (6)
- 5.6 Draw a fully labelled diagram of a typical hysteresis curve. (6)

- 5.7 Draw the output waveform of a 555 timer IC used as a Schmitt Trigger. Show at least TWO full cycles. (4)
- 5.8 FIGURE 5.8 and TABLE 5.8 below show the resistor values, output voltages and gain of a summing amplifier. Refer to FIGURE 5.8 and study TABLE 5.8 to answer the questions that follow.

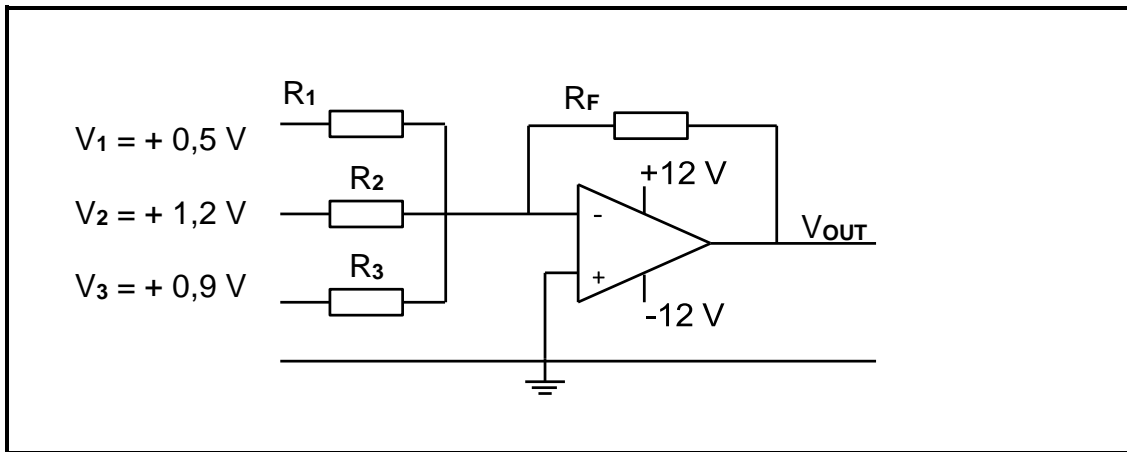

FIGURE 5.8: SUMMING AMPLIFIER

RESISTOR VALUES				OUTPUT	GAIN
R <sub>1</sub>	R <sub>2</sub>	R <sub>3</sub>	R <sub>F</sub>	V <sub>OUT</sub>	β (A <sub>v</sub> )
20 kΩ	20 kΩ	20 kΩ	20 kΩ	<b>B</b>	1
20 kΩ	20 kΩ	20 kΩ	40 kΩ	+ 5,2 V	<b>D</b>
5 kΩ	10 kΩ	20 kΩ	40 kΩ	<b>C</b>	4,08
20 kΩ	20 kΩ	20 kΩ	<b>A</b>	+ 10,4 V	4

TABLE 5.8

- 5.8.1 State the function of a summing amplifier. (2)
- 5.8.2 Calculate the output voltage at **B**. (3)
- 5.8.3 Calculate the output voltage at **C**. (3)
- 5.8.4 Calculate the value of the feedback at **A**. (3)
- 5.8.5 Calculate the total gain at **D**. (3)

[50]

**QUESTION 6: AMPLIFIERS**

- 6.1 Describe class A amplification with reference to the biasing of a transistor. (2)
- 6.2 Refer to FIGURE 6.2 below and answer the questions that follow.

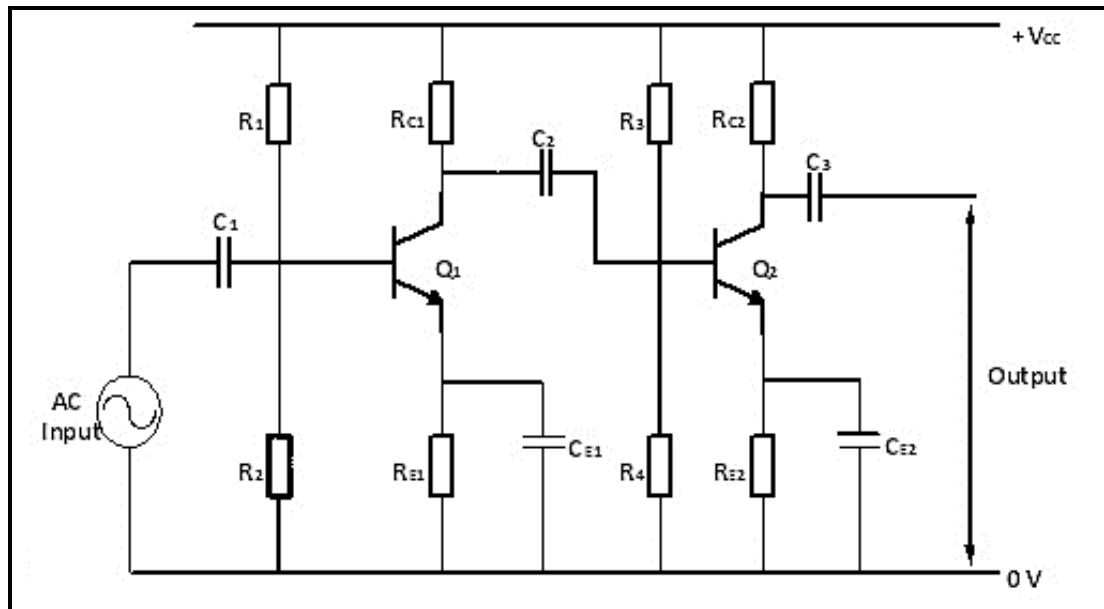

**FIGURE 6.2: RC-COUPLED AMPLIFIER**

- 6.2.1 Name TWO functions of capacitor  $C_2$ . (2)
- 6.2.2 Explain the operation of an RC-coupled amplifier. (6)
- 6.2.3 State TWO requirements of the coupling of amplifier stages. (2)

6.3 Analyse FIGURE 6.3 below and answer the questions that follow.

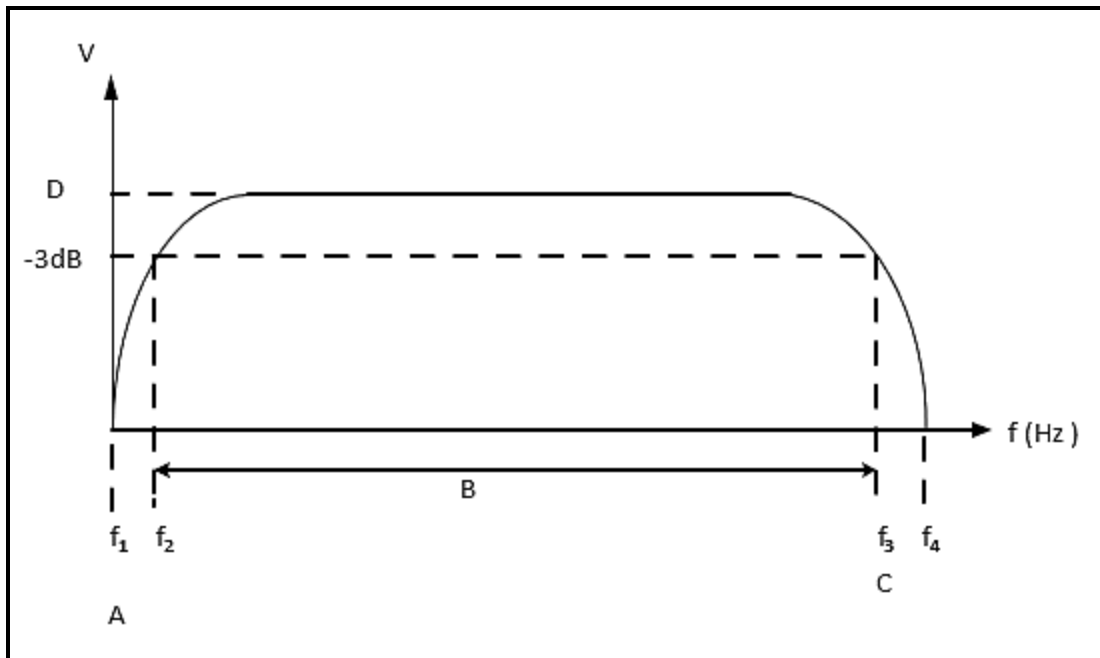

**FIGURE 6.3: FREQUENCY RESPONSE OF RC-COUPLED AMPLIFIER**

- 6.3.1 Label points **A**, **B**, **C** and **D**. (4)
- 6.3.2 Define the term *frequency response* with reference to amplifiers. (2)
- 6.3.3 Describe how the voltage gain of an RC-coupled amplifiers are affected at low frequencies. (3)

6.4 Refer to FIGURE 6.4 below and answer the questions that follow.

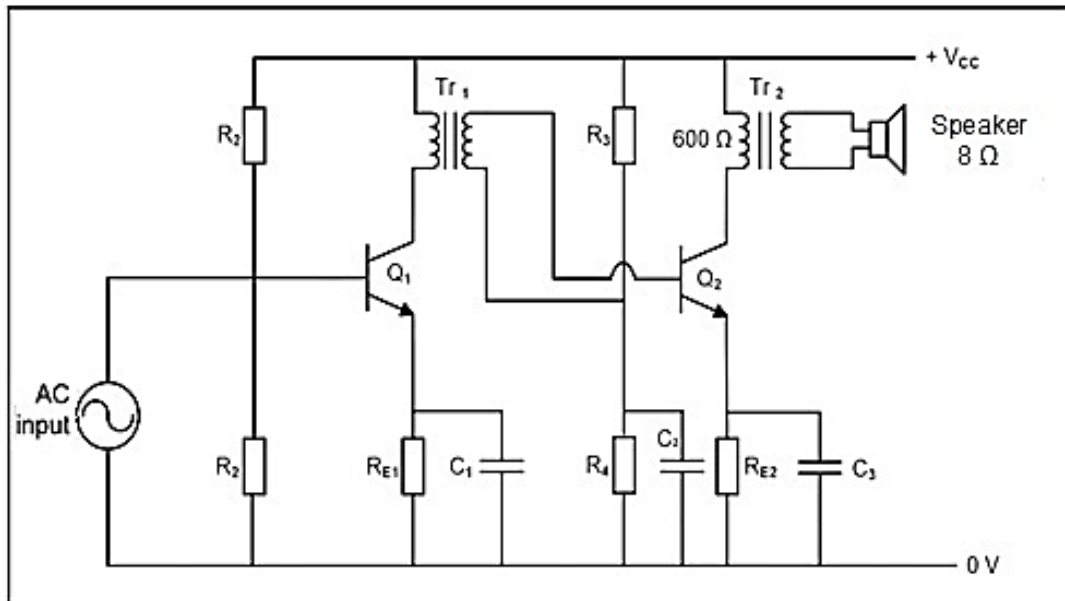

**FIGURE 6.4: TRANSFORMER-COUPLED AMPLIFIER**

- 6.4.1 State how the circuit must be modified if the loudspeaker is changed to a lower-impedance loudspeaker. (2)
- 6.4.2 Explain why a transformer is used at the output of the amplifier. (3)
- 6.4.3 State TWO disadvantages of a transformer-coupled amplifier. (2)

6.5 Refer to FIGURE 6.5 below and answer the questions that follow.

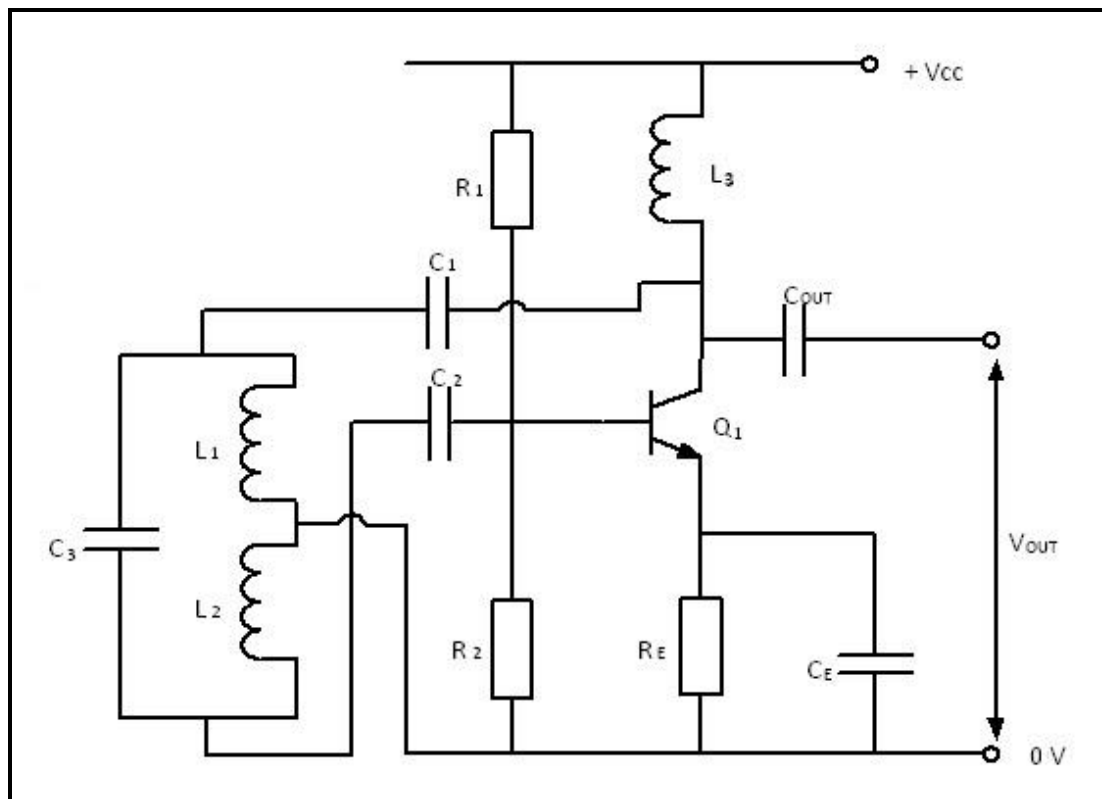

**FIGURE 6.5: HARTLEY OSCILLATOR**

- 6.5.1 Define the term *oscillator*. (2)
- 6.5.2 Explain the function of the RF coil in the oscillator circuit. (3)
- 6.5.3 State the purpose of resistors  $R_1$  and  $R_2$  in the circuit. (2)
- 6.5.4 Differentiate between the *Hartley oscillator* and the *Colpitts oscillator*. (2)
- 6.5.5 Describe how oscillation is achieved in the circuit. (6)
- 6.5.6 State the equation for the frequency of oscillation of a tank circuit. (2)

**[45]**

**TOTAL: 200**



**FORMULA SHEET**

**RLC CIRCUIT**

$$X_L = 2\pi FL \text{ and } X_C = \frac{1}{2\pi FC}$$

**SERIES**

$$I_T = I_R = I_C = I_L$$

$$Z = \sqrt{R^2 + (X_L - X_C)^2}$$

$$V_T = \sqrt{V_R^2 + (V_L - V_C)^2}$$

$$V_L = IX_L \text{ and } V_C = IX_C \text{ and } V_T = IZ$$

$$\cos\theta = \frac{R}{Z}$$

$$\cos\theta = \frac{V_R}{V_T}$$

$$Q = \frac{X_L}{Z} = \frac{X_C}{Z} = \frac{V_L}{V_S} = \frac{V_C}{V_S} = \frac{1}{R} \sqrt{\frac{L}{C}}$$

**PARALLEL**

$$1. V_T = V_R = V_L = V_C$$

$$2. I_R = \frac{V}{R} \text{ and } I_L = \frac{V}{X_L} = I_C = \frac{V}{X_C}$$

$$3. I_T = \sqrt{I_R^2 + (I_L - I_C)^2}$$

$$4. \cos\theta = \frac{I_R}{I_T}$$

$$5. Q = \frac{X_L}{Z} = \frac{X_C}{Z} = \frac{V_L}{V_S} = \frac{1}{R} = \sqrt{\frac{L}{C}}$$

**SEMI-CONDUCTORS DEVICES**

$$A_V = \frac{V_{out}}{V_{in}} = \frac{R_F}{R_{IN}}$$

$$V_{OUT} = V_{IN} = \left(-\frac{R_F}{R_{IN}}\right)$$

$$A_V = 1 + \frac{R_F}{R_{IN}}$$

$$V_{OUT} = V_{IN} \left(1 + \frac{R_F}{R_{IN}}\right)$$

$$\beta_{super} = \beta_1 \times \beta_2$$

**AMPLIFIERS**

$$V_{CE} = V_{CC}$$

$$I_{Cmax} = \frac{V_{CC}}{R_C}$$

$$A' = \frac{A}{1 + \beta A}$$

$$\text{Power Gain } A_P = \log_{10} \left(\frac{P_{out}}{P_{in}}\right)$$

$$A_V = 20 \log_{10} \frac{E_{out}}{E_{in}} \text{ dB}$$

$$A_I = 20 \log_{10} \frac{I_{out}}{I_{in}}$$

$$F_0 = \frac{1}{2\pi\sqrt{L_T C}}$$

$$F_r = \frac{1}{2\pi\sqrt{LC}}$$

$$F_O = \frac{1}{2\pi\sqrt{6RC}}$$

**SWITCHING CIRCUITS**

1. Gain  $A_V = \frac{V_{OUT}}{V_{IN}} = -\left(\frac{R_f}{R_{in}}\right)$  inverting operational amplifier

2. Gain  $A_V = \frac{V_{OUT}}{V_{IN}} = 1 + \left(\frac{R_f}{R_{in}}\right)$  non-inverting operational amplifier

3.  $V_{OUT} = V_{IN} \times \left(-\frac{R_f}{R_{in}}\right)$  inverting amplifier

4.  $V_{OUT} = -(V_1 + V_2 + V_3)$  summing up op-amp

5.  $f_r = \frac{1}{2\pi\sqrt{LC}}$

6.  $f = \frac{1}{2\pi\sqrt{6RC}}$