



Life Sciences

SELF STUDY GUIDE 1

DNA – CODE OF LIFE & MEIOSIS

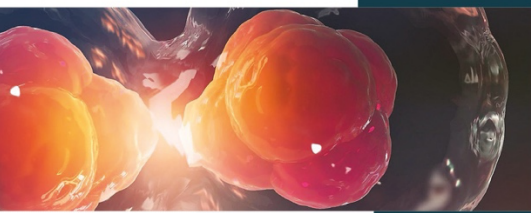
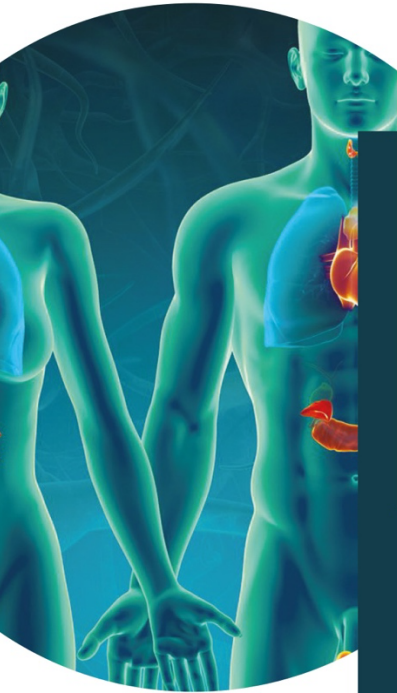

TABLE OF CONTENTS		PAGE
1.	Introduction	3
2.	How to use this Self-study Guide	4
3.	DNA: The Code of Life	5
	3.1 Mind map on DNA - Code of life	5
	3.2 Links to prior-knowledge/background knowledge	6
	3.3 Practice questions on prior-knowledge	7-8
	3.4 Differentiate between related terminologies	9-12
	3.5 DNA Replication – exam tips/techniques/notes	13
	3.6 Practice questions on DNA Replication	14
	3.7 DNA profiling – exam tips/techniques/notes	15
	3.8 Practice questions on DNA Profiling	17
	3.9 Protein Synthesis – exam tips/techniques/notes	18
	3.10 Practice questions on DNA Replication and Transcription	19
	3.11 Genetic Coding – exam tips/techniques/notes	20
	3.12 The effect of mutation on protein structure (DNA sequence) exam tips/techniques/notes	22
	3.13 Practice questions on mutation and Protein structure	25
	3.14 Typical exam questions	28
	3.15 Solutions to DNA practice questions	37
4.	Meiosis	41
	4.1 Mind map on Meiosis	42
	4.2 Links to prior-knowledge/background knowledge	43
	4.3 Differentiate between related terminologies	44
	4.4 Process of meiosis - exam tips/techniques/notes	48
	4.5 Practical questions on Meiosis	52
	4.6 Typical exam questions	60
	4.7 Solutions to DNA practice questions	64
5.	References	66
6.	Acknowledgement	66

1. INTRODUCTION

The declaration of COVID-19 as a global pandemic by the World Health Organisation led to the disruption of effective teaching and learning in many schools in South Africa. The majority of learners in various grades spent less time in class due to the phased-in approach and rotational/ alternate attendance system that was implemented by various provinces. Consequently, most schools were not able to complete all the relevant content designed for specific grades in accordance with the Curriculum and Assessment Policy Statements in most subjects.

As part of mitigating against the impact of COVID-19 on the current Grade 12, the Department of Basic Education (DBE) worked in collaboration with subject specialists from various Provincial Education Departments (PEDs) developed this Self-Study Guide. The Study Guide covers those topics, skills and concepts that are located in Grade 12, that are critical to lay the foundation for Grade 12. The main aim is to close the pre-existing content gaps to strengthen the mastery of subject knowledge in Grade 12. More importantly, the Study Guide will engender the attitudes in the learners to learning independently while mastering the core cross-cutting concepts.

2. HOW TO USE THIS SELF STUDY GUIDE

- There are five Self-study guides covering all Grade 12 topics:
 - **Booklet One: DNA: Code of Life and Meiosis**
 - Booklet Two: Reproduction in Vertebrates, Human reproduction, Endocrine System and Homeostasis
 - Booklet Three: Genetics and Inheritance
 - Booklet Four: Responding to the Environment: Humans and Plants
 - Booklet Five: Evolution: Natural Selection and Human evolution
- You must use this Self-study Guide together with the *Life Sciences Mind the Gap Study Guide*, which is a complementary booklet.
- You need to study the content from the *DBE Grade 12 Textbook*, *DBE Exam Guideline 2021*, and *Mind the Gap* for all the topics.
- Ensure you understand all the relevant concepts and content.
- This Self-study Guide focusses mainly on the skills you will need to answer the questions in examinations.
- There are exam technique and tips for each topic (*in italics*)
- These tips will guide you on how to approach certain types in the Life Sciences Examination papers and tests:
 - How to master the relevant terminology
 - Drawing and interpreting of graphs
 - Interpreting tables
 - Interpreting diagrams
 - Genetics crosses and pedigree diagrams
 - Doing calculations
 - Scientific investigation questions
- At the end of each booklet you will find typical examination questions and answers

DNA - CODE OF LIFE

TOPIC: DNA – CODE OF LIFE			
TERM	1	PAPER	2
DURATION	8 hours (2 weeks)	WEIGHTING	27 marks (18%)
PRIOR-KNOWLEDGE/BACKGROUND KNOWLEDGE			
Grade 10: Plant and Animal cells, proteins, nucleic acids, location of DNA and chromosome.			
RESOURCES			
Textbooks, Study Guides, MTG, Past NSC, SC & Provincial Question Papers			

3.1 MINDMAP ON DNA - CODE OF LIFE

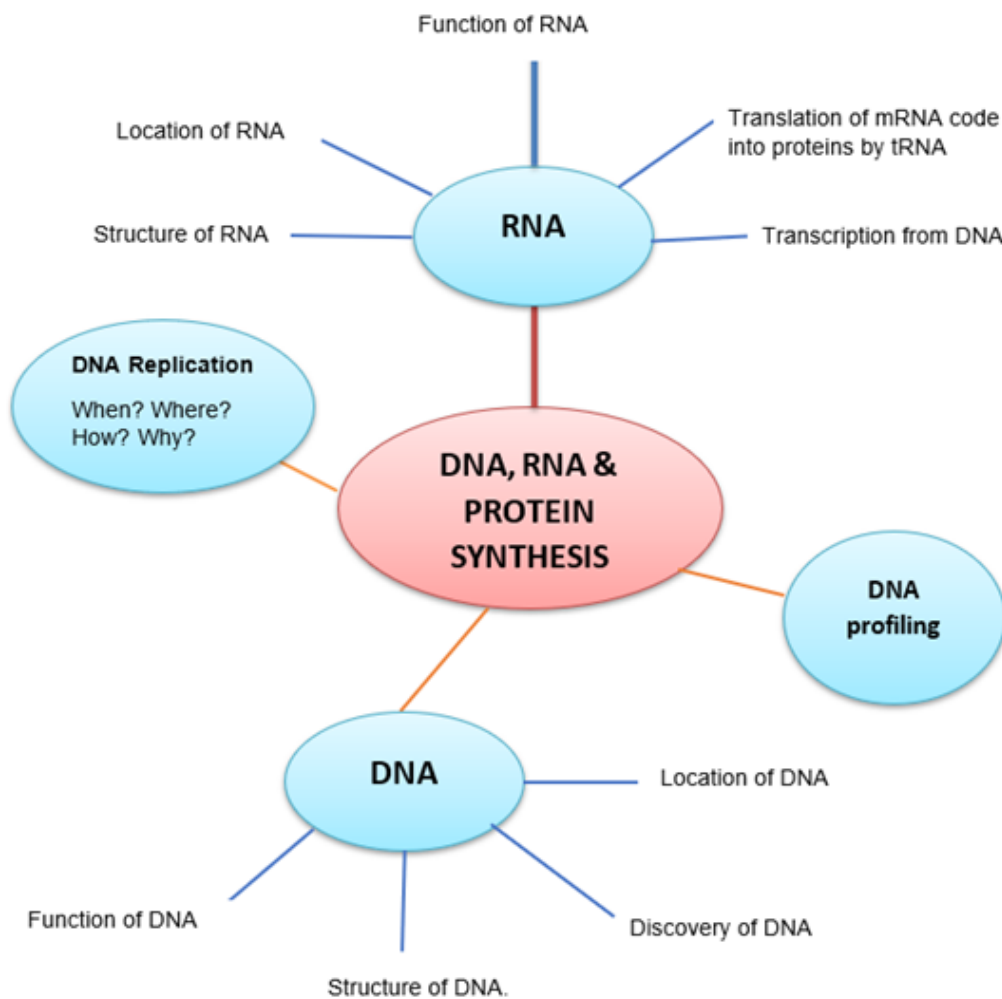

3.2 LINKS TO PRIOR-KNOWLEDGE/BACKGROUND KNOWLEDGE

It is important to know the location, composition and function of the ribosome, cytoplasm and the parts of the nucleus (nuclear membrane, nucleoplasm, nucleolus, chromatin network).

Structure of a cell

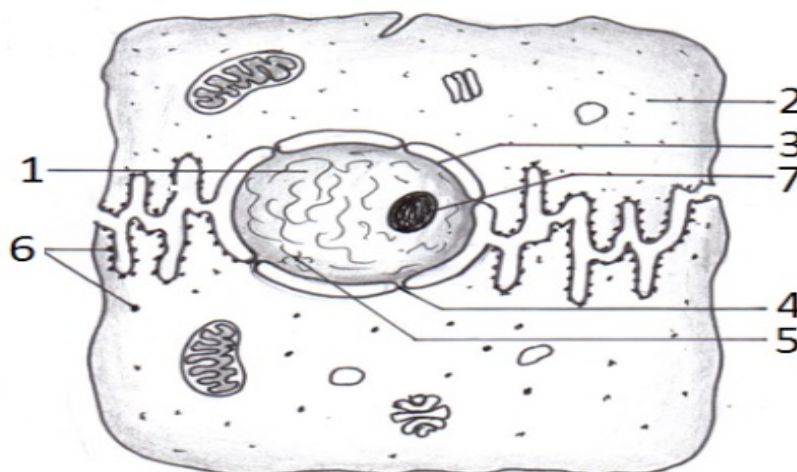

CELL STRUCTURE	LOCATION	COMPOSITION	FUNCTION
1.Nucleoplasm/ Nuclear sap	In the cell nucleus	The nucleoplasm is a liquid that surrounds the chromosomes and nucleoli.	Many substances such as free nucleotides (necessary for purposes such as the replication of DNA) and enzymes (which direct activities that take place in the nucleus) are dissolved in the nucleoplasm.
2. Cytoplasm	Fluid part of cell outside the nucleus and inside the cell membrane. The area between the plasma/cell membrane and nucleus.	Filled with a clear fluid called CYTOSOL. Contains many structures called ORGANELLES	Where most metabolic reactions/activities take place.
3. Nuclear Membrane/ Envelope	Enclosing the nucleus	Thin wall double membrane	Controls what goes in and out of nucleus
4. Nuclear pore	Tiny holes found in the nuclear envelope	Tiny holes (openings)	Help to regulate the exchange of materials (such as mRNA and proteins) between the nucleus and the cytoplasm.
5. Chromatin network	In the cell nucleus	Tangled, threadlike material	Forms the chromosomes, the chromosomes are the basis of the hereditary functions of the cell, there are 46 chromosomes in human cells (except mature sex cells in which there are 23)

6. Ribosome	Found along the endoplasmic reticulum Some ribosomes are found in the cytoplasm	Ribosomes are made up of some protein and RNA.	Makes protein for the cell (the site of protein synthesis)
7. Nucleolus	Small, dense structures within nucleus	Made of proteins and RNA. No membrane	Produces ribosomes

3.3 PRACTICE QUESTIONS on PRIOR-KNOWLEDGE

Question 1: The basic structure of the cell and nucleus

1.1 Study the following diagrams and answer the questions:

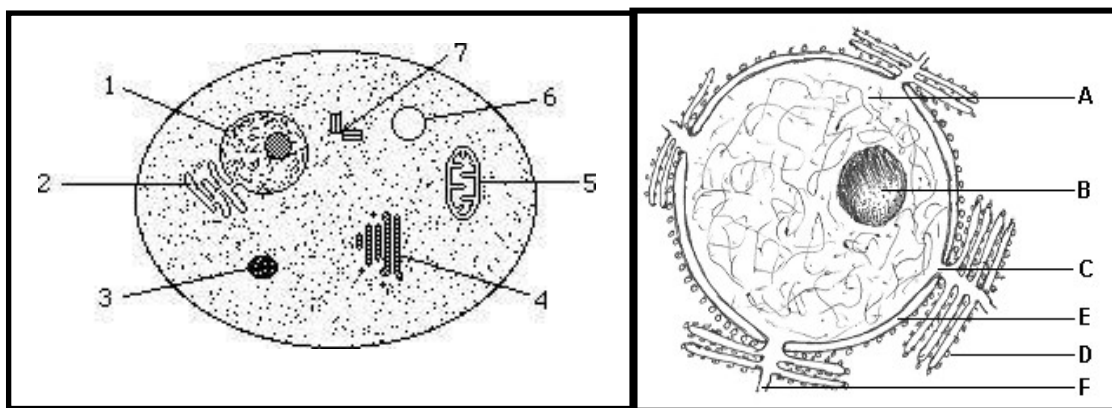

Diagram A

Diagram B

1.1.1 Identify the organelle (number and name) in Diagram A that is represented by Diagram B. 1✓ - nucleus✓

1.1.2 Give the:

(a) **Two nucleic acids present in Diagram B.**

- DNA✓ (Deoxyribonucleic acid)
- RNA ✓ (Ribonucleic acid)

(b) **Significance of the organelle represented in Diagram B.**

The nucleus controls all of the cell's activities.✓

- (c) **Way in which substances get into and out of the organelle represented by diagram B**

The nuclear envelope has nuclear pores✓ that allow substances to enter and exit the nucleus.

1.1.3 **Identify label D.** Ribosome✓

1.1.4 **Complete the table with regard to the location, composition and function of label D.**

LOCATION	COMPOSITION	FUNCTION OF ORGANELLE
Found along the endoplasmic reticulum✓ Some ribosomes are found in the cytoplasm✓	Ribosomes are made up of some protein✓ and RNA.✓	Makes protein✓ for the cell (the site of protein synthesis)

1.1.5 **Identify the following labelled organelles and give the function of each.**

LABEL NUMBER	NAME OF ORGANELLE	FUNCTION OF ORGANELLE
5	Mitochondria ✓	Make energy✓ through cellular respiration
6	Vacuole ✓	Stores water, metabolic waste products and pigments✓
7	Centrosome✓ 	Helps in cell division✓ Assures equal distribution of chromosomes in daughter cells. ✓

Note:

A centrosome is made of two separate centrioles. Centrioles are present in animal cells but not in plant cells.

3.4 DIFFERENTIATE BETWEEN RELATED TERMINOLOGIES

NUCLEOLUS	NUCLEOPLASM	CYTOPLASM	RIBOSOME
Structure in the nucleus responsible for forming ribosomal RNA	That part of the protoplasm within the nucleus	That part of the protoplasm outside the nucleus.	Structure that is the site of protein synthesis

CHROMATIN	CHROMATID	CENTROMERE	CHROMOSOME	CHROMATIN NETWORK
The DNA-containing network found in cells in interphase (non-dividing)	The individual threads that form a chromosome	Structure that holds two chromatids together in a replicated chromosome and which also attaches the chromosome to the spindle fibres during cell division	It is a thread like structure made up of DNA/that carries hereditary information in the form of genes	Visible as thread-like structures in the nucleus of an inactive cell

DNA (DEOXYRIBONUCLEIC ACID)	RNA (RIBONUCLEIC ACID)
Forms the chromosomes in the nuclei of all living cells and carries the hereditary information of the organism. The DNA molecule is a double helix (twisted) strand.	A single strand, located in the nucleoplasm and cytoplasm. The RNA molecule is always a single strand of nucleotides. Remember that the RNA contains Uracil instead of Thymine (A, G, C and U). RNA is responsible for protein synthesis.
HELIX	
Coiled (natural) shape of a DNA molecule	

MONOMER	POLYMER
A single unit that makes up a larger molecule	A large molecule which is formed from many small molecules (monomers)
NUCLEOTIDE	
The building block (monomers) of RNA and DNA. Each nucleotide consists of a pentose sugar, a phosphate ion and a nitrogenous base.	
AMINO ACID	
The basic building block (monomer) of a protein molecule	
ENZYME	
A protein that speeds up a chemical reaction / a catalyst	

CYTOSINE	THYMINE	URACIL
The base that pairs off with guanine	The base that pairs off with adenine	The base found in RNA and not DNA
NITROGENOUS BASES		
These are nitrogen containing molecules viz. Adenine, (A); Thymine (T); Guanine (G); Cytosine (C) and Uracil (U).		
BASE PAIRING		
Adenine (A) always bonds to thymine (T) and guanine (G) with cytosine (C) in DNA molecule, to ensure the precision of DNA replication		

MITOCHONDRIAL DNA	NUCLEAR DNA	CHLOROPLAST DNA
The type of DNA found only in the mitochondrion	Type of DNA found in the nucleus – makes up genes on chromosomes	Type of DNA found in chloroplasts (plants)

TEMPLATE	COMPLEMENTARY STRAND
The original strand that provides a framework upon which a new strand is developed	The new strand that is made based on the sequence of nucleotides on the template
DNA REPLICATION	
Process involving the formation of two new identical DNA molecules <u>from an original DNA</u> .	

TRANSCRIPTION	TRANSLATION
1 st stage of protein synthesis The synthesis of mRNA from a DNA template	2 nd stage of protein synthesis The process of converting the information carried by m-RNA to the correct sequence of amino acids to form a particular protein

SYNTHESIS

Building up of separate parts into a whole

MESSENGER RNA (MRNA):	RIBOSOMAL RNA (RRNA)	TRANSFER RNA (TRNA)
Responsible for carrying the genetic code that is transcribed from DNA, to specialized sites of the ribosomes where the information is translated for protein synthesis	Form the ribosomes and produce the proteins, based on the information received from the tRNA	Has anticodons, which codes for a specific amino acid. The anticodons are complementary to the mRNA codon, during the production of proteins.
Carries codons	Lacks codons or anticodons	Carries anticodons

CODON	ANTICODON
The three adjacent bases found on a mRNA molecule.	The three adjacent bases found on a tRNA molecule that will determine which amino acid will be brought to the ribosome.
One mRNA molecule contains a number of codons.	One tRNA molecule contains one anticodon.

HYDROGEN BONDS	PEPTIDE BOND
The chemical bonds which link base pairs in the DNA molecule	A link between two adjacent amino acids

GENE	GENOME
Segment of a chromosome that controls each characteristic/ a unit of sequenced pieces of DNA that carry the genetic information that will determine the hereditary characteristics of an organism.	All the genes present in an organism
HEREDITARY	
Characteristics that are passed from parents to offspring	
MUTATION	
A sudden change in the DNA nucleotide sequence	

3.5 DNA REPLICATION – EXAM TIPS/TECHNIQUES/NOTES

How does DNA replication occur? – The Process of DNA Replication

1. The DNA double helix unwinds

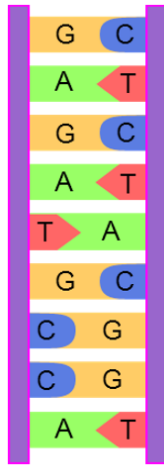

2. The weak hydrogen bonds between the nitrogenous bases are broken. The DNA strands separate (they unzip)

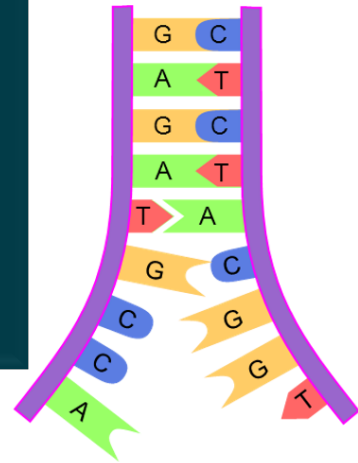

3. Each original DNA strand serves as a template on which its complement is built

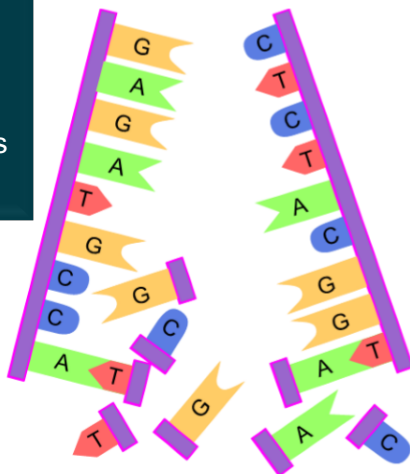

4. Free nucleotides build a DNA strand onto each of the original DNA strands, attaching their complementary nitrogenous bases (A to T and C to G)

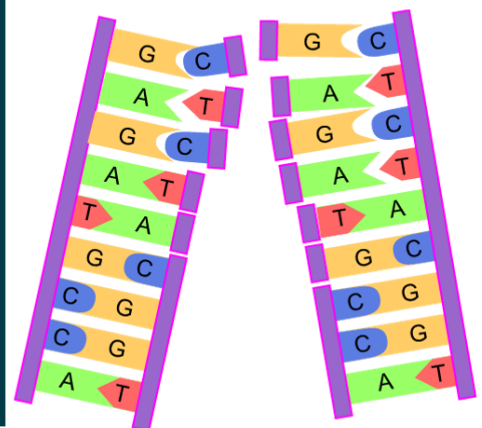

5. This result in two identical DNA molecules. Each molecule consists of one original strand and one new strand

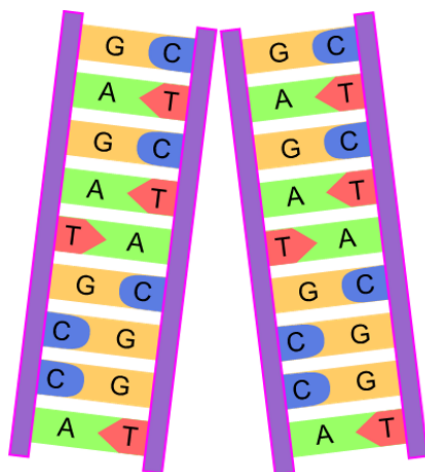

ERRORS that occur during DNA replication may sometimes lead to **mutations** (a change in the nitrogenous base sequence)

If the incorrect nitrogen base attaches to the original strand (i.e., if a nitrogen base is added or deleted: the sequence or order of the bases changes on the new DNA molecule resulting in a change in the gene structure (**gene mutation**))

3.6 PRACTICE QUESTIONS on DNA REPLICATION

Question 2: DNA Replication

2.1 Number the steps of DNA replication in the correct order (1, 2, 3, 4 and 5):

 3 Each original DNA strand serves as a template on which its complement is built.

 1 The double helix unwinds.

 5 Two identical DNA molecules are formed.

 2 Weak hydrogen bonds between nitrogenous bases break and two DNA strands unzip (separate).

 4 Free nucleotides build a DNA strand onto each of the original two DNA strands by attaching to their complementary nitrogenous bases.

2.2 Show the complimentary base pairing that would occur in the replication of the short DNA molecule below. Use two different coloured pencils (or different pens, markers, etc.) to show which strands are the original and which are newly synthesized. Also indicate the nitrogenous base.

Original DNA strand 1	Original DNA strand 2	→	Original DNA strand 1 (copy from left)	New DNA strand	+	New DNA strand (copy from left)	Original DNA strand 2
A	T	→	A	T	+	A	T
C	G	→	C	G	+	C	G
C	G	→	C	G	+	C	G
T	A	→	T	A	+	T	A
G	C	→	G	C	+	G	C
A	T	→	A	T	+	A	T
T	A	→	T	A	+	T	A
C	G	→	C	G	+	C	G
G	C	→	G	C	+	G	C
T	A	→	T	A	+	T	A

(a) **When and where does DNA replication take place?**

This occurs during interphase ✓ of the cell cycle in the nucleus ✓.

(b) **Why is the process of DNA replication important?**

- Doubles the genetic material ✓ so it can be shared between the resulting daughter cells during cell division.
- Results in the formation of identical daughter cells ✓ during mitosis.

(c) **Give TWO functions of DNA?**

- Sections of DNA forming genes carry hereditary information ✓
- DNA contains coded information for protein synthesis ✓

3.7 DNA PROFILING – EXAM TIPS/TECHNIQUES/NOTES

What is DNA Profiling?

When we talk about **DNA profiling**, we no longer refer to the pattern of bars as a DNA fingerprint.

A **DNA profile** is a pattern produced on X-ray film.

This pattern consists of lines which are of different lengths and thicknesses and in different positions.

All individuals, except identical twins, have a unique DNA profile.

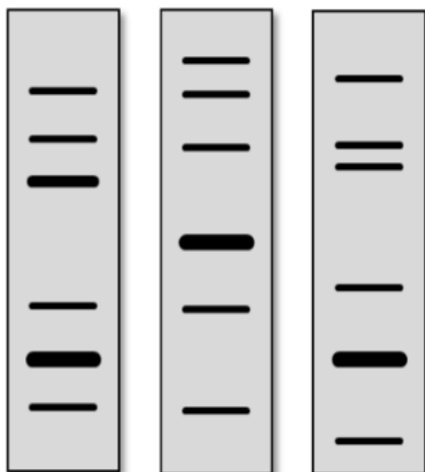

DNA profiles for three different individuals

Compare the DNA profiles (bands/bars) of two samples – an unknown or *evidence* sample, such as semen, saliva, blood, hair strands, skin, finger or toenails, tooth with root material, etc. and a known or *reference* sample, such as a blood sample from a suspect.

If most of the DNA bands/bars from evidence sample is matching that of the reference sample, they're the same DNA. The analysis of the results of the DNA profiling may lead to various conclusions depending on the aim of the DNA profiling (eg. crime suspect, relatives, compatibility of tissue types and probability or causes of genetic defects).

Use a ruler to guide you, move down the column while looking at the spacing of the bands, their thickness. (Remember, the bands are not necessarily even spaced, and some are darker and/or thicker than others).

DNA profiles are used to:

- Prove paternity (father) and maternity (mother) (biological parents)
- Determine the probability or causes of genetic defects
- Establish the compatibility of tissue types for organ transplants
- Identify relatives
- Identify crime suspects in forensic investigations (Forensic Pathologists is a person that performs DNA tests on biological evidence collected at crime scenes)

The role of DNA profiling in paternity testing

(NB: This section is normally covered under genetics)

<ul style="list-style-type: none">• A child received DNA from both parents• When working out the possible father in paternity testing, you MUST compare the 'bands' of the DNA profiles of the mother, child and possible father using the following steps:• Step 1: A comparison of the DNA bands of the mother and the child is made• Step 2: The remaining DNA bands are compared to the possible father's DNA bands	
<ul style="list-style-type: none">• If all the remaining DNA bands in the child's profile match the possible father's DNA bands	<ul style="list-style-type: none">• If all the remaining DNA bands in the child's profile does not match the possible father's DNA bands
<ul style="list-style-type: none">• then the possible father is the biological father	<ul style="list-style-type: none">• then the possible father is not the biological father

3.8 PRACTICE QUESTIONS on DNA PROFILING

Question 3: DNA Profiling

3.1 The diagram below shows the DNA profiles of a child, her mother and four males. There is uncertainty about who the biological father is. To establish paternity, DNA profiling was conducted.

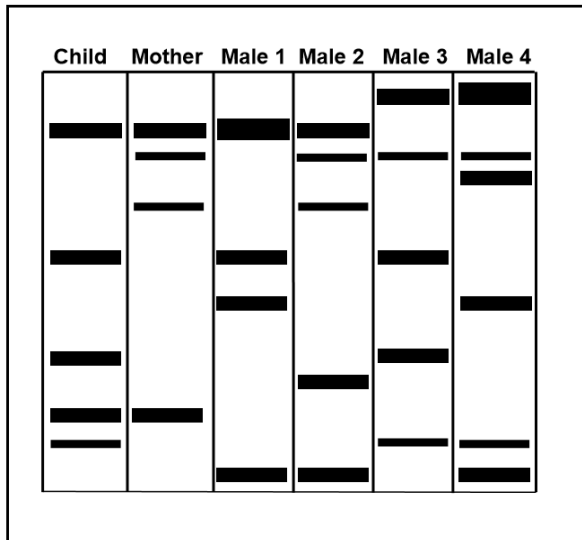

(a) Which male is the biological father of this child? Male 3✓

(b) Explain precautions that should be taken when working with DNA samples in a laboratory.

- Mark the samples clearly✓ to make sure vials are not swapped.✓
- Wear gloves and a mask✓ not to contaminate samples✓ with your own DNA
- Use new and clean/sterilised apparatus✓ not to contaminate samples✓.

3.2 The diagram below shows the DNA profiles of six different people.

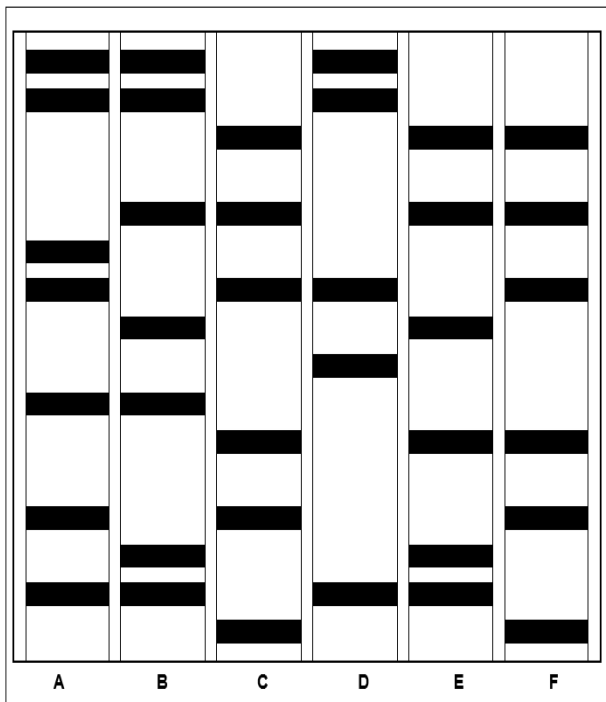

(a) Give the letters of the TWO people who are identical twins. C✓ and F✓

(b) Give the letters of the parents of person B. A✓ and E✓

(c) Explain whether the collection of DNA from every citizen in South Africa to create a DNA profile database for South Africa is a good idea or not.

No✓. DNA profiles may reveal personal information about a person which could be used against them in a prejudicial way✓.

OR

Yes✓. It could be used to identify crime suspects and relatives, assist in organ transplant, determining the causes of genetic defects or prove parenthood.✓

3.9 PROTEIN SYNTHESIS – EXAM TIPS/TECHNIQUES/NOTES

PROTEIN SYNTHESIS is the process by which proteins are made in each cell of an organism to form enzymes, hormones and new structures for cells. There are two main processes involved in protein synthesis, namely: **Stage 1: Transcription** of mRNA from DNA and **Stage 2: Translation** of mRNA to form proteins

TRANSCRIPTION (takes place in the nucleus)

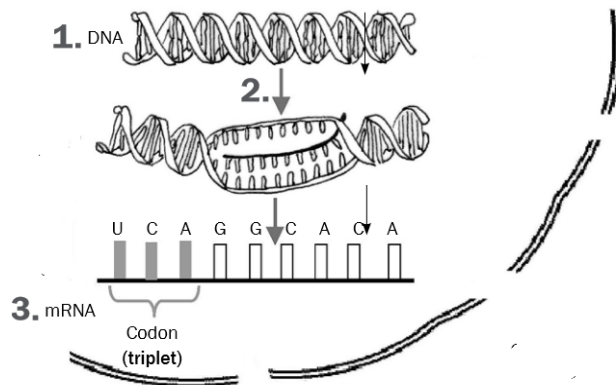

1. A section of the **DNA double helix unwinds**. The double-stranded DNA unzips/weak hydrogen bonds break to form two separate strands.
2. **One strand is used as a template**
3. Free RNA nucleotides arrange to **form a complementary strand of mRNA** according to the DNA template. This process is called **transcription**.

The mRNA now contains the **code for the protein** which will be formed. Three adjacent nitrogenous bases on the mRNA are known as **codons**. These code for a particular amino acid.

TRANSLATION (takes place in the cytoplasm on the ribosome)



4. The **mRNA leaves the nucleus** through the nuclear pores into the cytoplasm and **attaches to the ribosome**.
5. Transfer RNA (tRNA) in the cytoplasm has three adjacent nitrogenous bases known as the **anti-codon**. The mRNA's codon will be complementary to a tRNA's anti-codon. Each **tRNA brings a specific amino acid to the ribosome**. This is called **translation**. The amino acids are linked together to form a particular protein.

NOTE: You might not necessarily be asked to explain the entire process of Protein Synthesis but only sections of it, for example:

- Describe the process of transcription or translation, respectively.
- Describe the involvement of the different types of RNA in protein synthesis.

3.10 PRACTICE QUESTIONS on DNA REPLICATION and TRANSCRIPTION

Question 4: DNA Replication and Transcription

4.1 Complete the following table that shows the differences between DNA replication and Transcription.

	DNA REPLICATION	TRANSCRIPTION
Template (how many)	2	1
Product that is formed	DNA	mRNA
Bases pairs that are formed	G-C and T-A	None

4.2 Underline the correct answer.

STATEMENT/QUESTION	ANSWER A	ANSWER B
mRNA is synthesised during _____	translation	<u>transcription</u>
mRNA has a/an _____	<u>codon</u>	anticodon
tRNA has a/an _____	codon	<u>anticodon</u>
One amino acid is equal to _____ codon(s)	<u>1</u>	3
tRNA carries the amino acids to the _____	<u>ribosome</u>	nucleus
tRNA picks up the amino acids during _____	<u>translation</u>	transcription
A polypeptide is a sequence of _____	<u>amino acids</u>	proteins
Which process is taking place at the ribosomes?	<u>translation</u>	transcription

4.3 The diagram below shows part of a mRNA (messenger RNA) molecule:

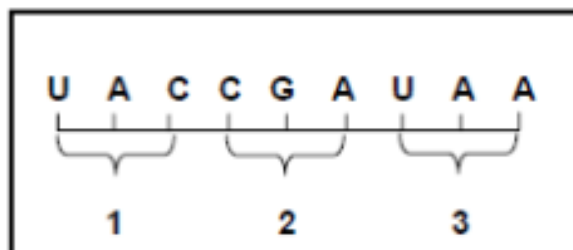

Key **cell organelles** involve in DNA synthesis:
 Nucleus
 Ribosome
 Key **molecules** involve in DNA synthesis
 DNA
 mRNA
 tRNA

- (a) How many codons are shown in the diagram? 3✓
- (b) Write the complementary base sequence of the DNA strand that formed codon 1 of the mRNA strand in the above diagram. ATG✓
- (c) Explain the purpose of a specific sequence of codons in a mRNA molecule. A codon codes for a specific amino acid✓, and this sequence of codons codes for a protein✓.

3.11 GENETIC CODING – EXAM TIPS/TECHNIQUES/NOTES

WHAT IS GENETIC CODING? The genetic code is the instructions (sequence of the DNA or mRNA nucleotides) in a gene that tell the cell how to make a specific protein.

Remember: Proteins are very important organic molecules because it does most of the work in cells and are required for the structure, function, and regulation of the body's tissues and organs.

How does Genetic coding occur?

DNA nucleotides = Base Triplets
mRNA nucleotides = Codons

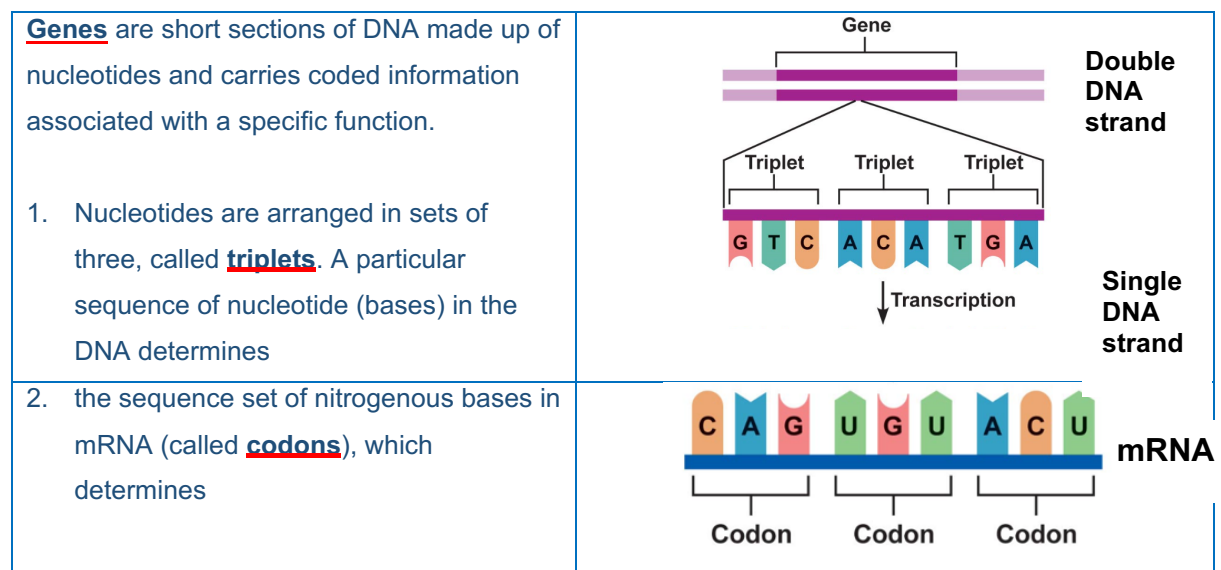

3. the order in which the sets on the tRNA (called **ANTI-CODONS**) gets attached to mRNA, which determines

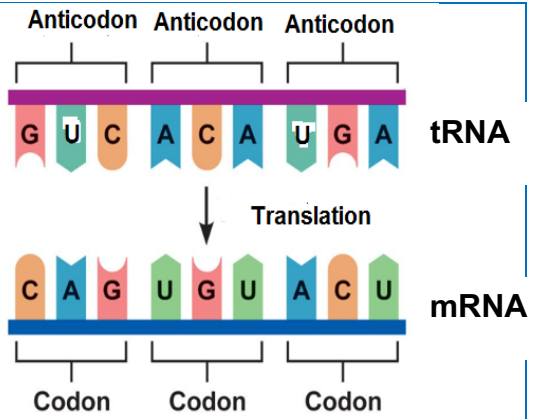

4. the sequence in which **amino acids** appear in a protein molecule, this determines



5. the type of **protein** formed

3.12 THE EFFECT OF MUTATION ON PROTEIN STRUCTURE (DNA SEQUENCE) – EXAM TIPS/TECHNIQUES/NOTES

Cell processes that copy genetic material are usually accurate to ensure genetic continuity in both new cells and offspring but, **mistakes/changes (mutation)** in the DNA can occur

<ul style="list-style-type: none"> Changes in the DNA sequence is referred to as gene mutations A gene mutation affects the type/arrangement of a single/a few nitrogen bases. this changes the sequence/order of the nitrogen bases/the code on the DNA and the RNA. <div style="border: 1px solid black; padding: 5px; margin-left: 600px; color: red;"> <p>Note: A mutation will NOT always lead to a formation of a different protein</p> </div>																																									
<ul style="list-style-type: none"> the same amino acid may be coded for, which causes no change in the amino acid sequence in the protein leading to the formation of the same protein 	<ul style="list-style-type: none"> a different amino acid may be coded for, which causes a change in the amino acid sequence in the protein leading to the formation of a different protein /alternate form of the required protein 																																								
<p style="text-align: center;"><u>CASE SCENARIO 1</u></p> <p>The table below shows some mRNA codons and the corresponding amino acids.</p> <table border="1" style="width: 100%; border-collapse: collapse;"> <thead> <tr> <th style="text-align: center;">mRNA CODONS</th> <th style="text-align: center;">AMINO ACID</th> </tr> </thead> <tbody> <tr><td style="text-align: center;">AGC</td><td style="text-align: center;">Serine</td></tr> <tr><td style="text-align: center;">GAU</td><td style="text-align: center;">Aspartate</td></tr> <tr><td style="text-align: center;">CUA</td><td style="text-align: center;">Leucine</td></tr> <tr><td style="text-align: center;">UAU</td><td style="text-align: center;">Tyrosine</td></tr> <tr><td style="text-align: center;">UUC</td><td style="text-align: center;">Phenylalanine</td></tr> <tr><td style="text-align: center;">AGU</td><td style="text-align: center;">Serine</td></tr> <tr><td style="text-align: center;">GAC</td><td style="text-align: center;">Aspartate</td></tr> <tr><td style="text-align: center;">UUU</td><td style="text-align: center;">Phenylalanine</td></tr> <tr><td style="text-align: center;">CUC</td><td style="text-align: center;">Leucine</td></tr> <tr><td style="text-align: center;">GAG</td><td style="text-align: center;">Glutamic acid</td></tr> </tbody> </table> <p>A section of mRNA has the following base sequence and is read from left to right:</p> <p style="text-align: center;">GAU CUC GAC AGC AUG ACC</p> <p>A mutation occurred which resulted in the following base sequence on the mRNA molecule:</p> <p style="text-align: center;">GAU CUC GAC AGU AUG ACC</p>	mRNA CODONS	AMINO ACID	AGC	Serine	GAU	Aspartate	CUA	Leucine	UAU	Tyrosine	UUC	Phenylalanine	AGU	Serine	GAC	Aspartate	UUU	Phenylalanine	CUC	Leucine	GAG	Glutamic acid	<p style="text-align: center;"><u>CASE SCENARIO 2</u></p> <p>The table below shows the RNA codons that code for different amino acids.</p> <table border="1" style="width: 100%; border-collapse: collapse;"> <thead> <tr> <th style="text-align: center;">CODON</th> <th style="text-align: center;">AMINO ACID</th> </tr> </thead> <tbody> <tr><td style="text-align: center;">UUC</td><td style="text-align: center;">Phenylalanine</td></tr> <tr><td style="text-align: center;">AUC</td><td style="text-align: center;">Isoleucine</td></tr> <tr><td style="text-align: center;">AAU</td><td style="text-align: center;">Asparagine</td></tr> <tr><td style="text-align: center;">GAA</td><td style="text-align: center;">Glutamic acid</td></tr> <tr><td style="text-align: center;">GUA</td><td style="text-align: center;">Valine</td></tr> <tr><td style="text-align: center;">CAG</td><td style="text-align: center;">Glutamine</td></tr> <tr><td style="text-align: center;">CAU</td><td style="text-align: center;">Histidine</td></tr> <tr><td style="text-align: center;">GGA</td><td style="text-align: center;">Glycine</td></tr> </tbody> </table> <p>The DNA base triplets 1, 2 and 3 below is read from left to right:</p> <p style="text-align: center;">GTC AAG CCT</p> <p>A mutation occurred which resulted in the following base sequence on the DNA molecule:</p> <p style="text-align: center;">GTC TAG CCT</p>	CODON	AMINO ACID	UUC	Phenylalanine	AUC	Isoleucine	AAU	Asparagine	GAA	Glutamic acid	GUA	Valine	CAG	Glutamine	CAU	Histidine	GGA	Glycine
mRNA CODONS	AMINO ACID																																								
AGC	Serine																																								
GAU	Aspartate																																								
CUA	Leucine																																								
UAU	Tyrosine																																								
UUC	Phenylalanine																																								
AGU	Serine																																								
GAC	Aspartate																																								
UUU	Phenylalanine																																								
CUC	Leucine																																								
GAG	Glutamic acid																																								
CODON	AMINO ACID																																								
UUC	Phenylalanine																																								
AUC	Isoleucine																																								
AAU	Asparagine																																								
GAA	Glutamic acid																																								
GUA	Valine																																								
CAG	Glutamine																																								
CAU	Histidine																																								
GGA	Glycine																																								
<p>Question 1: <u>Describe the mutation</u> that occurred.</p>	<p>Question 1: <u>Describe the mutation</u> that occurred.</p>																																								

<p>Steps: Compare the original mRNA to the one that has undergone mutation.</p> <ol style="list-style-type: none"> 1. Identify the affected codon or nucleotide 2. Describe which nucleotide has been replaced/deleted <p>Answer: C was replaced by U on the 4th codon/AGC</p>	<p>Steps: Compare the original DNA base triplets to the one that has undergone mutation</p> <ol style="list-style-type: none"> 1. Identify the affected DNA Base triplet and nucleotide 2. Describe which nucleotide has been replaced/deleted <p>Answer: In DNA base triplet 2 the first adenine was replaced by T.</p>
<p>Question 2: Explain <u>the effect that the mutation will have</u> on the resulting protein.</p> <p>Steps: Use the given table to find out if the new codon formed after the mutation codes for the same or a different amino acid.</p> <ol style="list-style-type: none"> 1. The affected codon (AGC) in the original RNA codes for the Amino acid SERINE 2. The codon that has undergone mutation (AGU) also codes for the same Amino acid SERINE <p>Answer: It codes for the same amino acid/serine The amino acid sequence <u>will not change</u> Therefore there will be no effect/same protein formed</p>	<p>Question: Explain how this <u>mutation will affect</u> the protein that will be formed.</p> <p>Steps: Use the given table to find out if the new codon formed after the mutation codes for the same or a different amino acid.</p> <ol style="list-style-type: none"> 1. Convert the DNA triplet of bases (AAG) to the mRNA codon (UUC) and (TAG) to the mRNA codon (AUC) before you could read off from the table. 2. The codon (UCC) codes for the amino acid PHENYLALANINE 3. The codon (AUC) codes for a different amino acid ISOLEUCINE <p>Answer: A different amino acid (isoleucine) will be coded for instead of phenylalanine The amino acid sequence <u>will change</u> Therefore, a different protein may form</p>

3.13 PRACTICE QUESTIONS on MUTATION AND PROTEIN STRUCTURE

Question 4: Mutation and Protein structure

4.1 Study the diagram below and complete:

- Strand 1 and 2,
- Anticodons on the tRNA and
- The corresponding amino acids by making use of all the information provided.

Note that mRNA was formed on strand 2.

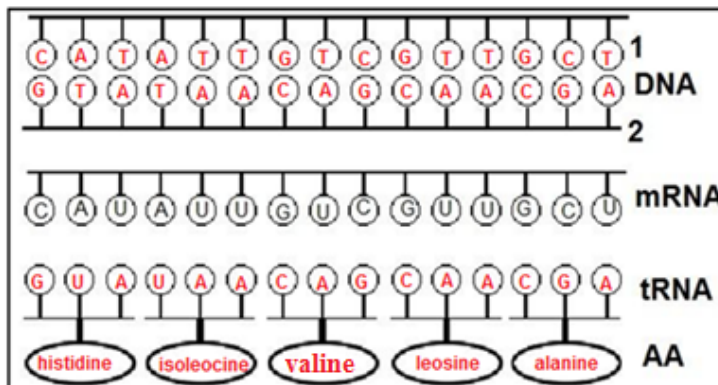

mRNA	Amino acid
CAU	histidine
AUU	isoleucine
GUC	valine
GUU	leucine
GCU	alanine

Key for amino acids (AA stands for amino acids)

4.2 The diagram below represents a part of protein synthesis.

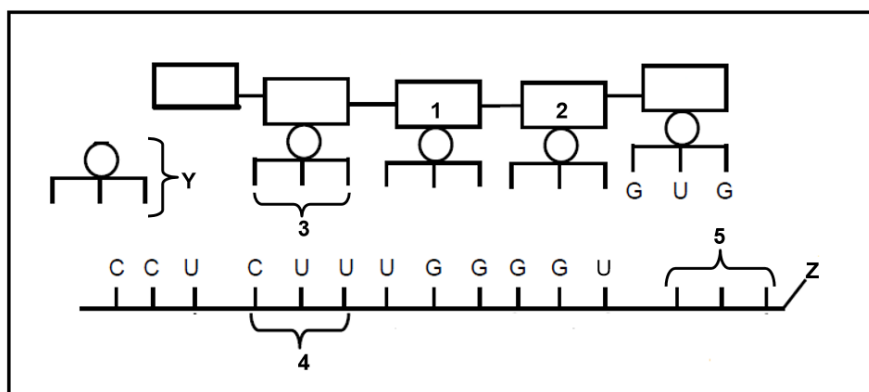

(a) Identify the molecules labelled Y and Z.

Y - tRNA✓

Z - mRNA✓

(b) Name the phase of protein synthesis represented in the diagram.

Translation✓

(c) Give the name of the group of three bases that are indicated by number 4 on the diagram. Codon ✓

(d) Write down the base codes (from left to right) that would be found at point 3 on the diagram. GAA✓

(e) The table below shows the DNA base triplets that code for the different amino acids.

Amino acid	Base triplet in DNA template
Lys (lysine)	TTT
Ala (alanine)	CGA, GCG
Thr (threonine)	ACC
Pro (proline)	ACA, CCA
Trp (tryptophan)	ACT
Val (Valine)	GTG
Gly (glycine)	TGA, GGC

Write down the names of the amino acids represented by 1 and 5.

Note: Use the following method to solve similar questions

1. Base triplet in DNA template	2. Codon on mRNA	3. Anti-codon on tRNA	4. Specific Amino acid
GTG	CAC	GUG	Valine

1 – threonine✓

5 - valine✓

4.3 The diagram below illustrates protein synthesis.

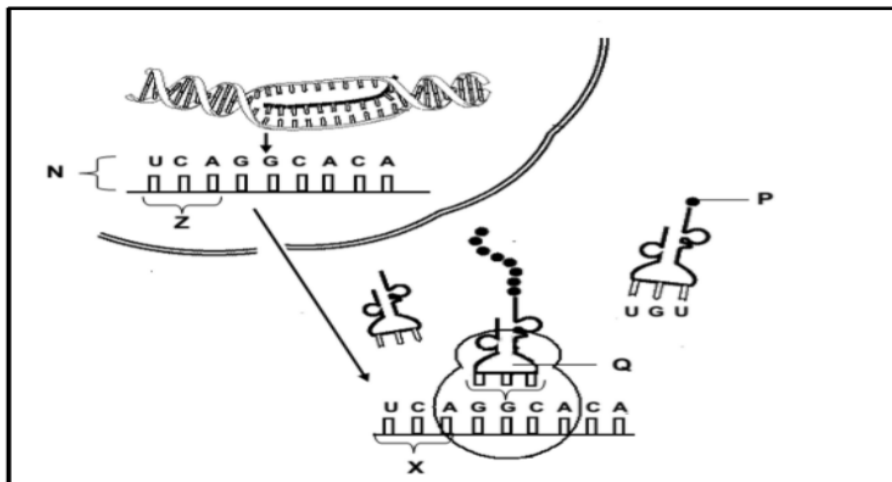

- (a) Name the molecule represented by N. mRNA ✓
- (b) Write down the sequence of the FIRST THREE nitrogenous bases on the DNA strand that led to the formation of Z. AGT ✓
- (c) The table below shows the base triplets of DNA and the amino acid each code for.

Base triplet of DNA	Amino acid coded for amino acid
AGT	Serine
CCG	Glycine
TGT	Threonine
GTA	Histidine
CAA	Valine
TCC	Arginine
ACA	Cysteine

With reference to the diagram in QUESTION 5.3 and the table above:

- (i) State the anticodon in molecule Q. CCG ✓
- (ii) Name the amino acid labelled P. Threonine ✓

Note: Use the following method to solve similar questions

1. Base triplet in DNA template	2. Codon on mRNA	3. Anti-codon on tRNA	4. Specific Amino acid
TGT	ACA	UGU	Threonine

(e) Describe how the composition of the protein molecule changes if the base sequence at X is UGU instead of UCA.

Serine will be replaced by Cysteine✓ and may lead to the formation of a different protein✓

3.14 TYPICAL EXAM QUESTIONS

Question 1: DNA REPLICATION – *Various sources*

1.1 Various options are provided as possible answers to the following questions. Choose the correct answer.

1.1.1 The phase in which DNA replication takes place is called ...

- A Prophase.
- B Interphase.
- C Metaphase.
- D Anaphase.

1.1.2 The list below provides information relating to the replication of DNA:

1. Complementary nucleotides bind to each of the two strands.
2. Sugar phosphate bonds form between the nucleotides.
3. The newly formed DNA molecules are identical to each other.
4. After unwinding, the DNA molecule forms two single strands.

The correct order of these events as they occur in DNA replication is ...

- A 1, 2, 3 and 4.
- B 1, 2, 3 and 2.
- C 4, 2, 1 and 3.
- D 4, 1, 2 and 3.

1.1.3 The diagram shows the outcomes from four different models of DNA reproduction after one nuclear division. The parent DNA is shown in black, and the newly synthesized DNA is shown in grey

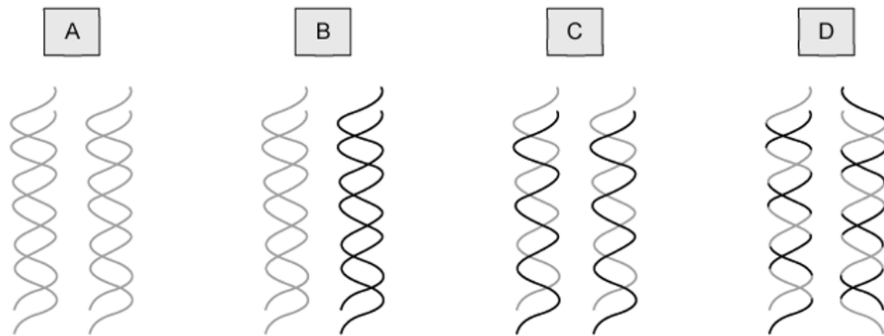

Which diagram shows traditional DNA replication?

(2 x 3) (6)

(DBE, Feb/Mar. 2015, Paper 2); (MP, Sep 2018, Paper 2)

1.2 The diagram below represents DNA replication.

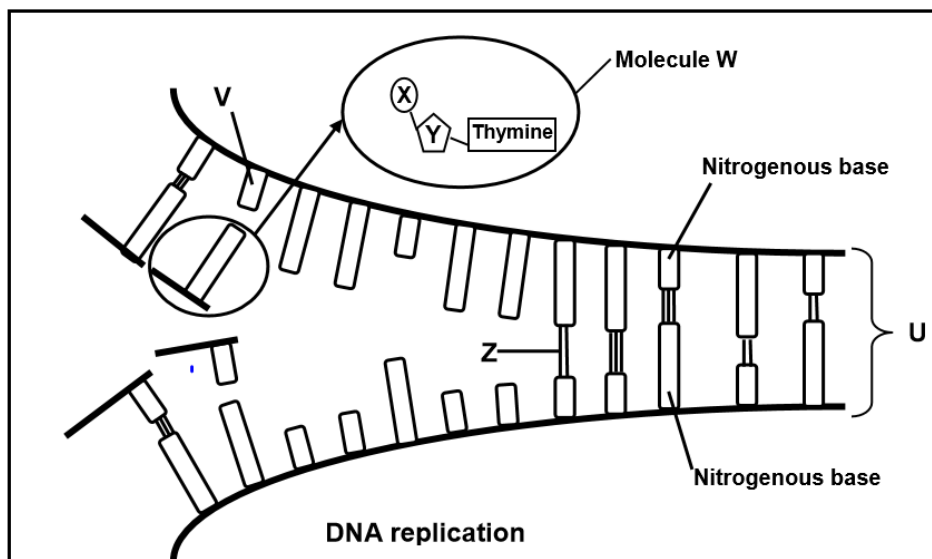

1.2.1 Identify the following:

- (a) Molecules W and U (2)
- (b) Parts of molecule W labelled X and Y (2)
- (c) Bond Z (1)
- (d) Nitrogenous base V (1)

- 1.2.2 Where in the cell does this process take place? (1)
- 1.2.3 Name the phase of the cell cycle where replication takes place. (1)
- 1.2.4 Which proteins control this process? (1)
- 1.2.5 Give ONE biological importance of this process (1)
- 1.2.6 Describe how this process takes place. (5)
- 1.2.7 Describe how an error in **DNA replication** may lead to a **gene mutation**. (2)

Question 2: PROTEIN SYNTHESIS and MUTATION - DBE, Nov. 2019, Paper 2

- 2.1 Various options are provided as possible answers to the following questions. Choose the correct answer.

The diagram below showing part of a DNA molecule before and after a mutation.

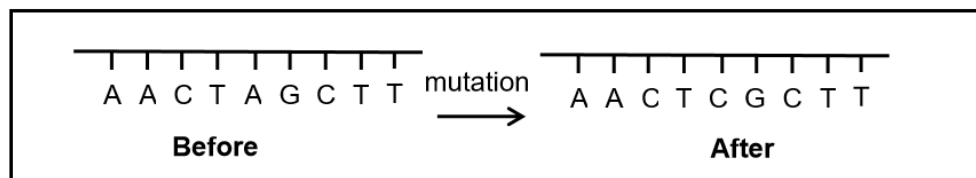

- 2.1.1 The mutation ...
- A. will result in an extra chromosome.
 - B. will produce the same protein if a different amino acid is coded for.
 - C. will produce a different protein if a different amino acid is coded for.
 - D. is the result of an extra chromosome.
- 2.1.2 Which ONE of the following best describes the mutation?
- A. More than one nitrogenous base was changed.
 - B. Adenine was changed to cytosine.
 - C. Adenine was changed to thymine.
 - D. Cytosine was changed to adenine.

(2 x 2) (4)

FS, Sep. 2019, Paper 2

2.2 The following sequence represents three m-RNA codons.

AGA AUA GGA

The table below shows the amino acids that correspond with different DNA-triplets.

AMINO ACID	DNA CODE
Isoleucine	TAA
Glycine	CCT
Isoleucine	TAT
Arginine	TCT

2.2.1 Write down the correct sequence of amino acids for the three m-RNA codons from left to right. (2)

2.2.2 A mutation caused codon **AUA** to change to **AUU**. Describe how this mutation will influence the formation of the protein. (3)

DBE, Jun 2017, Paper 2

2.3 A species of bacteria contains a type of protein, called protein 1. A mutation occurred which resulted in the formation of a second type of protein called protein 2, instead of protein 1.

Scientists determined the amino acid sequence of each protein. They then used the amino acid sequence to find the DNA base sequences that coded for portions of these proteins.

The results are shown in the tables below.

PORTION OF PROTEIN 1				
AMINO ACID SEQUENCE	Lysine	Serine	Proline	Cysteine
DNA BASE SEQUENCE	TTT	TCA	GGT	ACG

PORTION OF PROTEIN 2				
AMINO ACID SEQUENCE	Lysine	Serine	Proline	Tryptophan
DNA BASE SEQUENCE	TTT	TCA	GGT	ACC

2.3.1 Give the:

- (a) DNA triplet for the third amino acid from the left in the sequence for protein 2 (1)
- (b) Codon for lysine (1)
- (c) Anticodon for serine (1)

2.3.2 Protein 1 is made up of 66 amino acids.

How many of EACH of the following is involved in the formation of this protein?

- (a) Genes (1)
- (b) RNA nucleotides (1)
- (c) Codons (1)

2.3.3 Describe how the mutation caused a change in the structure of the protein. (4)

Question 3 - DNA PROFILING - (DBE, Nov. 2019 & 2020, Paper 2)

3.1 Detectives were investigating a crime scene and found blood on a broken window. They suspected that the blood was that of the criminal. To identify the criminal, they analysed a DNA sample from the blood and compared it to that of four suspects.

The diagram below was produced:

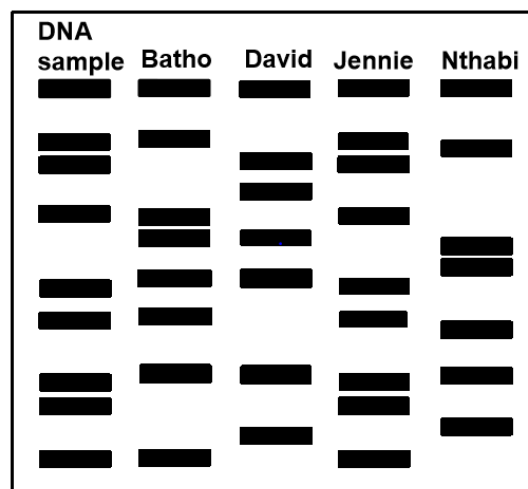

- 3.1.1 Name the technique that was used to identify the criminal. (1)
- 3.1.2 Who is the possible criminal? (1)
- 3.1.3 Explain your answer to QUESTION (b) (2)
- 3.1.4 State ONE other use of the technique identified in QUESTION (a) (1)
- 3.1.5 Sometimes the paternity of a son or a daughter is disputed.
Describe how DNA profiling are used in paternity testing. (5)

Question 4 - PROTEIN SYNTHESIS - (NW, Sep. 2018, Paper 2)

4.1 The diagram below shows the process of protein synthesis.

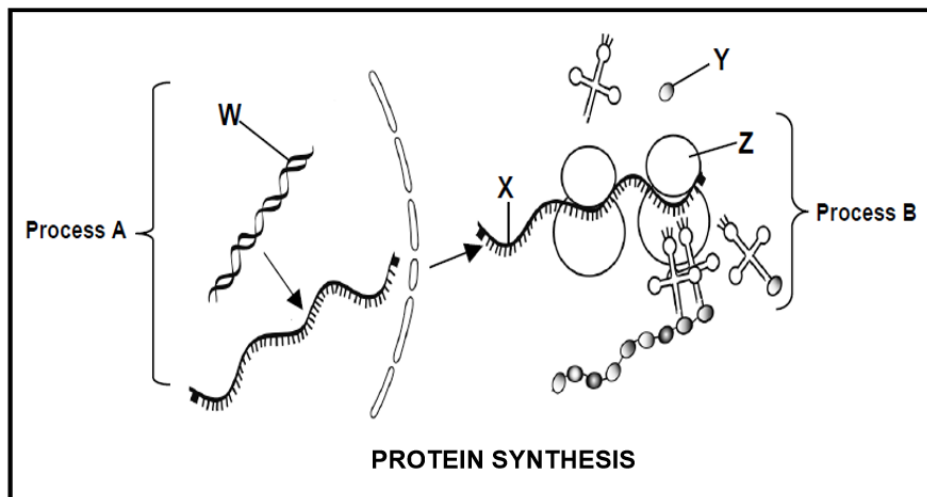

- 4.1.1 Name the part of the protein synthesis indicated by process A. (1)
- 4.1.2 Identify:
 (a) Molecule **X** (1)
 (b) Molecule **Y** (1)
 (c) Organelle **Z** (1)
- 4.1.3 Describe the role of molecule **W** during process **A**. (4)
- 4.1.4 Name AND describe process **B**, which takes place at organelle **Z**. (3)
- 4.1.5 Name the type of bond that joins two amino acids together. (1)
- 4.1.6 The table below shows the triplets of bases on a template of DNA for some amino acids.

AMINO ACIDS		DNA TRIPLETS
Glutamic acid	(glu)	CTT CTC
Histidine	(his)	GTA GTC
Leucine	(leu)	GAA GAG GAT GAC
Proline	(pro)	GGA GGG GGT GGC
Threonine	(thr)	TGA TGG TGT TGC
Valine	(val)	CAA CAG CAT CAC

The diagram below shows the base sequence in DNA and mRNA for the first seven amino acids in a polypeptide of haemoglobin.

DNA

CAC	A	GAC	TGA	GGA	CTC	E
-----	----------	-----	-----	-----	-----	----------

mRNA

GUG	CAG	CUG	B	CCU	GAG	GAG
-----	-----	-----	----------	-----	-----	-----

Polypeptide chain of haemoglobin

val	his	C	thr	pro	glu	D
-----	-----	----------	-----	-----	-----	----------

Use the table to determine:

- (a) A (1)
- (b) B (1)
- (c) C (1)
- (d) D (1)

- 4.1.7 Explain how a change in a single base of the sixth DNA triplet may lead to the production of a different protein. (2)

4.2 The diagram below represents two stages of protein synthesis.

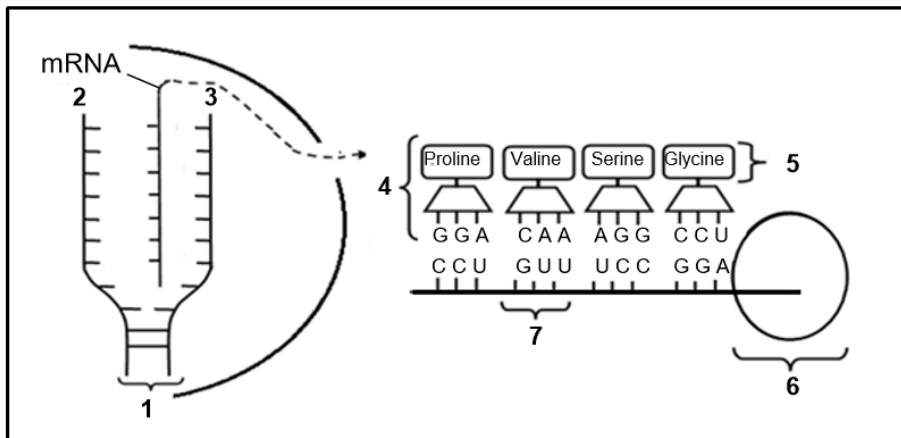

4.2.1 Provide labels for:

- (a) Molecule 1 (1)
- (b) Organelle 6 (1)

4.2.2 Give only the NUMBER of the part which represents a:

- (a) DNA template strand (1)
- (b) Monomer of proteins (1)
- (c) Codon (1)

4.2.3 Describe translation as it occurs at organelle 6. (4)

4.2.4 Provide the:

- (a) DNA sequence that codes for glycine (2)
- (b) Codon for proline (2)

4.2.5 State TWO differences between a DNA nucleotide and an RNA nucleotide. (4)

4.3 The diagram below shows part of a process involved in the production of a protein.

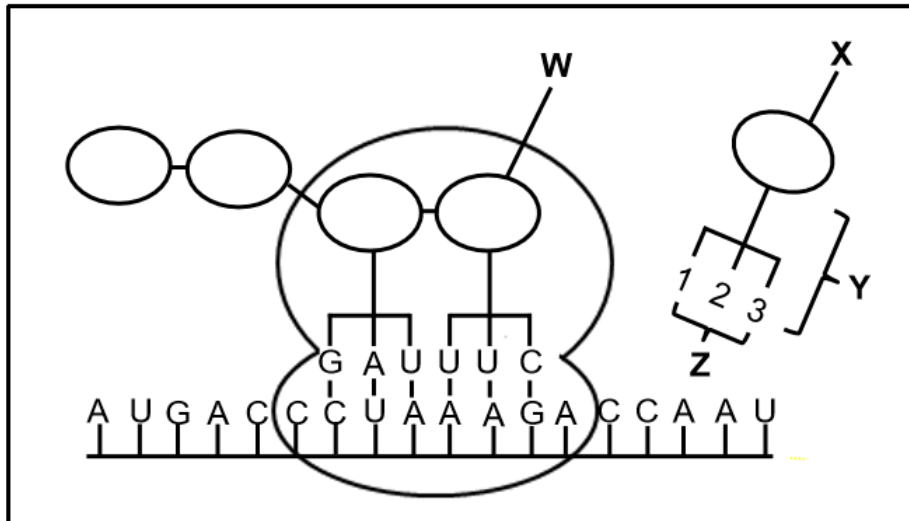

4.3.1 Identify:

- (a) Molecule Y (1)
- (b) The group of nitrogenous bases Z (1)

4.3.2 If X is the next amino acid required after W, then identify:

- (a) Nitrogenous bases 1, 2 and 3 (2)
- (b) The DNA base triplet that codes for X (2)

4.3.3 Describe the process of transcription. (6)

3.15 SOLUTIONS TO DNA PRACTICE QUESTIONS

Question 1

- 1.1.1 B✓✓ (2)
- 1.1.2 C✓✓ (2)
- 1.1.3 C✓✓ (2)
- 1.2.1 (a) W – Nucleotide✓ U – DNA✓ (2)
- (b) X – Phosphate✓/phosphate ion
Y – Deoxyribose✓sugar (2)
- (c) Z – Hydrogen✓ bond (1)
- (d) V – Adenine✓ (1)
- 1.2.2 Nucleus✓ (1)
- 1.2.3 Interphase✓ (1)
- 1.2.4 Enzymes✓ (1)
- 1.2.5 - DNA replication ensures that daughter cells in mitosis will have identical genetic make up as the parent cell✓
- ensures that the number of chromosomes in each daughter cell is the same as the parent cell✓
- ensures that genetic properties are transmitted from one generation to the next✓
Any 1 (1)
- 1.2.6 - DNA unwinds✓ from one end to appear as a ladder✓
- the weak hydrogen bonds✓ between the nitrogen bases break
- and the two single strands move apart✓
- each nucleotides picks up free nucleotides✓ from the nucleoplasm
- and become double again✓
- the two new double strands are identical✓ to each other and the original
- each double strand now become twisted helical structure✓
- the process is controlled by enzymes✓ Any 5 (5)

- 1.2.7 - If the incorrect nitrogen base✓ attaches to the original strand/if a nitrogen base is added or deleted
 - the sequence✓/order of the bases changes on the new DNA molecule
 - resulting in a change in the gene structure✓ (Any 2) (2)

Question 2

2.1.1 C✓✓ (2)

2.1.2 B✓✓ (2)

2.2.1 Arginine, Isoleucine, Glycine✓✓ (2)

2.2.2 - The mutated codon AUU code for the same amino acid/Isoleucine.✓
 - The amino acid sequence will not change ✓
 - and will therefore code for the same protein.✓ (3)

2.3.1 (a) GGT✓ (1)

(b) AAA✓ (1)

(c) UCA✓ (1)

2.3.2 (a) 1✓ (1)

(b) 198✓ (1)

(c) 66✓ (1)

2.3.3 - One of the base triplets on the DNA has changed✓
 - from ACG to ACC✓
 - The triplet ACG codes for the amino acid cysteine✓
 - while the triplet ACC codes for the amino acid tryptophan✓
 - resulting in a change in the sequence✓ of amino acids Any 4 (4)

Question 3

- 3.1.1 DNA-profiling✓ (1)
- 3.1.2 Jennie✓ (1)
- 3.1.3 - Jennie's DNA profile✓/bands
- matches the DNA profile✓/bands of the sample form the crime scene (2)
- 3.1.4 - Proof of paternity✓
- Tracing missing persons✓
- Identification of genetic disorders✓
- Matching tissues for organ transplants✓
- Identifying dead persons✓ /animals (Any 1) (1)
- 3.1.5 - A child received DNA from both parents✓
- The DNA profiles of the mother, child and the possible father are determined✓
- A comparison of the DNA bands of the mother and the child is made✓
- The remaining DNA bands are compared to the possible father's DNA bands✓
- If all the remaining DNA bands in the child's profile match the possible father's DNA bands✓
- then the possible father is the biological father✓
- If all the remaining DNA bands in the child's profile does not match the possible father's DNA bands✓
- then the possible father is not the biological father✓ Any 5 (5)

Question 4

- 4.1.1 Transcription✓ (1)
- 4.1.2 (a) mRNA✓ (1)
(b) Amino acid✓ (1)
(c) Ribosome✓ (1)
- 4.1.3 - The double helix DNA unwinds ✓
- The double-stranded DNA molecule unzips✓/ weak hydrogen bonds break
- to form two separate strands✓
- One DNA strand is used as a template✓
- to form mRNA✓
- using free RNA nucleotides from the nucleoplasm✓
- The mRNA is complementary to the DNA✓ (Any 4) (4)

- 4.1.4 - In **B translation***✓ takes place ***Compulsory mark**
 - mRNA attaches to the ribosome✓
 - tRNA picks up amino acids ✓
 - brings it to the codons✓ of mRNA
 - the anticodon✓ determines which amino acid will bind to the tRNA
 1*+ Any 2 (3)
- 4.1.5 Peptide✓ bond (1)
- 4.1.6 (a) A- GTC✓ (1)
 (b) B- ACU✓ (1)
 (c) C- Leucine (leu)✓ (1)
 (d) D- Glutamic acid (glu)✓ (1)
- 4.1.7 - The codon of the mRNA alters✓
 - This will lead to a different tRNA✓ picking up a different amino acid. ✓
 (Any 2) (2)
- 4.2.1 (a) DNA✓ (1)
 (b) Ribosome✓ (1)
- 4.2.2 (a) 2✓ (1)
 (b) 5✓ (1)
 (c) 7✓ (1)
- 4.2.3 - The mRNA attaches to the ribosome✓
 - When each codon✓ of the mRNA
 - matches with the anticodon on the tRNA✓
 - the tRNA brings the required amino acid to the ribosome✓
 - When the different amino acids are brought in sequence✓
 - adjacent amino acids are linked by peptide bonds✓
 - to form the required protein✓/polypeptide (Any 4) (4)

- 4.2.4 (a) CCT✓✓ (2)
 (b) CCU✓✓ (2)

4.2.5

DNA	RNA
Has deoxyribose✓ sugar	Has ribose✓ sugar
Has nitrogen base thymine (T)✓/ A, C, G and T	Has nitrogen base uracil(U)✓/ A, C, G and U

(Mark first TWO only) (2 x 2) (4)
TABLE NOT REQUIRED

- 4.3.1 (a) tRNA✓/transfer RNA (1)
 (b) Anticodon✓ (1)

- 4.3.2 (a) UGG✓✓ (in correct order) (2)
 (b) TGG✓✓ (in correct order) (2)

- 4.3.3 - The double helix DNA unwinds✓ and
 - unzips✓/weak hydrogen bonds break
 - to form two separate strands✓
 - One strand is used as a template✓
 - to form mRNA✓
 - using free RNA nucleotides from the nucleoplasm✓
 - The mRNA is complementary to the DNA✓
 - The coded message for protein synthesis is thus copied onto mRNA✓

Any 6 (6)

4. MEIOSIS

TERM	1	PAPER	2
DURATION	8 hours (2 weeks)	WEIGHTING	21 marks (14%)
LINKS TO PRIOR-KNOWLEDGE/BACKGROUND KNOWLEDGE			
Mitosis, Chromosomes, DNA replication			
RESOURCES			
Textbooks, Study Guides, MTG, Past NSC, SC & Provincial Question Papers			

4.1 MINDMAP on MEIOSIS

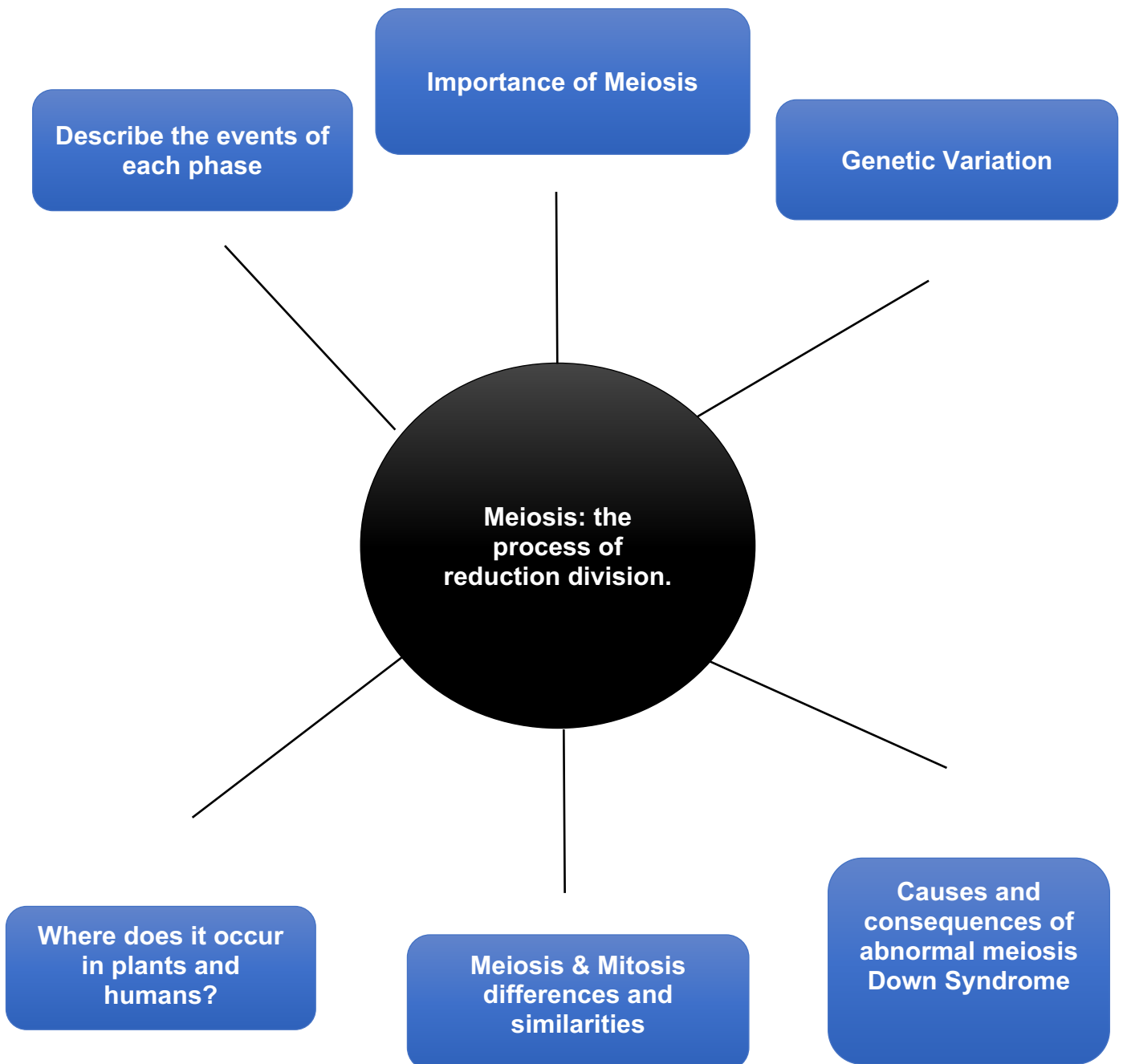

4.2 LINKS TO PRIOR-KNOWLEDGE/BACKGROUND KNOWLEDGE

The process of mitosis - Mitosis is made up of two major divisions: **nuclear division (Karyokinesis)** and **cytoplasm division (Cytokinesis)**.

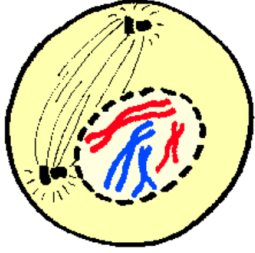
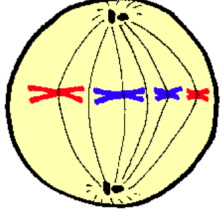
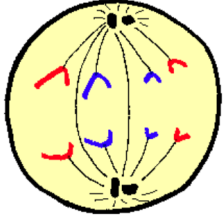
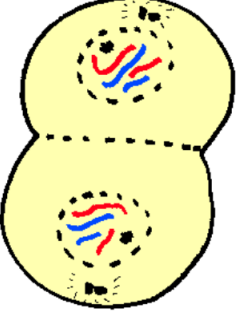
PHASES	DIAGRAM
<p>PROPHASE</p> <ul style="list-style-type: none"> • Cell is ready for division. • Nuclear membrane starts to disintegrate. • Nucleolus disappears • Replicated chromosomes become visible • Spindle fibres are formed from the centrosomes. • Centrioles move towards the opposite poles. Centrosomes only found in the animal cell. 	
<p>METAPHASE</p> <ul style="list-style-type: none"> • Nuclear membrane has disintegrated. • Replicated chromosomes line up on the equator. • Spindle fibre attaches on the centromere of each replicated chromosome. 	
<p>ANAPHASE</p> <ul style="list-style-type: none"> • Centromere of each replicated chromosome splits to form two unreplicated chromosomes. • Unreplicated chromosomes from each chromosome are pulled to the opposite poles 	
<p>TELOPHASE</p> <ul style="list-style-type: none"> • Cytokinesis starts by the cell membrane which constricts at the equator. • Nuclear membrane and nucleolus appear in each daughter cell. • Each daughter cell has the same number of unreplicated chromosomes as the parent. 	

NOTE: Before the process of mitosis starts, DNA replication first occur during Interphase. After DNA replication the chromatin network in the nucleus becomes visible as chromosomes.

The significance of DNA replication for mitosis:

- To double the genetic material
- Each daughter cell receives the same amount of DNA
- To ensure genetically identical daughter cells

4.3 DIFFERENTIATE BETWEEN RELATED TERMINOLOGIES

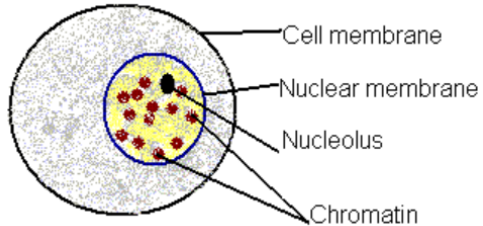
NUCLEAR MEMBRANE	 <p>Cell membrane Nuclear membrane Nucleolus Chromatin</p>
<p>The nuclear membrane is the membrane which surrounds the nucleus, enclosing the genetic material.</p>	
CELL MEMBRANE	
<p>The cell membrane is the membrane that separates the interior of all cells from the outside environment</p>	

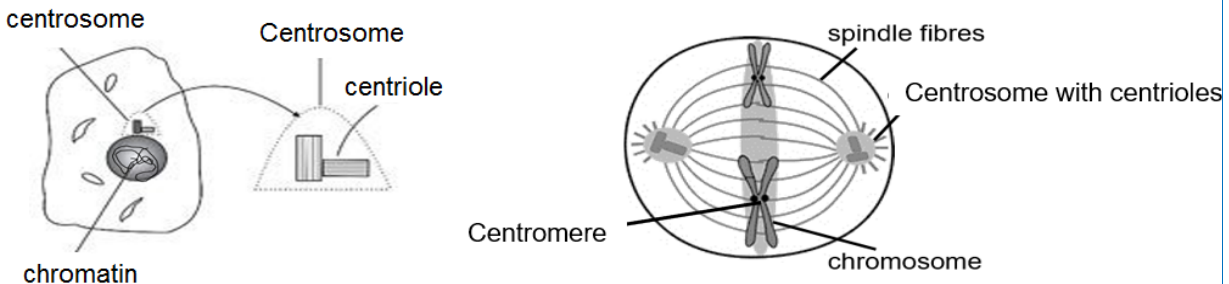
CENTROSOME	CENTRIOLE	CENTROMERE
<p>Organelle (containing two centrioles) found only in animal cells. This structure is responsible for the formation of spindle fibres during cell division in animal cells.</p>	<p>structures formed when the centrosome divides into two; they move to opposite ends of the cell during cell division</p>	<p>The centromere is not a structure as such but a site where two chromatids are held together in a replicated chromosome and also where the chromosome is attached to the spindle thread during cell division.</p>
 <p>centrosome Centrosome centriole chromatin spindle fibres Centrosome with centrioles Centromere chromosome</p>		

CHROMATIN NETWORK	CHROMOSOME	CHROMATID
The form in which chromosomes are found in the nucleus of a cell that is not dividing. The chromatin network consists of a mass of long, tangled threads of DNA	A chromosome is the condensed form of a chromatin. A threadlike structure made up of DNA and protein found in the nucleus of most living cells, carrying genetic information in the form of genes	This refers to each of the two threads of a replicated chromosome. In other words, a chromosome is composed of two chromatids.

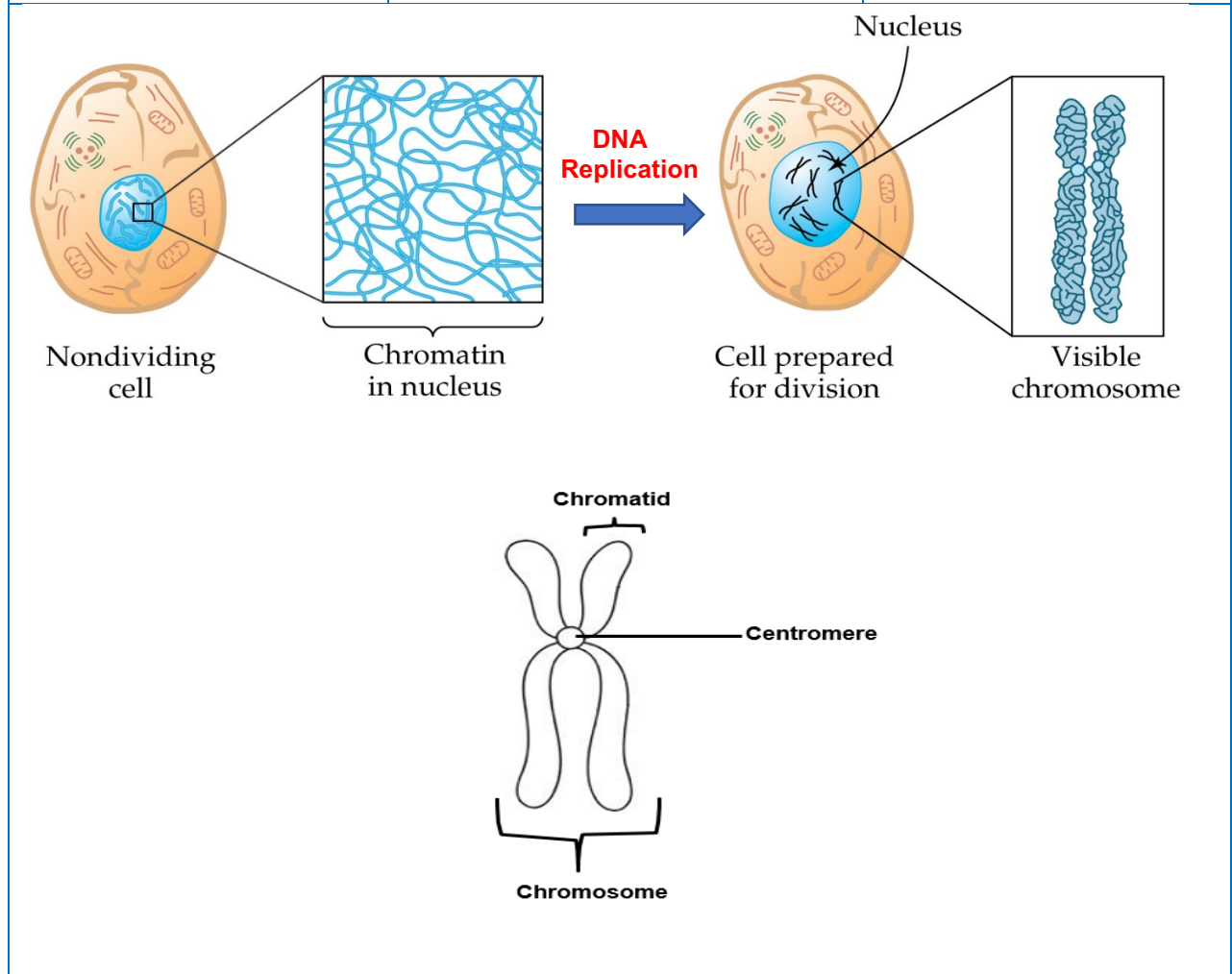

Gamete (sex cell) - cells formed by meiosis in male testis and female ovaries which contain half the chromosome number.	Somatic cell - Body cells that contain the full set of chromosomes, 23 inherited from each parent (46 in total).
HAPLOID (N)	DIPLOID (2N)
Haploid cells only have <u>one set of chromosomes</u> . Chromosomes in haploid cells have no homologous partners.	Diploid cells have <u>two sets of chromosomes</u> , where each chromosome has a homologous partner.

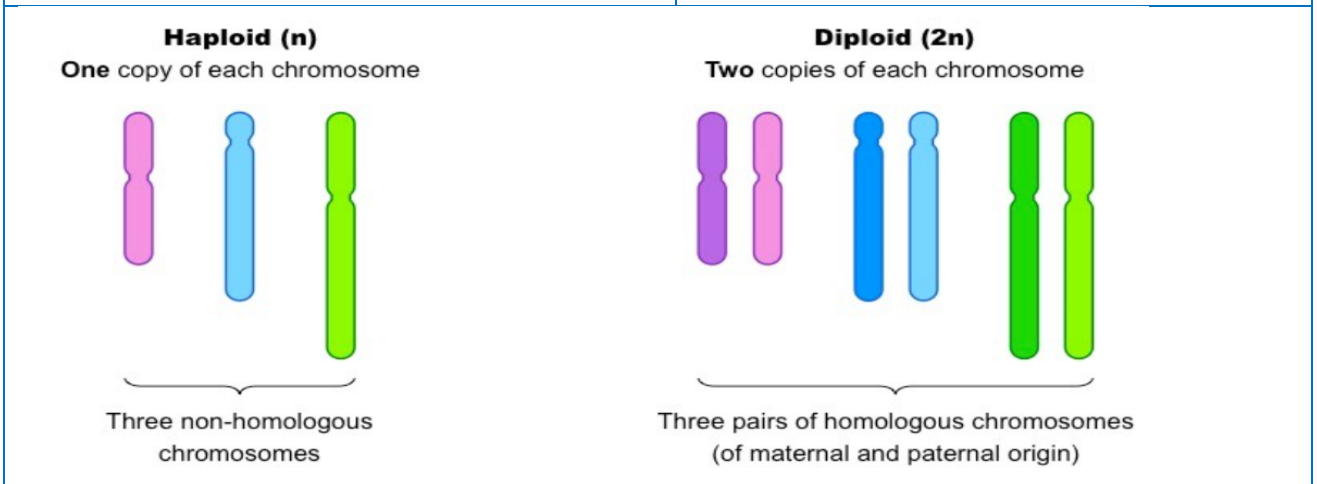

Karyotype - A diagram that shows the number, size and arrangement of chromosomes within a somatic cell or sex cell	
AUTOSOMES	GONOSOMES (SEX CHROMOSOMES)
The first 22 pairs of chromosomes in a human somatic cell which control the appearance, structure and functioning of the body and is not connected with the determination of sex.	The last pair of chromosomes in a human somatic cell (XX or XY) responsible for sex determination

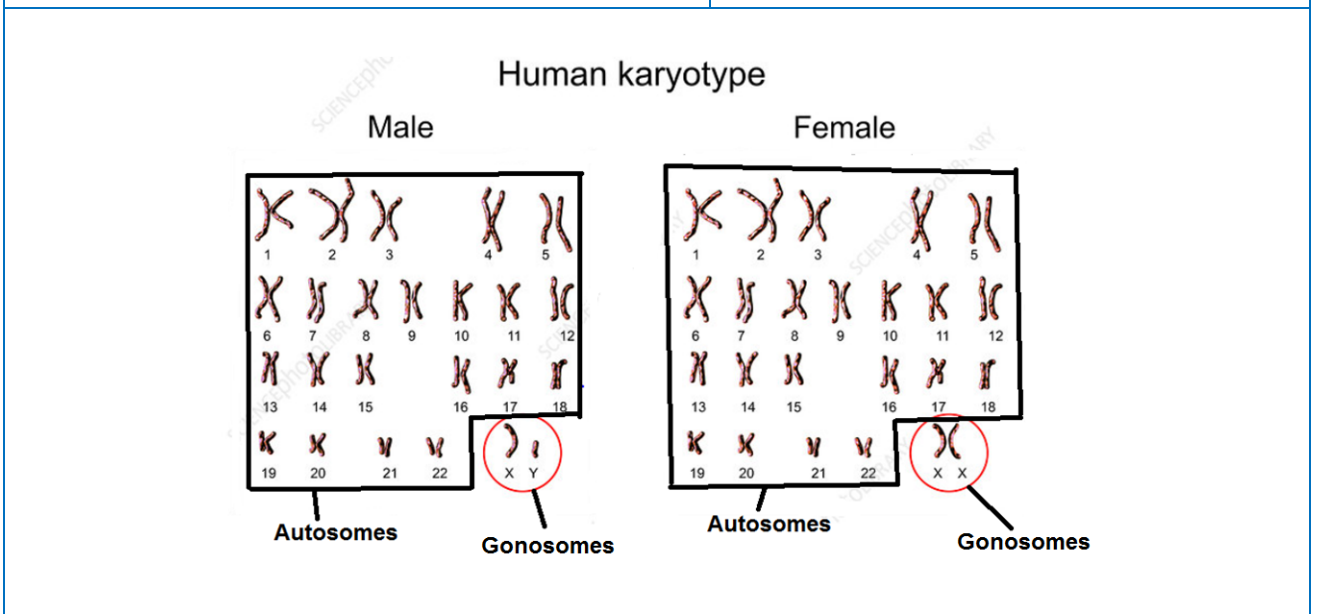

HOMOLOGOUS CHROMOSOMES	BIVALENT
<p>Chromosomes that are identical in shape and size and which contain genes for the same set of characteristics.</p>	<p>The term "bivalent" refers to a pair of homologous chromosomes which lie side by side just before crossing over. At this stage they function as one unit.</p> <p>Bivalent refers to homologous chromosomes at a particular stage; not all homologous chromosomes are bivalent. Homologous chromosomes may be scattered in the nucleoplasm, singly.</p> <p>After crossing over homologous chromosomes are no longer considered as a bivalent, but are, nevertheless still homologous chromosomes.</p>

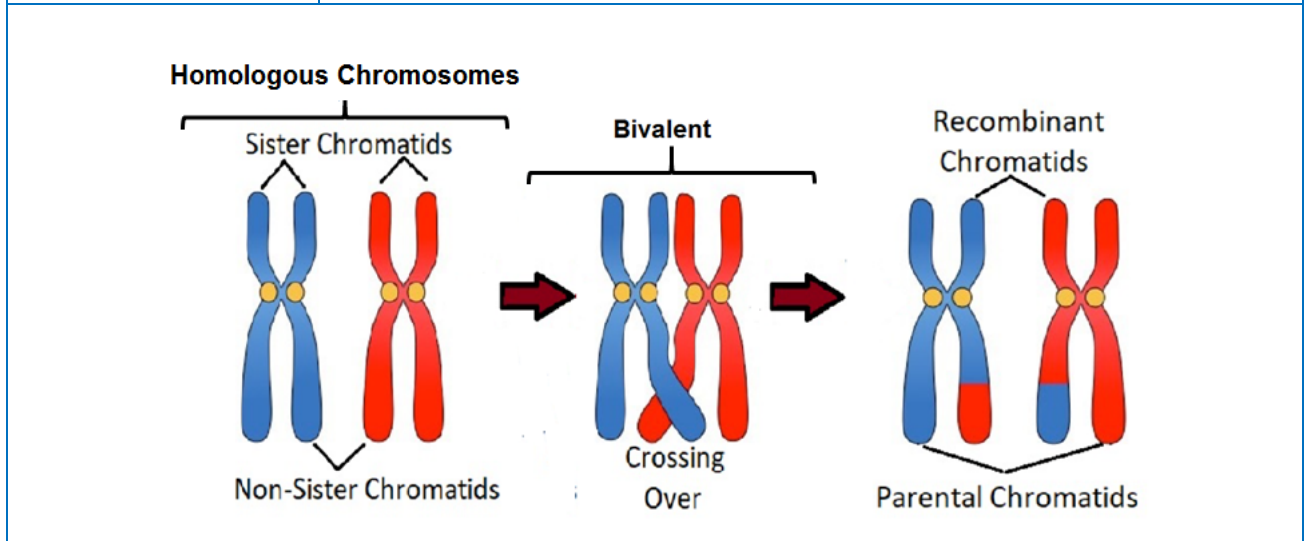

REPLICATED CHROMOSOME	UNREPLICATED CHROMOSOME
<p>This refers to a chromosome as it appears <u>after DNA replication</u></p> <p>Each chromatid consists of a DNA molecule which is made of <u>two DNA strands</u> joined together to form a ladder-like structure. Therefore, a replicated chromosome consists of <u>two DNA molecules NOT two DNA strands</u></p>	<p>This refers to a chromosome as it appears <u>before DNA replication</u> takes place.</p> <p>It has <u>one double stranded DNA molecule</u></p>

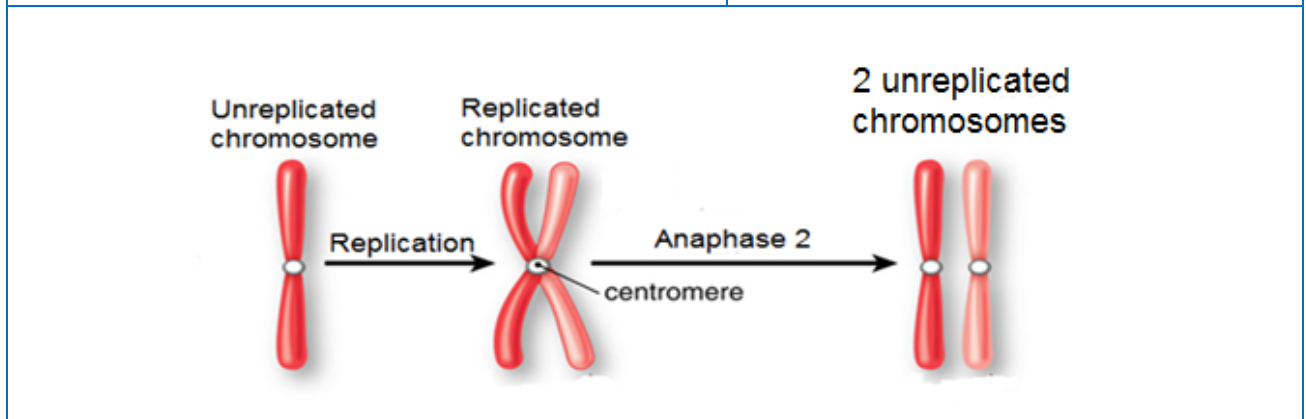

4.4 PROCESS OF MEIOSIS - EXAM TIPS/TECHNIQUES/NOTES

Meiosis topic is linked to Mitosis taught from grade 10. Meiosis can be divided into two parts, Meiosis I and Meiosis II.

First meiotic division

Prophase I

- Nuclear membrane and nucleolus start to disappear.
- Centrosome splits and the two centrioles move apart forming spindle fibres.
- Chromatin network condenses into individual chromosomes and pairs of homologous chromosomes lie next to each other forming a bivalent.
- Inner chromatids from each homologous chromosomes overlap and touch each other at a point called the **chiasma** (plural: chiasmata) in a process called crossing over
- Chromatid segments break off and are exchanged, resulting in the exchange of genetic material.
- This process is called **crossing over** and it brings about **variation**.

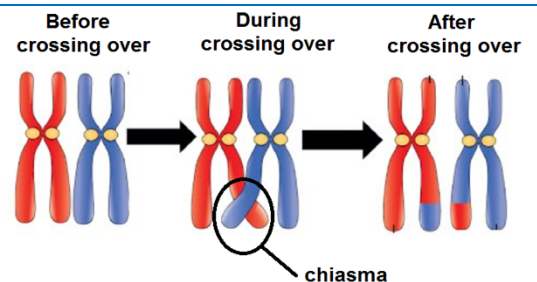
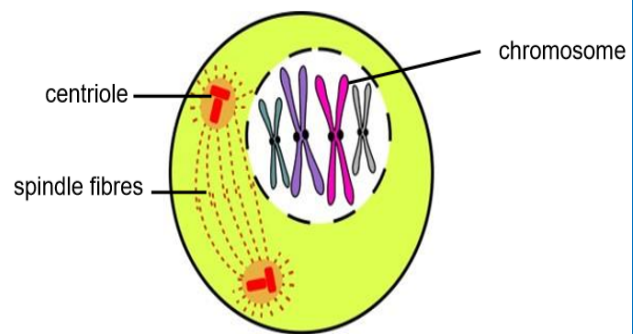

Metaphase I

- **Homologous chromosomes move to the middle of the cell (the equator).**
- The two homologous chromosomes lie on opposite sides of the equator parallel to each other.
- Which homologous chromosome lies on which side of the equator is totally up to chance.
- This is called **random arrangement** and brings about further **variation**.
- Each chromosome in the homologous pair becomes attached to a spindle thread by the centromere.

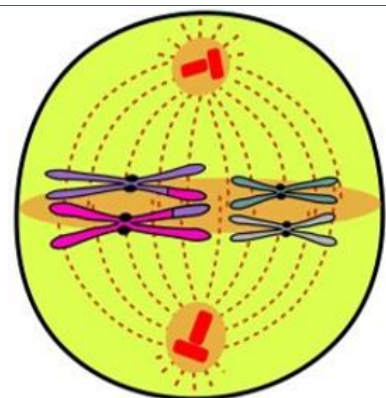

Anaphase I

- One **whole chromosome** from each pair is pulled to **opposite poles** by contraction of the spindle fibres
- This separates the homologous chromosomes – one to each pole.

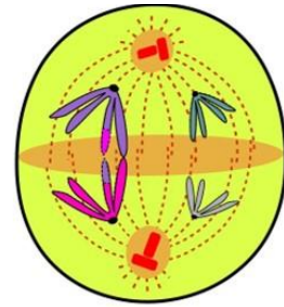

Telophase I

- A new nuclear membrane forms around the group of chromosomes at each pole.
- Nucleolus returns.
- **Cytokinesis (division of cytoplasm)** splits the mother cell into two daughter cells.
- **Important:** Each daughter cell now has **half the number of chromosomes (i.e., is haploid)** and each has a slightly **different** genetic make-up due to crossing over.

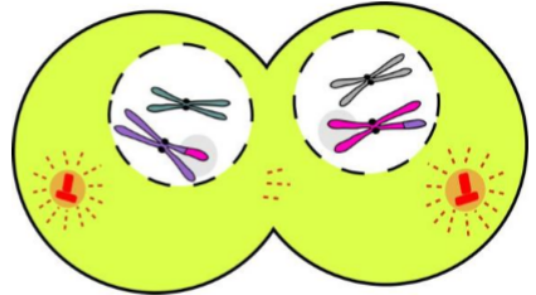

Second meiotic division

The second meiotic division takes place in both daughter cells formed during Meiosis I.

Prophase II

- Nuclear membrane and nucleolus start to disappear.
- Centrosome splits into two centrioles and a spindle forms.
- Chromosomes are NOT in pairs

Remember: Each chromosome is made of TWO chromatids

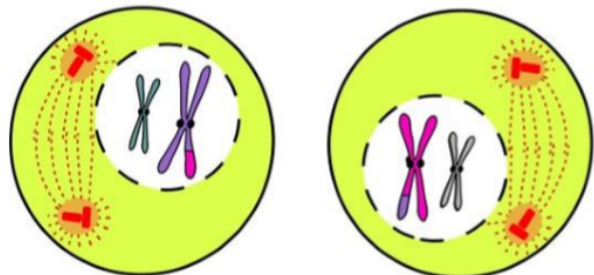

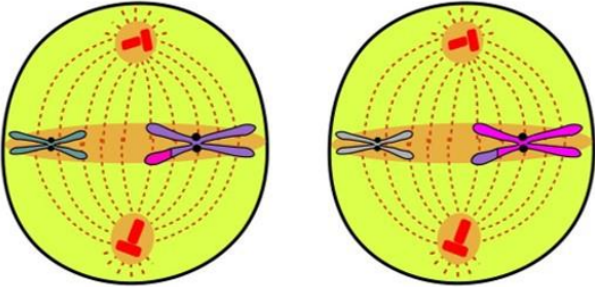
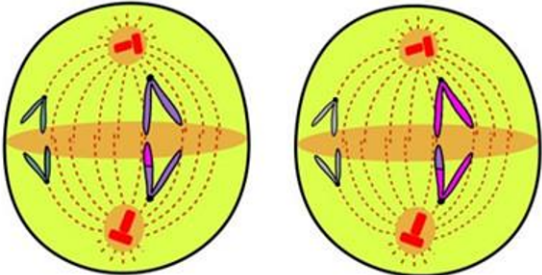
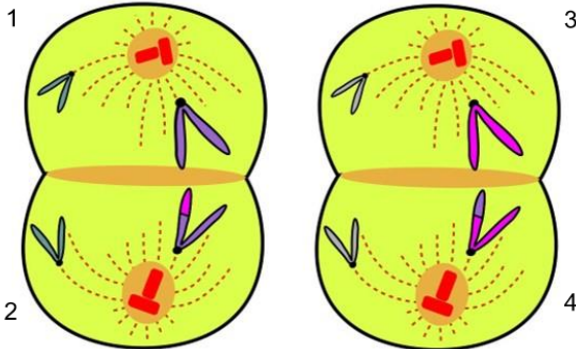
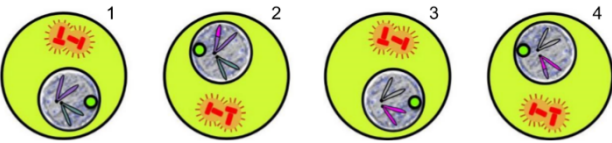
<p>Metaphase II</p> <ul style="list-style-type: none"> • Single chromosomes arrange themselves randomly along the equator with the centromere in line with the equatorial plane. • Which chromatid faces which pole is totally up to chance. • Each chromosome becomes attached to a spindle fibre. 	
<p>Anaphase II</p> <ul style="list-style-type: none"> • Centromere splits separating each chromosome into two daughter chromosomes, each pulled to opposite poles. 	
<p>Telophase II</p> <ul style="list-style-type: none"> • A new nuclear membrane forms around the unreplicated chromosomes at each pole • Cytokinesis splits the cell into two new cells 	
<p>Important: As Meiosis II took place in TWO cells, there will now be FOUR daughter cells. These cells will be haploid and genetically different to each other.</p>	

The purposes of reduction division (meiosis)

- Meiosis is referred to as a **reduction division** because it halves the number of chromosomes in the nucleus of a cell.
- Gametes that form by meiosis have half the number of chromosomes found in somatic cells

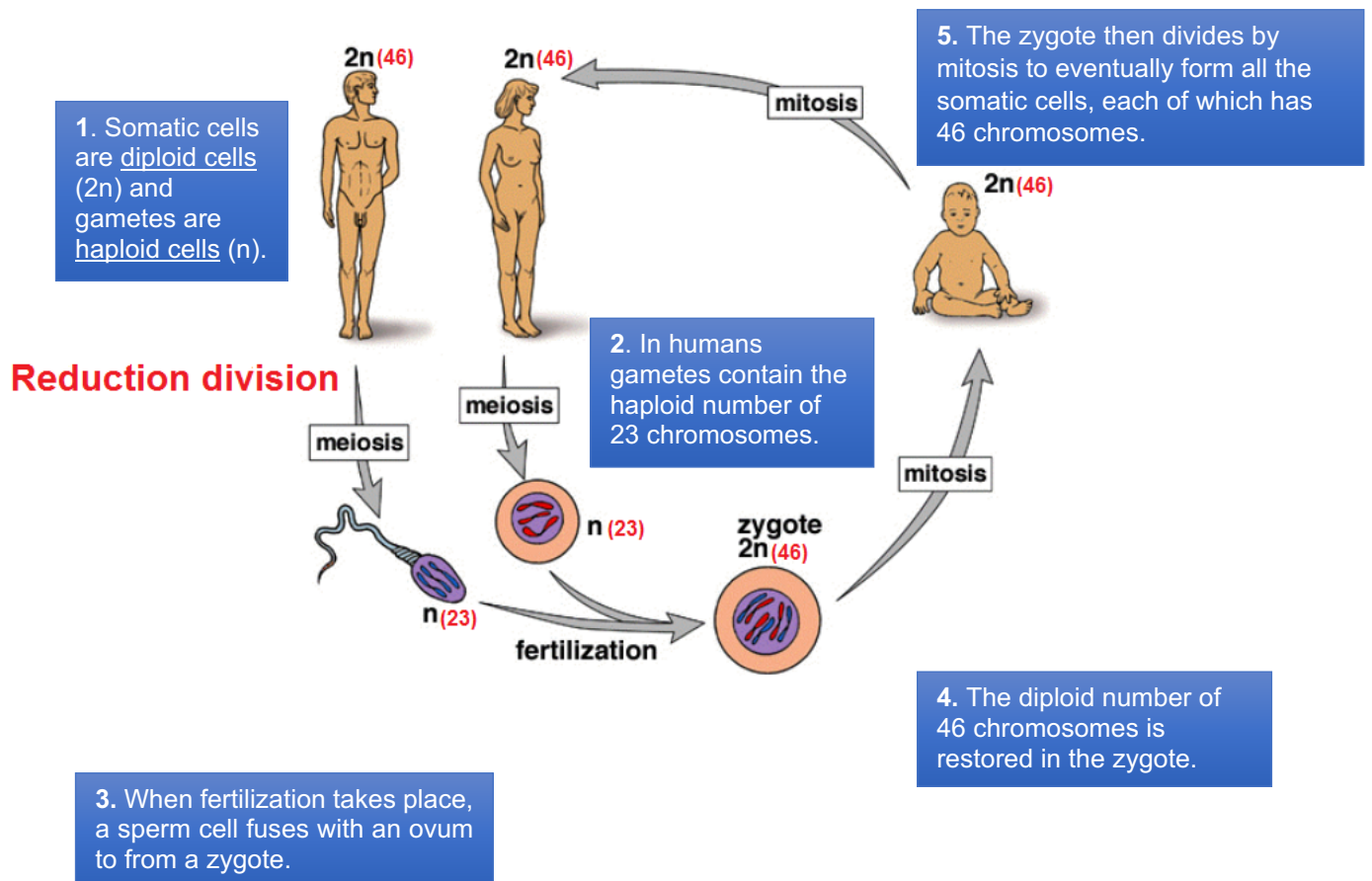

- Meiosis ensures that the chromosome number in the body cells of an organism remains constant from the parents to their offspring and from generation to generation.

Site of meiosis in plants and in animals

- Meiosis is a cell division that usually takes place **in the sex cells**.
- **In plants**, meiosis occurs **in the anther** to produce pollen grain and in the ovary to produce the ovule.
- **In humans**, meiosis occurs **in the testis** to produce sperms and in the ovary to produce an ovum.

Differences between Mitosis and Meiosis

There are two types of cell divisions that takes place in plants and animals, mitosis and meiosis .	Mitosis is a process whereby one cell makes an identical copy of itself and gives rise to two cells that are genetically identical .	Meiosis produces four sex cells that have half the number of chromosomes of the parent cell, and are genetically different from the parent cell.
There are two types of cells in a plant or animal's body, body cells (somatic cells) and sex cells (gametes).	Mitosis deals with the formation of somatic cells ,	while meiosis deals with the formation of gametes (gametogenesis).

4.5 PRACTICE QUESTIONS on MEIOSIS

1.1 The diagram below shows the karyotypes of two individuals.

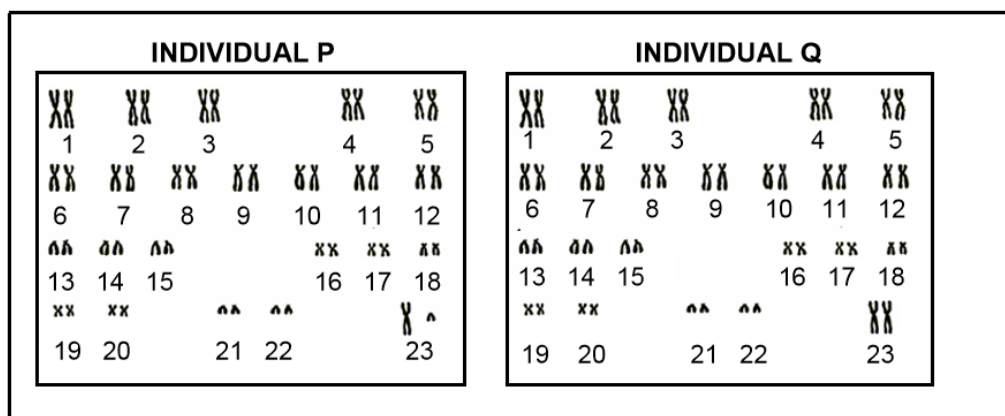

(a) State the gender of individual P.

Look at chromosome pair 23, the Gonosomes are of different size and shape (XY)

Male ✓

- (b) **Give ONE reason why the diagram above represents the chromosomes of a human.**
Count the chromosome number /pairs in the karyotype
NB different species have different chromosome numbers (This karyotype has 46 chromosomes)

It represents a human because it has 46 chromosomes ✓ / 23 pairs of chromosomes which is a unique feature in humans

- (c) **How many chromosomes will be found in?**

- (i) **A human sperm cell**

It is a gamete formed by meiosis which is a reduction division, so it is haploid

23 ✓ chromosomes

- (ii) **Muscle cell**

It is a somatic cell - part of the body therefore diploid

46 ✓ chromosomes

- (iii) **The somatic cells of a normal mother who has a son with Down syndrome**

46 ✓ chromosomes (*Note: It is the son who will have 47*)

- 2.1 **A chemical used in laboratories prevents spindle fibres from forming in cells undergoing meiosis. As a result meiosis cannot start on the completion of interphase.**

In an investigation, this chemical was added to cells in the anthers of the flowers of rice plants. Each cell in the anther has 24 chromosomes.

What is the expected number of chromosomes in each cell at the end of the investigation?

- A 12 replicated chromosomes
B 24 replicated chromosomes ✓
C 24 unreplicated chromosomes
D 48 unreplicated chromosomes

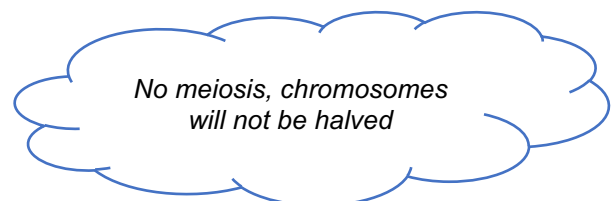

2.2 The diagrams below represent various phases of meiosis.

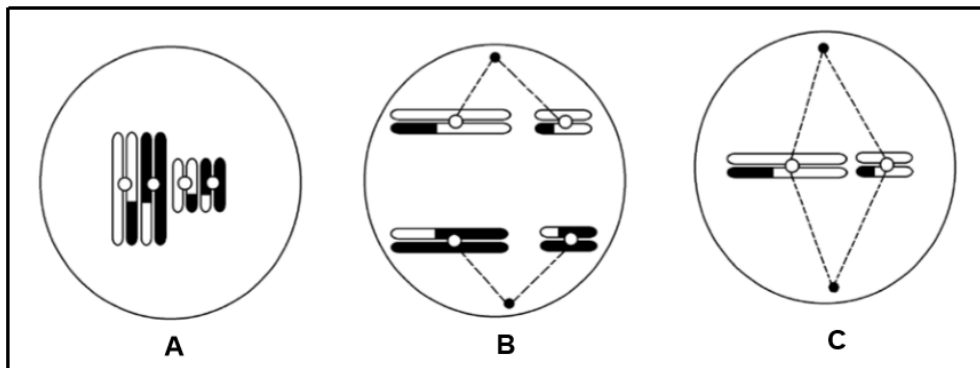

(a) Identify the phase of meiosis in diagram:

- (i) A – prophase I ✓
- (ii) B- Anaphase I ✓
- (iii) C – Metaphase II ✓

DIAGRAM A	DIAGRAM B	DIAGRAM C
<i>Know the event that is unique to a particular phase</i>	<i>Shows separation of replicated chromosomes</i>	<i>Single chromosomes are at the equator</i>
<i>Know the difference between meiosis I & II</i>	<i>If it was anaphase II unreplicated chromosomes would be separating</i>	<i>If it was metaphase I, homologous chromosomes would be at the equator</i>

(b) Draw a labelled diagram to show the cells that will be formed at the end of meiosis from the cell in diagram C.

Step 1: Identify whether the question is based on Meiosis I or II
Remember: Each daughter cell in meiosis I will form TWO Gametes. In Meiosis I we have a complete set of chromosomes (diploid) except in Telophase I, but in Meiosis II all the phases show half the number of chromosomes

Step 2: Show the effect of crossing over in each gamete using the correct shading

Step 3: A complete gamete must have a nucleus surrounded by a nuclear membrane, and a complete cell must also be surrounded by a cell membrane

Step 4: The nucleus for a gamete must show an un-replicated chromosome

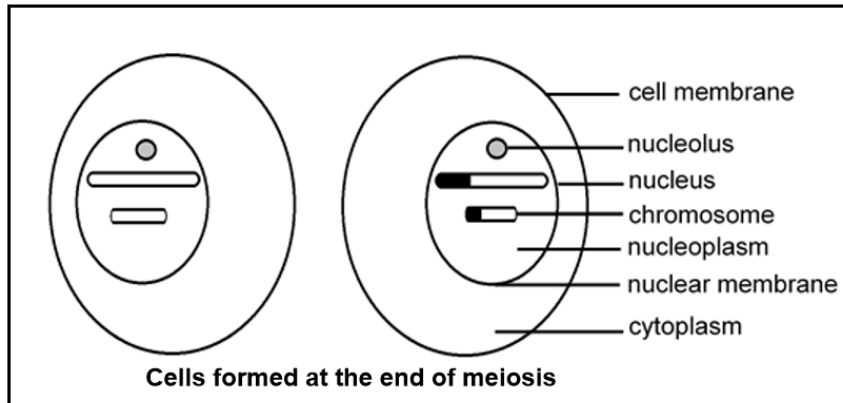

CRITERIA FOR MARKING	
Only two cells drawn (D)	1 mark
Each cell contains only two unreplicated chromosomes (C)	1 mark
Each chromosome is the correct size and correctly shaded (S)	1 mark
Any TWO correct labels	1 mark

2.3 The diagram below represents TWO phases of meiosis

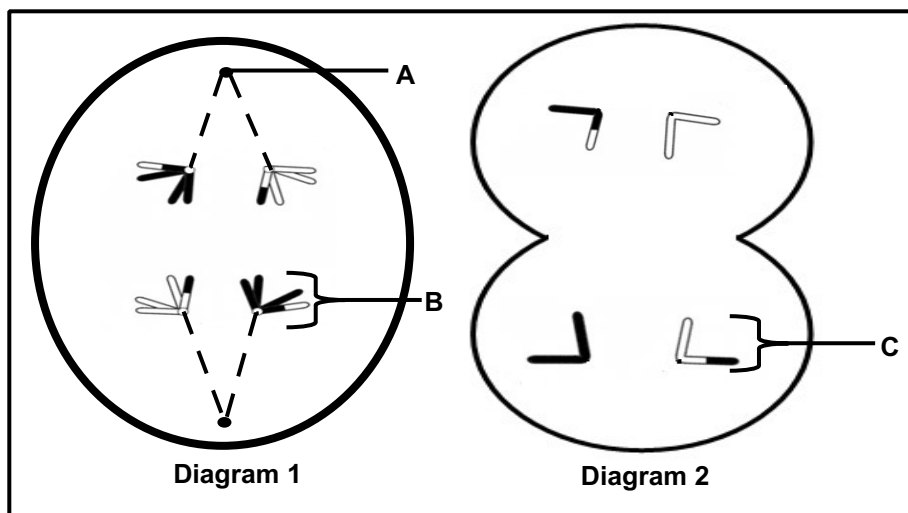

2.3.1 Identify part A. - centriole ✓

2.3.2 Describe the events that took place in the phase before the one represented in diagram 2.

First identify diagram 2 as telophase II because cell membrane is starting to invaginate. So, a phase that occurs before this one is anaphase II. Therefore, describe the events in anaphase II as follows

- Spindle fibres contract✓
- Centromeres split✓
- Each unreplicated chromosome is pulled to the opposite pole✓

2.3.3 Name the process that causes the chromosomes to have a combination of genes as shown in the diagrams.

Crossing over✓

2.3.4 Give ONE reason why the process named in QUESTION 2.3.3 is important.

Leads to genetic variation✓

2.3.5 If this was a human cell, how many chromosomes would be present in the cell during the phase represented in diagram 1

46✓

2.3.6 Structure B and structure C are both chromosomes. Explain why they are structurally different.

Check terminology, be able to differentiate between replicated and unreplicated chromosome (picturing a diagram helps in remembering definitions)

- structure B has two DNA molecules✓
- is a replicated chromosome
- it is made up of TWO chromatids✓
- Structure C has ONE DNA molecule✓, it is an un-replicated chromosome
- Structure C has one chromatid ✓

2.4 The diagram below represents a cell during a phase of meiosis.

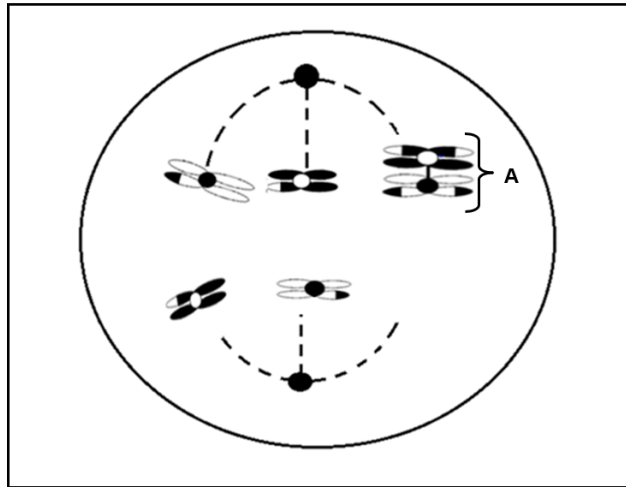

2.4.1 Name the process taking place at A.

Homologous chromosomes have failed to separate

Non-disjunction ✓

2.4.2 State the phase of meiosis illustrated above.

Identify what is separating, is it homologous chromosomes, or is it the splitting of centromere, separating chromatids. What is moving towards the poles? Is it a replicated chromosome or an unreplicated chromosome?

Anaphase I ✓

2.4.3 Name the type of mutation that occurred in the cell.

Check whether it involves a change in the number and size of chromosomes.

Note: if it only involves a change in the number and sequence of nucleotides, it is a gene mutation

Chromosomal mutation ✓

2.4.4 Give the number of chromosomes that will be present in a normal gamete of the species whose cell is represented above.

Identify the diploid cell which represents the chromosome number for somatic cells of the parent. Then work out half the number of chromosomes, Note this half number of chromosomes appears at telophase II and is maintained throughout all the stages of meiosis II Three ✓

2.4.5 Give the chromosome number of the four gametes formed at the end of Meiosis II.

- *Determine the number for a full set of chromosomes (in this case (six*
- *Identify how many pairs chromosomes have been affected by non-disjunction (one pair)*
- *Normal separation will be for four chromosomes – to give two chromosomes on each daughter cell.*
- *Because of non-disjunction in the third pair, both chromosomes will go to the same daughter cell, causing it to have four chromosomes.*
- *The other one will have two chromosomes. Note this number will*
- *be maintained in all stages of meiosis II*

Two cells will have four unreplicated chromosomes✓

Two cells will have two unreplicated chromosomes✓

2.4.6 Describe the chromosome behaviour in the phase before the one represented in the diagram.

- *PMAT- prophase, metaphase, anaphase, telophase*
- *Identify whether it is meiosis I or meiosis II*
- *Identify the stage in the diagram shown- anaphase I*
- *Work backwards to determine the phase before the one drawn*
- *Metaphase I.*

Homologous chromosomes were randomly arranged at the equator✓

2.4.7 Explain how the new zygote will be affected if a gamete resulting from the error in meiosis at A is involved in fertilisation with a normal gamete

- *Determine the number of chromosomes in the gamete that was affected by non-disjunction (1 gamete has four, other one has two)*
- *Work chromosome number expected in a normal gamete which has not undergone non-disjunction (three)*

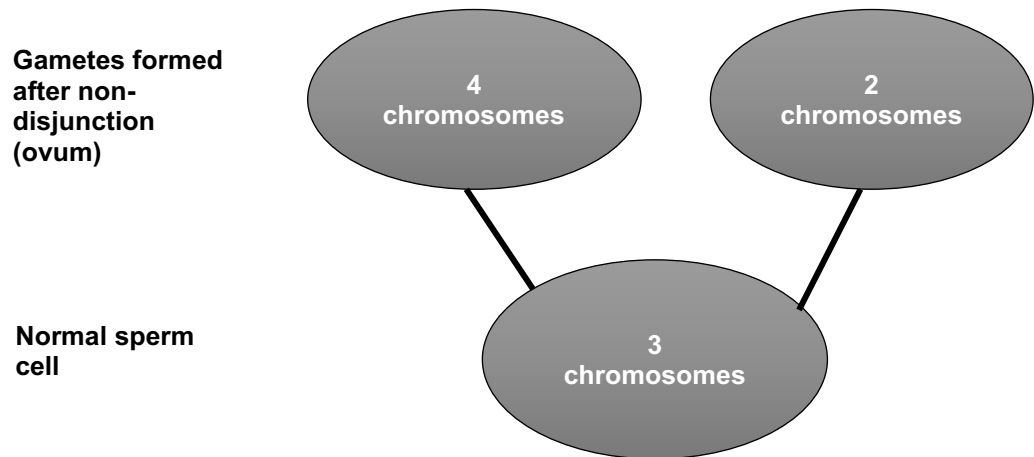

An ovum with 4 unreplicated chromosomes ✓ will be fertilized by a normal sperm cell with 3 unreplicated chromosome ✓ resulting in a zygote with 7 chromosomes ✓ instead of 6 ✓

or

An ovum with 2 unreplicated chromosomes ✓ will be fertilized by a normal sperm cell with 3 unreplicated chromosome resulting in a zygote with 5 chromosomes ✓ instead of 6 ✓

4.6 TYPICAL EXAM QUESTIONS

QUESTION 1 (DBE, Nov. 2018, Paper 2)

1.1 The diagram below shows the structure of a chromosome

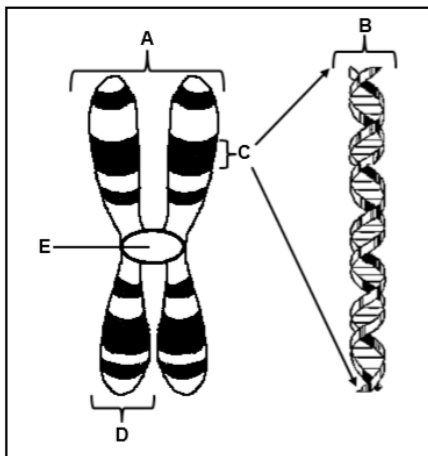

1.1.1 Identify parts D and E. (2)

1.1.2 How many pairs of chromosomes are found in a normal human sperm cell? (1)

1.1.3 Give only the LETTER of the part that:

(a) Attaches to the spindle fibres during cell division (1)

(b) Represents a gene (1)

(5)

QUESTION 2 (DBE, May/June 2018, Paper 2)

2.1 Diagrams 1 to 3 below represent some of the phases of meiosis shown in the correct order.

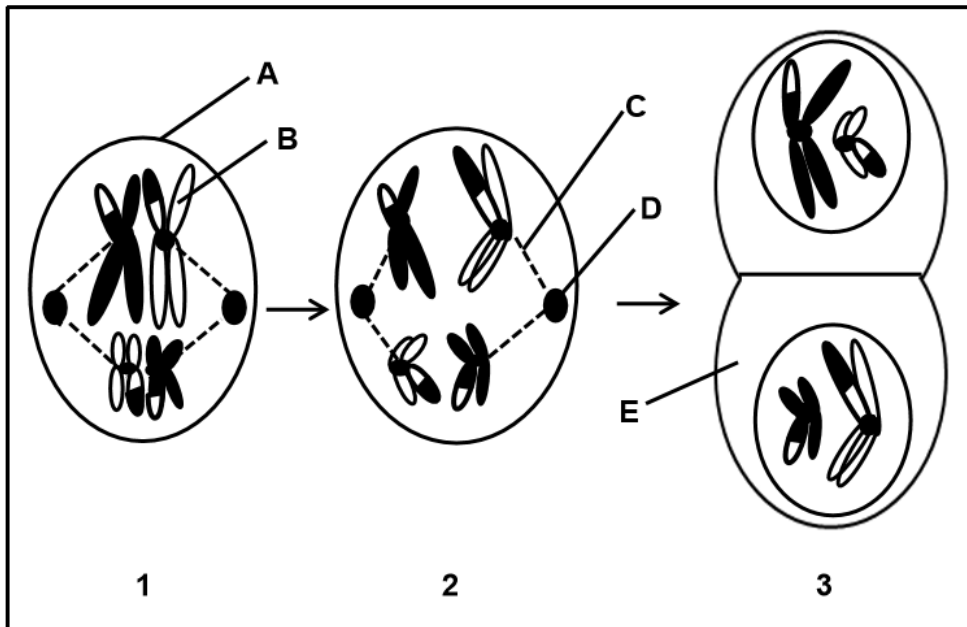

2.1.1 Identify the phase represented by diagram

- (a) 1 (1)
- (b) 3 (1)

2.1.2 Give the LETTER only of the part that

- (a) Contains DNA (1)
- (b) Attaches to the centromeres of chromosomes (1)
- (c) Forms the spindle fibres (1)

2.1.3 Name the organ in a human male where meiosis occurs. (1)
(6)

QUESTION 3 (DBE, May/June 2018, Paper 1)

3.1 The diagrams below represent two phases of meiosis in an organism.

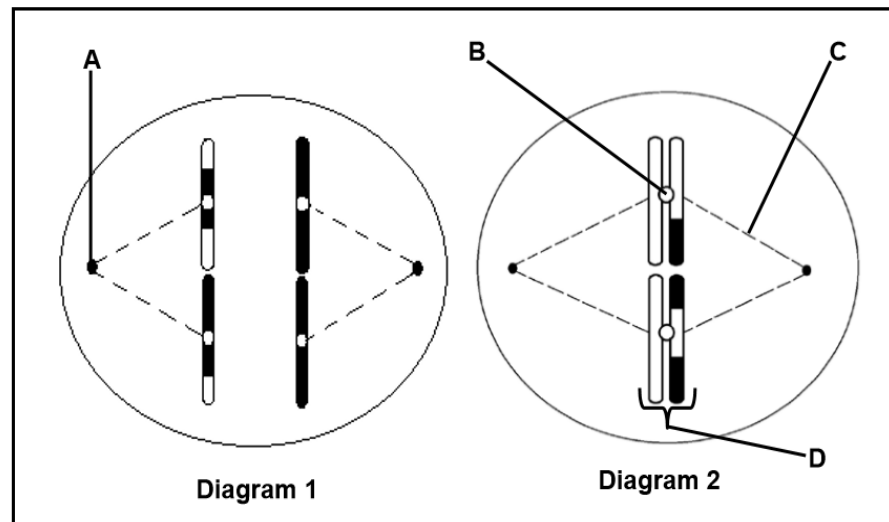

3.1.1 Identify the phase of meiosis represented in Diagram 1. (1)

3.1.2 Identify part:

(a) A (1)

(b) B (1)

(c) C (1)

3.1.3 State what happens to structure D in the next phase of meiosis. (1)

3.1.4 Name the process during which genetic material was exchanged, as shown in the diagrams above. (1)

3.1.5 State the consequence if the process named in QUESTION 3.1.4 does not occur (1)

3.1.6 Give the number of chromosomes present in:

(a) The original parent cell in this organism (1)

(b) A human cell in the same phase as that shown in Diagram 2 (1)

(9)

QUESTION 4 (DBE, Nov 2013, Paper 1)

4.1 The diagram below represents the distribution of chromosome pair 21 as it appears in the gametes at the end of meiosis II in the human male

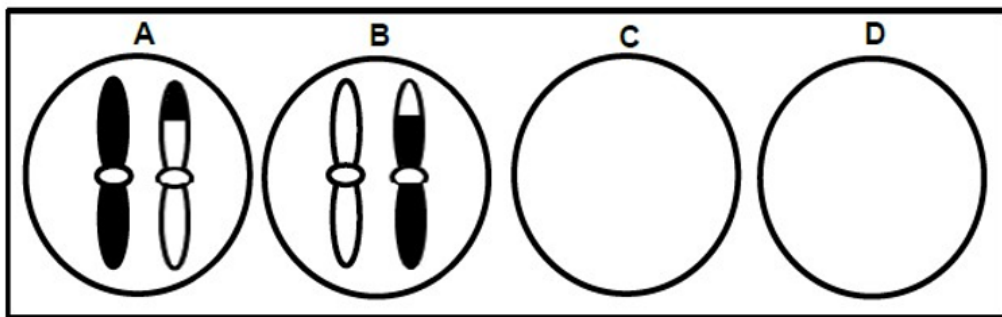

4.1.1 Explain why the gametes represented by diagrams C and D do not have any chromosomes (3)

4.1.2 If gamete A is involved in fertilisation, describe how this may result in down syndrome (3)

4.1.3 Due to the process of crossing over, the chromosomes in diagram A and B appear different from each other

(a) Identify the phase of meiosis during which crossing over occurs (1)

(b) Describe the events during crossing over (3)

(10)

4.7 SOLUTIONS TO MEIOSIS PRACTICE QUESTIONS

QUESTION 1

1.1.1 D- chromatid ✓ (2)
E- centromere ✓

1.1.2 23 ✓ (1)

1.1.3 (a) E ✓ (1)

(b) C ✓ (1)

(5)

QUESTION 2

2.1.1 (a) Metaphase I ✓ (1)

(b) Telophase I ✓ (1)

2.1.2 (a) B ✓ (1)

(b) C ✓ (1)

(c) D ✓ (1)

2.1.3 Testis ✓ (1)

(6)

QUESTION 3

- 3.1.1 Anaphase II✓ (1)
- (a) Centriole✓ (1)
 - (b) Centromere (1)
 - (c) Spindle fibre✓ (1)
- 3.1.2 The chromatids separate /centromere splits✓ (1)
- 3.1.3 Crossing over✓ (1)
- 3.1.4 Reduces genetic variation✓ (1)
- 3.1.5 (a) 4✓ (1)
- (b) 23✓ (1)
- (9)**

QUESTION 4

- 4.1.1 Due to non – disjunction / non-separation of a chromosome pair during anaphase I✓
Two chromosomes moved to one pole✓ and none moved to the other pole✓ (3)
- 4.1.2 Gamete A will have 24 chromosomes✓ / an extra chromosome
When it fertilises a normal ovum✓ / gamete with 23 chromosomes
The zygote will have 47 chromosomes at position 21✓ / 47 chromosomes (3)
- 4.1.3 (a) Prophase I✓ (1)
- (b) Adjacent chromatids of homologous chromosomes cross✓
at a point called chiasma✓
There is an exchange of DNA segments ✓ / genetic material (3)
- (10)**

5. REFERENCES

- DBE Exam guidelines for learners
- GDE ATP
- 2015-2020 NSC past papers
- 2014-2020 national diagnostic report on learner performance
- Approved grade 12 national textbooks
- Internet
- Gauteng grade 12 Life Sciences Revision booklet
- Gauteng grade 12 Life Sciences Exam Kit
- NMD grade 12 life sciences workbook

6. ACKNOWLEDGEMENT

The Department of Basic Education (DBE) gratefully acknowledges the following officials for giving up their valuable time and families and for contributing their knowledge and expertise to develop this resource booklet for the children of our country, under very stringent conditions of COVID-19:

Writers: Arnold M. Johannes (Eastern Cape) and Phumzile Dlamini (Eastern Cape)

Reviewers: Mpho Mokgotlhoa, Ntombi Dladla, Julia Tladi, Lucas Mothibedi Mfolo, Gezani Phineas Chavani, Avusiwe Madikane, Mthembi GB, Chauke Magezi Elias, Jacoline Jones

DBE Subject Specialist: Kanthan Naidoo

The development of the Study Guide was managed and coordinated by Ms Cheryl Weston and Dr Sandy Malapile

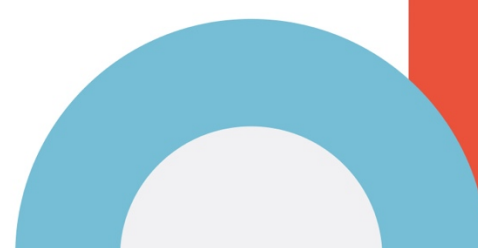
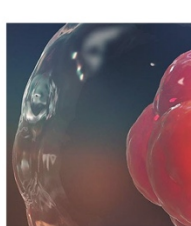
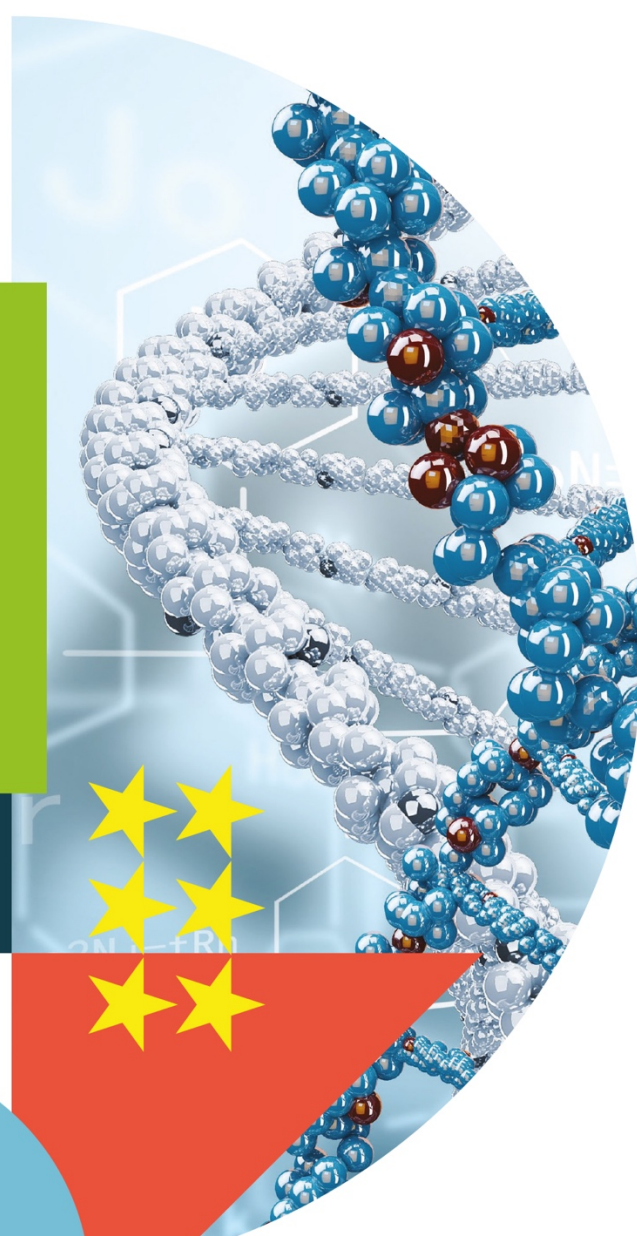
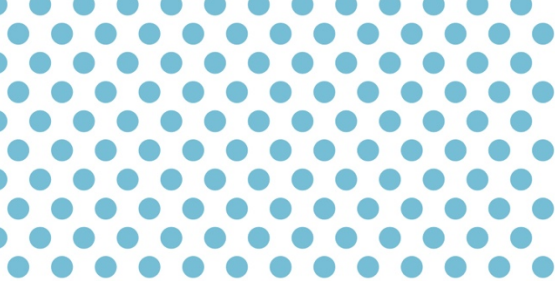

basic education
Department:
Basic Education
REPUBLIC OF SOUTH AFRICA

ISBN: 978-1-4315-3518-7
High Enrolment Self Study Guide Series
This publication is not for sale.
© Copyright Department of Basic Education
www.education.gov.za | Call Centre 0800 202 993