



Mathematical

LITERACY

SELF STUDY GUIDE BOOKLET 2B
MAPS, PLANS AND OTHER
REPRESENTATIONS OF
THE WORLD



TABLE OF CONTENTS		Page
1.	Introduction	3
2.	How to use this self-study guide	4 - 5
3.	3.1 Maps, plans and other representations of the world	
	3.1.1 Key concepts	6
	3.1.2 Scale	7 - 10
	3.1.3 Maps	11 - 29
	3.1.4 Plans	30 - 44
	3.1.5 Models	45 - 49
	3.2 Solutions to practice questions	
	3.2.1 Scale	50
	3.2.2 Maps	51 - 52
	3.2.3 Plans	52 - 54
	3.2.4 Models	55 - 56
4	Examination guidance	57 - 59
5	Study and Examination Tips	60
6.	References	61
7.	Acknowledgements	62



1. INTRODUCTION

The declaration of COVID-19 as a global pandemic by the World Health Organisation led to the disruption of effective teaching and learning in many schools in South Africa. The majority of learners in various grades spent less time in class due to the phased-in approach and rotational/ alternate attendance system that was implemented by various provinces. Consequently, the majority of schools were not able to complete all the relevant content designed for specific grades in accordance with the Curriculum and Assessment Policy Statements in most subjects.

As part of mitigating against the impact of COVID-19 on the current Grade 12, the Department of Basic Education (DBE) worked in collaboration with subject specialists from various Provincial Education Departments (PEDs) developed this Self-Study Guide. The Study Guide covers those topics, skills and concepts that are located in Grade 12, that are critical to lay the foundation for Grade 12. The main aim is to close the pre-existing content gaps in order to strengthen the mastery of subject knowledge in Grade 12. More importantly, the Study Guide will engender the attitudes in the learners to learning independently while mastering the core cross-cutting concepts.

2. HOW TO USE THIS SELF STUDY GUIDE

- This study guide covers selected sections of Maps, plans and other representations of the physical world which form part of paper 2.
- The topic is drawn from the CAPS Grade 10 – 12 curriculum. Selected sections are presented in the following way:
 - What you should know at the end of the section.
 - Explanation of key concepts.
 - Summary/Notes.
 - Worked examples.
 - Practice questions.
 - Solutions to practice questions.
- Mathematical Literacy is a highly contextualised subject. Whilst every effort has been taken to ensure that skills and concepts you will be examined on are covered in this study guide, it is in fact the context used in the examination that will determine how these skills and concepts are assessed.
- This study guide covers all the cognitive levels.
- Go through the worked examples on your own.
- Do practice examples on your own. Then check your answers.
- Read symbols and explanation table below to understand how marks are allocated.

Symbol	Explanation
M	Method
M/A	Method with accuracy
MCA	Method with consistent accuracy
CA	Consistent accuracy
A	Accuracy
C	Conversion
S	Simplification
RT/RG/RD	Reading from a table/graph/diagram
SF	Correct substitution in a formula
O	Opinion/Example/Definition/Explanation
P	Penalty, e.g. for no units, incorrect rounding off, etc
R	Rounding off
NPR	No penalty for rounding
NPU	No penalty for the units
AO	Answer only, if correct, full marks

- Reward yourself for things you get right.
- If any of your answers are incorrect, make sure that you understand where you went wrong, before moving on to the next section.
- The study guide covers both generic and subject specific examination tips. You are expected to read and understand the tips, so that you are able to study more effectively

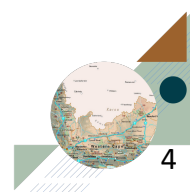

3.1 Topic: Maps, Plans and other representations of the physical world.

2.1.1 Key Concepts.

2-D models	A diagram or picture having length and width only.
2-dimensional plans	A plan or design having length and width only, but possibly representing three dimensional objects.
3-D models	A dimensional construction of real-life objects.
Actual length	Accurate length
Bar scales	Presented as a picture, it means that if you placed a ruler next to this scale, you could determine how many centimeters next to this scale, you could determine how many centimeters represent the specified kilometers
Distance	The length of the space between two points
Elevation map	Information about the profile of a route as seen from the side.
Elevation plans	Show the design and dimensions of the outside of a building from a side view.
Floor plan	Shows the design and dimensions of the inside of a building, from a top view.
Highway	A major road that links major cities.
Length	The measurement of something from end to end
Model:	A thing used as an example to follow and imitate an object (a three-dimensional figure or object)
National road map	Shows major roads linking major cities to each other.
North elevation plan	Shows the side of the building that is in front of you when you are facing the compass direction 'North'
Number scale	A number scale such as 1: 50 000 means that 1 unit on the map represent 50 000 units in real life
Scale	Determines how many times smaller an object shown on a plan or map is that its actual size
Scale drawing	A diagram of a real-life object drawn in proportion.
Scaled elevation plans	Show the design and dimensions of the outside of a building from a side view using a specific scale.
Map:	A symbolic representation of selected characteristics of a place drawn on a flat surface.
Street map	A map of a small area such as a town or city.
Strip map	A map of a section of a travelling route.
Route map	Shows a specific route, for instance for an event, as seen from above.
Location:	A particular place or position.

3.1.2 Scale

Objectives

By the end of this sections learners must be able to:

- Work with two types of scales on maps, plans and in construction of models
- Calculate actual length and distance when map and/or plan measurements are known.
- Calculate map and/or plan measurement when actual lengths and distances are known using a given scale.
- Determine the most appropriate scale in which to draw/ construct a map, plan and/or models.
- Determine the scale in which a map/or plan has been drawn.

Summary

A scale of a map is a ratio of the distance on the map to the actual distance on ground. It is written in the form,

$$\text{Image (map) distance: Actual distance} \\ \mathbf{1: 500}$$

Types of scale

There are two types of scale:

a) Bar scale

The bar scale is used to develop the numeric scale, each segment or part must be measured in order to create a ratio scale. It is given as a picture **e.g.**

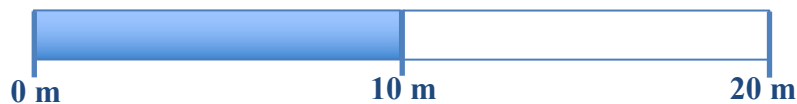

The length of the bar needs to be **measured with a ruler**

e.g., If the length of the bar from 0m to 20m is 8cm then it means 8cm on the map is equal to 20m in reality/on ground/ on land.

That means the scale is 8cm: 20m and it can be simplified like we simplify a ratio.

e.g, 8cm : 200cm

1 : 25

NB: Scale factor is 25

Advantages and disadvantages of a bar scale

Advantages	Disadvantages
Bar scales are quick and easy to use.	Measurements (using a ruler, string or markings) obtained using bar scales tend to be less accurate.
You may be able to determine actual lengths and distances without doing calculations.	Bar scales may still require calculation actual lengths and distances.

b) Number/Ratio/Numeric Scale

This scale is expressed as a ratio, e.g. 1:500. This means that for every 1 unit on the map/image is equivalent to 500 units in reality.

Advantages and disadvantages of a number scale

Advantages	Disadvantages
Number scales are more accurate than bar scales.	Number scales require the use of calculators in determining actual distances.
Number scales are more convenient to use when working with small scales e.g. 1: 50 000 000.	With digital printing, number scales become inaccurate and useless if there is any resizing of the map or plan.



WORKED EXAMPLES

1. You are given a map with the number scale of 1: 60. You measure a length (on the map) of 10 cm. What is this distance in real life?
2. The distance on the map from Durban to Pietermaritzburg is 2,5 cm. Use the number scale of 1:3 120 000 to calculate the actual distance in km. You may use the formula:

$$\text{Actual distance} = \frac{\text{Distance on the map} \times \text{Scale}}{\text{Conversion}}$$

3. You are given the following bar scale:

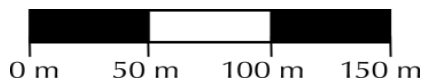

You measure the distance on the map to be 15 cm. What is the actual distance?

Solutions for worked examples

1. Scale is 1: 60.
= 10 cm \times 60
= 600 cm
= 6 m

NB: 1 m = 100 cm

The distance on the ground (in real life) is 6m.

2. **Actual distance** = $\frac{\text{Distance on the map} \times \text{Scale}}{\text{Conversion}}$

$$\begin{aligned} \text{Actual Distance} &= \frac{2,5 \text{ cm} \times 3\,120\,000}{100\,000} \\ &= 78 \text{ km} \end{aligned}$$

NB: 1 km = 100 000 cm

3. 1 segment = 1,5 cm long, and it represents 50 m.
= 15 cm \div 1,5 cm
= 10 segments
= 10 \times 50
= 500 m

OR

$$1,5 \text{ cm} = 50 \text{ m}$$

$$15 \text{ cm} = a$$

$$\frac{750}{1,5} = \frac{1,5a}{1,5}$$

$$500 = a$$

Therefore 15cm = 500m

Practice Questions

1. You are given a map with the number scale of 1: 500. You measure a distance on the map of 15 cm with your ruler. What is this distance in real life?
2. If the layout plan distance from class A to Class D is exactly 180 mm, determine the actual distance in metres.
You may use the formula:

$$\text{Actual distance} = \frac{\text{Distance on the map} \times \text{Scale}}{\text{Conversion}}$$

3. You are given the following bar scale:

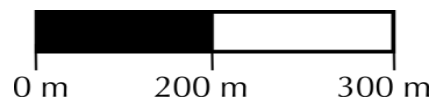

You measure the distance between two points on the map to be 11 cm. What is the distance on the ground?

3.1.3 MAPS

Objectives

By the end of this section learners must be able to:

- Describe the position of an object in relation to the surrounding objects.
- Find locations, follow directions and develop directions for travelling between two or more locations.
- Estimate distances using measurement in a given scale.
- Estimate the time it will take to travel between two or more locations.
- Estimate the amount and cost of fuel that will be used to travel between two or more locations.
- Estimate the average speed travelled during a trip.
- Determine appropriate stopping locations.
- Plan and cost trips using timetables, fare charts, distance charts and budget.
- Work with combination of maps showing different perspectives and scale.
- Interpret compass directions in the context of appropriate maps and plans.
- Understand directions and signboards on roads and in map books.
- Interpret elevation plans of building.

NOTES

SUMMARY

TYPES OF MAPS

SEATING PLANS

- Use symbols and words to show names and or positions of arranged items.
- A key explaining symbol meanings is usually included in the plan.
- Compass direction indicators are sometimes also included.

SEATING PLAN OF A CLASSROOM

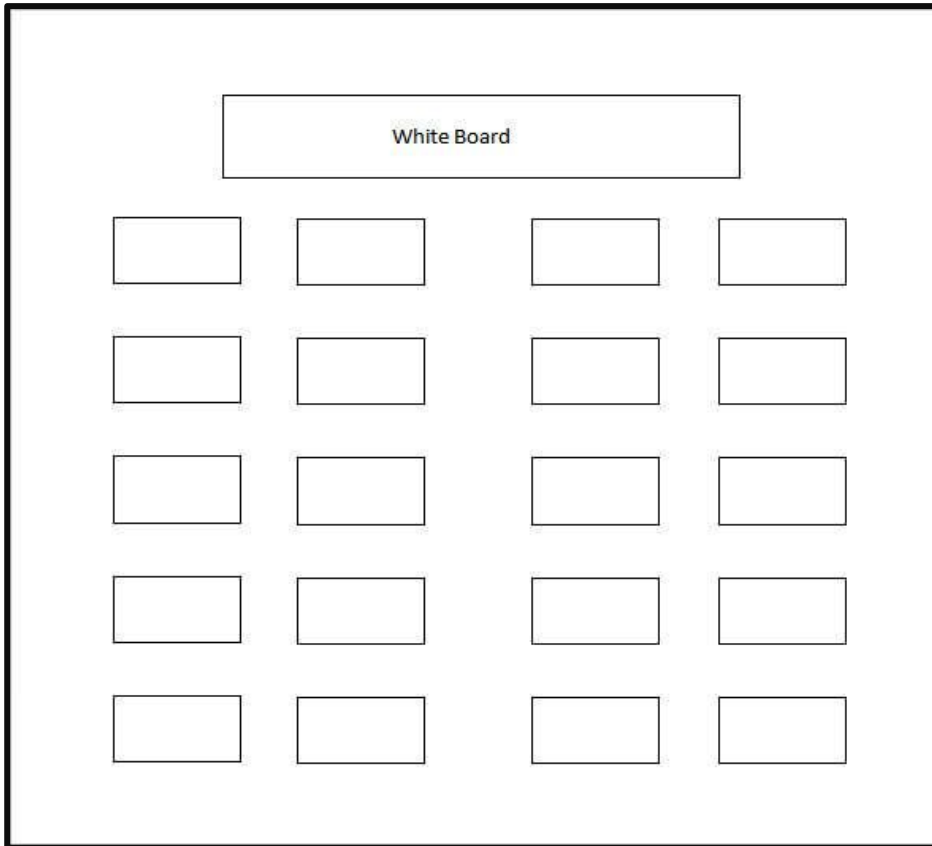

[Source:za.pinterest.com]

LAYOUT PLANS

- Uses icons with names to show different buildings or structures.
- Symbols are also used where necessary to make the diagram clear.
- Compass direction indicators are also common.

LAYOUT OF THE BUILDING

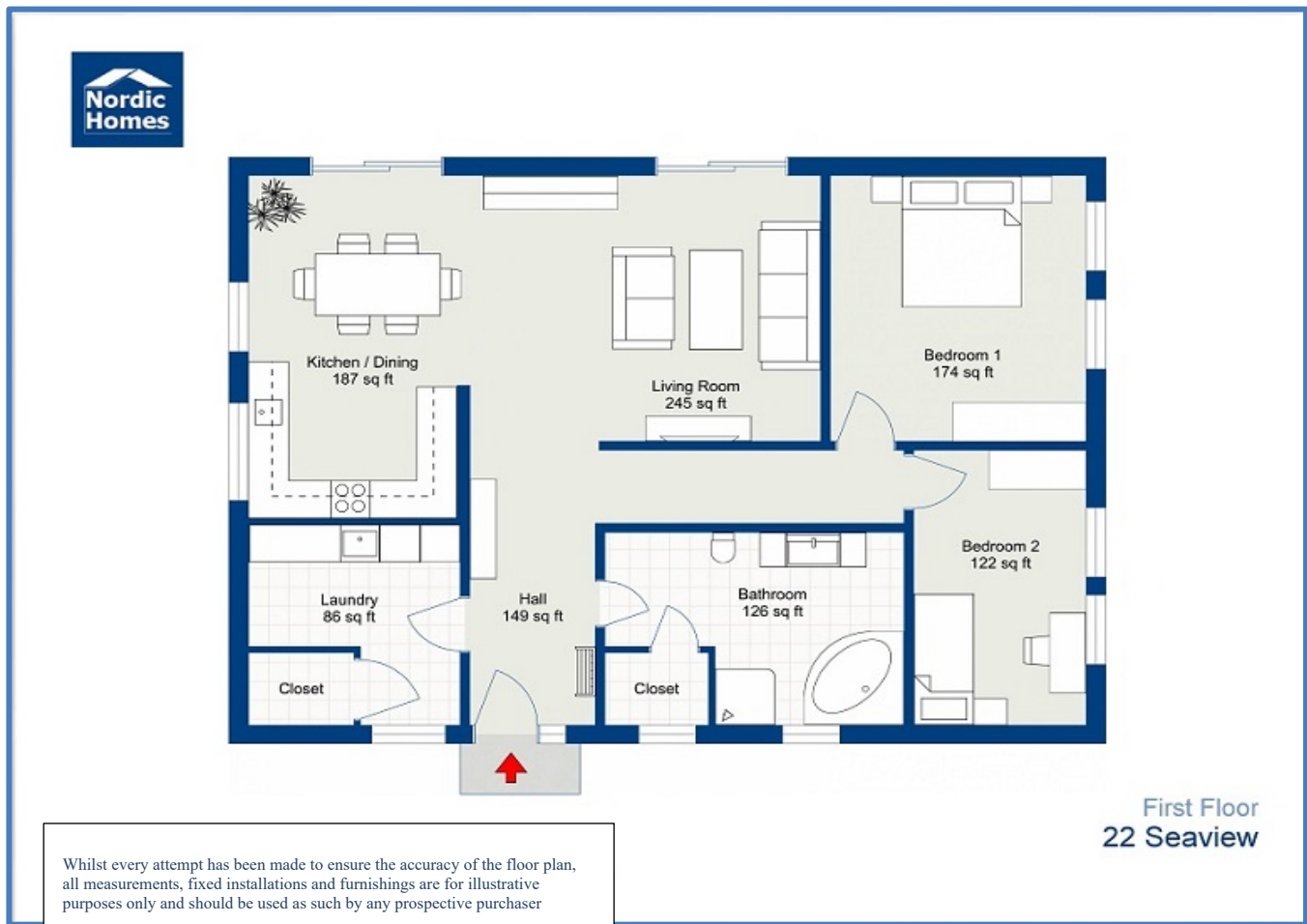

[Source: roomsketcher.com]

LAYOUT OF STORES IN A SHOPPING CENTRE

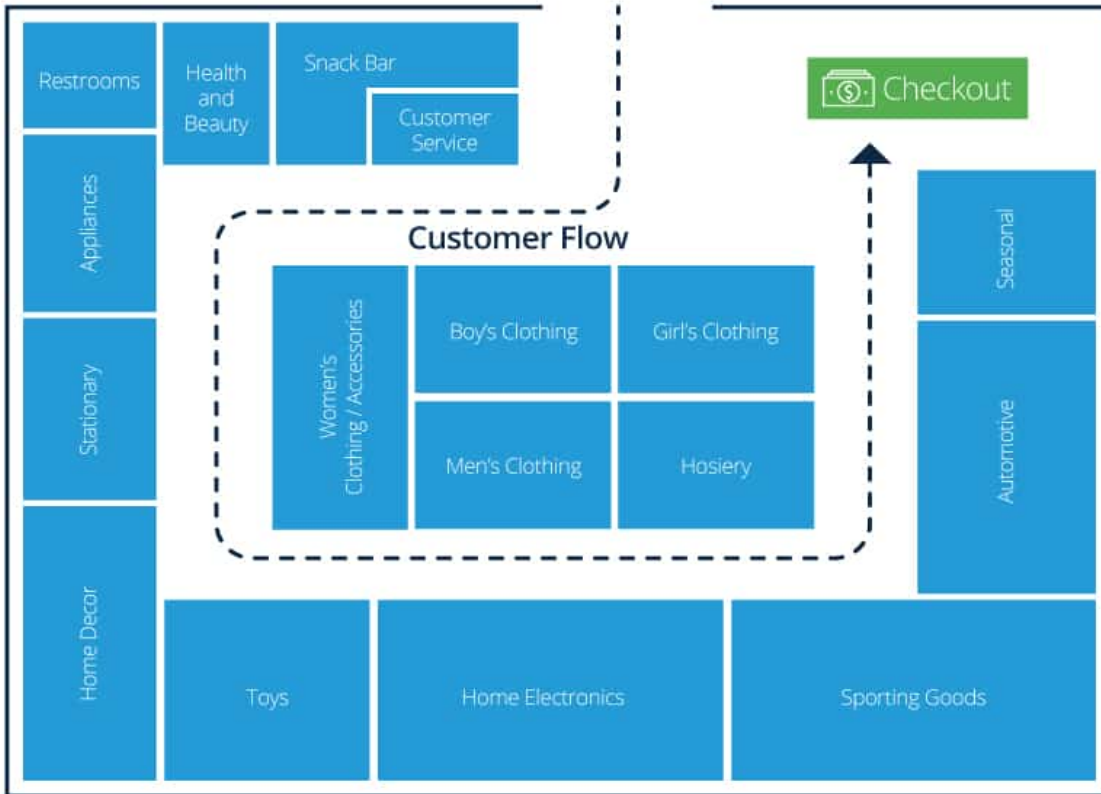

[Source:smartsheet.com]

LAYOUT OF A STADIUM



[Source:blog.ticket.com]

STREET MAPS WITH AND WITHOUT A GRID REFERENCE

- Show aerial pictures of industrial or residential areas.
- Street/avenue/boulevard/road/close names are indicated.
- May also show building positions names.
- May have grid references
- Always drawn to a specified scale.



[Source: mindset]

RESIDENTIAL OR HOUSING MAPS



[Source:fernkloofestate.com]

NATIONAL AND PROVINCIAL ROAD AND RAIL MAPS

- Show aerial pictures of countries and or provinces.
- Always drawn to a specified scale.
- May show a variety of features such as names of cities or towns, road names connecting towns, railway lines, rivers, seas/oceans, etc.
- Names of the roads connecting towns and cities are also shown on the map. The following nomenclature is used for naming roads:
 - N(x) means national road x. For example, N2.
 - R(x) means regional road x. For example, R103.
 - M(x) means local/municipal road x. For example, M13.
- Compass direction indicators always shown



[Source:junglemaps.blogspot.com]

STRIP CHARTS SHOWING DISTANCES ON A PORTION OF A ROAD

- Useful for planning a trip.
- Use straight lines to connect important features along the route such as towns, tourist destinations, dams, etc.
- Distances between places written on a straight line joining the places.
- No relationship between the length of the line joining any two places and the actual distance.

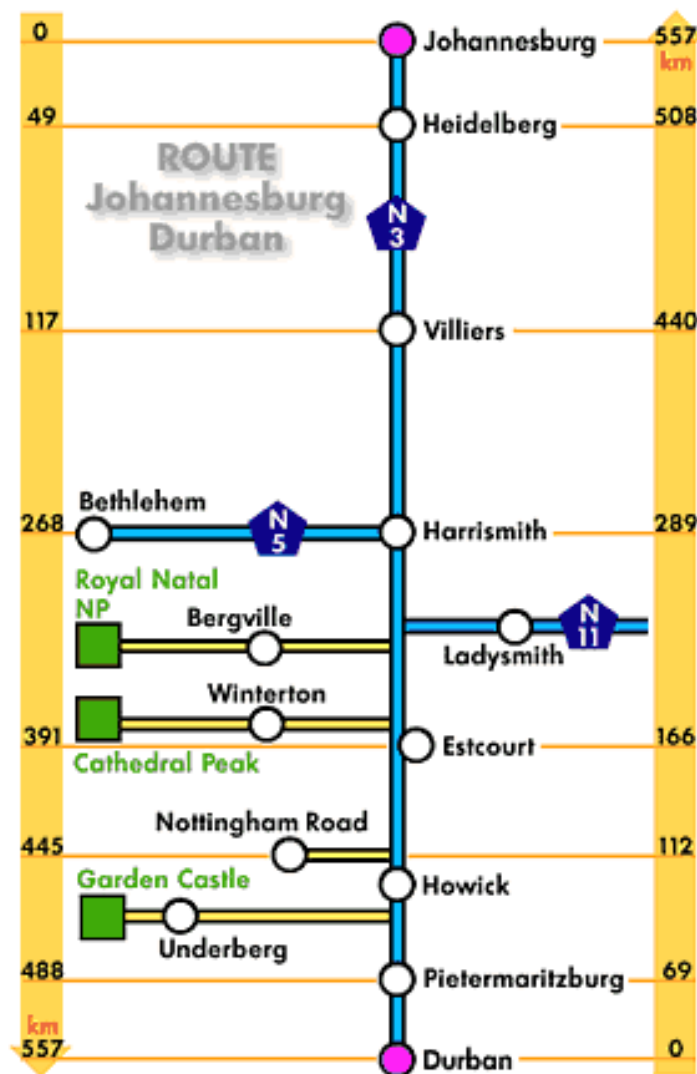

[Source: mindset]

ELEVATION MAP

- These maps show the slopes or various inclinations of a route.
- Names of important features of the route are given on the map.
- Useful for preparations for a walk, fun-run or marathon.
- Usually include both the starting and finishing points of a route.

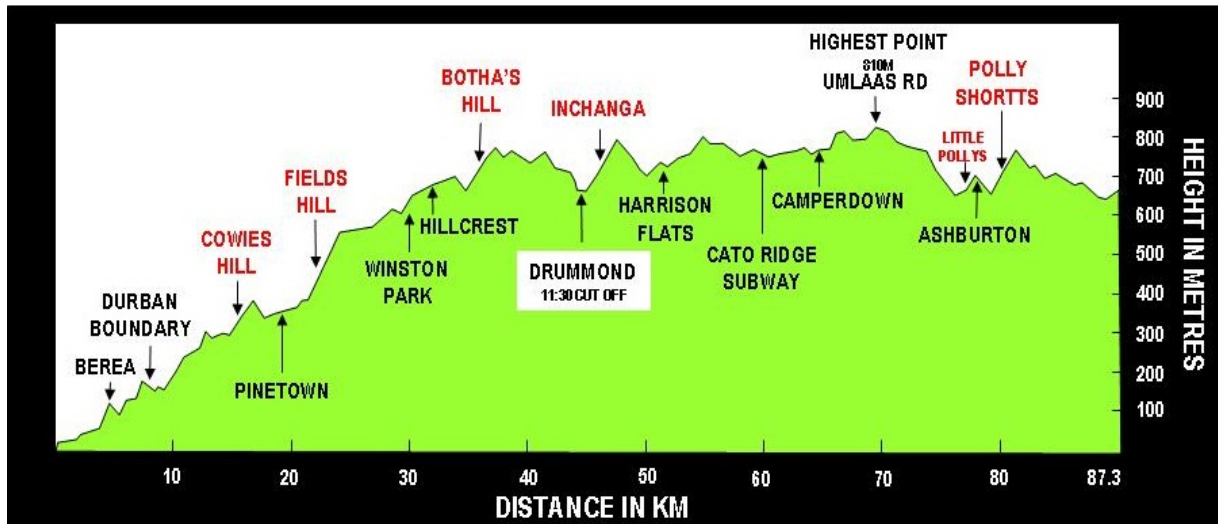

[Source: hambarobin.wordpress.com]

COMPASS CARDINAL POINTS FOR GENERAL DIRECTION

Maps usually include compass directions. Only the NORTH direction is shown in many cases. You are supposed to work out the other directions.

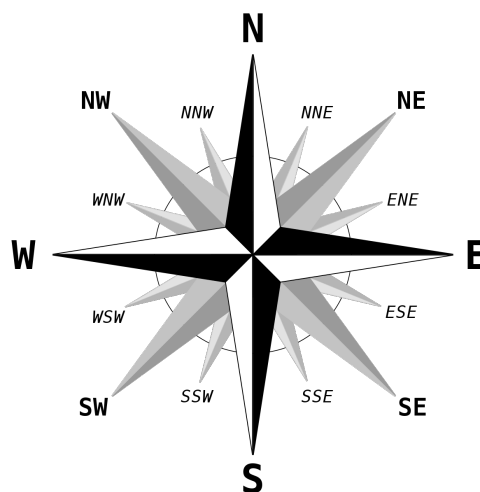

GIVING DIRECTIONS



go straight



turn right

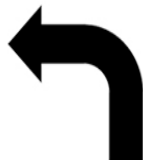

turn left



U turn



go past ...



cross



across from



next to



on/at the corner



take the first right



at the roundabout,
take the the first exit



ROAD SIGNBOARDS

The signboard gives a variety of information: Road names, names of suburbs and compass direction.



[Source: lenashsigns.co.za]



[source: alamy.com]

WORKED EXAMPLE

QUESTION 1

Mrs Tshabalala stays in Lesotho. She is planning to have a holiday in KwaZulu Natal. Below is the Map she will be using to decide on places to visit.

Map showing Regions of KwaZulu Natal

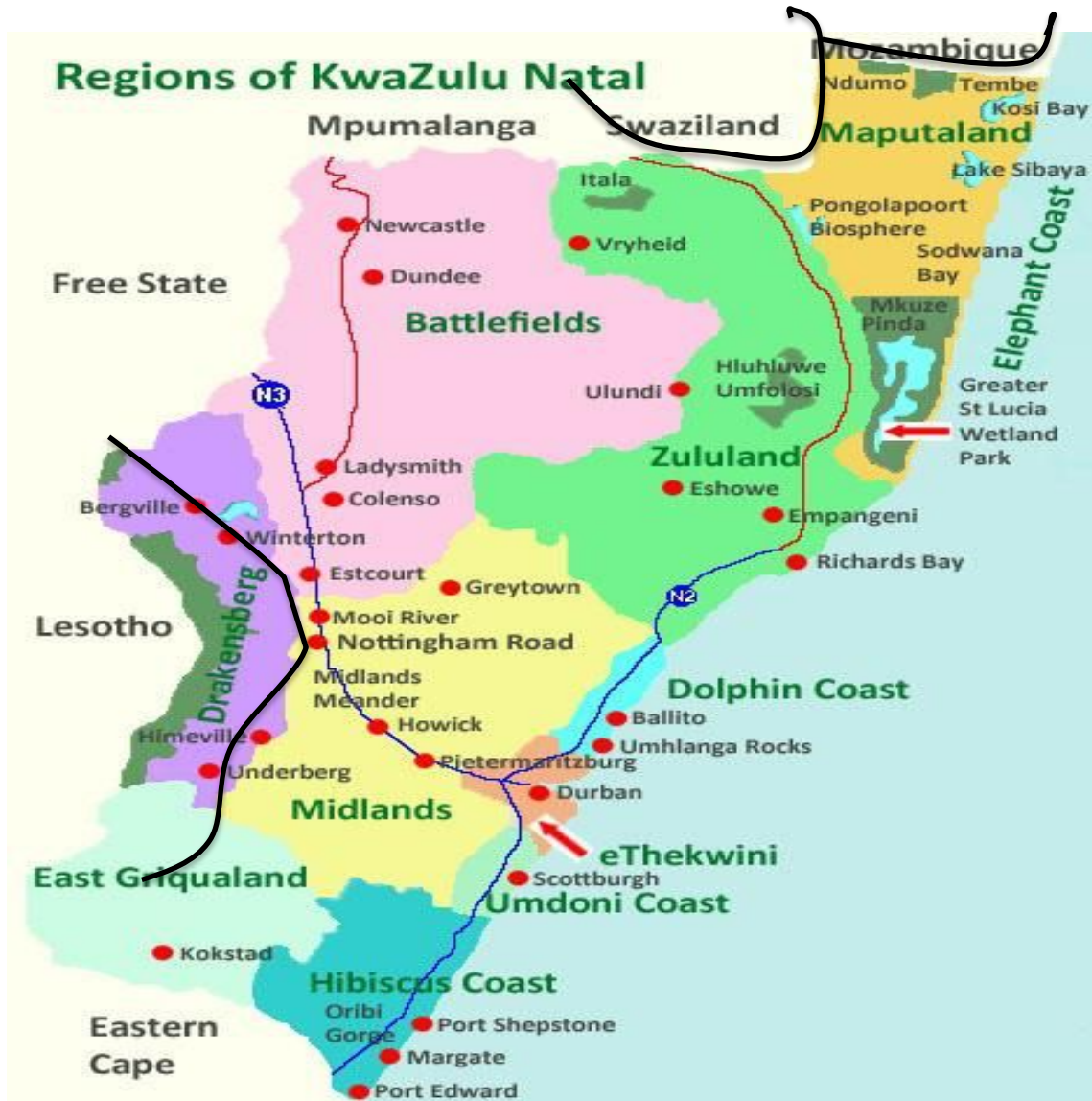

Source: www.maphill.com

N

Use the information above to answer the following questions.

- 1.1 How many National Road(s) is/are on the map?
- 1.2 Give the general direction of Ulundi from Lesotho.
- 1.3 Give the name of the province that is east of Lesotho.

- 1.4 The distance from Lesotho to Ulundi is 734 km. Mrs Tshabalala is driving at an average speed of 120km/h. How long will it take him to reach Ulundi? Leave your answer in hours and minutes.
You may use the following formula

$$\text{Average speed} = \frac{\text{distance (km)}}{\text{time (h)}}$$

- 1.5 Mrs Tshabalala will first go to Free State to pick her son. Her car's fuel consumption is 19.62 km per litre and the cost of petrol is R17.00 per litre.
- 1.5.1 Give clear set of directions for the Tshabalala's to get to Empangeni wh they plan to spend a day with a family friend before going to Ulundi.
- 1.5.2 How many litres of petrol will Mrs Tshabalala need for the return trip from Lesotho to Ulundi?
- 1.5.3 Hence calculate the amount of money that Mrs Tshabalala will need for petrol?
- 1.5.4 Give a reason why there is a bold line between Lesotho and South Africa?

NOTES

Solutions

1.1 2

1.2 North East OR NE

1.3 KwaZulu - Natal

1.4 $120 \text{ km} = \frac{734 \text{ km}}{\text{time (h)}}$
Time = 6.116666667h
Time = 6 hours + 0.116666667 × 60
∴ Time = 6h3.5min

- 1.5.1
- From Free State take South East of N3 till Pietermaritzburg
 - Pass Pietermaritzburg and turn North East of N2
 - Continue driving on N2 till you pass Richards Bay and Empangeni is on the left.

1.5.2 Number of litres = $\frac{734}{19.62}$
= 37.2 ℓ × 2
= 74.82 ℓ

1.5.3 Petrol Cost = 74.82 × 17.00
= R1 271.94

1.5.4 Border line

PRACTICE QUESTIONS

QUESTION 1

Amukele went to Namibia on holiday and used the map of Namibia Amukele went to Namibia on a that is given in below.

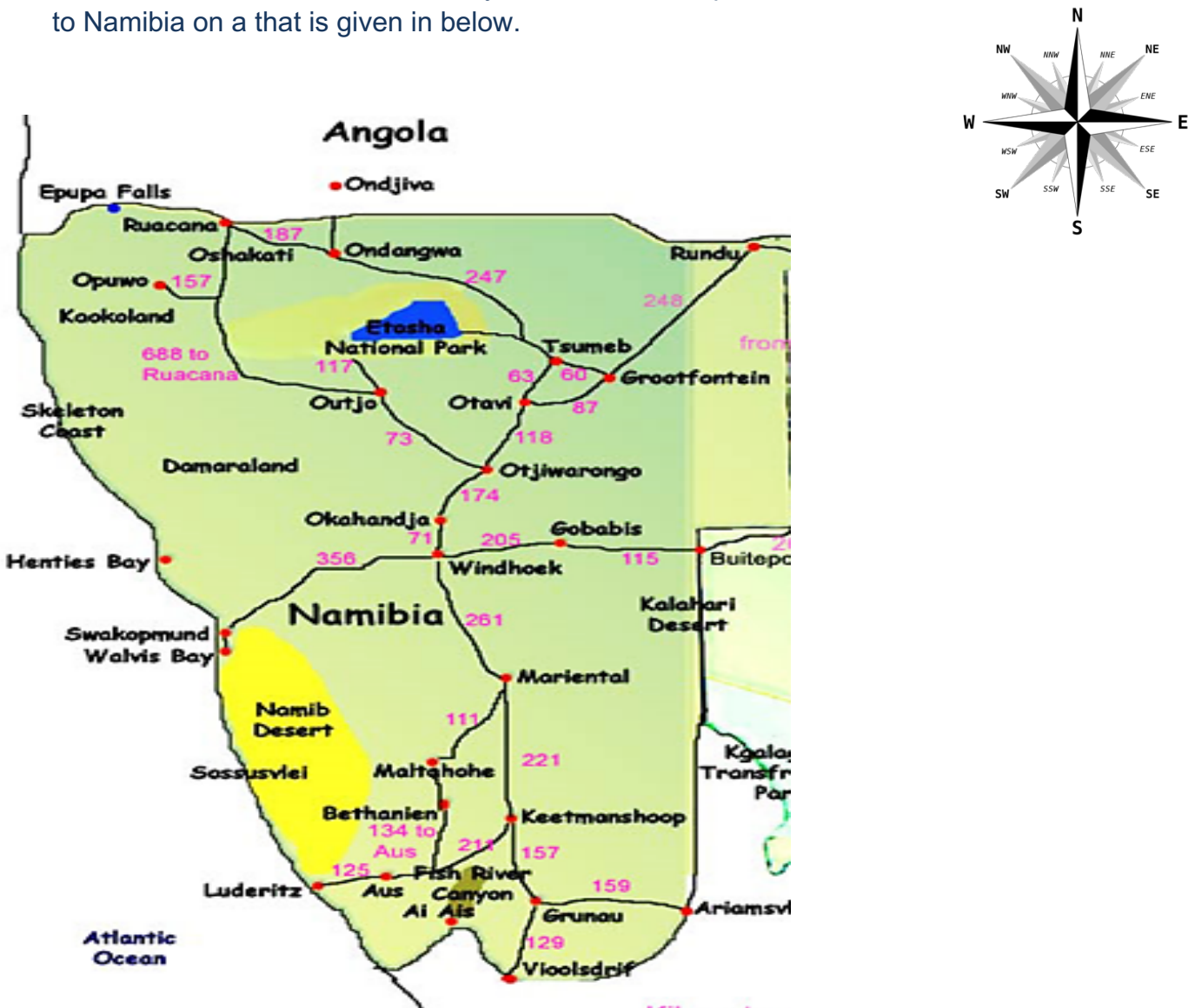

[Source:www.madbookings.com]

DISTANCE CHART

Swartkopmund				
297	Sesriem			
205	83	Solitaire		
552	745	684	Tsumeb	
31	266	205	673	Walvis Bay
356	319	258	426	389
				Windhoek

Use the Map above to answer the following questions.

- 1.1 Determine the general direction of Kalahari Desert from Vloosdrift. (2)
- 1.2 Use the distant chart to determine the distance between Swartkopmund and Walvis Bay. (2)
- 1.3 Consider the actual distance from Keetmanskoop to Windhoek. Measure the distance between the two places on the map. Hence calculate the number scale used to draw the map. (6)
- 1.4 Determine the actual distance from Gobabis to Grootfontain on the map. (3)
- 1.5 Amukele leaves Gobabis at 7:45 and travels at an average speed of 90 km/hour. He states that he will arrive in Grootfontein at 12 noon, if he travels at the same speed. Verify, using calculations if his timing is **CORRECT**. (6)

You may use the formula:

$$\text{Time} = \frac{\text{distance}}{\text{speed}}$$

- 1.6 Calculate the cost of petrol to travel from Gobabis to Grootfontein, if the car's petrol consumption is 8 litres per 100 km and petrol cost R16,45 per litre. (4)

NOTES

QUESTION 2

The strip map shows the distance from Cape Town to Port Elizabeth. Mpilenhle will be driving from Cape Town to Beaufort West. He drives a Mercedes-Benz C 63 AMG with a 70 litre fuel tank capacity and fuel consumption of 10,3l/100km.

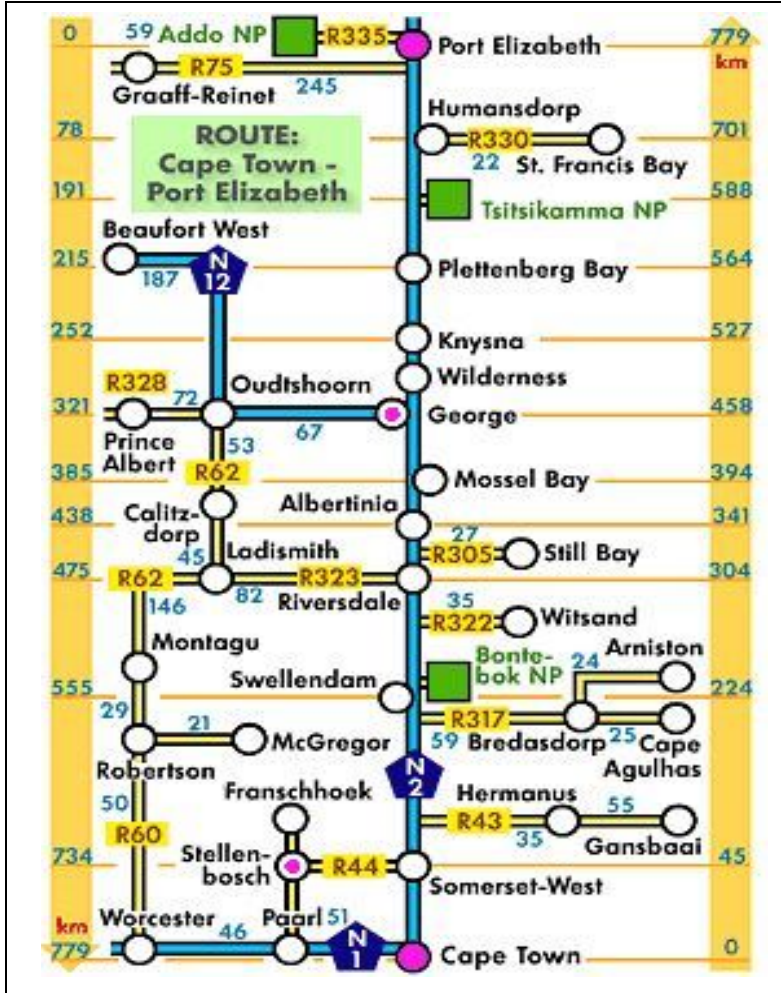

Source:[www.google.com]

Use the strip chart above to answer the following questions.

- 2.1 Describe the route, including the distance, Mpilenhle will follow. (3)
- 2.2 Calculate the total distance in 2.1 above. (2)
- 2.3 Use the given fuel consumption rate to advise Mpilenhle on the number of times he will need to refuel his car to get to his destination. (5)

QUESTION 3

The Big Five Marathon is an annual event in South Africa. It can be run as a full 42 km marathon or as a half-marathon of 21 km.

The race has specific cut-off times (certain compulsory distances to be covered within specific times). Runners who do not meet the cut-off times are forced to withdraw from the race.

Below are the cut-off times for the full marathon.

FULL MARATHON			
	CUT-OFF 1	CUT-OFF 2	CUT-OFF 3
Distance from start	25,5 km	31,5 km	Finish line
Time from start	4 hours 15 min	5 hours 15 min	7 hours

[Source: <http://aublog.southafrica>]

The ANNEXURE contains the Big Five 42 km full marathon map.

Use the information above and the ANNEXURE to answer the questions that follow.

- 3.1 Determine (as a decimal fraction) the probability of a runner of the Big Five marathon route accessing a refreshment station that offers ONLY Coke and water. (3)
- 3.2 Give the general direction in which a marathon runner is heading when passing the 20 km mark. (2)
- 3.3 Consider the heights above sea level for this race.
 - (a) Explain why a runner was CORRECT when he stated that he was running uphill from the start to the 10 km mark. (2)
 - (b) Express, in the form $1 : \dots$, the lowest possible height above sea level to the highest height above sea level. (3)

3.4 Explain why there are cut-off times for a marathon. (2)

3.5 For the half-marathon a runner must cover a distance of 16,5 km in a time of 5 hours from the start of the race to beat the cut-off 2 time for the half-marathon.

A runner of the full marathon compared his speed with the speed of a half-marathon runner and stated that he had to run 2,7 km/h faster in order to beat the cut-off 2 time of the full marathon.

Verify, showing ALL calculations, whether he is CORRECT.

You may use the formula:

Distance = speed × time (6)

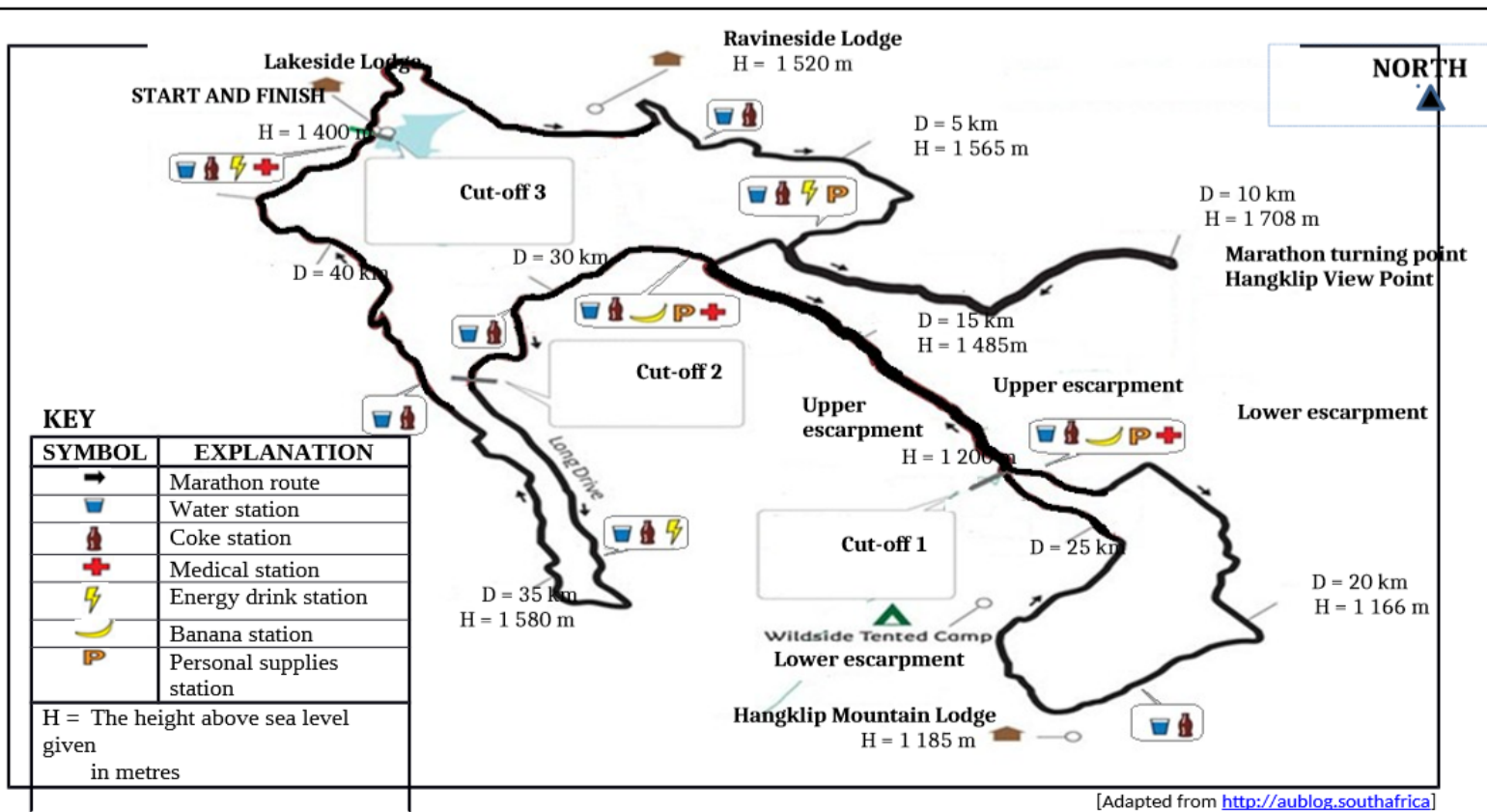

THE BIG FIVE 42 km FULL MARATHON MAP

Question 4

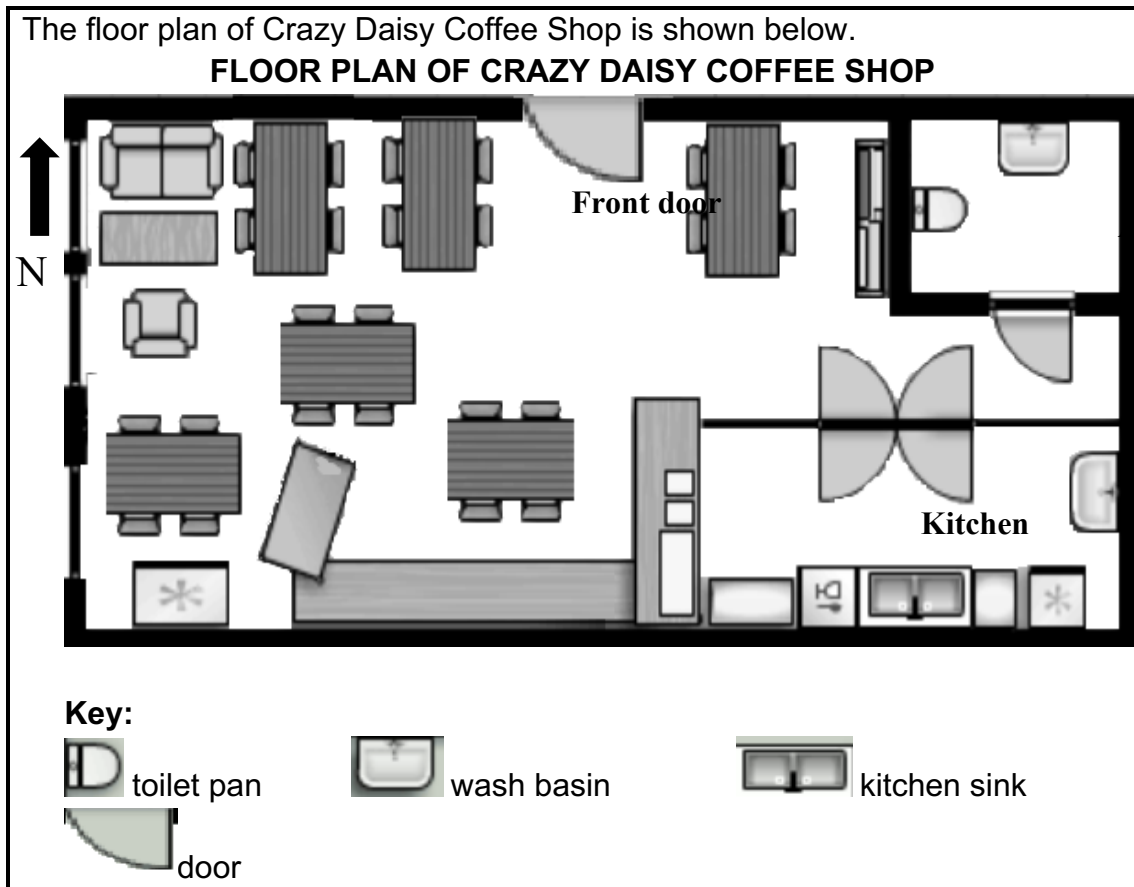

[Adapted from www.shopkeep.com]

Use the floor plan above to answer the questions that follow.

- 4.1 Explain the meaning of the term *floor plan* in this context (2)
- 4.2 Identify the room labelled **A**. (2)
- 4.3 Give the general direction of the kitchen from the front door. (2)
- 4.4 The measured width of the coffee shop is 70mm. The actual width is 15m. Determine the scale (rounded off to the nearest whole number) of the floor plan. (3)

3.1.4 PLANS (INSTRUCTION/ ASSEMBLY DIAGRAMS)

OBJECTIVES

By the end of this section learners must be able to:

- Use instruction / assembly diagrams, containing words and/or pictures.
- Complete the task completed in the instructions and/or explain what the instructions mean and/or represent
- Understand the symbols and notations used on plans
- Describe what is being presented on the plans
- Analyse the layout of the structure shown on the plan
- Determine actual length of objects shown on plans using measurements and a given scale
- Determine quantities of materials needed by using measurement and a given scale.
- Connect the features shown on elevation plans which features on perspectives shown on a floor of the same structure
- Determine how long /wide/high an object should be drawn on a plan when actual dimensions are known
- Draw scaled 2D floor and elevation plans

NOTES

SUMMARY

ASSEMBLY DIAGRAMS

- Show diagrams/pictures/nets of complete items
- They use symbols for the different components of an item.
- They have written instructions on how to put the different components together.

INSTRUCTION/ ASSEMBLY DIAGRAMS-UNASSEMBLED WOODEN FURNITURE UNIT

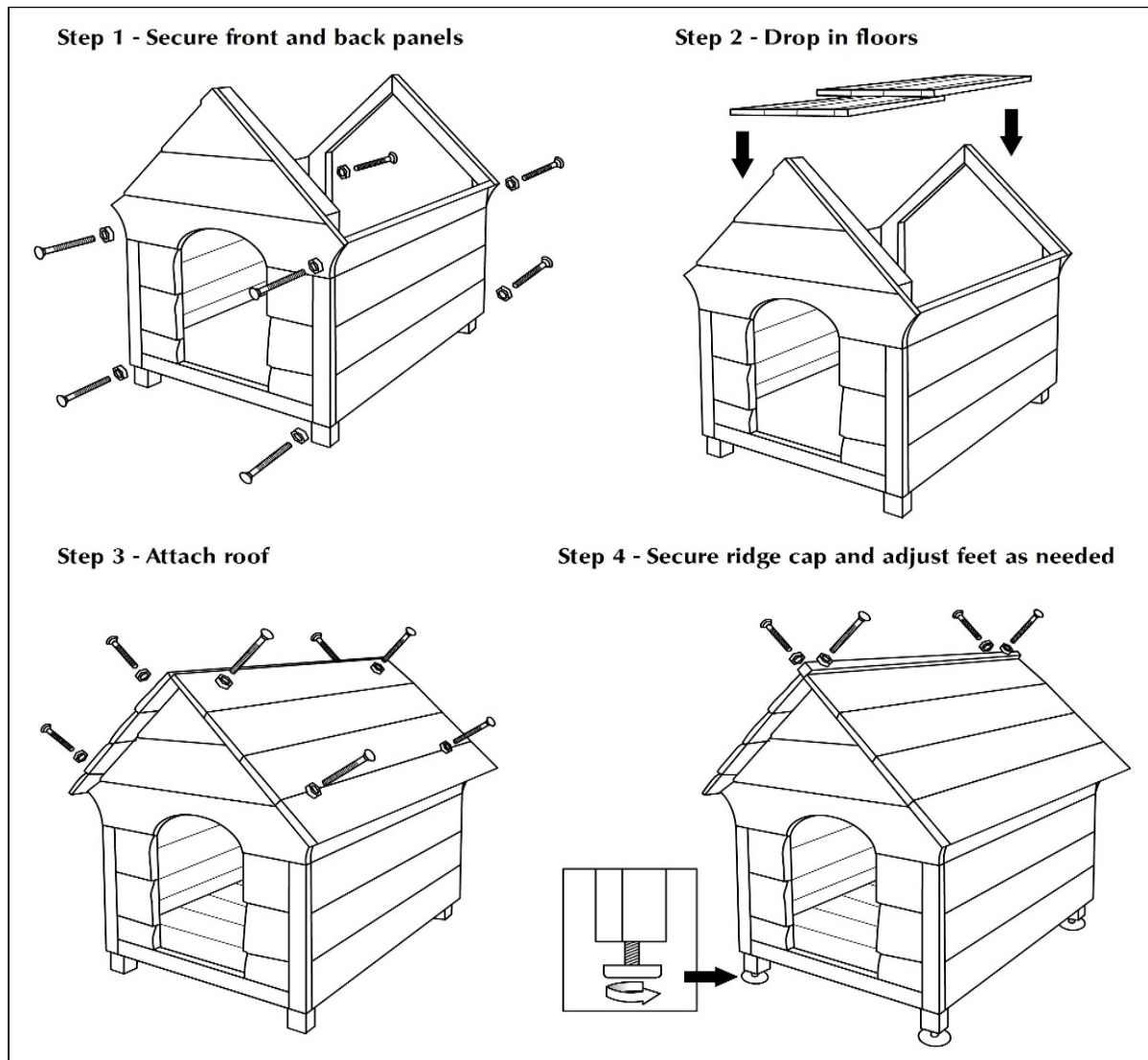

[Source: intl.siyavula.com]

INSTRUCTION/ ASSEMBLY DIAGRAMS =CELL-PHONE (INSTALLING A SIMCARD)

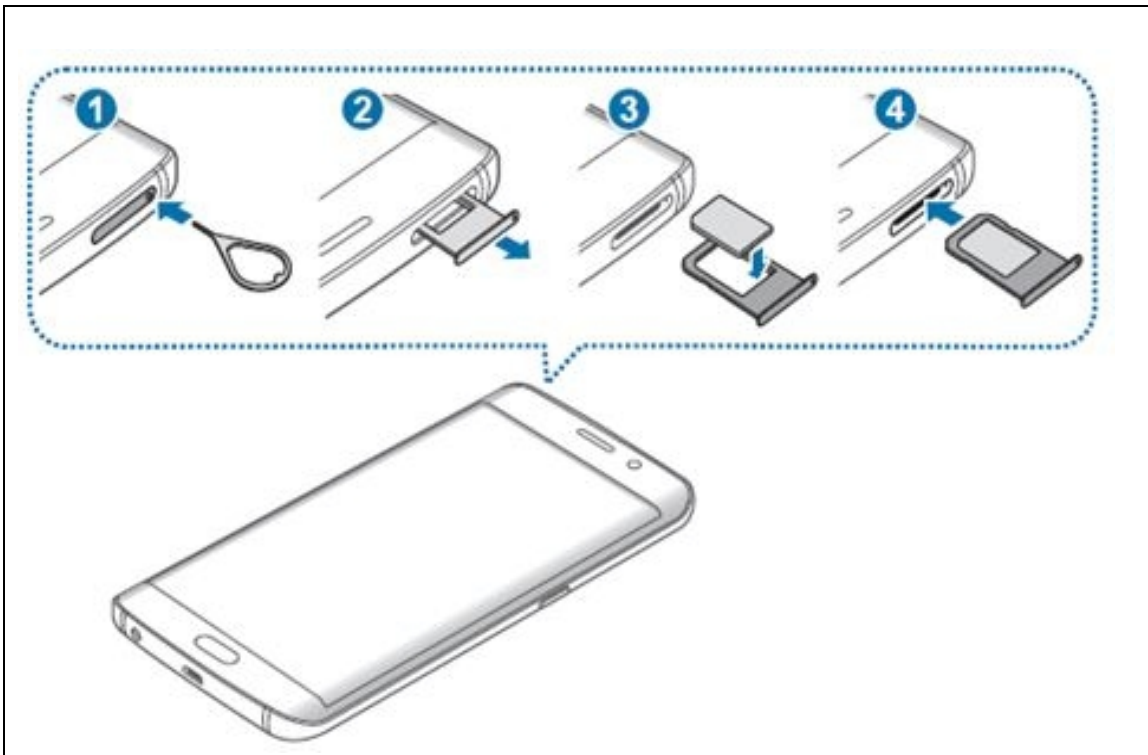

[source: samsung.com]

INSTRUCTION/ ASSEMBLY DIAGRAMS CHILDREN'S TOYS

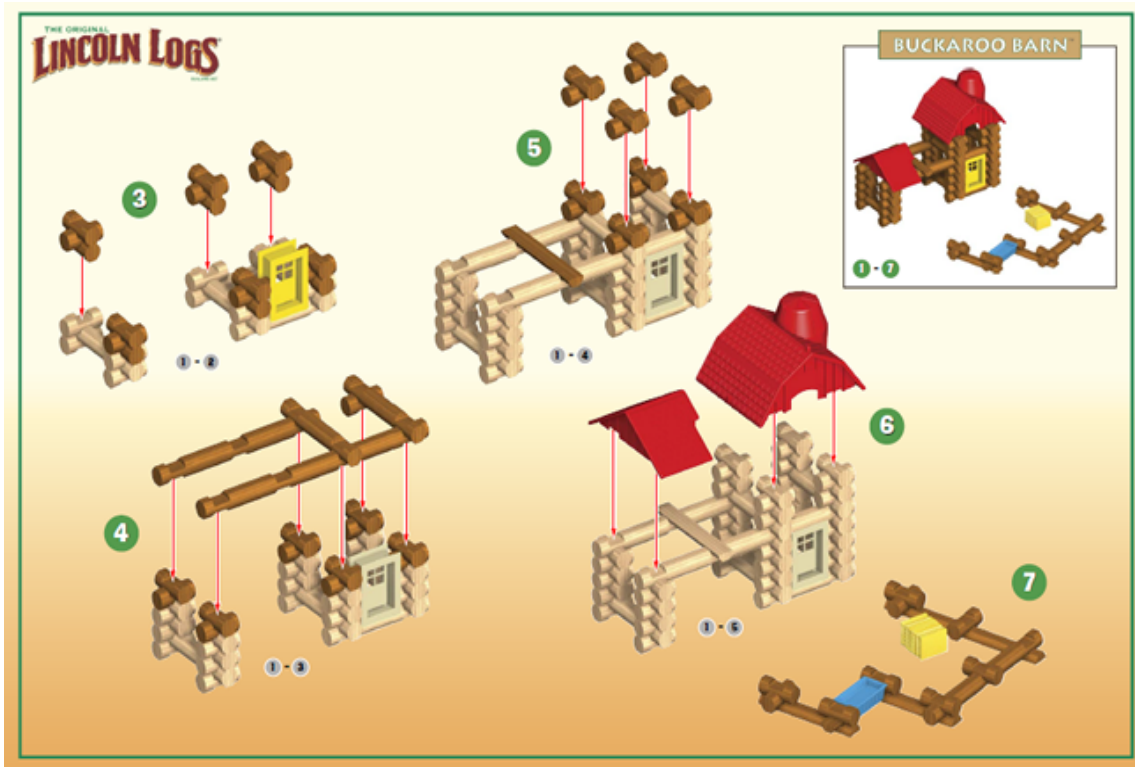

[source:techwhirl.com]

PLAN (FLOOR ELEVATION and DESIGN PLANS)

PLAN - FLOOR ELEVATION

- Shows a top view of a building (room, office, house, etc.) floor.
- Always drawn to a given scale.
- Includes length measurements.
- Uses standard symbols for building features such as door/window/garage openings, bathroom utilities, furniture, etc.
- May include compass direction indicators (North, South, East, West)

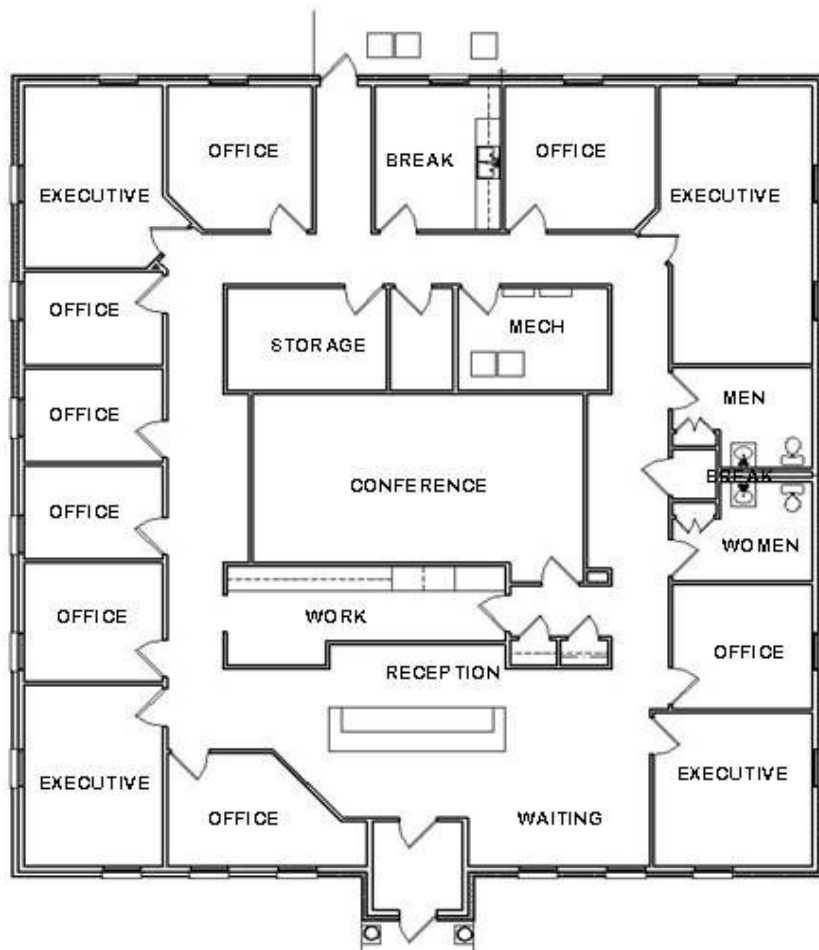

EXAMPLES OF THE SYMBOLS USED ON PLAN LAYOUT



Wall



Window



Window

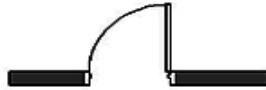

Door with its swing direction



Sliding Door



Door Placement



Toilet



Bath

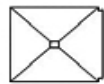

Shower



Sink

ELEVATION PLANS

- Shows the different side views of a building i.e. north/south/east/west side view or elevation.
- Gives a complete outside structure of a building.
- Always drawn to scale.
- Shows different wall features such as doors and windows.

PLAN-ELEVATION PLANS



[Source: za.pinterest.com]

WORKED EXAMPLES

QUESTION 1

The bowline is a knot that's used to form a fixed loop on the end of a rope. In sailing, it's commonly used to attach a line to the head of a sail. The picture below shows how to tie a bowline. The pictures are not in the correct order.

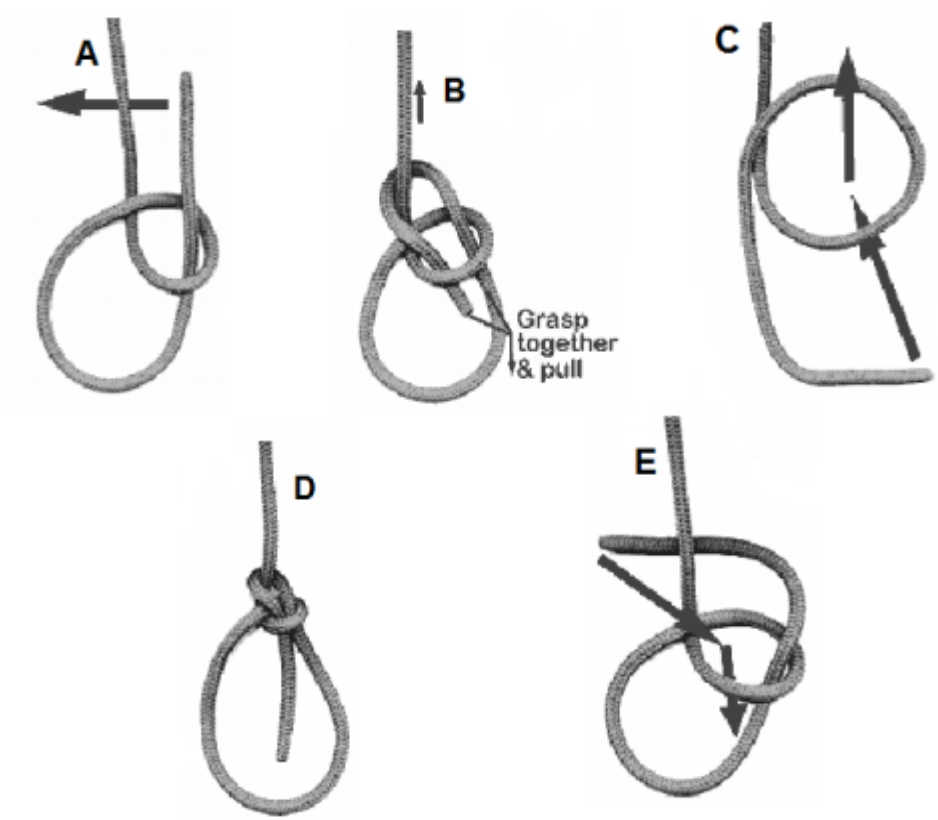

Arrange the pictures in the correct order.

SOLUTION

Quest	Answer
1	C;A;E;B;D

NOTES

Empty rectangular box for notes.

QUESTION 2

The diagrams below show a set of labelled assembly instructions (not in order of assembly) to build a toy car with Lego blocks.

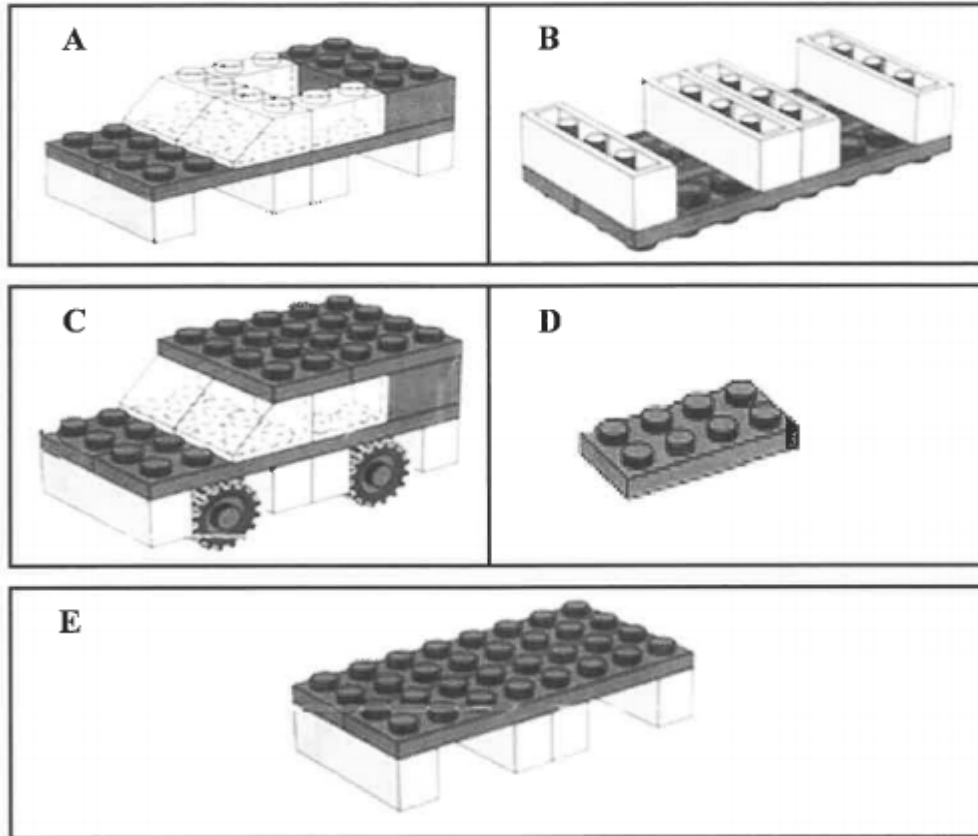

[Source: www.lego.com]

Study the diagrams above to answer the questions that follow.

- 2.1 Write down the correct order of the assembly instructions to build the toy car using the letters A, B, C, D and E.
- 2.2 Which letter (A, B, C, D or E) fits the instructions, 'Flip over the part-assembly?'
- 2.3 A can of Lego blocks contains 20 red blocks, 25 blue blocks, 28 green blocks, 30 black blocks and 27 white blocks.
A block is randomly selected from the can.
Determine the probability that the block will be the following:
 - (a) Yellow
 - (b) Blue

SOLUTIONS

QUESTION 3

RDP houses are built with bricks to assist low income people with proper houses. They have pitch roofs with the area of 51,8 m². Study this floor plan and answer the question below it.

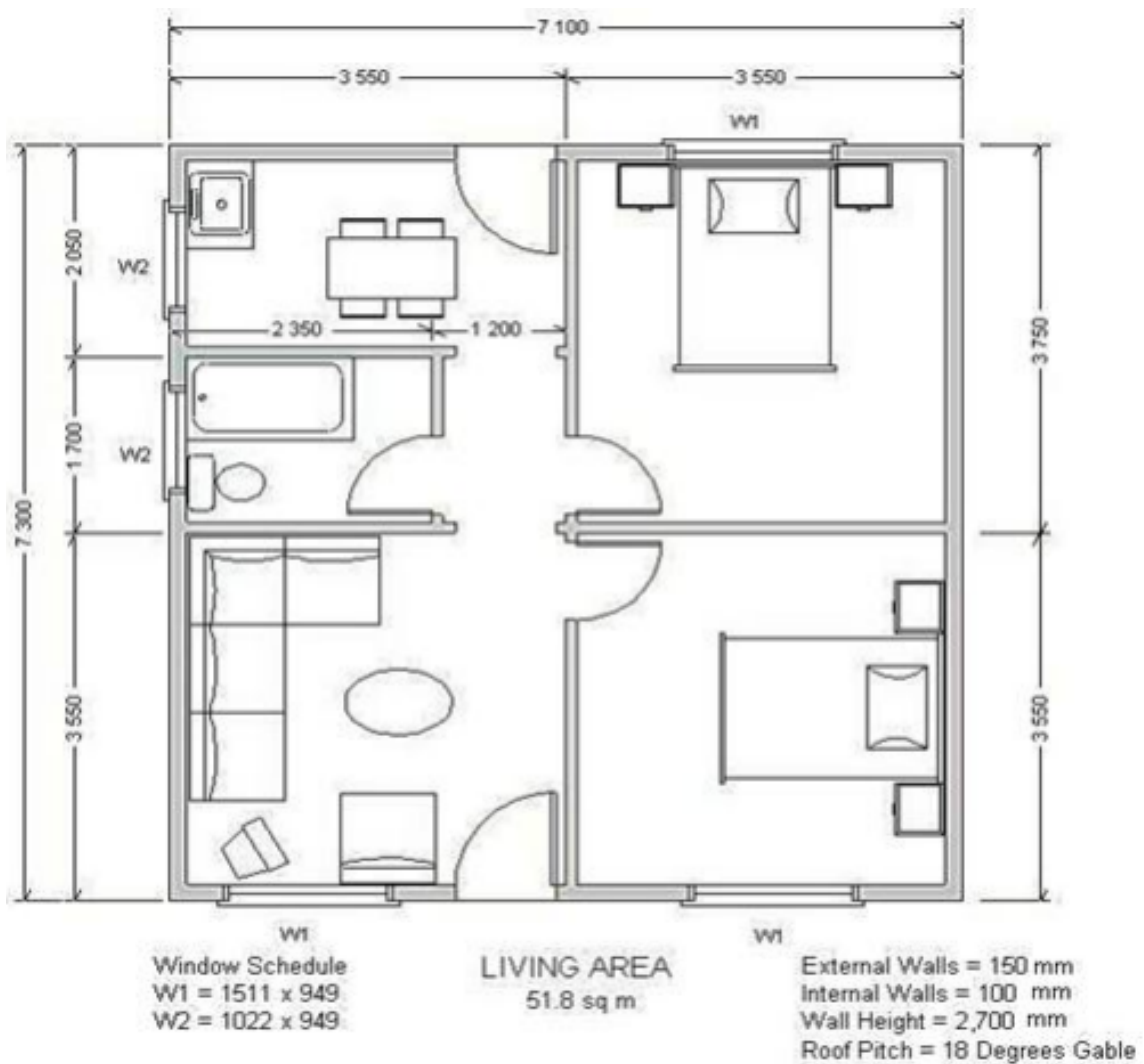

[Source: moladi.com/Lightweight-Construction-Method.htm]

- 3.1 How many doors are shown on the plan?
- 3.2 How many windows are shown on the plan?
- 3.3 To which side does the kitchen door open?
- 3.4 How many roof tile will be needed to cover the roof if 10 roof tiles cover 1m^2 .
- 3.5 How many roof tile will be needed to cover the roof if 10 roof tiles cover 1m^2 .

SOLUTIONS

Que	Answer
3.1	Elevation plan is a cross-section plan from different directions or side of a building
3.2	5
3.3	5
3.4	left
3.5	$51,8 \times 10$ $= 518$

PRACTICE QUESTIONS

QUESTION 1

1.1 Zoleka bought herself a cellphone. She wants to insert her SIM card into the phone and have to follow the instructions as shown in the illustrations below.

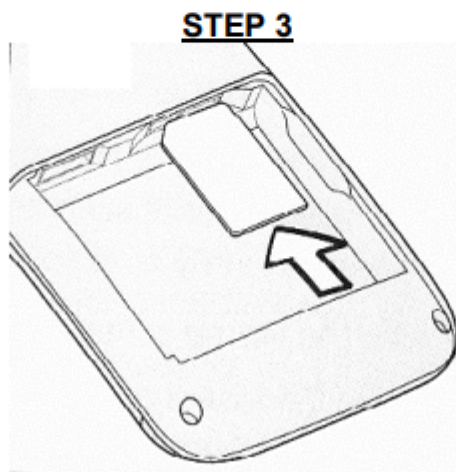
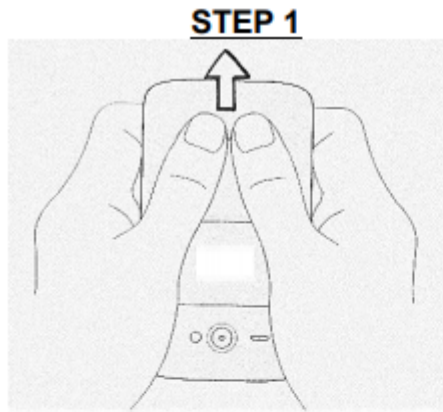

Briefly explain the steps that Zoleka needs to take to insert the SIM card (6)

1.2 Study the second last stage of assembling a learner's desk below and answer the questions that follow

SECOND LAST STAGE OF ASSEMBLING THE SCHOOL DESK

(6)

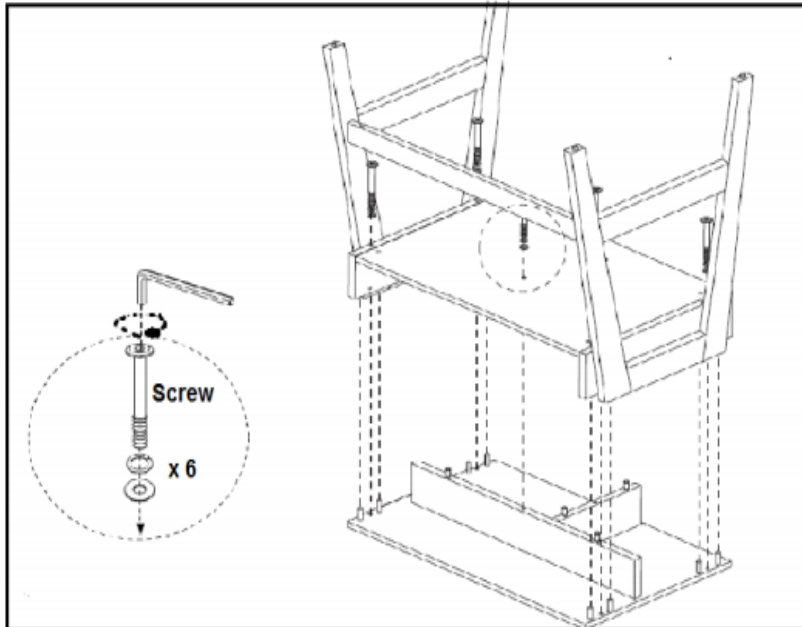

1.2.1 Determine the number of screws needed to fix two of these school desks (2)

1.2.2 The direction in which the screw is tightened. Is it clockwise or anticlockwise. (2)

QUESTION 2

Mr and Mrs Swart retired recently. They intend to move to a complex for senior citizens which is still in a developmental stage. They were provided with several floor plans from which they could choose the type of house which may fit their lifestyle. They were allowed to suggest a reorganisation of the inside layout, but the exterior walls must remain as shown on the plan. Use the plans and information provided below to answer the questions that follow.

(Take note – diagrams are not necessarily drawn to scale)

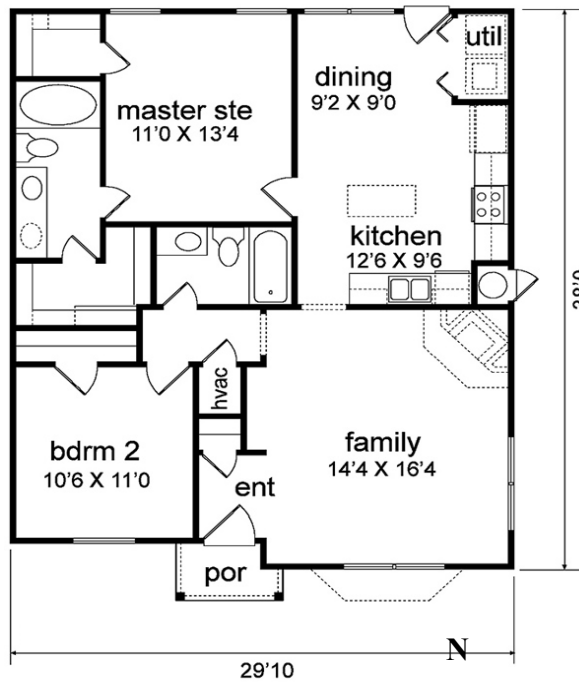

B-Elevation



C-Elevation

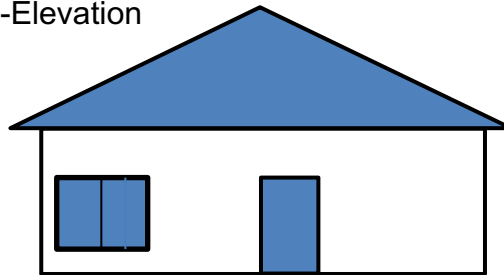

A -Elevation

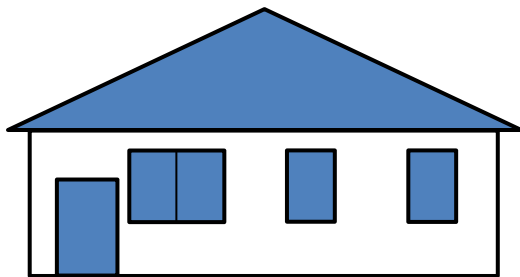

D-Elevation

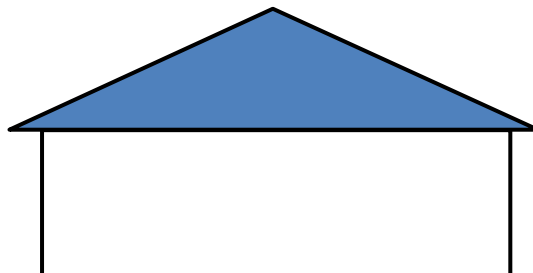

- 2.1 Explain which rooms in the plan will be warmer than the others during the winter months, if no heating equipment is switched on. Substantiate your answer(s). (2)
- 2.2 Use a compass direction to appropriately replace the C in “C – Elevation”. (3)
- 2.3 Name the rooms without windows on this plan. Discuss any challenge that an occupant of the building may experience due to the lack of windows. (2)
- 2.4 Explain one layout change that you will make to this house if you were buying the house. Substantiate your suggested change. (4)

Note: A change without justification will not be awarded marks.

NOTES

QUESTION 3

Jane and Tom are the newly-weds. They plan to build a house using the floor plan and elevations shown below.

FLOOR PLAN WITH ELEVATIONS

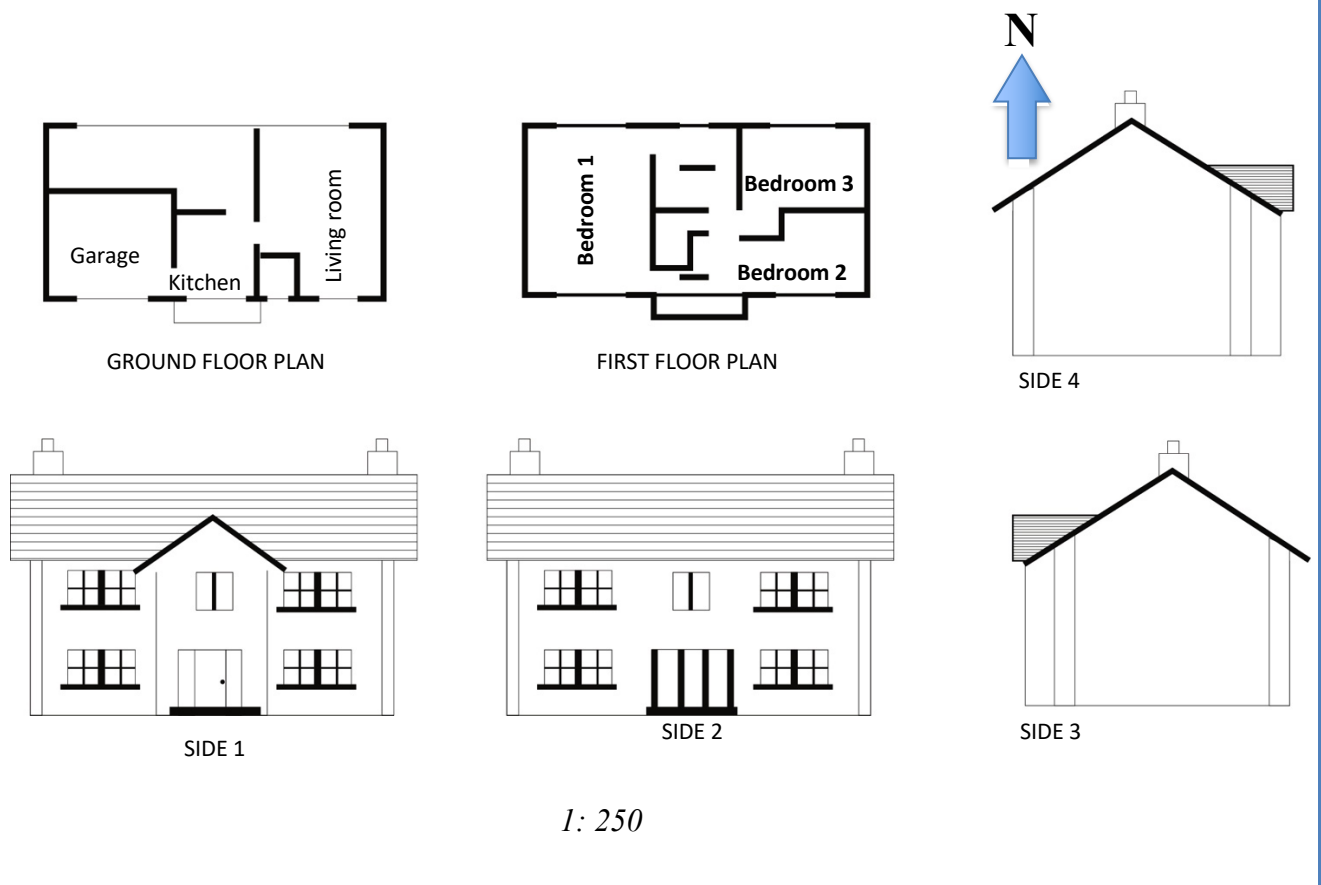

Source: www.floorplans.com

Use the information above to *answer* the questions that follow.

3.1 How many bedrooms are shown on the floor plan? (2)

3.2 The elevations are numbered from 1 to 4. Match the elevation with the correct number e.g. West elevation 3.

- (a) North elevation
 - (b) South elevation
 - (c) West elevation
 - (d) East elevation
- (4)

3.3 Is this plan for a single or double storey house? (2)

3.4 Draw a symbol that represents a door for floor elevation? (2)

3.1.5 MODELS

Objectives

By the end of this section learners must be able to:

- Determine the most appropriate way to package can/or optimum use of space
- Determine the most cost-effective way to package a number of cans and/or boxes
- Investigate the best packaging shape for packaging a particular product.
- Investigate the best packaging shape to use for fragile and irregular shaped objects.
- Investigate the amount of material used to make a box.
- Investigate the number of furniture items that can fit into a venue.
- Estimate quantities of materials needed.
- Investigate possible ways to stack/arrange boxes in a storeroom in order to maximise wasted space.
- Critique aspect of the layout and/or design of a structure and make suggestions for alterations
- Investigate the placement of furniture in a room

SUMMARY

- Show diagrams/nets of packaging containers for various shapes.
- Show diagrams/nets of packaging arrangements of various containers or items.

MODELS (PACAKGING IN 2DIMENSIONAL SCALE)



MODELS (PACAKGING IN 3 DIMENSIONAL SCALE)



WORKED EXAMPLES

QUESTION 1

Petru buys rectangular boxes with reels of thread for stitching stockings. The radius of a cylindrical reel is 11,5 mm.

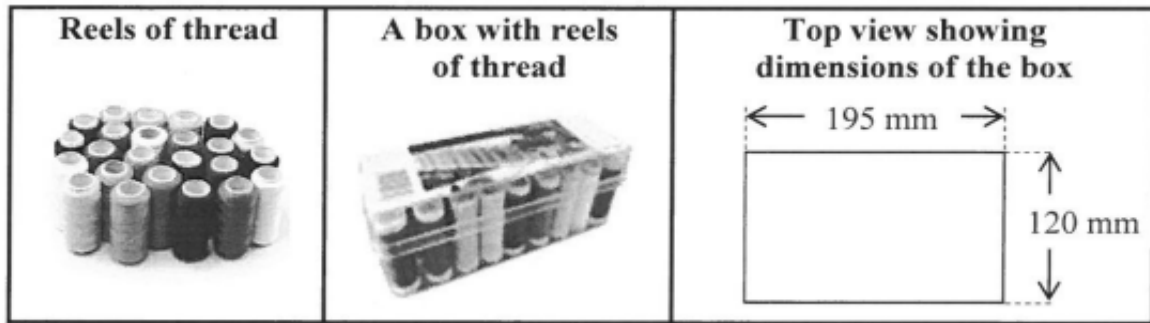

Determine the maximum number of reels of thread that will fit exactly into a rectangular box that is 120 mm wide and 195 mm long. Show ALL calculations

Question 1

Que	Solution
	$\begin{aligned} \text{Number of reels along length} &= 195\text{mm} \div 23\text{mm} \\ &= 8,4782\dots \\ &= 8 \end{aligned}$
	$\begin{aligned} \text{Number of reels along breadth} &= 120\text{ mm} \div 23\text{ mm} \\ &= 5,2173\dots \\ &= 5 \end{aligned}$
	$\text{Total} = 5 \times 8 = 40$

Question 2

Determine the maximum number of cylindrical spice bottles that can be put in the rack if the packaging length is 50,5 cm

You may use the formula:

Number of bottles packed = Packaging length ÷ diameter of bottle

Question 2

Que	Solution
	$\begin{aligned} \text{Number of bottles packed} &= \text{Packaging length} \div \text{diameter of bottle} \\ &= \frac{50,5}{4,4} \\ &= 11,48 \\ &= 11 \end{aligned}$

PRACTICE QUESTIONS

QUESTION 1

In a Creative Arts classroom, the teacher keeps coloured pencils in three identical cylindrical containers. These pencils remain unsharpened until they are used or lost. Below is a diagram that shows the cylindrical container. (Diagram not drawn to scale)

The height of the container is 18 cm and the diameter is 79 mm

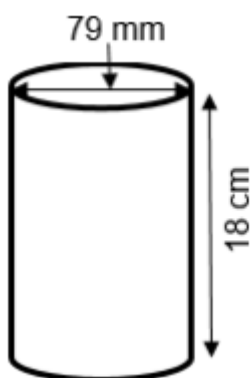

- 1.1 If the diameter of one coloured pencil is 7mm and the length 17,5 cm, calculate how many coloured pencils can fit into the three containers. (8)
- 1.2 The teacher packs some of the coloured pencils as follows in each of the containers; 3 red, 2 blue, 2 green and 3 orange. Calculate the probability that if a pencil is taken from all containers it will be a red pencil. Write your answer as a percentage. (3)

QUESTION 2

5 litre paint are packed in shop for delivery in big rectangular boxes. An example of these boxes are shown below. The diagrams are not drawn to scale.

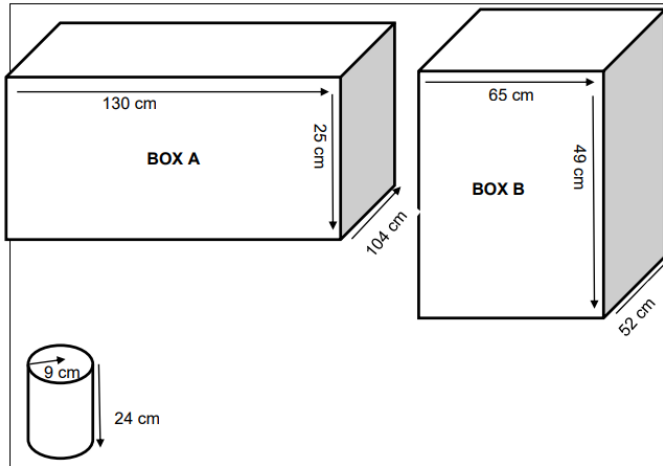

There are two rectangular boxes and their dimensions are as follows:

Dimensions of Box A

Length = 130 cm
Width = 104 cm
Height = 25 cm

Dimensions of Box B
Height = 25 cm
Length = 130 cm
Width = 104 cm

Dimensions of 5litre paint tin
Radius = 9cm
Height = 24 cm

2.1 The packers argue that if they use Box A for packaging the paint tins, they will be able to pack more than two time the paint tins in Box B.

Use calculations to prove if their argument is valid or not (6)

2.2 A truck carrying 20 boxes of box B with 5 litre paint tins has an accident and all the paint is spilt. How much in Rand will be lost.

NB. 5 litre paint costs R185, 95 (4)

3.2 SOLUTIONS TO PRACTICE QUESTIONS

3.2.1 SCALE

QUE	SOLUTION	EXPLANATION	L
1.	Scale is 1 : 500 $= 15 \text{ cm} \times 500 \checkmark M$ $= 7\,500 \text{ cm}$ $= 75 \text{ m} \checkmark M$	1M Multiplying by scale 1M Converting from cm to m (2)	L2
2.	$\text{Actual distance} = \frac{\text{Distance on the map} \times \text{Scale}}{\text{Conversion}}$ $\text{Actual Distance} = \frac{180 \times 500 \checkmark SF}{1000 \checkmark C}$ $= 90 \text{ m} \checkmark A$	1SF substitution 1C conversion 1A answer (3)	L2
3.	$2 \text{ cm} = 22 \text{ m} \checkmark M$ $11 \text{ cm} = a$ $\frac{242}{2} = \frac{2a}{2} \checkmark M$ $121 = a$ Therefore $2 \text{ cm} = 121 \text{ m} \checkmark CA$	1M Measuring the scale 1M Dividing and Multiplying by the scale 1CA Answer (3)	L3

MAPS

Question 1			
QUE	Answers	Explanation	level
1.1	North East ✓✓RM	2RM reading from map (2)	L2
1.2	31km ✓✓RM	2RM reading from chart (2)	L2
1.3	<p>Measure distance = 4cm ✓M Distance = 221+261 ✓MA = 482 km</p> <p>Number Scale: 4cm = 482 km ✓M 4cm = 48 200 000cm ✓C 1cm = 12 050 000cm ✓M 1:1 2050 000 ✓CA</p>	<p>Accept 1mm leeway 1M measuring distance 1MA adding distance</p> <p>1M concept of scale 1C multiplying by 100 000 1M dividing by 4 1CA simplification (6)</p>	L3
1.4	Total distance = 205 + 71 + 174 + 118 + 87 ✓✓RM = 655 km ✓A	1A total distance (3)	L2
1.5	<p>Time = $\frac{655}{90}$ ✓SF = 7,277777778</p> <p>Minutes = 0,277777778 × 60 ✓C = 16,67 = 17 ✓CA</p> <p>Total time = 7 hours 17 minutes ✓CA</p> <p>Time at Destination = 7:45 + 7 hours 17 mins ✓M = 15:02</p> <p>Statement is incorrect ✓O</p>	<p>1SF substitution</p> <p>1C conversion</p> <p>1CA minutes</p> <p>1CA time in hours and minutes</p> <p>1M adding</p> <p>1O explanation (6)</p>	L4

	<p>Number of litres = $(655 \div 100) \times 8$ ✓MA = 52,4 litres ✓CA</p> <p>Cost of Petrol = $52,4 \times R16,45$ ✓M = R861,98 ✓CA</p>	<p>1MA multiply by 8 divide by 100 1CA litres</p> <p>1M multiply by R16,45 1CA cost of petrol (4)</p>	L3

3.2.3 PLANS

QUESTION 1

QUE	Answers	Explanation	level
1.1	<p><u>Step 1</u></p> <p>With the thumbs push the cover out to remove the battery ✓✓A</p> <p><u>Step 2</u></p> <p>Take the battery out ✓✓A</p> <p><u>Step 3</u></p> <p>With the battery compartment open and the battery removed, insert the SIM card into the slot with gold plate facing down ✓✓A</p>	<p>2A step 1 explanation</p> <p>2A step 1 explanation</p> <p>2A step 1 explanation</p>	L4
1.2.1	12 ✓✓A	2 A Answer	L1
1.2.2	Clockwise ✓✓A	2 A Answer	L1

QUESTION 2

QUE	Answer	Explanation	level
2.1	The master bedroom and the ✓A dining room/ kitchen area ✓A They face North, ✓J hence in winter the sun will fall into those rooms and heat them ✓J	1A master bedroom 1A dining/ kitchen 1J North facing 1J Heat from the sun	L4
2.2	Eastern OR East ✓✓A	2A Correct directions	L2
2.3	None of the bathroom have windows The dressing rooms/ rooms linked to the bathrooms ✓✓RD A person will have to switch a light on when entering the room- increases elcrticity consumption ✓J OR In a bathroom one cannot open a window to assist to get rid of the steam ✓J OR Any well motivated explanation ✓J	2RD – Identify rooms without windows 1J – Provide a real life challenge	L4
2.4	Bathrooms placement reposition the second bathroom to face an outside wall in order to put in windows. ✓O✓J OR Swop bathroom 2 with dressing room to install windows in both bathrooms ✓O✓J OR Make changes to get the entrance of both bedrooms from the family room section Prefer that the main bedroom entrance should not be from kitchen-food smells ✓O✓J OR Accept any practical layout with motivation ✓O✓J	1O Identify a change 1J Justify the change	L4

QUESTION 3

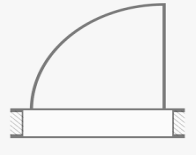
QUES	Answer	Explanation	level
3.1	3 bedrooms ✓ ✓A	2A correct number (2)	L1
3.2	(a) North elevation – 2 ✓A (b) South Elevation – 1 ✓A (c) West Elevation – 4 ✓A (d) East elevation - 3 ✓A	4A correct numbers (4)	L2
3.3	Double storey ✓ ✓A	2A Answer (2)	L2
3.4	 ✓ ✓A	2A Drawing (2)	L2

3.2.4 MODELS

QUESTION 1

QUE	Solution	Explanation	level
1.1	<p>Number of coloured pencils across $= 79\text{mm} \div 7\text{mm} \checkmark\text{M}$ $= 11,28571429 \checkmark\text{CA}$ $= 11 \text{ pencils } \checkmark\text{R}$</p> <p>Number of pencils down $= 18 \text{ cm} \div 17,5 \text{ cm} \checkmark\text{M}$ $= 1,028571429$ $= 1 \checkmark\text{R}$</p> <p>Total number of pencils in one container $= 11 \times 1$ $= 11 \checkmark\text{CA}$</p> <p>Total number of pencils in 3 containers $= 11 \times 3 \checkmark\text{M}$ $= 33 \checkmark\text{CA}$</p>	<p>1M Dividing by diameter 1CA Answer 1R Rounding down number of pencils</p> <p>1M Dividing by height 1R Rounding down number of pencils</p> <p>1CA number of pencils</p> <p>1M multiply by 3 1CA Answer</p>	L3
1.2	<p>Probability $= \frac{9}{33} \checkmark\checkmark\text{AA}$</p> <p>$= \frac{9}{33} \times 100\%$</p> <p>$= 27,27\% \checkmark\text{CA}$</p>	<p>CA from 1.1 1A numerator 1A denominator</p> <p>1CA Answer as a percentage</p>	L2

QUESTION 2

QUE	Solution	Explanation	level
2.1	<p>5 litre tins Radius = 9cm Diameter = 18 cm</p> <p>Box A: Number of tins across the length of the box: $= 130 \div 18$ $= 7, 222\dots$ $= 7 \checkmark M$</p> <p>Number of tins over the height of the box: $= 25 \div 24$ $= 1, 04$ $= 1 \checkmark M$</p> <p>Number of tins across the width of the box: $= 104 \div 18$ $= 5, 77$ $= 5 \checkmark M$</p> <p>Total tins for box A $= 7 \times 1 \times 5$ $= 35 \checkmark CA$</p> <p>BOX B: Number of tins across the length of the box: $= 49 \div 24$ $= 2, 04\dots$ $= 2$</p> <p>Number of tins over the height of the box: $= 52 \div 18$ $= 2, 88$ $= 2$</p>	<p>1M number of tins across length</p> <p>1M number of tins over height</p> <p>1M number of tins across width</p> <p>1CA total number of tins in Box A</p>	<p>MP L3</p>

	<p>Number of tins across the width of the box: $= 65 \div 18$ $= 3.6$ $= 3$</p> <p>Total tins for box B $= 3 \times 2 \times 2$ $= 12 \checkmark$CA</p> <p>Box A can carry 35 tins which is more than 2 times 12 so their argument is valid \checkmarkO</p>	<p>1CA total number of boxes in Box B</p> <p>1O Comparing</p>	
--	---	---	--

4. EXAMINATION GUIDANCE

PAPER 2	
Weighting of topics	Maps, plans and other representation of the physical world 40% ((±5) Measurement 55% (±5) Probability 5% Including ±5% (Income, Expenditure, Profit/loss, Income-and-Expenditure statements and Budgets, Cost price and Selling price) where there is direct link to Measurement and Maps and Plans.
Structure and scope of content and/or skills	<p>Question 1: 30 marks ± 5 marks Level 1 questions from Measurement and Maps, plans</p> <p>Question 2 'Maps and plans</p> <p>Question 3 Measurement</p> <p>Question 4 Integrated context on 'Measurement and Maps and plans Including (Income, Expenditure, Profit/loss, Income-and-Expenditure statements and Budgets, Cost price and Selling price) where there is direct link to Measurement and Maps and Plans.</p> <p>Question 5 Measurement, maps and plans or integration Data handling will be examined in the context of one or more of the other questions. Each question can contain more than one context.</p>
NOTE : The paper may have 4 or 5 questions	

WEIGHTING

Topics	PAPER 2	%	150 marks	TAXONOMY LEVELS		
Measurement		55 %	83**		Level 1: Knowing	30% (±45 marks)
Maps & plans		40%	60**		Level 2: Applying routine procedures in familiar contexts	20% (±30 marks)
Probability		5%	7		Level 3: Applying multi-step procedures in a variety of contexts	20% (±30 marks)
<i>Finance**</i>		±5%	8-15**		Level 4: Reasoning and reflecting	30% (±45 marks)
TOTAL		100%	150 marks		Level 1: Knowing	30% (±45 marks)

****NOTE:**

- Section in Finance: (Income, Expenditure, Profit/loss, Income-and-Expenditure statements and Budgets, Cost price and selling price) can be included in Paper 2 where there is direct link to Measurement and Maps and Plans.

Time and mark allocation**Paper 2**

Duration	Marks
3 hours	150 Marks

Time management for Examination preparation:

If you have 100 hours to prepare for the examination, the following can be used as a guide on how to use your hours:

Application Topics	Number of hours
Measurement	55
Maps, Plans and Other...	40
Probability	5

Order of the questions in the question paper

Each paper may have 4 or 5 questions.

Paper 2:

QUESTION 1 (30 marks \pm 5 marks ONLY taxonomy Level 1.) Short context – mixed questions (Maps and Plans and Measurement.)

QUESTION 2 – Maps and Plans

QUESTION 3 – Measurement

QUESTION 4 – Maps and Plans and Measurement

QUESTION 5 – Maps and Plans, Measurement or integrated

Probability will be integrated in all five questions, where it is appropriate

Question 4 and 5 may include financial calculations as pertains to problem solving in Maps and Plans and Measurement.

GUIDANCE

Set a goal (marks you would like to see on your Matric Certificate) at the beginning of the term, If for example your aim is to achieve 60% for Mathematical Literacy.

One way of getting it is as follows:

Paper 1: 90 marks out of a possible 150

Paper 2: 90 out of a possible 150

A total of 180 out of 300 = 60%

5. GENERAL EXAMINATION TIPS

1. Study the matric timetable. Know when you are going to write the papers you have registered for. There are sometimes two exams on one day so you will have to be super sharp and alert. **Be sure to check the final timetable in case there are any changes.**
2. There are less than 123 days to the start of the final exams. This includes all weekends and holidays. Start today and work every day. Set targets for achievement.
3. Do not miss **one day of studying** between now and your exams. Work at least two to three hours per day. Keep healthy and alert.
4. **Reading** is a hot skill. Reading will change your life. Read at least 1000 words every day. Read everything you can get your hands on. Read accurately and quickly.
5. **Writing** is power, but it requires practice. We are all judged, every day, on our writing. We can inspire, impress, persuade, congratulate and express love in writing. Write at least 400 words every day carefully, accurately and beautifully.
6. **Resources** are an essential student companion. Work systematically through your question papers and Self Study Guide. Don't wait for your face-to-face classes or broadcasts to explain it all. Look at what you have to cover for the subject and plan accordingly.
7. Your **BMI** can help you in matric. Your Body mass Index (BMI) is an indication of how healthy you are. Calculate your BMI and then exercise and eat healthy throughout the year to keep an optimum BMI.
8. Academic work requires **concentration and focus**. Every day you should be engaged in intensive, focused, individual academic work. Turn off iPods, music centres, the TV, the cell phone and have an intensive and rewarding academic work out every day. Except of course if you are using it to access the resources. Be diligent and don't be tempted to watch or access non – academic material. Technology is a fabulous platform to learn and prepare for the examinations but it can also be a deterrent if you are not focused and dedicated. Build your brain cells and be the envy of all your friends.
9. Good vibes are good for success. Surround yourself with positive people who want you to succeed. Your family and friends will be important in supporting you in the next 123 days. Be grateful for their support.
10. Matric success requires **Planning and hard work**. Start planning and working today. Read every day. Write and calculate every day. Stick to your year plan.



6. REFERENCES

1.	DBE Mathematical Literacy Book 1 Grade 12.
2.	DBE Mathematical Literacy Book 2 Grade 12.
3.	DBE Mathematical Literacy Book 3 Grade 12.
4.	DBE Mathematical Literacy Paper 1 November 2017
5.	DBE Mathematical Literacy Paper 2 November 2018
6.	DBE Mathematical Literacy Paper 1 May - June 2018
7.	DBE Mathematical Literacy Paper 1 May - June 2019
8.	DBE Second Chance Matric Support Programme
9.	Eastern Cape Mathematical Literacy Grade 11 Paper 2 November 2013
10.	Eastern Cape Mathematical Literacy Grade 12 Paper 1 September 2014
11.	Eastern Cape Mathematical Literacy Grade 11 Paper 2 November 2016
12.	Eastern Cape Mathematical Literacy Grade 12 Paper 2 June 2017
13.	Eastern Cape Mathematical Literacy Grade 11 Paper 1 November 2017
14.	Gauteng Mathematical Literacy Grade 12 Paper 2 September 2015
15.	KwaZulu Natal Mathematical Literacy Grade 12 September 2020.
16.	Mathematical Literacy Answer Series Grade 12
17.	Mathematical Literacy Bright Ideas
18.	Mathematical Literacy Mind The Gap
19.	Mpumalanga Mathematical Literacy Grade 12 Paper 1 September 2018
20.	Western Cape Mathematical Literacy Grade 12 Paper 1 September 2014
21.	Western Cape Mathematical Literacy Grade 12 Paper 1 September 2017
22.	Western Mathematical Literacy Cape Grade 12 Paper 2 September 2017

7. ACKNOWLEDGEMENTS

The Mathematical Literacy Second Chance Self Study Guide Booklet was developed by the following Subject Specialist:

- Ms Arden Ellie (Eastern Cape Education Department)
- Ms Thembeke Nethe (Free State Education Department)
- Mr Nzimeni Koba (Free State Education Department)
- Mr Peter Kekana (Gauteng Education Department)
- Mrs Zandile Mdiniso (KwaZulu – Natal Education Department)
- Ms Mary Sebela (Limpopo Education Department)
- Mr Kwazinkosi Gwate (Northern Cape Education Department)

The Department of Basic Education (DBE) gratefully acknowledges these officials for giving up their valuable time, families and knowledge to develop this resource for the children of our country.

It was also reviewed by the following Subject Specialist:

- Ms Luleka Nombombo (Eastern Cape Education Department)
- Dr Reinet van der Merwe ((Free State Education Department)
- Ms Nikiwe Zulu (Gauteng Education Department)
- Ms Lorraine Govender (KwaZulu – Natal Education Department)
- Ms Saloshni Pillai (KwaZulu – Natal Education Department)

A special mention must be made to Ms Masirheni Gladys Nkwini, the DBE curriculum specialist who, in addition to her contribution to the development of the booklet, co-ordinated and finalised the process.

The development of the Study Guide was managed and coordinated by Ms Cheryl Weston and Dr Sandy Malapile

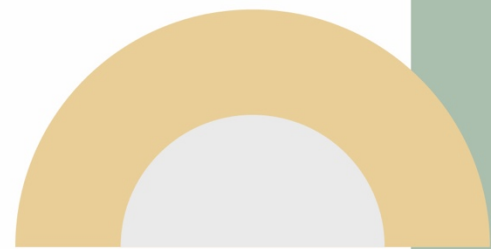
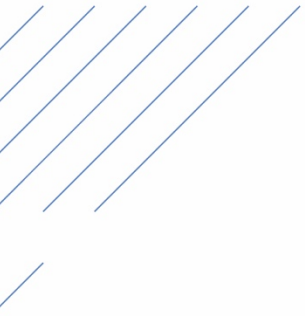
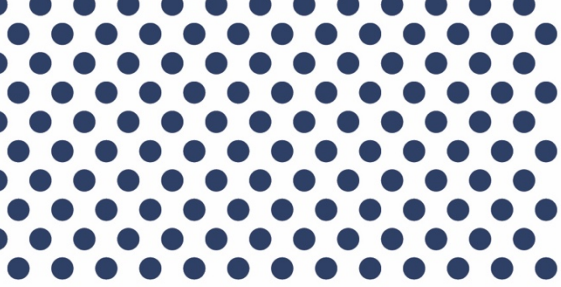

basic education

Department:
Basic Education
REPUBLIC OF SOUTH AFRICA

ISBN : 978-1-4315-3510-1

High Enrolment Self Study Guide Series

This publication is not for sale.

© Copyright Department of Basic Education

www.education.gov.za | Call Centre 0800 202 993