

# Learn Xtra



**LIFE SCIENCES**  
**GRADE 12**

**exam school**  
**2012**

The Department of Basic Education proudly endorses  
the Mindset Learn Spring School programme



**basic education**

Department:  
Basic Education  
**REPUBLIC OF SOUTH AFRICA**

Mindset Learn Xtra Exam School  
is brought to you by





## CONTENTS

Introduction .....	2
Broadcast Schedule .....	3
Preparing for Examinations .....	4
Exam Techniques .....	5
Life Sciences Exam Overview.....	6
Plant Responses to the Environment.....	7
Animal Responses to the Environment.....	11
Reproduction.....	16
Human Reproduction .....	22
Population Ecology .....	31
Community Structure and Change.....	39
Solutions to Plant Responses to the Environment.....	45
Solutions to Animal Responses to the Environment .....	46
Solutions to Reproduction.....	48
Solutions to Human Reproduction .....	50
Solutions to Population Ecology.....	52
Solutions to Community Structure and Change .....	56



## INTRODUCTION

Have you heard about Mindset? Mindset Network, a South African non-profit organisation, was founded in 2002. We develop and distribute quality and contextually relevant educational resources for use in the schooling, health and vocational sectors. We distribute our materials through various technology platforms like TV broadcasts, the Internet ([www.mindset.co.za/learn](http://www.mindset.co.za/learn)) and on DVDs. The materials are made available in video, print and in computer-based multimedia formats.

At Mindset we are committed to innovation. In the last three years, we have successfully run a series of broadcast events leading up to and in support of the Grade 12 NSC examinations

Now we are proud to announce our 2012 edition of Exam School. From 15<sup>th</sup> October till 20<sup>th</sup> November will bring you revision lessons in nine subjects - Mathematics, Physical Sciences, Life Sciences, Mathematical Literacy, English 1<sup>st</sup> Additional Language, Accounting, Geography, Economics and Business Studies.

In this exam revision programme we have selected Questions mainly from the Nov 2011 Papers and have tried to cover as many topics as we can. Each topic is about an hour long and if you work through the selected questions you will certainly have increased confidence to face your exams. In addition to the topics and questions in this booklet, we have schedule 1½ hour live shows a day or two before you write your exams. To get the most out of these shows, we need you to participate by emailing us questions, calling in or posting on twitter, peptxt or facebook.

Since you asked us for late night study sessions and that's what we've planned! You'll find repeats of our Live shows at 10:30pm every evening. Then from midnight to 6:00 am there are revision lessons too. So if you can't watch during the day, you can record or watch early in the morning! .

## GETTING THE MOST FROM EXAM SCHOOL

You must read this booklet! You'll find the exam overviews and lots of study tips and hints here. in Start your final revision by working through the questions for a topic fully without looking up the solutions. If you get stuck and can't complete the answer don't panic. Make a note of any questions you have. Now you are ready to watch a Learn Xtra session. When watching the session, compare the approach you took to what the teacher does. Don't just copy the answers down but take note of the method used. Also make a habit of marking your work by checking the memo. Remember, there are usually more than one way to answer a question.If you still don't understand post your question on Facebook – you'll get help from all the other Mindsetters on the page. You can also send an email to [helpdesk@learnxtra.co.za](mailto:helpdesk@learnxtra.co.za) and we'll get back to you within 48 hours.

Make sure you keep this booklet. You can re-do the questions you did not get totally correct and mark your own work. Exam preparation requires motivation and discipline, so try to stay positive, even when the work appears to be difficult. Every little bit of studying, revision and exam practice will pay off. You may benefit from working with a friend or a small study group, as long as everyone is as committed as you are.



We are pleased to announce that we'll continue to run our special radio broadcasts on community radio stations in Limpopo, Eastern Cape and KZN. This programme is called MTN Learn. Find out more details at [www.mtnlearning.co.za](http://www.mtnlearning.co.za). You can also listen online or download radio broadcasts of previous shows. Tuning into radio will give you the chance to learn extra! Look out for additional notes in Newspaper supplements too.

Mindset believes that the 2012 Learn Xtra Spring School will help you achieve the results you want. All the best to the Class of 2012!

## CONTACT US

We want to hear from you. So let us have your specific questions or just tell us what you think through any of the following:



LearnXtra



[helpdesk@learnxtra.co.za](mailto:helpdesk@learnxtra.co.za)



@learnxtra



086 105 8262



[www.learnxtra.co.za](http://www.learnxtra.co.za)



Mindset

Get the free app at [pepclub.mobi](http://pepclub.mobi)

## BROADCAST SCHEDULE

### Exam School (Dstv and Toptv 319)

Time	Sat 10 November	Sun 11 November
09:00	<i>Plant Responses to the Environment</i>	<i>Reproduction</i>
10:00	<i>Animal Responses to the Environment</i>	<i>Human Reproduction</i>
11:00	<i>Population Ecology</i>	<i>Plant Responses to the Environment</i>
12:00	<i>Community structure &amp; change</i>	<i>Animal Responses to the Environment</i>
13:00	<i>Lunch Break</i>	<i>Lunch Break</i>
13:30	<i>Reproduction</i>	<i>Population Ecology</i>
14:30	<i>Human Reproduction</i>	<i>Community structure &amp; change</i>
15:30	<i>Live: Reproduction (Repeat Spring School)</i>	<i>Live</i>
17:00	<i>Plant Responses to the Environment</i>	<i>Animal Responses to the Environment</i>
18:00	<i>Animal Responses to the Environment</i>	<i>Plant Responses to the Environment</i>
22:30	<i>Live (Repeat)</i>	<i>Live: (Repeat)</i>
24:00	<i>Plant Responses to the Environment</i>	<i>Population Ecology</i>
01:00	<i>Animal Responses to the Environment</i>	<i>Community structure &amp; change</i>
02:00	<i>Population Ecology</i>	<i>Reproduction</i>
03:00	<i>Community structure &amp; change</i>	<i>Human Reproduction</i>
04:00	<i>Reproduction</i>	<i>Plant Responses to the Environment</i>
05:00	<i>Human Reproduction</i>	<i>Animal Responses to the Environment</i>



## PREPARING FOR EXAMINATIONS

1. Prepare well in advance for all your papers and subjects. You need to start your planning for success in the final examination now. You cannot guarantee success if you only study the night before an exam.
2. Write down the date of your prelim and final exam so that you can plan and structure a study time table for all your subjects.
3. Set up a study time-table according to your prelim and final Grade 12 exam time-table and stick to your study schedule. If you study a small section every day, you will feel you have achieved something and you will not be as nervous by the time you have to go and write your first paper.
4. Your study programme should be realistic. You need to spend no more than 2 hours per day on one topic. Do not try to fit too much into one session. When you cover small sections of work often, you will master them more quickly. The broadcast schedule may help you to make sure you have covered all the topics that are in the exam.
5. When studying don't just read through your notes or textbook. You need to be active by making summary checklists or mind maps. Highlight the important facts that you need to memorise. You may need to write out definitions and formulae a few times to make sure you can remember these. Check yourself as often as you can. You may find it useful to say the definitions out aloud.
6. Practise questions from previous examination papers. Follow these steps for using previous exam papers effectively:
  - Take careful note of all instructions - these do not usually change.
  - Try to answer the questions without looking at your notes or the solutions.
  - Time yourself. You need to make sure that you complete a question in time. To work out the time you have, multiply the marks for a question by total time and then divide by the total number of marks. In most exams you need to work at a rate of about 1 mark per minute.
  - Check your working against the memo. If you don't understand the answer given, contact the Learn Xtra Help desk (email: [helpdesk@learnxtra.co.za](mailto:helpdesk@learnxtra.co.za)).
  - If you did not get the question right, try it again after a few days.
7. Preparing for, and writing examinations is stressful. You need to try and stay healthy by making sure you maintain a healthy lifestyle. Here are some guidelines to follow:
  - Eat regular small meals including breakfast. Include fruit, fresh vegetables, salad and protein in your diet.
  - Drink lots of water while studying to prevent dehydration.
  - Plan to exercise regularly. Do not sit for more than two hours without stretching or taking a short walk.
  - Make sure you develop good sleeping habits. Do not try to work through the night before an exam. Plan to get at least 6 hours sleep every night.



## EXAM TECHNIQUES

1. Make sure you have the correct equipment required for each subject. You need to have at least one spare pen and pencil. It is also a good idea to put new batteries in your calculator before you start your prelims or have a spare battery in your stationery bag.
2. Make sure you get to the exam venue early - don't be late.
3. While waiting to go into the exam venue, don't try to cram or do last minute revision. Try not to discuss the exam with your friends. This may just make you more nervous or confused.
4. Here are some tips as to what to do when you receive your question papers: Don't panic, because you have prepared well.
  - You are always given reading time before you start writing. Use this time to take note of the instructions and to plan how you will answer the questions. You can answer questions in any order.
  - Time management is crucial. You have to make sure that you answer all questions. Make notes on your question paper to plan the order for answering questions and the time you have allocated to each one.
  - It is a good idea always to underline the key words of a question to make sure you answer it correctly.
  - Make sure you look any diagrams and graph carefully when reading the question. Make sure you check the special answer sheet too.
  - When you start answering your paper, it is important to read every question twice to make sure you understand what to do. Many marks are lost because learners misunderstand questions and then answer incorrectly.
  - Look at the mark allocation to guide you in answering the question.
  - When you start writing make sure you number your answers exactly as they are in the questions.
  - Make sure you use the special answer sheet to answer selected questions.
  - Think carefully before you start writing. It is better to write an answer once and do it correctly than to waste time rewriting answers.
  - DO NOT use correction fluid (Tippex) because you may forget to write in the correct answer while you are waiting for the fluid to dry. Rather scratch out a wrong answer lightly with pencil or pen and rewrite the correct answer.
  - Check your work. There is usually enough time to finish exam papers and it helps to look over your answers. You might just pick up a calculation, language or a spelling error. In Life Sciences make sure that all graphs and diagrams have headings and are labelled correctly.





## LIFE SCIENCES EXAM OVERVIEW

### STRUCTURE OF LIFE SCIENCES EXAM PAPERS

#### Section A

**50 marks**

Short answer questions which could include one word answers, multiple choice and matching column type questions.

#### Section B

**60 marks**

Two questions of 30 marks each, divided into 3-4 sub-sections

#### Section C

**40 marks**

Data Response questions

20 marks

Mini-essay

20 marks

#### Life Sciences Paper 1

**Total Marks: 150**

**3 hours**

#### Life at molecular, cellular and tissue level

**±90 marks**

- DNA-the code of life and RNA
- Genetics & Genetic Engineering

#### Diversity, change and continuity

**±60 marks**

Evolution

#### Life Sciences Paper 2

**Total Marks: 150**

**3 hours**

#### Life Processes in plants and animals

**±90 marks**

- Plant responses to the environment
- Animal responses to the environment
- Human endocrine system
- Temperature regulation
- Reproduction
- Human Reproduction

#### Population and community ecology

**±60 marks**

- Population ecology
- Community Structure
- Community change over time



## PLANT RESPONSES TO THE ENVIRONMENT

### Question 1 (Adapted from Exemplar 2011, P2, Question 2.3.1 - 2.3.5)

A group of Grade 12 learners wanted to investigate the effect of light coming from one direction on the growth of shoots. They planted some wheat seeds in two seed trays and allowed it to germinate. When young shoots appeared above the soil level, the shoots were exposed to light from all directions for three days. After three days, the trays received different treatments as follows:

Tray A: The shoots were exposed to light from all directions.

Tray B: The shoots were exposed to light from one direction only.

The diagrams below show the effects of these treatments. Study it and answer the questions that follow.

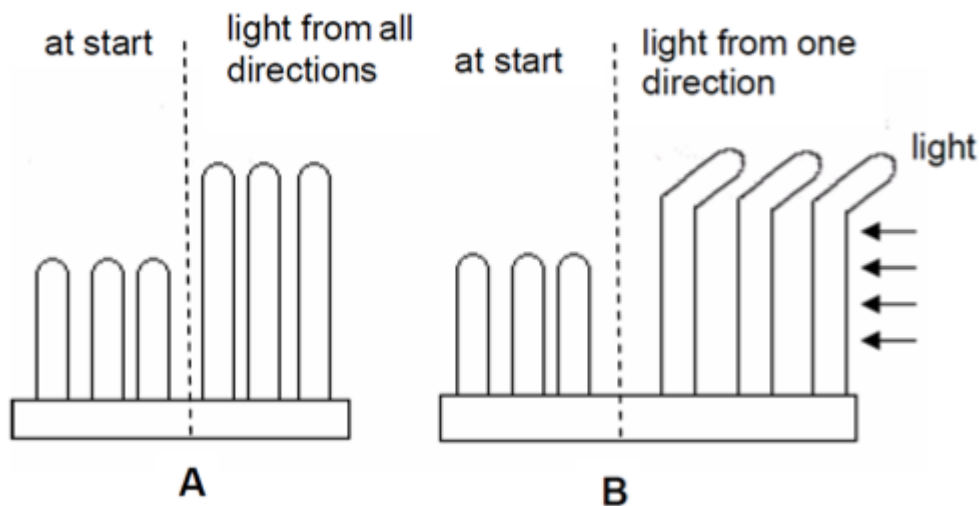

- 1.1 Formulate a hypothesis for the investigation above.
- 1.2 Explain why it was important to include tray A as part of this investigation.
- 1.3 State ONE conclusion that may be drawn from this investigation.





A third tray (C) was set up in a similar way as tray A and tray B. The tips of the shoots were covered with aluminium foil. The diagram below shows the appearance of the shoots at the start and after being exposed to light from one direction only.

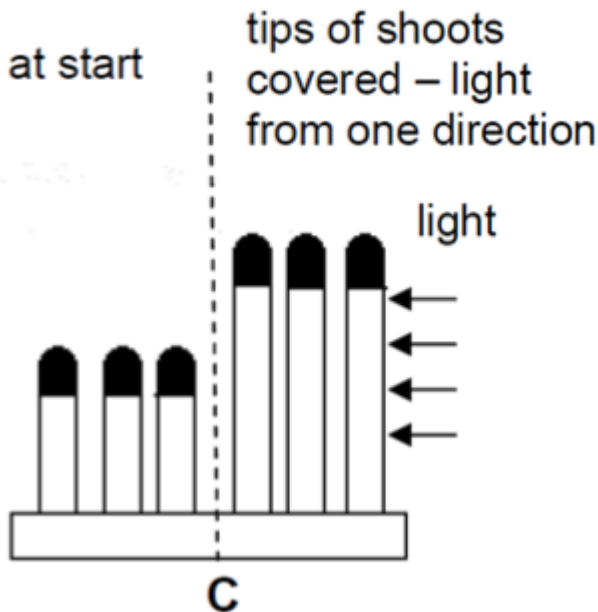

1.4 What conclusion can you draw from the results obtained in tray C?

1.5 Name ONE use in agriculture of the following:

- (a) Auxins
- (b) Gibberellins

**Question 2** (*Adapted from Nov 2011, P2, Question 4.2*)

Sipho did an investigation in his laboratory to look at the effect of different concentrations of auxin on cell elongation in coleoptiles (young stems). He used the following procedure:

- Fifteen (15) coleoptiles from one species of oat plants were used.
- All the coleoptiles used were of the same length.
- The tips of twelve (12) coleoptiles were cut.
- These coleoptiles were put into four groups (A, B, C and D). Each group of three coleoptiles was injected with a different concentration of auxin as shown in the table below.
- The last group (E) was used as a control in which the coleoptiles were not injected with auxin and tips were not cut.

After four days the length of coleoptiles in each group were measured and an average was calculated.



GROUP	TREATMENT		
	TIP (PRESENT/ ABSENT)	CONCENTRATION OF AUXIN INJECTED (ARBITRARY UNITS)	AVERAGE LENGTH OF COLEOPTILE (mm)
A	Absent	1	36
B	Absent	2	60
C	Absent	3	32
D	Absent	4	24
E	Present	0	30

- 2.1 Formulate a hypothesis for the investigation above.
- 2.2 Suggest why Sipho cut off the tips of each coleoptile before he injected them with auxin.
- 2.3 Apart from the factors that were kept constant, state ONE other factor that Sipho should have kept constant in all the groups.
- 2.4 What conclusion can be drawn from the results, about the effect of auxin concentration on cell elongation in the coleoptiles?

**Question 3** (Adapted from Feb/Mar 2012, P2, Question 4.1)

A group of Grade 12 learners carried out an investigation to determine the effect of gibberellin on the germination of seeds.

The following procedure was followed:

- A sample of hazelnut seeds was divided into two groups, A and B.
- A gibberellin solution was added to the seeds in group A.
- Water was added to the seeds in group B.
- Both groups of seeds were allowed to germinate for 16 days.
- The percentage (%) of seeds germinating in the two groups was recorded.

The results of the investigation are shown in the graph below.

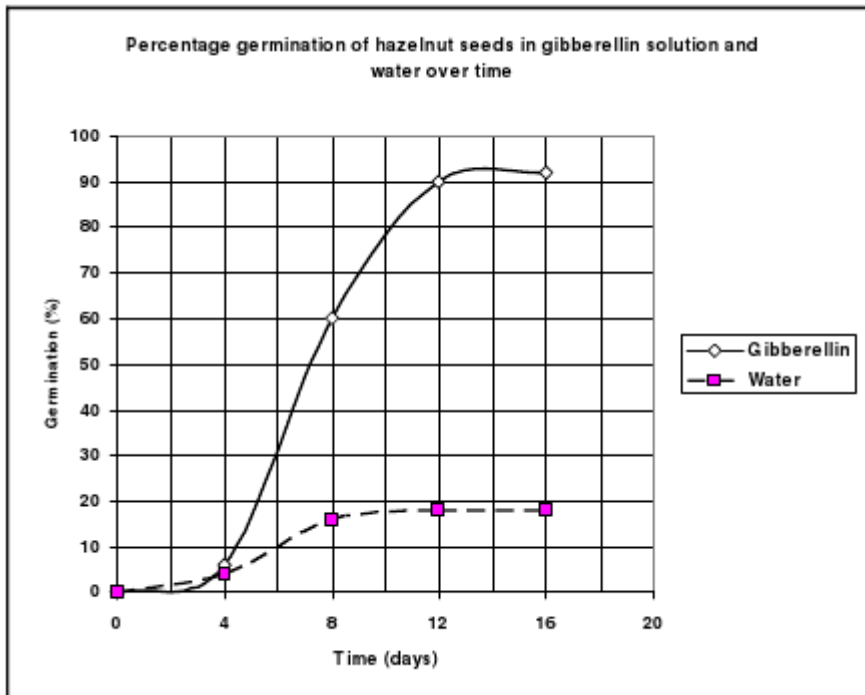

- 3.1 Formulate a possible hypothesis for this investigation.
- 3.2 Using the information from the graph, determine the percentage germination of hazelnut seeds on the 10th day with the gibberellins treatment.
- 3.3 Explain the purpose of group B.
- 3.4 State TWO ways in which the validity of this investigation could have been improved.
- 3.5 Give ONE possible reason why seeds of desert plants germinate only after heavy rains.



## ANIMAL RESPONSES TO THE ENVIRONMENT

**Question 1** (Adapted from Nov 2011, P2, & Exemplar 2011, P2, Question 1.1)

QUESTION 1.1 and QUESTION 1.2 are based on the diagram of a reflex arc shown below.

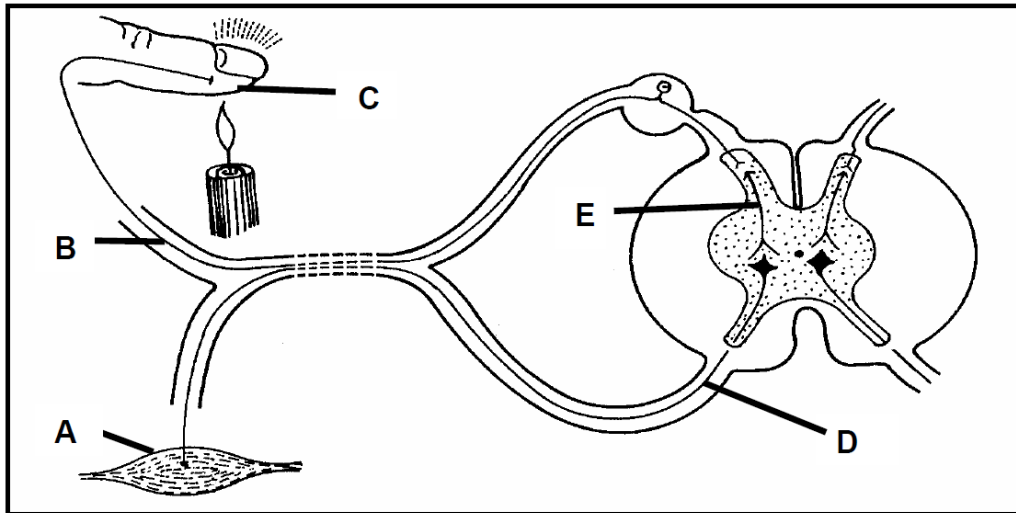

- 1.1 Part B indicates the ...
- A dendrite of the motor neuron.
  - B axon of the motor neuron.
  - C dendrite of the sensory neuron.
  - D axon of the sensory neuron.
- 1.2 The correct sequence in which impulses move from the receptor to the effector in the reflex arc above, is ...
- A A → B → C → D → E
  - B C → A → B → E → D
  - C C → B → E → D → A
  - D A → D → E → B → C
- 1.3 Which of the following is an exocrine gland?
- A Thyroid
  - B Pancreas
  - C Adrenal
  - D Pituitary
- 1.4 The ability of the lens to change its curvature is known as ...
- A astigmatism.
  - B binocular vision.
  - C accommodation.
  - D pupillary mechanism.



[www.learnxtra.co.za](http://www.learnxtra.co.za)

- 1.5 Diabetes is caused by an ...
- A oversecretion of adrenalin.
  - B undersecretion of insulin.
  - C oversecretion of aldosterone.
  - D undersecretion of glucagon.

**Question 2** (Adapted from Nov 2011, P2, Question 2.1)

Study the diagram below showing a portion of the human ear and answer the questions that follow.

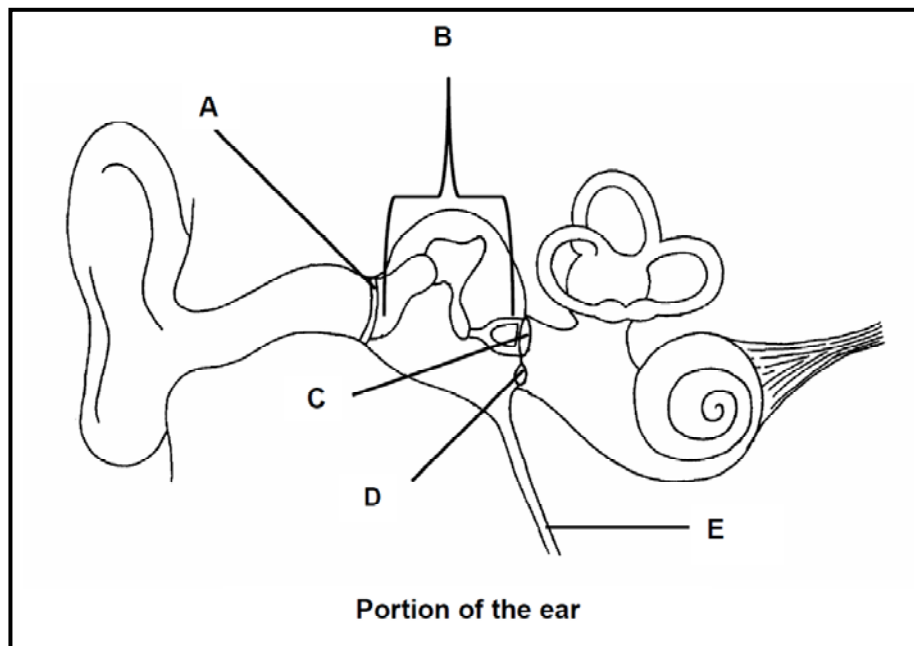

- 2.1 Provide labels for parts A, C and D, respectively (3)
- 2.2 State ONE function for parts B and D, respectively. (2)
- 2.3 How are parts A and C together suited for the amplification of sound? (2)
- 2.4 Explain what would happen if part E is blocked with mucus. (2)



**Question 3.1** (Adapted from Feb/Mar 2012, P2, Question 2.1)

Study the diagram below showing a longitudinal section through an eye.

**A longitudinal section through a human eye**

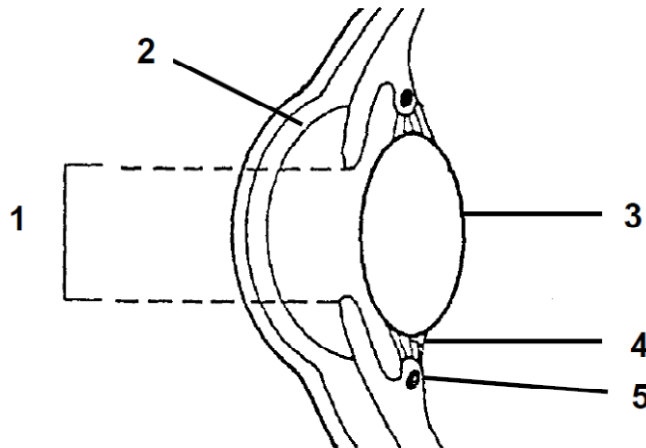

- 3.1.1 Label parts 2, 3, 4 and 5 respectively. (4)
- 3.1.2 Name and describe the process that causes part 1 to dilate. (6)
- 3.1.3 State how the following defects can be treated to improve vision: (4)
- Longsightedness
  - Astigmatism
  - Cataract
  - Shortsightedness

**Question 3.2** (Adapted from Nov 2011, P2, Question 2.2)

Jabu took part in an experiment on the eye's response to light. A lamp was placed at seven positions from Jabu's face. The diameter of Jabu's pupil was measured at each position.

The results are shown in the table below.

POSITION OF THE LAMP	DIAMETER OF THE PUPIL (mm)
1	1,2
2	1,8
3	2,4
4	3,0
5	3,6
6	4,2
7	4,8

- 3.2.1 (a) At which position was the lamp furthest from the eye? (1)
- (b) Explain your answer to QUESTION 3.2.1(a). (2)
- 3.2.2 When the lamp was moved from position 1 to position 2, describe the mechanism that caused the change in the diameter of the pupil. (4)



**Question 4.1** (Adapted from Feb/Mar 2012, P2, Question 2.2)

Study the diagram below showing a reflex arc.

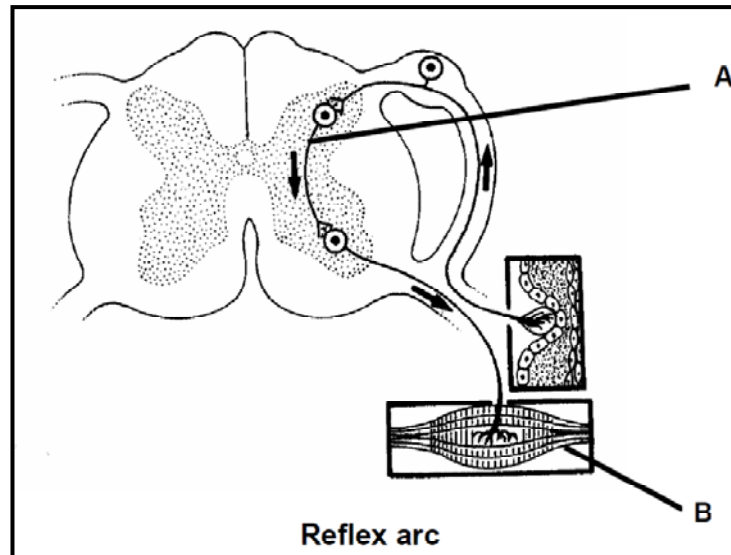

- 4.1.1 Identify the neuron labelled A. (1)
- 4.1.2 Name the type of neuron that is connected to structure B. (1)
- 4.1.3 Explain the effect on the body if the neuron mentioned in QUESTION 4.1.2, is damaged. (3)
- 4.1.4 Explain the significance of reflex actions in humans. (2)

**Question 4.2** (Adapted from Nov 2011, P2, Question 1.4)

Study the diagram below and answer the questions that follow.

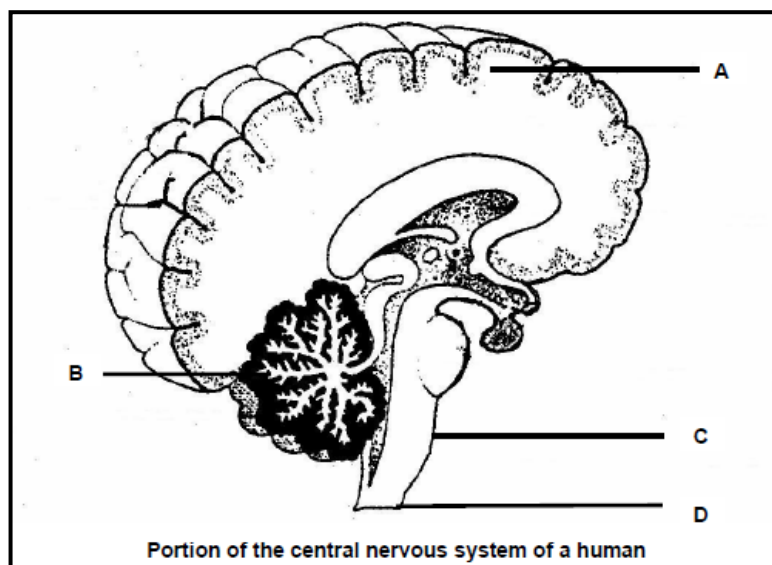

- 4.2.1 Write down only the letter (A–D) of the part which:





- (a) Controls heartbeat (1)
- (b) Contains the centres that control balance, muscle tone and equilibrium (1)
- (c) Has centres that interpret what you see (1)
- (d) Coordinates voluntary muscle movements (1)
- (e) Has grey matter on the inside and white matter on the outside. (1)

**Question 4.3** (Adapted from Feb/Mar 2012, P2, Question 4.2)

Study the diagram below and answer the questions that follow.

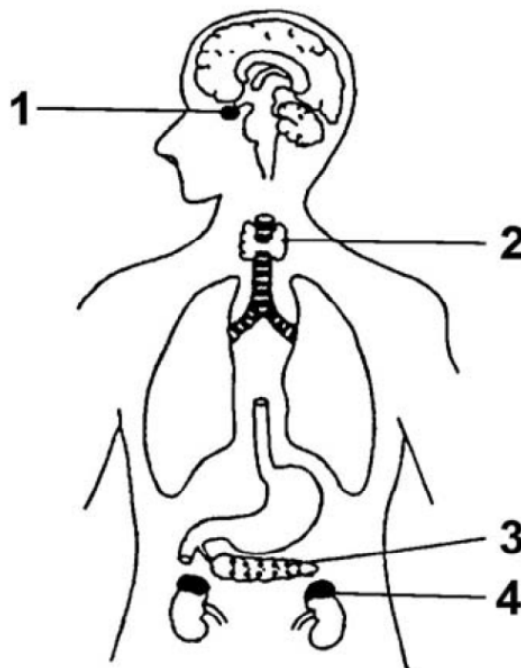

- 4.3.1 Label the parts numbered 1 and 4. (2)
- 4.3.2 Write down only the NUMBER of the gland that:
  - (a) Produces the hormone glucagon
  - (b) Produces a hormone that controls the growth of long bones
  - (c) Produces an iodine containing hormone
  - (d) Produces a hormone that is involved in the reabsorption of some salts by the kidneys (4)
- 4.3.3 State TWO similarities between hormones and nerves with regard to their functions. (2)
- 4.3.4 State ONE functional difference between hormones and motor nerves. (2)



## REPRODUCTION

### CHECK LIST

Make sure you can:

- Compare asexual and sexual reproduction
- Describe and draw diagrams to show the life cycles flowering plants and the moss to show the alternation of generation
- Describe the life cycles of insects
- Draw labelled diagrams of the flower to show the structure and function of each part in the process of sexual reproduction
- Discuss the adaptations of South African plants for reproduction
- Describe the diversity of reproductive strategies in animals

### STUDY NOTES

#### TERMINOLOGY & DEFINITIONS

- **Gametophyte generation:** this generation is **haploid** and produces gametes by **mitosis**.
- **Sporophyte generation:** this generation is **diploid** and produces haploid spores by **meiosis**.
- **Metamorphosis:** a process of abrupt transition from one developmental stage to another. Metamorphosis can be complete (egg, larva, pupa and adult) or incomplete (egg, nymph and adult).
- **Viviparous:** embryo carried in the uterus and female gives birth to live young.
- **Oviparous:** egg with shells are laid outside the female's body and embryo develops inside the egg until ready to hatch.
- **Ovoviviparous:** shell-less fertilized eggs remain in the female's oviduct until embryo is developed, then female gives birth to live young.
- **Precocial:** young are mature and able to fend for themselves directly after hatching.
- **Altricial:** young are born helpless and require protective parental care.
- **Alternation of generations:** a life cycle alternating between the sporophyte generation (diploid) and the gametophyte generation (haploid)
- **Asexual reproduction:** reproduction without the fusion of sex cells e.g. budding, binary fission
- **Budding:** a form of asexual reproduction where new cells develop into an outgrowth on the parent plant
- **Dioecious:** means unisexual, where the male and female reproductive organs are borne on different plants
- **Cross-pollination:** pollen is transferred from one flower to another flower to enable fertilisation. The stamens and pistils ripen at different times to ensure that self-pollination does not take place
- **Monoecious:** applicable to flowering plants that have separate male and female flowers carried on the same plant
- **Plumule:** part of the plant embryo that develops into the shoot and later young leaves
- **Pollen grain:** microspores of flowering plants that contain the male gametes
- **Pollination:** transfer of pollen from the anther to a ripe and receptive stigma
- **Self-pollination:** when the pollen of a flower falls on the stigma of the same flower



- **Cross-pollination:** is the transfer of pollen from the anther of one plant to the receptive stigma of a flower on another plant of the same species.
- **Stamen:** male reproductive organ of a flower that carries the anther at the tip
- **Stigma:** end part of the ovary which receives pollen
- **Unisexual:** the stamens and pistils are located on separate flowers

**Summary of Sexual and Asexual Reproduction:**

Reproduction type	Sexual reproduction	Asexual reproduction
<b>Explanation</b>	<ul style="list-style-type: none"> <li>• Two parents</li> <li>• Requires the formation of <b>haploid male and female gametes</b> by the process of meiosis</li> <li>• The process of <b>fertilisation</b> must take place</li> <li>• <b>A diploid zygote</b> results and develops into an embryo that contains genes from both the male and the female</li> <li>• <b>Less</b> offspring result (babies, fruits and seeds)</li> </ul>	<ul style="list-style-type: none"> <li>• One parent</li> <li>• Requires <b>vegetative structures</b> that grow from the parent plant by mitosis – no gametes are produced</li> <li>• No fertilisation is required – the offspring are as a result of <b>mitosis</b></li> <li>• The resulting offspring are <b>diploid and identical</b> to the parent</li> <li>• <b>Rapid</b> production of <b>large numbers</b> of offspring</li> </ul>
<b>Advantage</b>	<ul style="list-style-type: none"> <li>• The recombination of the chromosomes during <b>meiosis</b> and the random fusion of gametes during fertilisation results in offspring that show <b>genetic variation</b></li> </ul>	<ul style="list-style-type: none"> <li>• Asexual reproduction is ideal for producing large numbers of identical offspring with <b>desirable genetic characteristics</b>, from one selected parent</li> </ul>
<b>Disadvantage</b>	<ul style="list-style-type: none"> <li>• Male and female gametes may be prevented from fusing – so no offspring will be produced</li> <li>• Genetic mutations may result in undesired characteristics in the offspring</li> </ul>	<ul style="list-style-type: none"> <li>• Offspring are identical to the parent and show <b>no genetic variation</b></li> </ul>



### Comparison of Alternation of Generations in plants

	Gametophyte generation	Sporophyte generation
<b>Moss</b>	<b>Dominant phase.</b> Water is essential for fertilisation to occur.	<b>Partly parasitic</b> and develops from the gametophyte structure. Sporophyte structure undergoes meiosis to produce spores.
<b>Flowering plants</b>	Gametophyte structures for male and female <b>are part</b> of the sporophyte. Gametes are produced. Fertilisation results in a <b>diploid zygote</b> that will develop into an embryo.	<b>Dominant phase.</b> Various adaptations exist to ensure pollination. <b>Fruit and seeds</b> are produced which grow into a new sporophyte structure.

#### Question 1 (Nov 2011 P2 Q1.5)

Study the diagrams of the structures of two flowers below. The magnification of each flower is indicated in brackets.

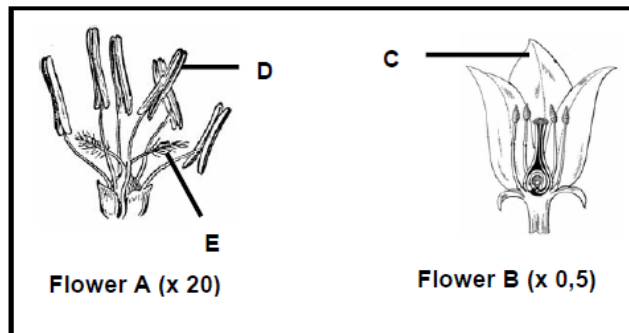

- 1.1 Provide labels for C, D and E. (3)
  - 1.2 Which flower (**A** or **B**) is probably pollinated by insects? (1)
  - 1.3 Which flower's (A or B) actual size is greater? (1)
- [5]**



**Question 2**

The diagram on the following page represents the life cycle of a butterfly.

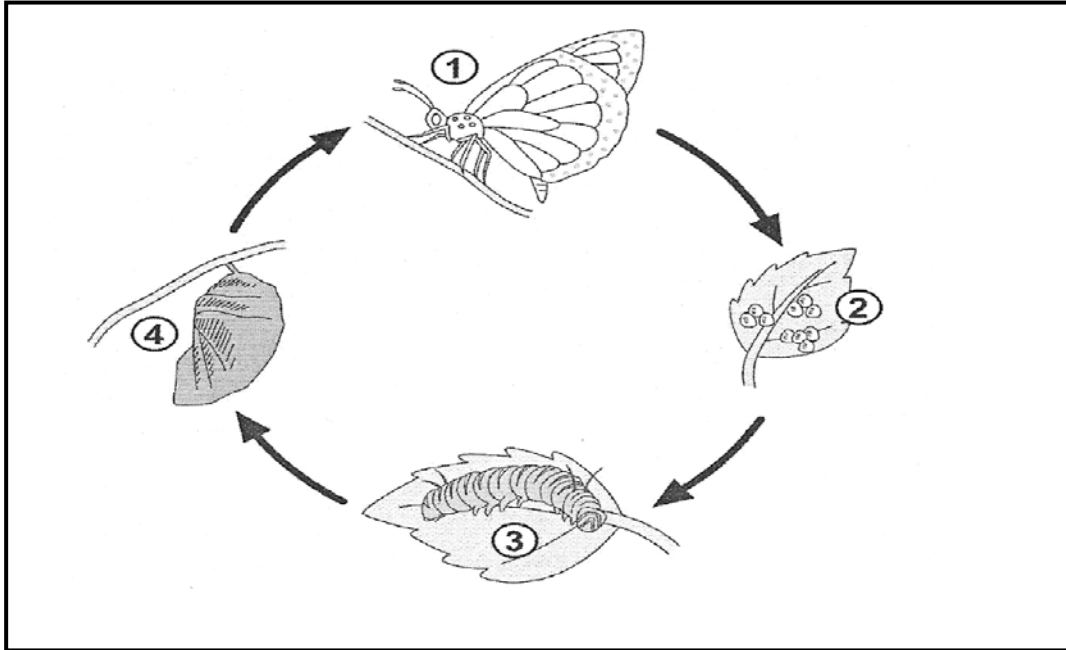

- 2.1. Name the type of metamorphosis shown in this diagram. Explain your answer. (4)
- 2.2. Label the stages numbered 1 to 4. (4)
- 2.3. Explain the major difference between complete and incomplete metamorphosis. (4)
- [12]**



**Question 3:** (Adapted from Exemplar 2011 Paper 2)

Study the diagram of the life cycle of a plant in which the gametophyte generation is dominant, on the following page.

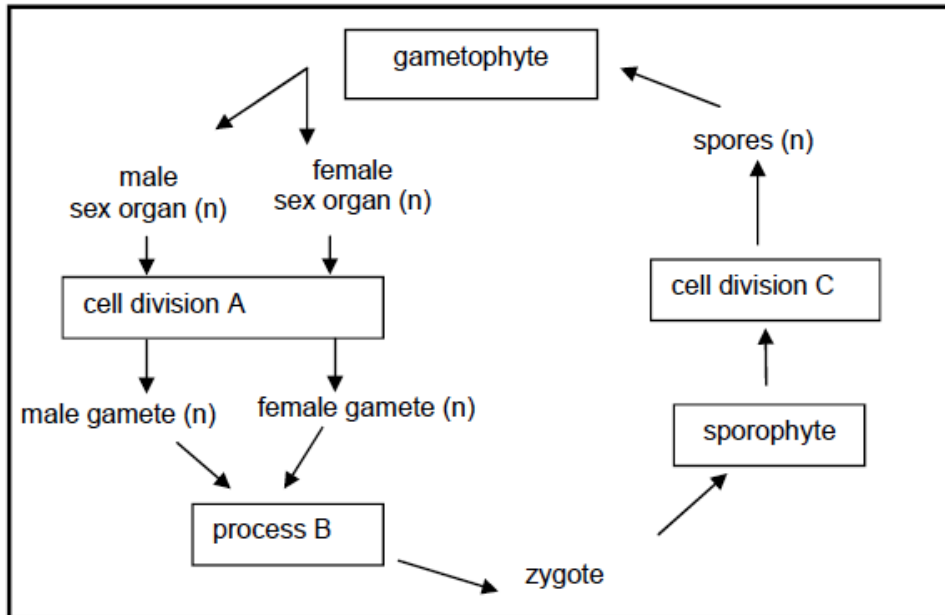

- 3.1. Is the life cycle represented that of moss or a flowering plant? (1)
  - 3.2. Name the following:
    - (a) Cell division A (1)
    - (b) Process B (1)
    - (c) Cell division C (1)
  - 3.3. Is the gametophyte haploid or diploid? (1)
  - 3.4. Are seeds produced during the life cycle of this plant? (1)
- [6]**

**Question 4**

The following diagram represents a section through an amniotic egg:

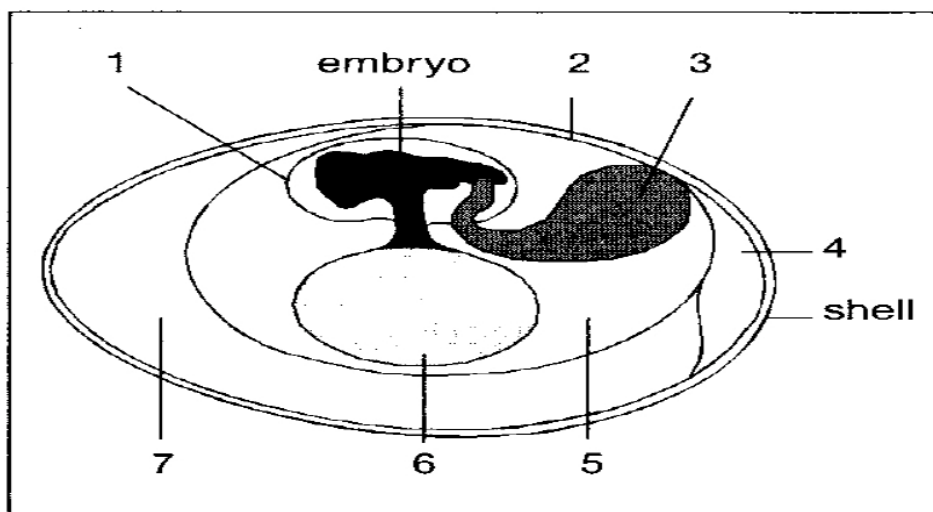



- 4.1. Identify the membrane numbered 1. (1)
- 4.2. What fills the space between the developing embryo and the membrane mentioned in QUESTION 3.1, and what is its function? (2)
- 4.3. Which number represents the allantois? State one function of this structure. (2)
- 4.4. Identify the membrane numbered 2, and state its function. (2)
- 4.5. Did internal or external fertilisation occur to produce the structure in the diagram? (1)
- 4.6. Explain the difference between viviparous and oviparous embryo development. (8)
- 4.7. Briefly explain the meaning of the terms: (3)
- a) precocial young (3)
- b) altricial young (3)
- [22]**

**Question 5**

- 5.1. Discuss the importance of seeds as a food source. (4)
- 5.2. Name four types of stems that are organs of asexual reproduction and include an example of each. (8)
- 5.3. Tabulate the advantages and disadvantages between sexual and asexual reproduction. (10)
- 5.4. Briefly describe the difference between self-pollination and cross pollination. (3)





## HUMAN REPRODUCTION

### CHECK LIST

Make sure you can:

- Draw a diagram to show the role of meiosis, mitosis and fertilisation in the human life cycle
- Describe and draw labelled diagrams of the structure of the male and female reproductive systems of humans
- Explain the processes involved in Gametogenesis
- Describe the processes in Ovulation and menstruation
- Describe the stages involved in the development of a human from conception to birth
- Discuss different methods of contraception
- Explain the causes, transmission, symptoms, treatment and prevention of sexually transmitted diseases e.g syphilis and gonorrhoea

### STUDY NOTES

#### TERMINOLOGY & DEFINITIONS

- **Corpus luteum:** structure that results when the Graafian follicle releases the egg cell during ovulation. The corpus luteum also secretes progesterone if the egg is fertilised
- **Follicle stimulating hormone: (FSH)** produced by the anterior lobe of the pituitary gland and causes the maturing of the follicle surrounding the oocyte and stimulates the supply of nutrients
- **Gametogenesis:** the formation of gametes
- **Gonadotrophic hormones:** hormones secreted by the pituitary gland to control reproductive cycles and processes in males and females
- **Luteinising hormone (LH):** a hormone produced by the anterior lobe of the pituitary gland that stimulates the release of oestrogen into the bloodstream which causes ovulation
- **Menstrual cycle:** this cycle begins with menstruation and continues for 28 days. It is controlled by hormones to co-ordinate the release of the mature egg cell with the readiness of the uterus for implantation, if fertilisation takes place
- **Menstruation:** when there is no fertilisation, the lining of the uterus is shed to prepare for the next cycle. This results in a flow of blood that lasts for approximately 5 days.
- **Oestrogen:** a hormone secreted by the ovaries, causing ovulation
- **Oogenesis:** the process to produce haploid egg cells in the follicles of the ovary
- **Progesterone:** a hormone secreted by the corpus luteum when the egg cell is fertilised to ensure pregnancy
- **Copulation:** the insertion of the male reproductive organ into the female reproductive organ to transfer sperm to the egg cell
- **Fertilisation:** fusion of two haploid gametes (sperm cell and egg cell) to form a diploid zygote



- **Internal fertilisation:** fertilisation that occurs inside the body of the female, inside the Fallopian tube
- **Pregnancy:** it is the development of the embryo inside the uterus. It can also be called gestation.
- **Vasodilation:** is the increase of blood volume causing the penis to become erect. The erect penile tissue closes the valve of the urethra to prevent the possibility of urination during ejaculation of the sperm cells.
- **Amnion:** fluid-filled sac where the embryo develops in the uterus
- **Amniotic fluid:** fluid surrounding the foetus in the amnion
- **Placenta:** a structure that grows from the wall of the uterus to prevent direct contact of the mother's blood with that of the foetus.
- **Umbilical cord:** links the placenta to the developing foetus
- **Afterbirth:** the mass of placenta and membranes that are expelled from the uterus after the birth of a baby
- **In vitro fertilisation (IVF):** This is when one or more eggs is fertilised outside the woman's body and transferred into the uterus for development and growth.
- **Dizygotic or fraternal twins:** (di = two) when more than one egg is released during ovulation and fertilised. The developing foetuses share the same uterus, but each foetus has a separate placenta and their own amnion. The twins are not identical;
- **Monozygotic or maternal twins:** (mono = one) when one egg is fertilised and the egg zygote or blastocyst separates into two structures, identical twins will result. The twins have the same sex and be identical in genetic inheritance and appearance. The placenta will be fused with a common embryonic membrane.
- **Conjoined twins:** Sometimes the splitting of the embryo into two (monozygotic twins) is not complete, resulting in the twins remaining joined at areas and they may even share internal organs. The conjoined twins are called Siamese twins.
- **Contraception:** (also called birth control) various methods are used to prevent conception and the development of the embryo.
- **STDs:** sexually transmitted diseases
- **Abstinence:** no sexual intercourse takes place
- **Monogamy:** when people only have one sexual partner
- **Opportunistic diseases:** diseases that attack the body when the immune system is suppressed
- **Sexual promiscuity:** when people have multiple sexual partners



## HORMONAL CONTROL OF OOGENESIS:

- Hormones control the 28 day **menstruation cycle**. Usually only one egg is released per cycle. Should both ovaries release an egg cell and both are fertilised, the result is paternal twins (unidentical). The menstruation cycle affects the ovaries and the uterus.
- **Gonadotrophin releasing hormone** (GnRH) stimulates the anterior pituitary gland to release follicle stimulating hormone (FSH) into the blood.
- **FSH** is transported to the ovaries (target organ) where it stimulates the development of the follicle.
- Granulosa cells in the developing follicle produce **oestrogen**. Oestrogen has two target organs, namely the uterus and the anterior pituitary gland.
  - Oestrogen causes the development of the endometrium in the uterus to prepare it for pregnancy.
  - Oestrogen inhibits the secretion of FSH by the anterior pituitary gland so that no further follicles are produced during the pregnancy. High oestrogen levels will trigger the secretion of luteinising hormone (LH).
- **LH** is released into the blood and is transported to the ovary, causing ovulation. **LH** stimulates the Graafian follicle to develop into the corpus luteum.
- The corpus luteum secretes **oestrogen and progesterone**.
  - Progesterone ensures that the thickening of the **endometrium** is maintained and **glandular activity** is stimulated.
  - Progesterone **inhibits** the anterior pituitary gland from releasing LH. The release of progesterone causes the slight **rise in temperature** just after a female has ovulated.
- If fertilisation does not take place, the corpus luteum will **degenerate** causing a decrease in the levels of oestrogen and progesterone. The endometrium breaks down and tears away from the walls of the uterus, causing the bleeding associated with **menstruation**. This lasts for about five days.

## FERTILISATION

Meiosis takes place in the ovary and testes to produce **haploid gametes**. The sperm cell must enter the female body and make its way to the egg cell, so that **fertilisation** can take place to form a **diploid zygote**. Remember that humans require **internal fertilisation** for the reproductive process to take place. The zygote will be a combination of the **hereditary characteristics** of both the male and the female. The zygote will develop into an embryo and then a foetus by mitosis. The foetus will grow inside the uterus of the female's body for 40 weeks where it is well protected. This is called gestation or pregnancy. At full term, the female will give birth to **ensure survival and continuation** of the species.

[**NOTE:** Please learn this diagram well as it is often asked. Remember that the egg cell and sperm cells are all haploid. Once fertilisation takes place, the zygote is diploid.]

**Development of the placenta and amnion:** The placenta is a structure that **forms a link** between the mother and the developing foetus. It ensures that there is **no direct transfer** of the mother's blood to the foetus. The placenta develops about 12 weeks



after conception and allows for the safe exchange of a number of substances between the mother to the foetus through the **umbilical cord**:

- **Nutrients, oxygen, hormones and antibodies** from mother to foetus
- **Carbon dioxide and wastes** from the foetus to the mother, for excretion by the mother
- **Harmful substances** like nicotine from cigarette smoking, alcohol, drugs and viruses like rubella (German measles), hepatitis B and HIV can also move through the placenta.

The **amnion** is a membranous bag-like structure that develops around the embryo and is filled with **amniotic fluid**. It has the following functions:

- to **protect the embryo** by acting as a shock absorber
- regulating the embryo's **body temperature**.

## THE BIRTH PROCESS

It is called **parturition** because the baby 'parts' with the mother's body. A hormone called **oxytocin** is secreted by the posterior lobe of the pituitary gland of the mother and causes uterine contractions and the **dilation of the cervix**. Labour begins with contractions, causing the **amnion to burst** ('water breaks'). The contractions force the baby down through the pelvic bones and the birth canal. Once the baby is born, the umbilical cord is clamped off and cut (umbilical cord connects the baby to the placenta). The mother has more contractions to expel the placenta which is commonly called the afterbirth. After birth, the mother produces a hormone called **prolactin** to stimulate milk production. For the first few days **colostrum is produced**. It is a fluid that contains antibodies, proteins and assists to clear out the baby's digestive tract. By the fourth day, normal milk is produced by the mammary glands. This production of milk is called **lactation**. Breast milk contains antibodies and all the nutrients required by the developing baby. HIV positive mothers may not breastfeed their babies as the virus is present in breast milk.

## ABORTION DEBATE

Abortion is the premature and deliberate termination of a pregnancy. The abortion procedure is performed by qualified staff up to 12 weeks of pregnancy. It may be legally performed up to 24 weeks in cases where genetic deformities of the foetus are suspected or the mother is in physical danger. The mother should be **counselled** before and after the procedure. Whether abortion is acceptable to you or not will depend on your belief systems. The following are some of the 'pros' and 'cons' for the abortion debate.

### Possible Anti-abortion points:

- The unborn foetus is a living being from conception (fertilisation has taken place)
- The foetus has a brain, heart and other organs early in its development (by 10 weeks) and can, therefore, feel pain
- Abortion is legalised killing/murder since you are taking away a life
- Many religions and cultures do not condone abortion – this goes against their morality/ethics that could lead to conflict in the family
- The mother-to-be also experiences deep emotional trauma and depression long after she has aborted her child – even if she has made the choice to abort



- Why should abortion be condoned when there are many contraceptive methods available
- Couples that have sexual relations must be responsible/ if a baby is conceived, it should be accepted and loved, no matter what

**Possible Pro-abortion points:**

- Abortion is legal in South Africa – it is enshrined in our constitution – women have a choice .
- The foetus does not have the status of a child in South Africa.
- Abortion is better than bringing an unwanted child into the world and abandoning it.
- The abandoned child could possibly have anti-social behaviour and become a problem.
- Sometimes women do not have a choice about the use of contraceptives / it is male controlled / she falls pregnant not out of choice / she is raped – abortion is the only option in this case.

[**NOTE:** Be sure to learn the table on birth control because you may be asked to compare various types of birth control. Abortion is a very topical debate. Make sure that if you are asked to give your view, that you only discuss being for **OR** against abortion. Never discuss both views unless you are asked to debate the topic.]

**STDs**

Sexually transmitted diseases (STDs) are diseases that are transferred by **sexual contact**. They are very common and widely spread. Research has found that the incidence of STDs has doubled since 2002. In the past, communities blamed prostitution for the spread of STDs but the latest findings point to the acceptance of sexual promiscuity and the apparent moral decline of societies.

STDs are caused by **viruses and bacteria** and are transferred by sexual intercourse. In some cases, the symptoms are not immediate, meaning a person is a carrier without being aware of it. STDs can be prevented by **abstinence**, the use of **condoms** and the improvement of moral standards.



**Question 1** (Nov 2011 P2 Q2.3)

Study the graph alongside of a menstrual cycle and the influence of the different hormones on it.

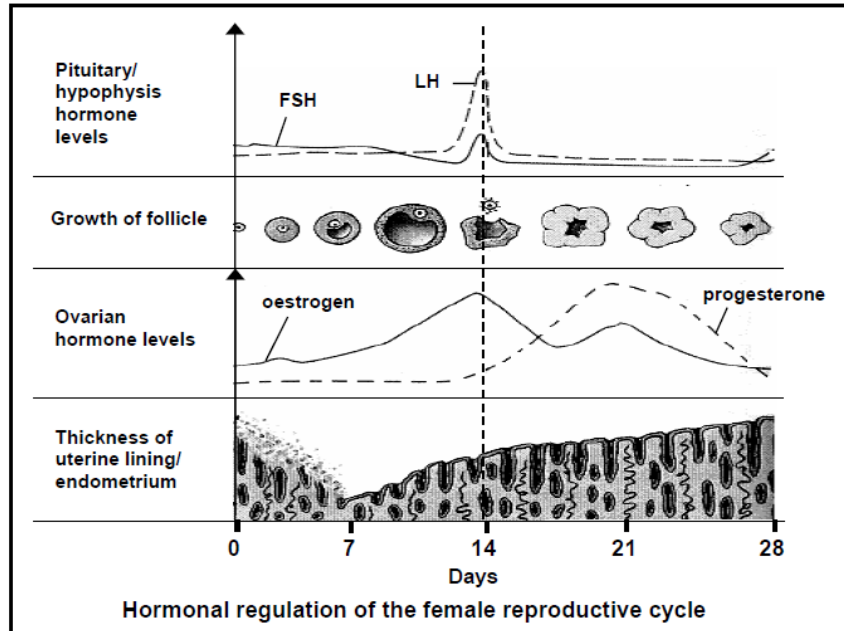

- On which day does ovulation take place? (1)
- 1.2 Between which days does menstruation take place? (1)
- 1.3 State ONE function of FSH during the menstrual cycle. (1)
- 1.4 Describe the functional relationship between progesterone and FSH. (2)
- 1.5 Account for the change in the thickness of the endometrial lining between day 14 and day 21. (2)
- 1.6 Did fertilisation take place within the 28-day cycle illustrated in the graph? (1)
- 1.7 Give TWO reasons for your answer to QUESTION 1.6. (2)

**Question 2**

The diagram below represents a part of the human female reproductive system after copulation. Study the diagram and answer the questions that follow.



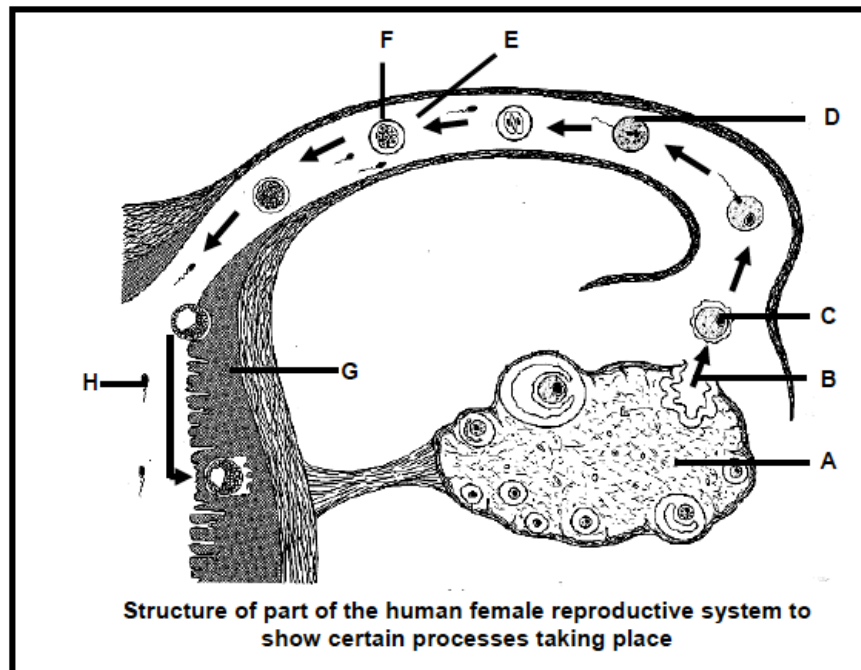

- 2.1. Give labels for parts A, E and G respectively. (3)
  - 2.2. Name the process that takes place at B. (1)
  - 2.3. When, during the menstrual cycle, does the process mentioned in QUESTION 2.2. take place? (1)
  - 2.4. Describe the process represented by D. (3)
  - 2.5. Write down the number of chromosomes that would be present in the nucleus of the following:
    - a) Cell C (1)
    - b) One cell of F (1)
    - c) Cell H (1)
- [11]**





**Question 3:**

Study the diagram of the developing foetus below.

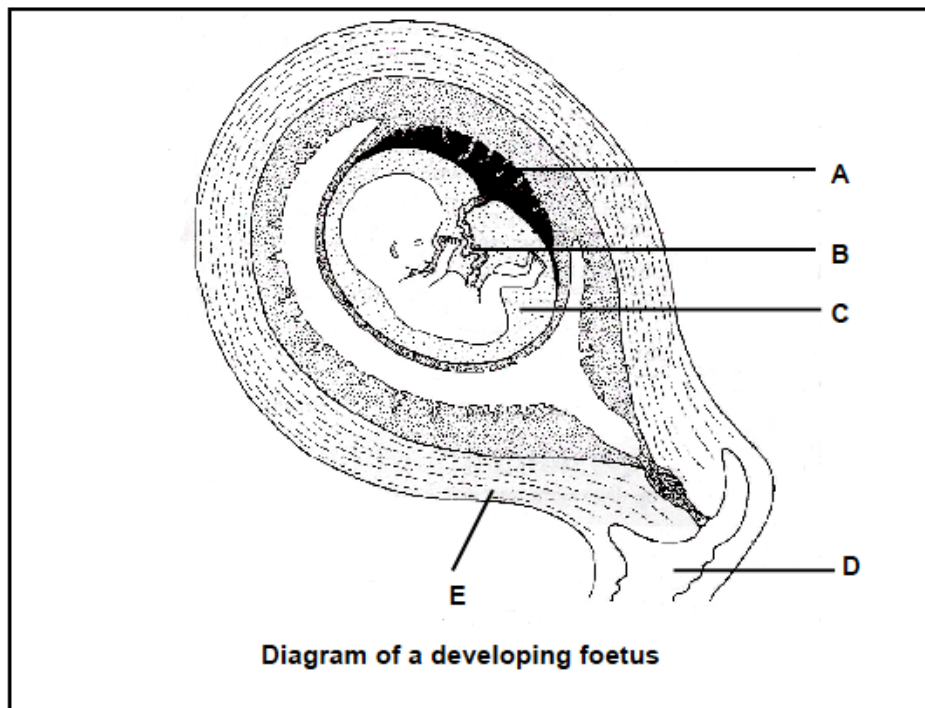

- |      |   |            |
|------|---|------------|
| 3.1. | Label structures A, B and D.  | (3)        |
| 3.2. | Give TWO functions of the fluid found in C.   | (2)        |
| 3.3. | Name the process by which some of the fluid from C is withdrawn by doctors to test for abnormalities in the foetus. | (1)        |
| 3.4. | Describe the function of E during the birth process.  | (2)        |
|      |   | <b>[8]</b> |



**Question 4:**

The table shows the results of a survey of the different types of contraceptives used in a particular community:

Method	Number	Percentage
Pill	4321	86,4
IUD	157	3,1
Condom	320	6,4
Injections	112	2,2
Other	90	1,8

- 4.1 State a hypothesis for this survey. (2)
- 4.2 How would you get the information recorded in the table shown here? (1)
- 4.3 Which of the method/s represented in the table can be classified as a chemical method? (2)
- 4.4 Which method/s represented in the table will prevent the transfer of STDs?(2)
- 4.5 Draw a pie graph showing the percentage distribution of the different contraceptive methods. Show all your calculations. (14)
- [21]**

**Question 5**

Match column A with the statements in column B:

Column A	Column B
1. uterus	A. the external opening of the vagina
2. Fallopian tube	B. releases the egg cell during ovulation
3. testis	C. produces the hormone testosterone
4. cervix	D. development of the foetus takes place here
5. ovary	E. develops into the Graafian follicle
6. corpus luteum	F. organ enclosed by a scrotum
7. primary follicle	G. secretes progesterone
8. cells of Sertoli	H. provides nutrition of the sperm cells
9. epididymus	I. deposits sperm cells into the female
10. penis	J. transports egg cells from the ovary to the uterus
	K. region in the female that separates the vagina and the uterus
	L. produced by the Cowper's gland
	M. region where the sperm cells mature before release

**[10]**



## POPULATION ECOLOGY

**Question 1** (Adapted from Nov 2011, P2, Question 1.1.7 - 1.1.10)

QUESTION 1.1 and QUESTION 1.2 are based on the graph below. Study the graph and answer the questions that follow.

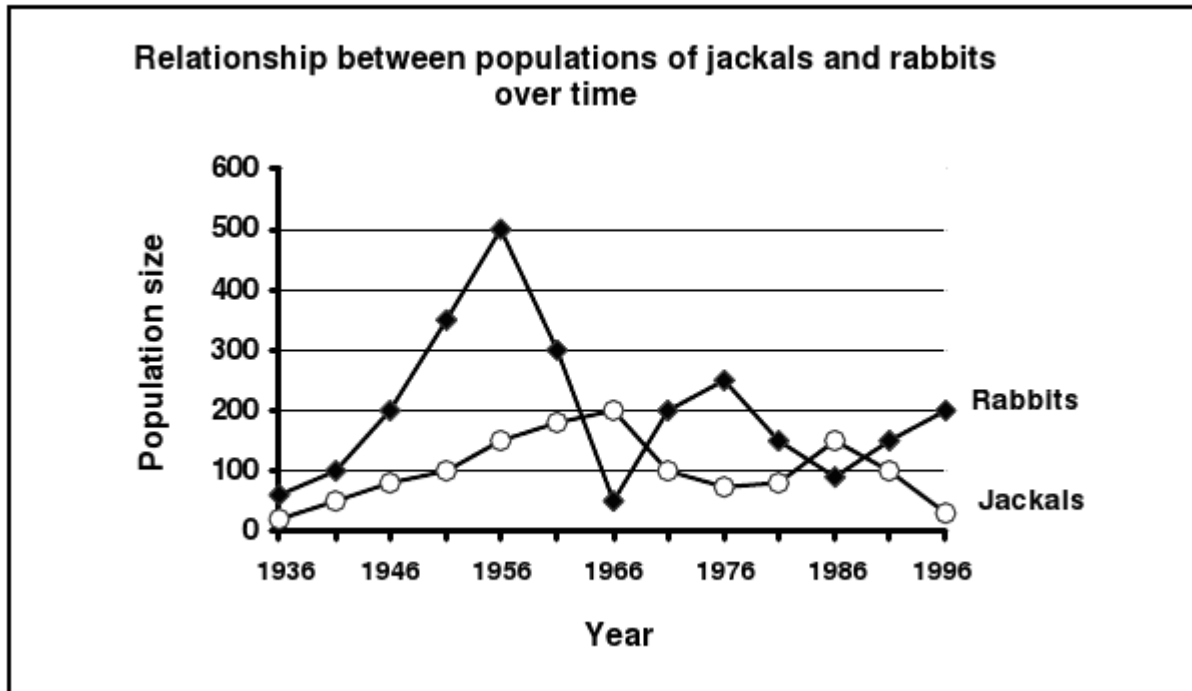

1.1 Which interaction in a community is illustrated by the graph above?

- A Parasitism
- B Predation
- C Commensalism
- D Division of labour in a colony

1.2 What effect does a decrease in the number of jackals have on the rabbit population?

- A Rabbit population decreases
- B Rabbit population is eliminated from the habitat after a long period of time
- C Rabbit population increases
- D Both the rabbit population and the jackal population are eliminated from the habitat



1.3 Study the age-gender pyramid shown below for a developing country.

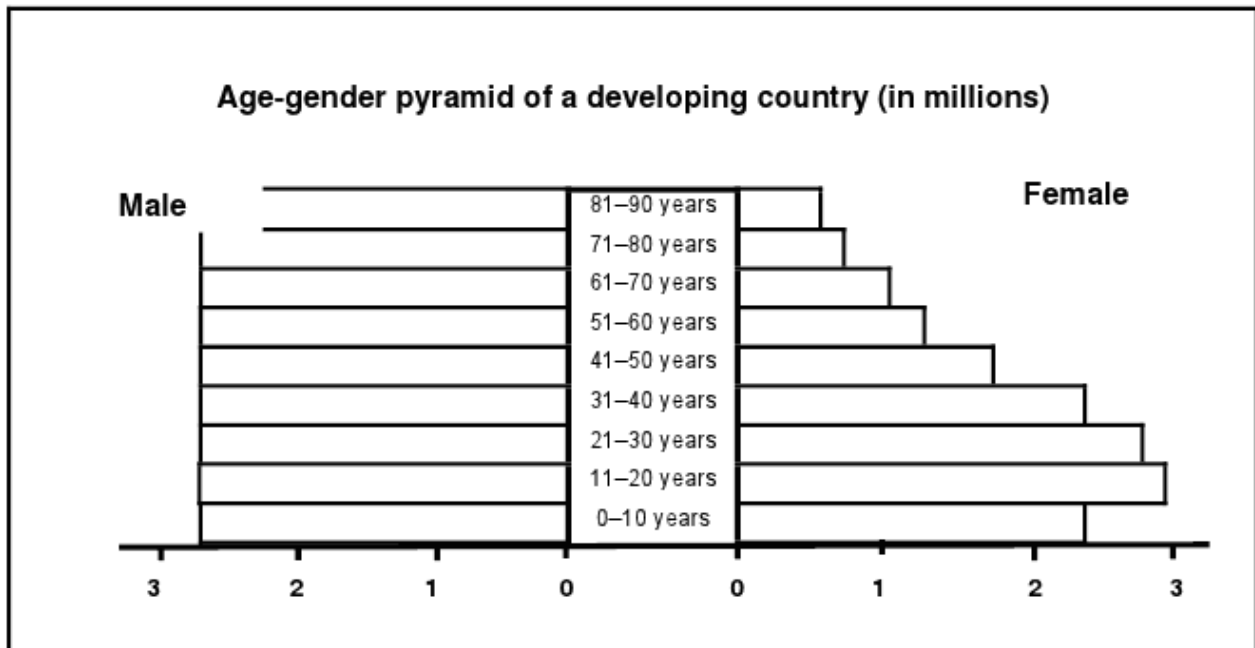

Which ONE of the following can be CORRECTLY deduced from the age-gender pyramid above?

- A An even spread of number at each age group
- B Population has a high number of people at reproductive age compared to pre-reproductive and post-reproductive ages
- C There are more males than females in each age group
- D The birth and death rate are about the same

1.4 What is the main characteristic of an age-gender pyramid for a developed country?

- A The number of newborn are high
- B There are more young people than old people
- C There are more females than males in each age group
- D The life expectancy of the population is high



**Question 2** (Adapted from Nov 2011, P2, Question 1.3.4 - 1.3.6)

Indicate whether each of the statements in COLUMN I applies to A ONLY, B ONLY, BOTH A AND B or NONE of the items in COLUMN II.

COLUMN I	COLUMN II
2.1 A relationship between different species in which both species benefit	A: Commensalism B: Mutualism
2.2 An estimation of the amount of the Earth's resources a human population, person or activity 'consumes' in a year.	A: Ecological footprint B: Simple sampling
2.3 Social organisation strategy that enhances survival	A: Dominant breeding pairs B: Division of labour

**Question 3** (Adapted from Nov 2011, P2, Question 3.1. - 3.4)

3.1 A group of Grade 12 learners wanted to use the mark-recapture technique to determine the population size of a type of fish (*Tilapia sparrmanii*) in a large dam.

Their results are shown in the table below.

	OCTOBER 2010	NOVEMBER 2010	
	Number marked and released in first sample	Number in recaptured/ second sample	Number marked in recaptured/ second sample
<i>Tilapia sparrmanii</i>	15	150	10

3.1.1 List FOUR steps that should be considered when planning to determine the population size using this investigation. (4)



3.1.2 Use the formula below to estimate the population size of *Tilapia sparrmanii* in the dam. Show ALL working.

$$P = \frac{F \times S}{M}$$

F = Number caught in the first sample

S = Number caught in the second sample

M = Number marked in the second sample

3.2 Study the graph below showing the growth of a population over a period of time

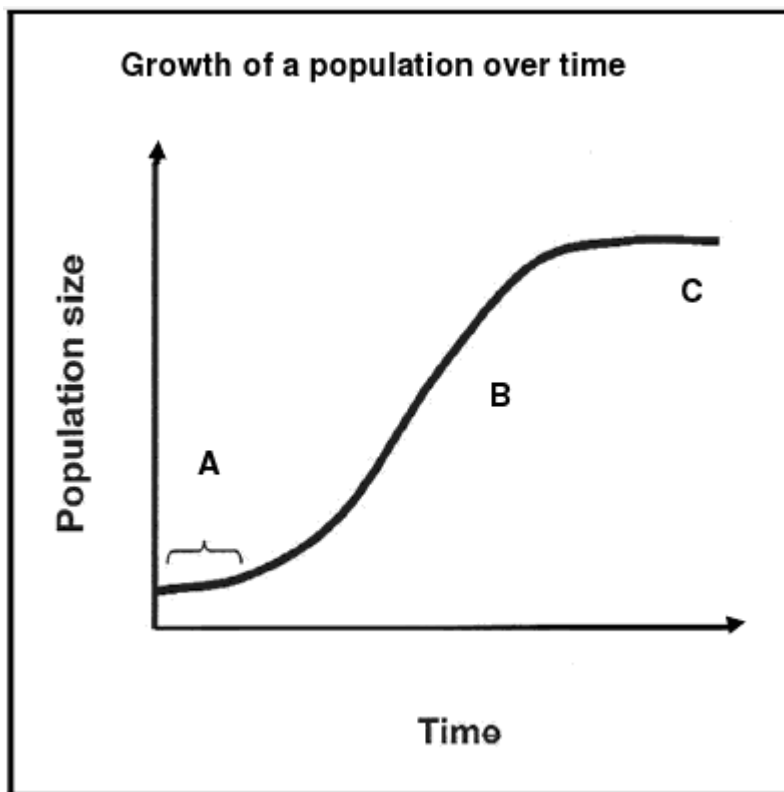

3.2.1 Identify the growth form indicated by the graph above.

3.2.2 Identify the phases labelled A, B and C.

3.2.3 Write down the letter (A, B or C) of the phase in the above graph which illustrates rapid growth.

3.2.4 Explain why the population size at C stayed constant.

3.2.5 Give TWO reasons why the population growth at A was slow.



3.3 Study the case study below and answer the questions that follow.

**TENSIONS AND ISSUES AROUND MINING AT MTUNZINI**

*Plans are in place for 2 800 ha of forestry and farming land, just outside the North Coast town of Mtunzini in KwaZulu-Natal, to be mined for minerals such as zircon, ilmenite and rutile. These valuable minerals are used in everyday products from paint, pigment and toothpaste to titanium golf clubs.*

*Tension is rising between some Mtunzini residents and the mining firm, Exxaro KZN Sands, over whether mining should take place there.*

*One group of residents accused Exxaro of being environmentally unfriendly. Another group of residents, such as amakhosi and leaders from the tribal areas, supported the project saying that mining would have positive spin-offs for the community.* [Adapted from Sunday Tribune, 15 May 2011]

- 3.3.1 Name the THREE different role players/stakeholders involved in the issue above.
- 3.3.2 State TWO advantages and TWO disadvantages of mining activities at Mtunzini.
- 3.4 Study the pictures and a graph below showing community interactions and answer the questions that follow.

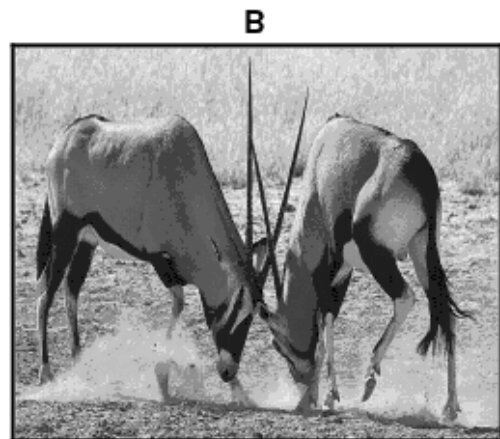
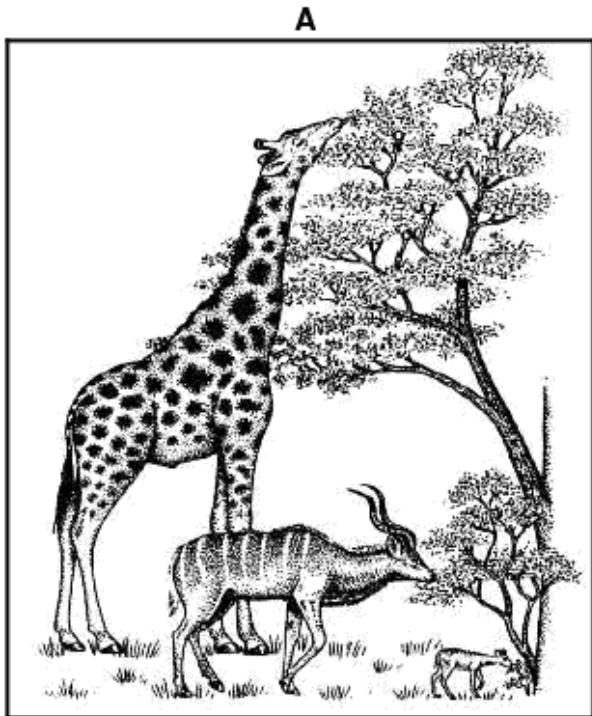





**C Changes in the population density of two *Paramecium* species in the same habitat over time**

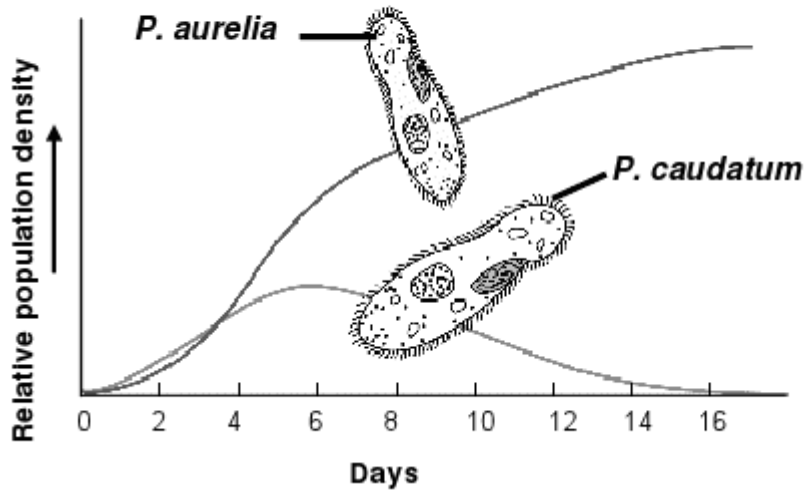

3.4.1 Name the following:

- (a) Community interaction represented in A
- (b) Type of competition represented in B
- (c) Community interaction represented in C

3.4.2 Describe the community interaction represented in A.

**Question 4** (Adapted from Nov 2011, P2, Question 2.4)

The apparatus below was set up to investigate the effect of two different environmental factors on the behaviour of woodlice (small invertebrate animals). The usual habitat of the woodlice is decaying vegetation.

The apparatus consisted of four flattened, inter-connecting covered dishes. Two of these dishes were placed in dark and two in light conditions. Moist paper was placed in one of the two dishes in the dark and one of the two dishes in the light.

Ten woodlice were placed in each of the four dishes and allowed to move freely between the dishes.



The number of woodlice present in each dish after 15 minutes is shown in the diagram below

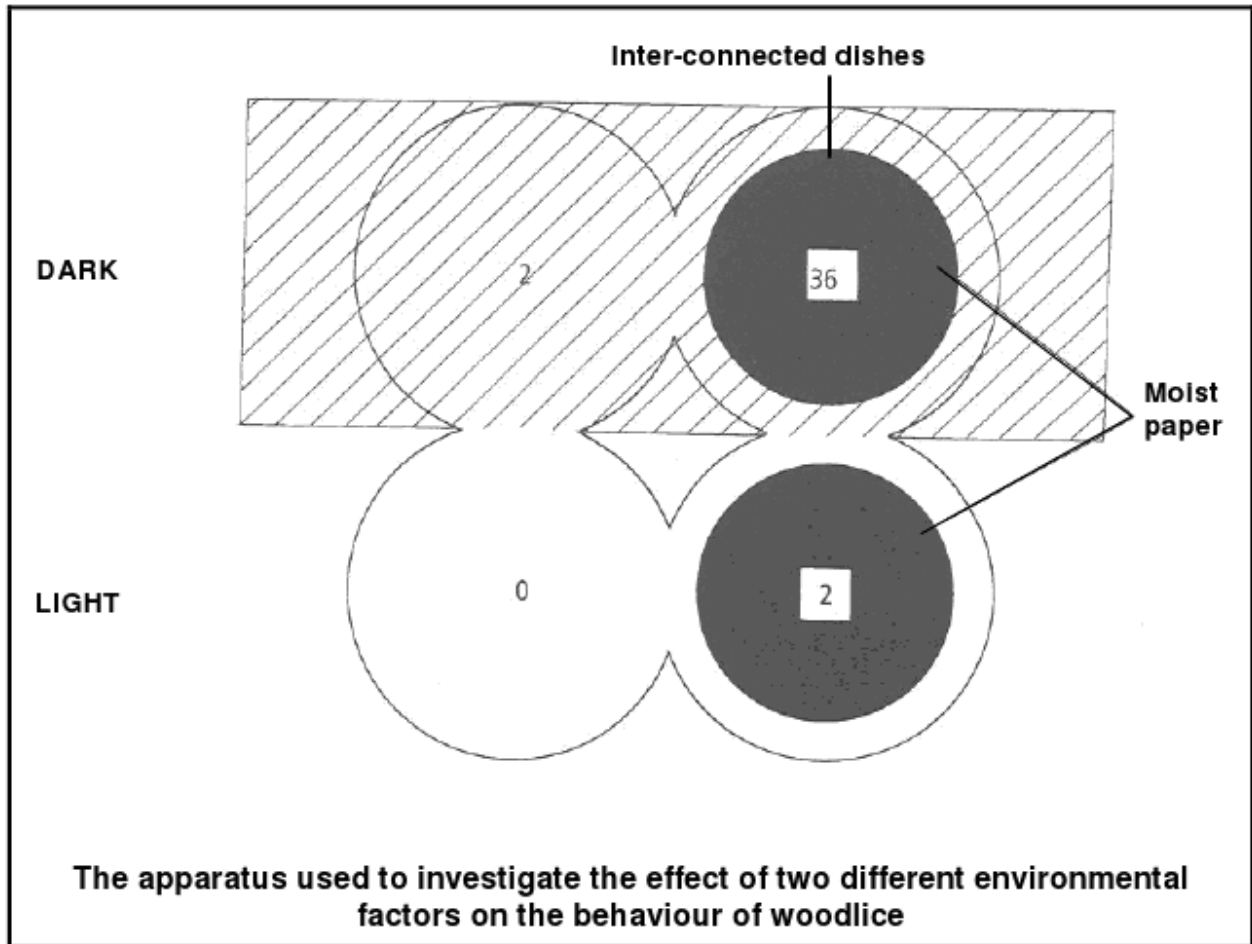

- 4.1 According to the investigation, which conditions did the woodlice prefer?
- 4.2 Explain ONE way in which the validity of this investigation could have been improved.



**Question 5** (Adapted from Nov 2011, P2, Question 4.1)

Study the table below showing changes in the human population size of the world from 1650 to 1950 and projected to 2050.

Year	Human population size (millions)
1650	500
1750	750
1850	1 000
1950	2 010
2050	8 000

5.1 Use the information in the table to plot a line graph.

5.2 From your graph determine the following:

- (a) The population size in the year 2000
- (b) The time taken for the human population to double for the first time

5.3 Give TWO reasons why it is important for any country to understand how the population will grow in the future.



## COMMUNITY STRUCTURE AND CHANGE

### Question 1 (Adapted from Nov 2011 & Feb 2012, P2, Question 1)

Various options are provided as possible answers to the following questions. Choose the correct answer.

1.1 All the organisms in a given area as well as the abiotic factors with which they interact are best described as a/an ...

- A community.
- B ecosystem.
- C habitat.
- D population.

1.2 Which of the following is an example of predation?

- A Bees visiting a flower
- B Ticks on a dog
- C A lion catching a zebra
- D A bird's nest in a tree

1.3 Which ONE of the following increases the chances of survival of a species?

- A Living individually
- B Living in a colony with division of labour
- C Having random breeding pairs
- D Hunting for prey with different species



The graph below shows the relationship between two species of mammals. Refer to this graph when answering 1.4 and 1.5

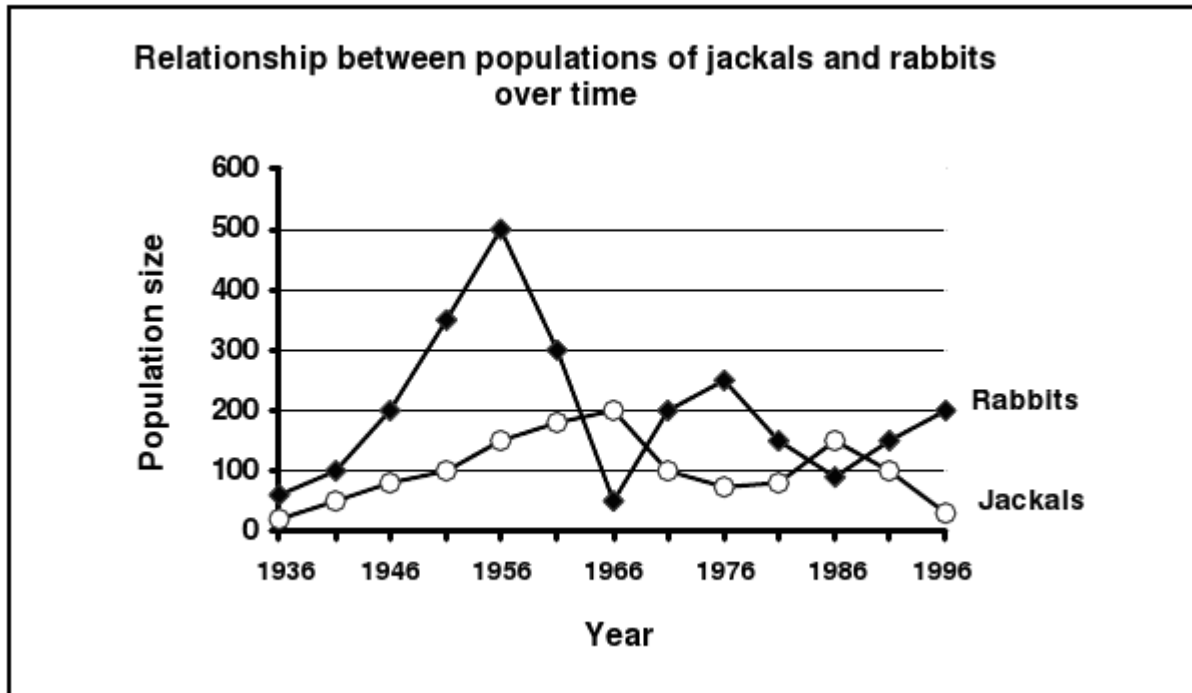

1.4 Which deduction made from the information provided in the graph is correct?

- A Species X is the predator and Y is the prey.
- B Species X and species Y are competing for the same resources.
- C Species Y is the predator and species X is the prey.
- D An increase in species X causes a decrease in species Y.

1.5 If two species in a community occupy the same niche, and resources are scarce, one will be lost due to?

- A resource partitioning
- B competitive exclusion
- C predation
- D succession



**Question 2** (*Adapted from Feb/Mar 2012, Nov 2011 & Exemplar 2011, P2, Question 1.2*)

Give the correct **biological term** for each of the following descriptions.

- 2.1 The relationship between two species in which both benefit from the association
- 2.2 The use of resources in slightly different ways by different species in the same habitat, allowing them to co-exist
- 2.3 The variety of species of living organisms that exist on Earth
- 2.4 The elimination of one species by another in a habitat as a result of dependence on a common resource
- 2.5 The killing of surplus animals by humans to avoid the destruction of the natural environment
- 2.6 The periodic movement out of and return to a habitat by living organisms
- 2.7 A group of organisms, sharing similar characteristics, which are able to interbreed to produce fertile offspring
- 2.8 A gradual change in numbers and variety of organisms living in a habitat, beginning with pioneer plants and ending with a climax community
- 2.9 Development of a community over time where species in one stage are replaced by other species

**Question 3** (*Adapted from Exemplar 2011, P2, Question 4.2*)

Read the article below on elephant culling.

***TOO HUNGRY, TOO DESTRUCTIVE, TOO MANY: SOUTH AFRICA TO BEGIN ELEPHANT CULL***

*An elephant herd at the Kruger National Park has 20 000 elephants, 5 000 more than is sustainable. Ecologists say the animals' huge appetites and fondness for 'habitat re-engineering' – reducing forests to flatland by uprooting trees and trampling plants – is the main problem.*

*Culling of the excess elephants is seen as an advantage in that it generates revenue for the communities from the sale of ivory and other elephant products. It will also provide meat to the local communities. Alternatives to culling include contraception and relocation of entire elephant families. The removal of fences between the Kruger National Park and parks in neighbouring Mozambique will eventually help with migration into less congested areas.*

*The 1998 figure of 8 000 elephant increased to 20 000 in 2008 and it is expected to reach 34 000 by 2020. [Adapted from The Guardian, 26 February 2008]*



[www.learnxtra.co.za](http://www.learnxtra.co.za)

- 3.1 Give the main reason mentioned above in support of the culling of elephants.
- 3.2 Name TWO alternatives to culling proposed above.
- 3.3 Draw a bar graph to show the change in the elephant population from 1998 to 2020.

#### Question 4

The diagram below shows some plant communities present at various time intervals on farmland cleared of vegetation by a fire.

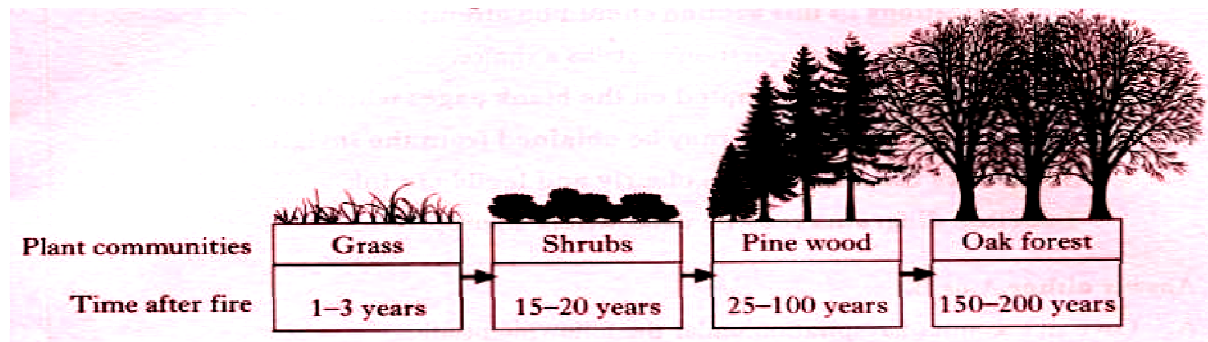

- 4.1. State the term used to describe this sequence of plant communities.
- 4.2. Give a reason to explain why the shrub community is able to replace the grass community after 15 years.
- 4.3. Oak forest is the climax community in this sequence. Describe a feature of a climax community.
- 4.4. The grid below shows the factors that can influence population change.

A	competition	B	predation	C	rainfall
D	disease	E	temperature	F	food supply

Use **all** the letters from the grid to complete the table below to show which factors are density dependent and which are density independent.

Density dependent	Density independent





### Question 5

The diagram below shows a graph which explains some of the features of population dynamics. Study the graph and answer the questions that follow.

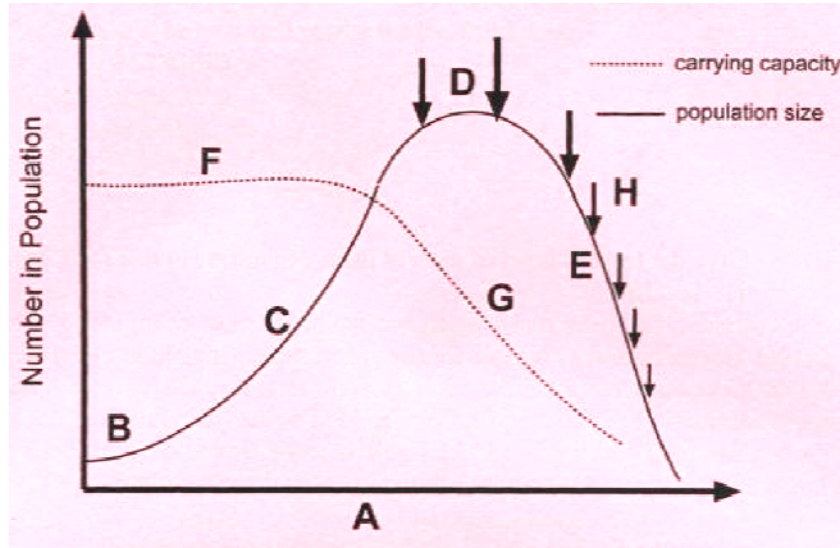

- 5.1. Give a suitable title for the horizontal axis of the graph labelled A.
- 5.2. What unit would normally be given on the X axis?
- 5.3. Which letters on the graph represent logistic growth of the population?
- 5.4. Give a suitable label for the region of the graph labelled E.
- 5.5. Explain why the curve is dropping at G.
- 5.6. What do the arrows at H represent? Explain why they are shown getting smaller towards the right of the graph.

### Question 6

Read the case study below on social organisation in meerkats and then answer the following questions.

#### **Social Organisation in meerkats**

*Meerkats are small burrowing animals that live in large underground networks with multiple entrances, which they leave only during the day. They are very social, living in colonies of 20-30 members. The individuals are usually related to one another. Animals in the same group regularly groom each other to strengthen social bonds.*

*In the colony one or more meerkats stand sentry (lookout) to warn them of approaching dangers, while others are foraging for food or playing. When a predator is spotted, the meerkat on sentry duty gives a warning bark, and other members of the colony will run and hide in one of the many bolt holes they have, spread across their territory. Sentry duty lasts about an hour. Meerkats usually retreat to their burrows when confronted by a*



*predator, although should the predator come too close to them they sometimes perform mobbing behaviour, in which a group of meerkats mob, or attacks, the predator.*

*There is a dominant male and a dominant female in each colony called the alpha pair. Usually only the alpha pair mates and kills any young not its own. The dominant couple may also evict, or kick out, the mothers of other offspring. New meerkat groups are often formed by evicted females pairing with roving males. The dominance hierarchy ensures that only one litter is born at a time and that there are an adequate number of helpers to care for the young.*

- 6.1 What bonds exist between members of a meerkat colony and how do they reinforce these bonds?
- 6.2 Identify the type(s) of social organisation displayed by meerkats.
- 6.3 Do all meerkats have the same role in a colony? Explain your answer.
- 6.4 How does the sentry meerkat benefit the colony?
- 6.5
  - a. Why does the alpha pair ensure that only one litter is born at a time?
  - b. How do they do this?
- 6.6 Name one other advantage for meerkats living in a social group

**Question 7** (*Adapted from Exemplar 2011, P2, Question 4.3*)

Using examples, describe *predation*, *competition* and *symbiosis*, explaining how each interaction influences the population size of the organisms involved.

Content: (17)

Synthesis: (3)



## SOLUTIONS TO PLANT RESPONSES TO THE ENVIRONMENT

### Question 1 (*Adapted from Exemplar 2011, P2, Question 2.3*)

- 1.1 Shoots will grow towards the light OR Shoots will grow away from the light OR Light has no influence on the shoot
- 1.2 It is the control - To verify the results of the experiment./To allow for one variable only.
- 1.3 Shoots grow towards the source of light.
- 1.4 Auxins that make the shoot to grow towards the light are in the tips of the shoots.
- 1.5 (a) Apical dominance  
(b) Tall growth of a plant/stimulate seed germination

### Question 2 (*Adapted from Nov 2011, P2, Question 4.2*)

- 2.1 The cell elongation in the coleoptiles will increase /decrease/remain the same/differ as the auxin concentration increases/decreases/differs
- 2.2 Removing the effect of auxin produced at the tip as there can be varying concentrations produced by each plant
- 2.3 Type of soil / amount of water/ light intensity/ temperature/ size of the pot/ keep environmental conditions the same
- 2.4 Increasing the concentration of auxin results in an increase in the cell elongation up to an optimum concentration then it starts inhibiting/decreasing the cell elongation.

### Question 3 (*Adapted from Feb/Mar 2012, P2, Question 4.1*)

- 3.1 Higher/Lower percentage of seeds will germinate in gibberellins solution/water than in water/gibberellin solution OR Same percentage of seeds will germinate in gibberellin solution and in water
- 3.2 Accept any value between 77 to 78%
- 3.3 Water serves as a control to verify that gibberellin does have an effect on germination /to compare results
- 3.4 The number of hazelnut seeds in both sets must be the same. / Same volume of gibberellin solution and water must be used. /Use seeds from the same plant. / Maintain the same environmental conditions. (Mark first TWO only)
- 3.5 Water is available for the seeds to germinate and grow after the heavy rain



## SOLUTIONS TO ANIMAL RESPONSES TO THE ENVIRONMENT

**Question 1** (*Adapted from Nov 2011, P2 & Exemplar 2011, P2, Question 1.1*)

- 1.1 C
- 1.2 C
- 1.3 B
- 1.4 C
- 1.5 B

**Question 2** (*Adapted from Nov 2011, P2, Question 2.1*)

- 2.1 A – Tympanic membrane ✓ / Tympanum/Eardrum  
C – Oval window ✓ / fenestra ovalis  
D – Round window ✓ / fenestra rotunda (3)
- 2.2 B – transmit vibrations ✓ from the tympanic membrane to inner ear/  
amplifies sound waves

D – prevents pressure build up of waves ✓ / absorbs pressure wave set up by tympanic canal of the inner ear/eases sound waves out of inner ear/ prevents sound waves from moving backwards in perilymph

- 2.3 Tympanic membrane/A has a larger surface area ✓ than the oval window ✓ / C

- 2.4 Ossicles will not vibrate freely ✓  
to transmit vibrations to the inner ear ✓ / causing partial deafness

**OR**

Cannot equalise pressure ✓ on either side of tympanic membrane leading to pain ✓ / middle ear infection/ a burst eardrum / vibrations not being transmitted/ partial deafness

Any (1 x 2) (2)

**Question 3.1** (*Adapted from Feb/Mar 2012, P2, Question 2.1*)

- 3.1.1 2 – cornea ✓  
3 – lens ✓  
4 – suspensory ligaments ✓  
5 – ciliary muscles /body ✓ (4)

- 3.1.2 Pupillary mechanism ✓ /Pupil reflex (1)

The radial muscles ✓ of the iris contracts ✓ and the circular Muscles ✓ relax ✓

The pupil ✓ dilates and more light enters the eye ✓ (Any 5) (5)



**Question 3.2** (Adapted from Nov 2011, P2, Question 2.2)

- 3.2.1 (a) 7 ✓ (1)
- (b) Diameter of the pupil is the largest ✓, indicating dim light conditions ✓ / allowing more light to enter (2)
- 3.2.2 Since less light enters the eye  
 - the radial ✓ muscles of the iris [contract] ✓  
 - the circular ✓ muscles of the iris [relax] ✓  
 - causing the pupil to dilate ✓ / become wider / become bigger thus allowing more light to enter any (4)  
 [ ] = **only allocate mark if linked to correct muscle**

**Question 4.1** (Adapted from Feb/Mar 2012, P2, Question 2.2)

- 4.1.1 Interneuron ✓ / connector neuron / association neuron (1)
- 4.1.2 Motor neuron ✓ (1)
- 4.1.3 The person will become aware of the stimulus ✓ but the motor neuron will not be able ✓ to transmit the impulse from the interneuron ✓ to the effector organ ✓ / muscles and movement will not take place ✓ / reaction will not occur (Max 3) (3)
- 4.1.4 Helps to protect the body ✓ by reacting quickly ✓  
 The interneuron makes a short cut ✓ / not going to the brain / uses a reflex pathway that is immediately available (Max 2) (2)

**Question 4.2** (Adapted from Nov 2011, P2, Question 1.4)

- 4.2 (a) C ✓ (1)  
 (b) B ✓ (1)  
 (c) A ✓ (1)  
 (d) B ✓ (1)  
 (e) C ✓ / D (1)

**Question 4.3** (Adapted from Feb/Mar 2012, P2, Question 4.2)

- 4.3.1 1 – pituitary ✓ gland  
 4 – adrenal ✓ gland (2)
- 4.3.2 (a) 3 ✓  
 (b) 1 ✓  
 (c) 2 ✓  
 (d) 4 ✓ (4)



- 4.3.3 They respond to internal and/or external stimuli ✓  
They protect organisms ✓  
(Mark first TWO only) (2)
- 4.3.4 Hormones: Responses are slow processes ✓ /may affect multiple sites  
Nerves: Responses are quick reactions ✓ /affect localised sites (2)

### SOLUTIONS TO REPRODUCTION

#### Question 1 (Nov 2011 P2 Q1.5)

- 1.1 C – Petal ✓/corolla      D – Anther ✓      E – Stigma ✓ (3)
- 1.2 B ✓ (1)
- 1.3 B ✓ (1)
- [5]**

#### Question 2

- 2.1. Complete ✓ All stages of development are present ✓ / egg (1/2), larva (1/2), (✓)  
pupa (1/2) and adult (1/2) (✓) stages are present (4)
- 2.2. 1 – Adult butterfly ✓  
2 – Eggs ✓  
3 – Larva ✓  
4 – Pupa ✓ (4)
- 2.3.

Complete	Incomplete
The organism <b>changes completely</b> physically, ✓ during the four life stages: <b>egg, larva, pupa and adult (imago)</b> ✓	The organism <b>changes gradually</b> physically ✓ during the three life stages: <b>egg, nymph and adult (imago)</b> ✓

(4)  
**[12]**

#### Question 3

- 3.1. Moss (1)
- 3.2. (a) Mitosis (1)  
(b) Fertilisation (1)  
(c) Meiosis (1)
- 3.3. Haploid (1)
- 3.4. No (1)
- [6]**



#### QUESTION 4

- 4.1. Amnion ✓ (1)
- 4.2. Watery fluid ✓ that protects the embryo during development ✓ (2)
- 4.3. No. 3 ✓ respiration / for waste disposal from embryo ✓ (2)
- 4.4. Chorion ✓ transfers nutrients from the albumen to the embryo ✓ (2)
- 4.5. Internal fertilisation ✓ (1)
- 4.6. **Viviparous:** the embryo develops **inside the uterus** ✓. A placenta nourishes the embryo. ✓ The female **gives birth** to **live** young ✓ when the **gestation period** is complete. ✓  
**Oviparous:** eggs with shells are **laid** ✓ outside the female's body ✓ into a nest and continue to develop in the egg ✓, **hatching** when development is complete ✓ (8)
- 4.7. **Precocial:** young are mature ✓ and able to move directly after birth or hatching ✓ They are able to fend for themselves ✓ and feed without parental care ✓ (any 3) (3)
- Altricial:** young are born helpless ✓ cannot protect ✓, feed themselves ✓ or fend for themselves ✓ (any 3) (3)
- [22]

#### Question 5

5.1.

- Seeds are an important source of food for humans, animals and birds. ✓
  - Peas, soya beans, lentils, oats, nuts and green beans are a rich source of proteins. ✓
  - Cereals, like wheat, maize and rice, are the staple diet food for many people and are often grown as a monoculture. ✓
  - Sorghum is used in the production of traditional and commercial beer. ✓
  - Sunflower and peanut seeds are used to produce cooking and salad oils. ✓
- (any 4) (4)

5.2.

- Rhizomes ✓ e.g. ✓ grasses or any relevant example ✓
- Tubers ✓ e.g. the potato / sweet potato ✓
- Bulbs ✓ e.g. the onion or any other relevant example ✓
- Stolons /runner ✓ e.g. strawberry plants / Hen and Chicken plant or any other relevant example ✓ (4x2) (8)





5.3.

	Sexual reproduction	Asexual reproduction
<b>Advantage</b>	<ul style="list-style-type: none"> <li>The recombination of the chromosomes during <b>meiosis</b> ✓ and the random fusion of gametes during fertilisation ✓ results in offspring that show <b>genetic variation</b> ✓</li> </ul>	<ul style="list-style-type: none"> <li>Asexual reproduction is ideal for producing large numbers ✓ of identical offspring ✓ with <b>desirable genetic characteristics</b>, from one selected parent ✓</li> </ul>
<b>Disadvantage</b>	<ul style="list-style-type: none"> <li>Male and female gametes may be prevented from fusing – so no offspring will be produced ✓</li> <li>Genetic mutations may result in undesired characteristics in the offspring ✓</li> </ul>	<ul style="list-style-type: none"> <li>Offspring are identical to the parent and show <b>no genetic variation</b> ✓</li> </ul>

Plus 1 mark for correct headings/table

(10)

5.4.

- Self-pollination** is the transfer of pollen from the anther to a receptive stigma of the **same flower** ✓ or the receptive stigma of a **flower on the same parent plant** ✓
- Cross-pollination** is the transfer of pollen from the anther of one plant to the receptive stigma of a flower on **another plant** ✓ of the same species. (3)

[25]

## SOLUTIONS TO HUMAN REPRODUCTION

### Question 1 (Nov 2011 P2 Q2.3)

- 1.1 Day 14 ✓ / 15 (1)
- 1.2 Day 0–6 ✓ / day 0–7 (1)
- 1.3 Stimulates follicle ✓ / ovum development in the ovary / secretion of oestrogen (1)
- 1.4 An increase in progesterone level ✓ inhibits the release of FSH ✓

**OR**

- FSH stimulates the development of the ovum ✓ and progesterone prepares for implantation ✓ when this ovum is fertilised (2)
- 1.5 - Corpus luteum ✓  
- starts to secrete progesterone ✓  
- which thickens ✓ the lining of the uterus wall / endometrium any (2)
- 1.6 No ✓ (1)
- 1.7 - Corpus luteum has degenerated ✓  
- Progesterone level has decreased ✓  
- FSH level starts to rise ✓  
- LH level decreases ✓ (2)

**(Mark first 2 only)**

(2)



**Question 2**

- 2.1 A- Ovary ✓, E- Fallopian tube ✓, G- endometrium ✓, (3)  
 2.2 Ovulation ✓ (1)  
 2.3 Day 14/middle of the menstruation cycle ✓ (1)  
 2.4 Fertilisation ✓, takes place. The sperm ✓(haploid/n) fuses with the (haploid/n) egg cell/ovum ✓to form a diploid zygote (2n) ✓ **(any 3 points)** (3)  
 2.5 a) 23 chromosomes ✓ (1)  
 b) 46 chromosomes ✓ (1)  
 c) 23 chromosomes ✓ (1)  
**[11]**

**Question 3**

- 3.1. A Placenta ✓  
 B Umbilical cord ✓  
 D Vagina ✓ (3)  
 3.2 - Acts as a shock absorber ✓  
 - Regulates embryo's body temp / keeps temp constant ✓ (2)  
 3.3. Amniocentesis ✓ (1)  
 3.4. Oxytocin released by posterior lobe of Pituitary gland ✓. Causes uterine contractions, push baby out through the birth canal. ✓ (2)  
**[8]**

**Question 4**

- 4.1. The pill ✓ is the most commonly used contraceptive in the community ✓ (2)  
 4.2. Design a questionnaire. ✓ (1)  
 4.3. The pill and injections ✓✓ (2)  
 4.4. Condom ✓✓ (2)  
 4.5. Survey of different types of contraception

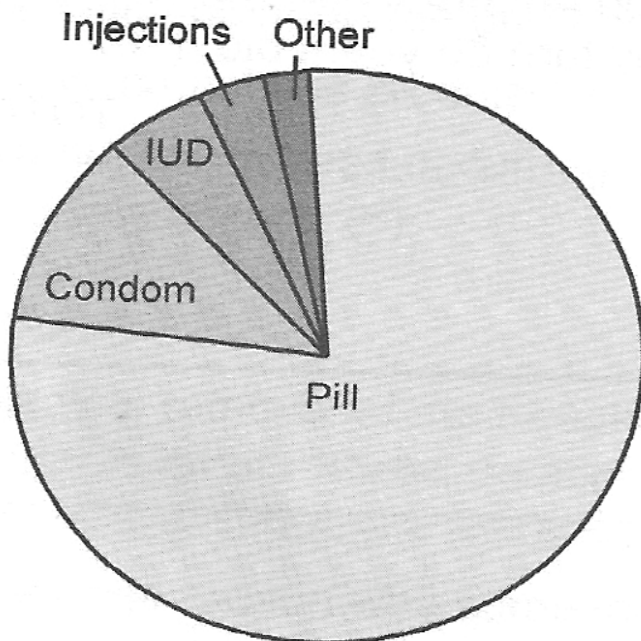

Pill: 86.4%:  
 $86.4 \times 360 = 31104/100 = 311^0$

IUD: 3.1%:  
 $3.1 \times 360 = 1116/100 = 11^0$

Condoms: 6.4%:  
 $6.4 \times 360 = 2304/100 = 23^0$

Injections: 2.2%:  
 $2.2 \times 360 = 792/100 = 8^0$

Other: 1.8%:  
 $1.8 \times 360 = 648/100 = 7^0$



Calculations	1 mark for each calculation (5)
Correct type of graph	1
Title / heading is correct	1
Correct proportions for each slice	1 mark for each slice (5)
Each sector is labelled or a key is given	1
Each amount/percentage is indicated on the graph	1

(14)  
[21]

**Question 5**

- 5.1. D
- 5.2. J
- 5.3. F
- 5.4. K
- 5.5. B
- 5.6. G
- 5.7. E
- 5.8. H
- 5.9. M
- 5.10. I

[10]

**SOLUTIONS TO POPULATION ECOLOGY**

**Question 1** (*Adapted from Nov 2011, P2, Question 1.1.7 - 1.1.10*)

- 1.1 B
- 1.2 C
- 1.3 B
- 1.4 D

**Question 2** (*Adapted from Nov 2011, P2, Question 1.3.4 - 1.3.6*)

- 2.1 B only
- 2.2 A only
- 2.3 Both A and B

**Question 3** (*Adapted from Nov 2011, P2, Question 3.1. - 3.4*)

- 3.1.1- Obtain permission to catch fish/use dam
- Conduct training to identify the *Tilapia sparrmanii*
- Decide when to do the investigation
- Decide on the tags /markers/apparatus to be used
- Decide on the method of catching
- Determine the sample size /number of repeat samples
- Determine the period between the two successive captures
- Decide on how to record the results



3.1.2

$$\begin{aligned} \text{Number of } \textit{Tilapia sparrmanii} (P) &= \frac{(15 \times 150)}{10} \checkmark \\ &= 225 \checkmark \end{aligned}$$

3.2.1 Logistic growth form/S-shaped/sigmoid

3.2.2 A = Lag /Establishment phase

B = Exponential /Geometric/accelerating/log/logarithmic phase

C = Equilibrium /Stationary/Stabilising/Constant phase

3.2.3 B

3.2.4 - Environmental resistance increased

- causing the carrying capacity of the area to be reached
- leading to increased competition
- resulting in the death rate increasing to equal the birth rate
- or resulting in increased emigration that balances with immigration

3.2.5 - Population is acclimatising/adapting to its new environment

- Few pairing partners
- Time required for producing offspring is relatively long
- Not all individuals are sexually mature

3.3.1 Residents / Mining company /Exxaro KZN Sands / Amakhosi and tribal leaders

3.3.2 **Two advantages**

- Creating new jobs
- Job reservation/job losses prevented
- Contribute to the economy of the town /income to municipality from tax rates will increase through businesses
- Minerals available more cheaply
- Develops infrastructure of the town

**Two disadvantages**

- Health implications
- Decrease of the property values of the residents
- Income to municipality from tax rates will decrease through decline in property value
- Exploitation of the community
- Loss in biodiversity
- Increase in pollution
- Environmental degradation
- Conflict in the community

3.4.1 (a) Resource /Spatial/niche partitioning

(b) Intraspecific competition

(c) Competitive exclusion principle/interspecific competition



3.4.2 - Different species

- coexist in the same habitat
- eating leaves of plant at different heights /use the resourceslightly differently
- minimising competition

**Question 4** (Adapted from Nov 2011, P2, Question 2.4)

4.1 Moist and dark conditions

4.2 - The other two dishes should have had dry paper put in so that all the four dishes had the same paper / to avoid introducing a new variable

- Test one variable at a time/light and moisture conditions separately to determine which environmental factor was preferred by the woodlice
- Repeat the investigation to increase reliability
- Ensure sufficient time for the movement of the woodlice
- Use the same species /sex/age of woodlice as they might behave differently /this avoids the introduction of a new variable

**Question 5** (Adapted from Nov 2011, P2, Question 4.1)

5.1

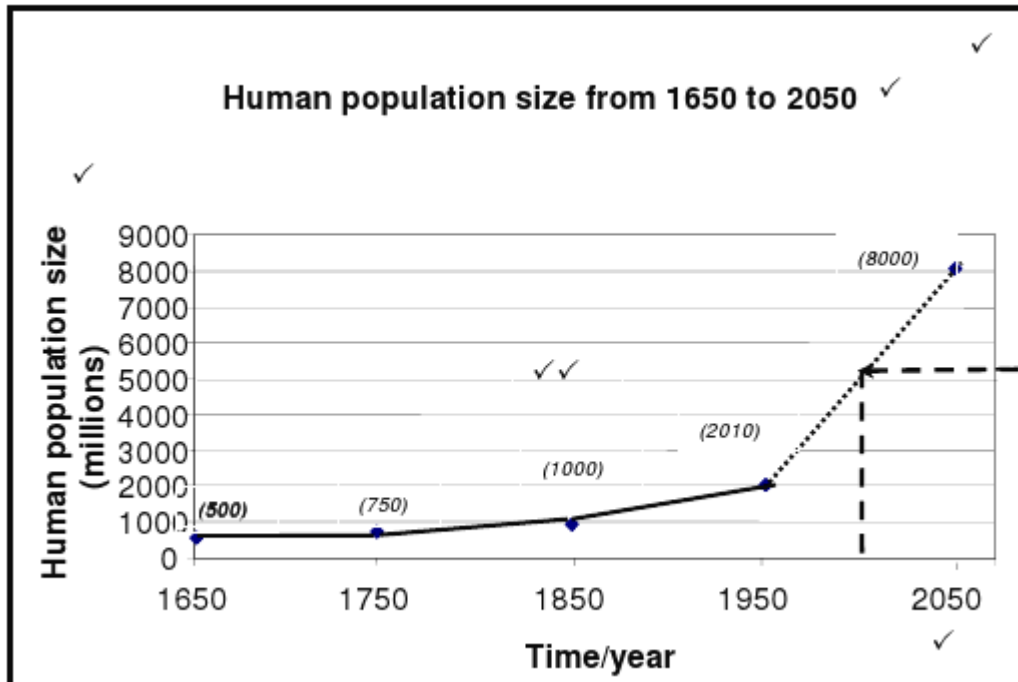

5.2 (a) Read from the learners graph 5200 million

(b) 200 years

5.3 To budget for infrastructure development e.g. housing

To plan for services in the future e.g. education

To have strategies / any example to improve the sustainability of the environment





## SOLUTIONS TO COMMUNITY STRUCTURE AND CHANGE

**Question 1** (Adapted from Nov 2011 & Feb 2012, P2, Question 1)

- 1.1 B
- 1.2 C
- 1.3 B
- 1.4 C
- 1.5 B

**Question 2** (Adapted from Feb/Mar 2012, Nov 2011 & Exemplar 2011, P2, Question 1.2)

- 2.1 mutualism
- 2.2 resource partitioning
- 2.3 biodiversity
- 2.4 competitive exclusion
- 2.5 culling

**Question 3** (Adapted from Exemplar 2011, P2, Question 4.2)

- 3.1 Elephants cause damage to the environment
- 3.2 Contraception / relocation of elephant to different areas / Removing fences to allow migration
- 3.3

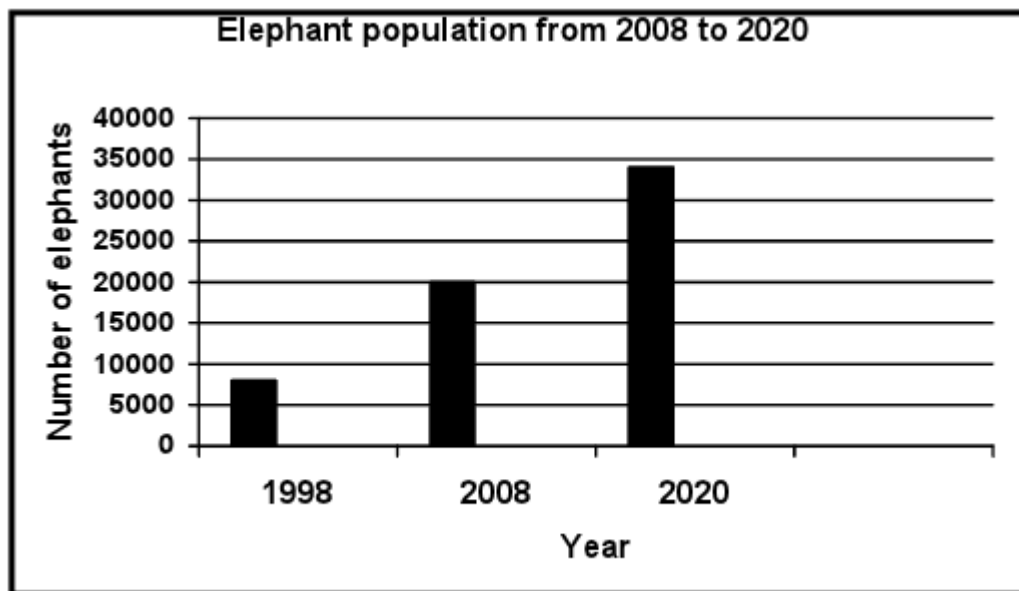

**Question 4**

- 4.1 Succession
- 4.2 Grass establishes the environment in the pioneer phase, grass then decomposes over a period of time and contributes to the fertility of the soil and establish the conditions required for the shrubs to be able to survive.





4.3 Taller, deeper root system

Greater ability to absorb sunlight →

Complex reproductive pattern including formation of seeds

4.4

Density dependent	Density independent
A, B, D, F	C, E

**Question 5**

5.1 Time

5.2 Years for large animals Minutes for bacteria

5.3 C

5.4 Negative growth phase

5.5 Increasing environmental  
Population exceeds the carrying capacity.

**Question 6**

6.1 There is social bonding within the meerkat community. They are related to each other. These bonds are strengthened by grooming

6.2 Division of labour e.g. The role of the sentry

Breeding hierarchy e.g Dominant male and female in the community

6.3 No there are different roles played by different meerkats e.g sentry, dominant male and female

6.4 Warns the other members of the colony of approaching danger. Protects the colony.

6.5 a. There is only one litter born at a time from the dominant male and female. To ensure that there is enough food to sustain the pups and the colony. Promotes the strongest genes.

b. Other females who are of breeding age are excluded from the colony. Dominant male and female kill young of other breeding pairs

6.6 Hunt together and share food.

**Question 7**

**Predation**

A predator captures and kill other animals (prey) for its food

Example: Lions that capture and feed on antelopes

Prey population will decrease and the predator population will increase

(3)

**Competition**

Interspecific competition

Happens when large numbers of organisms of different species depend on same resources.

Example: Flour beetles



One species will decrease in population size while the other will increase

**OR**

Intraspecific competition

Happens between organisms of same species that share the same available resource.

Example: Owls competing for same resources. Stronger owls will survive

The owl population will decrease

(3)

**Symbiosis** is the close association between two organisms so that one or both benefit

**Parasitism**

One organism benefit (parasite) while the other is harmed (host)

Example: Tapeworm and humans

The host organisms population size will decrease and the parasite population increase

(4)

**Mutualism**

Symbiotic relationship between two organisms in which both benefit

Example: Bacteria and roots of leguminous plants

Both populations will increase

(4)

**Commensalism**

Symbiotic relationship between two organisms in which one benefits without harming the other.

Example: Sharks and sucker fish/Remora (benefit)

The population size of the organism that benefits will increase in size

(4)