

Further Education and Training

Grade 12 (FET)

BRIGHT IDEAS

LIFE SCIENCES

Revision Booklet



basic education
Department:
Basic Education
REPUBLIC OF SOUTH AFRICA



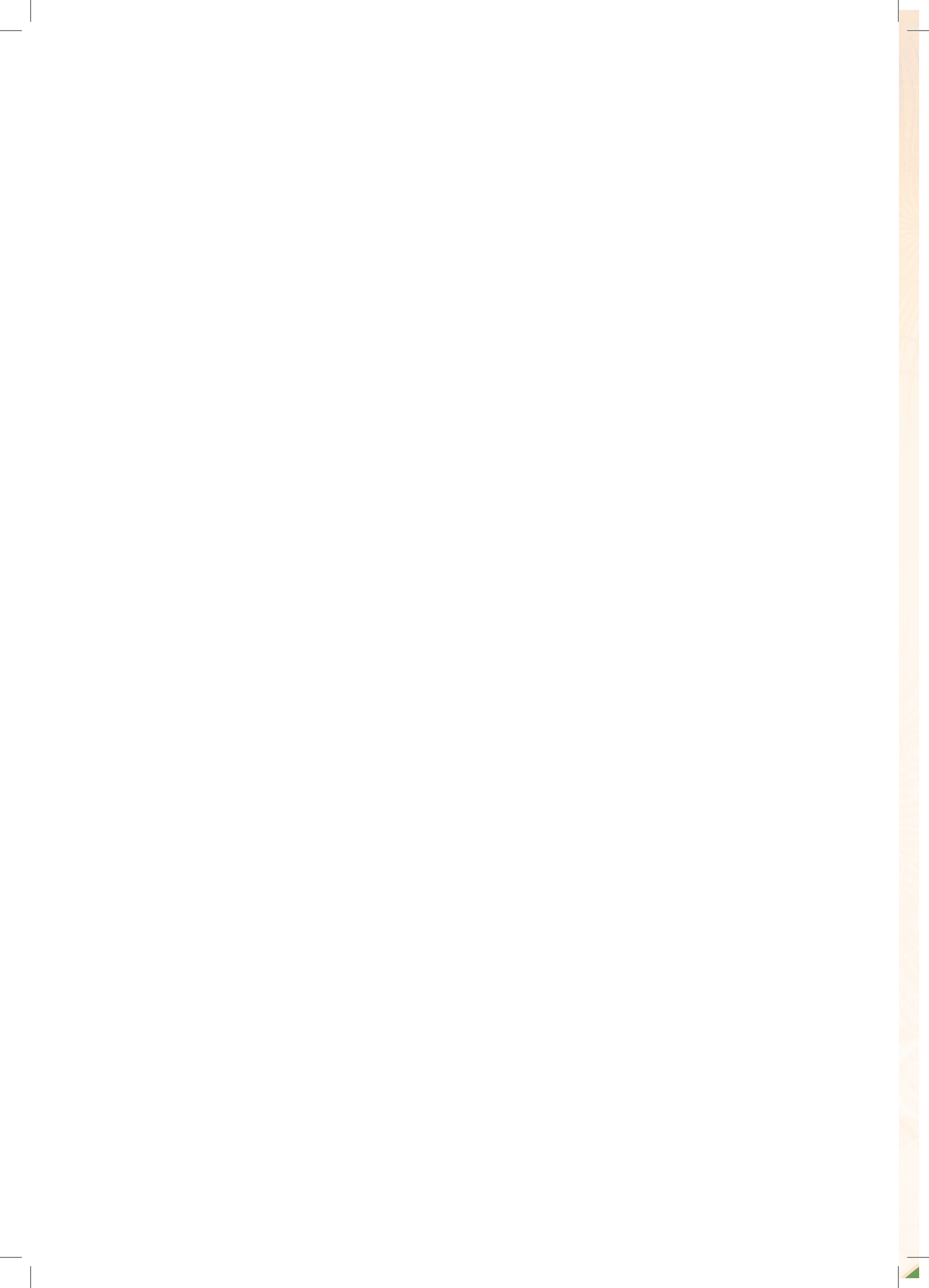

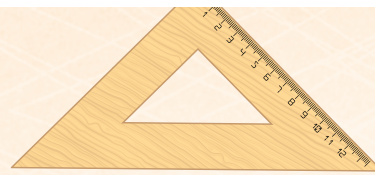

Life Sciences

Grade 12

REVISION BOOKLET

32%



History
Mathematics



Physics
Accounting

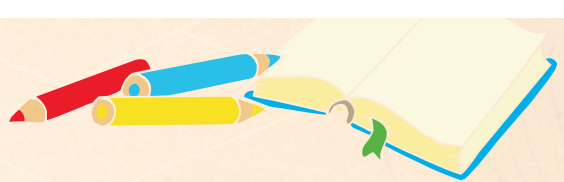
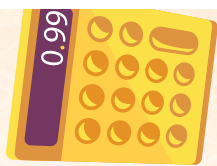
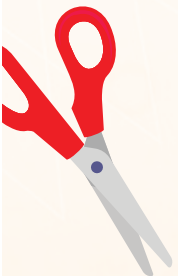
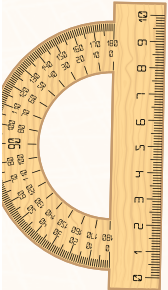

TABLE OF CONTENTS

PAGE

1	FOREWORD	3
2	HOW TO USE THIS REVISION BOOKLET	4
3	KEY LIFE SCIENCES CONCEPTS	5
4	REVISION QUESTIONS SET 1 (MASTER 40%)	21
5	CHECK YOUR ANSWERS SET 1 (MASTER 40%)	56
6	REVISION QUESTIONS SET 2 (MASTER AN ADDITIONAL 20%)	70
7	CHECK YOUR ANSWERS SET 2	83
8	THANK YOU	99





1 FOREWORD

Message from the Minister of Basic Education

Message to Grade 12 learners from the Minister of Basic Education



“Matric” (Grade12) is perhaps the most important examination you will prepare for. It is the gateway to your future; it is the means to enter tertiary institutions; it is your opportunity to create the career of your dreams.

It is not easy to accomplish but it can be done with hard work and dedication; with prioritising your time and effort to ensure that you cover as much content as possible in order to be well prepared for the examinations.

I cannot stress the importance and value of revision in preparing for the examinations. Once you have covered all the content and topics, you should start working through the past examination papers; thereafter check your answers with the memoranda. If your answers are not correct, go back to the *Mind the Gap Series* and work through the content again. Retest yourself. Continue with this process until you get all the answers right.

The ***Bright Idea....getting exam ready Booklet*** will allow you to do this in a systemic way. It has been developed to assist you to achieve a minimum of 40% in the examinations, if you work hard and follow the advice and guidance provided in the book. I also urge you to continue with the next section that deals with an additional 20%, which will ensure you have covered the basics to achieve 60%.

Use this valuable resource which has been developed especially for YOU, work hard, persevere, work every day, read and write every day to ensure that you are successful.

I have faith that you can do this. Remember “SUCCESS” depends on the second letter, “U”.

Best Wishes

**MRS AM MOTSHEKGA, MP
MINISTER OF BASIC EDUCATION**

DATE: 24/02/2017



32%



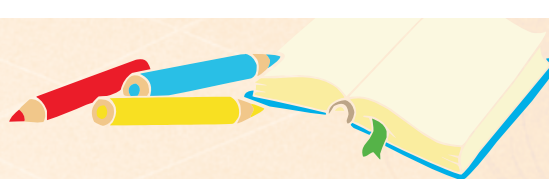
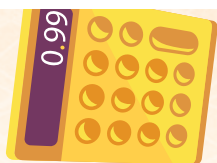

2 HOW TO USE THIS REVISION BOOKLET

- You must use this Revision Booklet together with the *Life Sciences Mind the Gap Study Guide*, which is a complementary booklet.
- You need to study the content in *Mind the Gap* (MTG) for all the topics.
- Ensure you understand all the relevant concepts and content.
- This Revision Booklet focusses mainly on the skills you need to answer the questions in the examinations.
- Section 3 focusses on general tips about how to approach certain types of questions in the Life Sciences papers:
 - how to answer multiple-choice questions
 - how to master the relevant terminology
 - answering matching questions
 - drawing and interpreting graphs
 - interpreting tables
 - interpreting diagrams
 - doing calculations
 - writing essays in Life Sciences
- Section 4 includes the following:
 - Examples of remembering questions in each paper per topic.
 - Tips on how to approach answering these questions.
 - References to how to link the questions to MTG.
 - Practice questions per topic are provided.
- Section 5 provides the answers to the practice questions in Section 4. You are urged NOT to look at the answers until after you have answered the questions on your own first. Then check your answers against the answers provided. You may have to revisit the content.
- Section 6 includes the following:
 - Examples of questions that test understanding are given per topic for each paper.
 - Tips are provided on how to approach answering these questions.
 - References to how to link the questions to MTG study guides.
 - Practice questions per topic.
- Section 7 provides the answers to the practice questions in Section 6. You are urged NOT to look at the answers until after you have answered the questions on your own first. Then check your answers against the answers provided. You may have to revisit the content.
- Section 8 provides study and exam tips.



3 KEY LIFE SCIENCES CONCEPTS

3.1 GENERAL TIPS TO APPROACHING CERTAIN TYPES OF QUESTIONS IN THE LIFE SCIENCES QUESTION PAPERS

3.1.1 Multiple-choice

This question type is found in section A of the paper. Every multiple question starts with a stem in the form of a statement or question. Four possible answers are given, from which you have to choose the correct one.

When answering multiple-choice questions:

1. **Read the stem and cover/block the four possible answers. (Don't look at the answers at this stage.)**
2. *Think about the question and think of the correct answer.*
3. *Then uncover the 4 possible answers.*
4. *If you see your answer, circle the LETTER.*
5. **Look at the other possible options to check that none of the other options is a better option than the one you have chosen.**
6. **If you do not see your possible answer, then cross out the 3 options that you think are probably incorrect.**
7. **NEVER** leave a multiple-choice question **UNANSWERED**.

EXAMPLE

(DBE, November 2016, Paper 1)

1. THE PART OF THE BRAIN THAT RECEIVES NERVE IMPULSES FROM THE SEMI-CIRCULAR CANALS IS THE ...

- (b) cerebrum.
- (c) cerebellum.
- (d) hypothalamus.
- (e) medulla oblongata.

Stem: This refers to the question.

REMEMBER: The semi-circular canals are structures found in the human ear and they play a role in balance. The cerebellum in the brain controls balance.

Answer: Therefore the correct answer is option **B**. **Why are the other options incorrect?** The cerebrum is responsible for interpreting the senses (e.g. hearing) and not for balance. The hypothalamus is responsible for most homeostatic control mechanisms (e.g. thermoregulation). The medulla oblongata controls involuntary actions (e.g. heart beat).



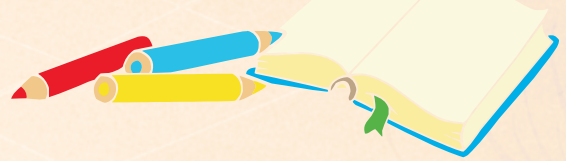
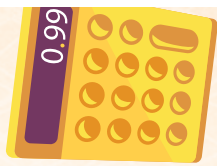

(DBE, June 2015, Paper 2)

1. WHICH ONE OF THE FOLLOWING IS TRUE ABOUT GENES? GENES ARE ...

- (a) codes for a particular characteristic.
- (b) made up of amino acids.
- (c) made up of RNA.
- (d) found in a ribosome.

Stem: This refers to the question.
REMEMBER: A gene is a segment of DNA /a chromosome that is responsible for a particular characteristic e.g. attached or unattached earlobes.
Answer: Therefore the correct answer is option A. **Why are the other options incorrect?**
 Proteins are made up of amino acids. Genes are made up of DNA and NOT RNA. DNA is found in the nucleus and mitochondria and NOT in the ribosome.

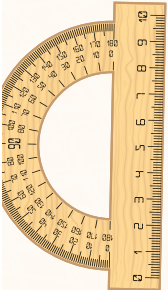

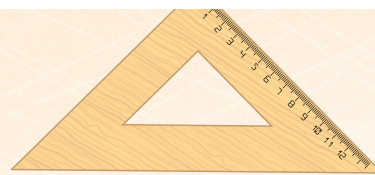

3.1.2 Terminology

Understanding terminology is key to understanding Life Sciences. You need to understand the biological terms in order to be able to understand the question and to have the necessary vocabulary to answer the questions. Most of the key concepts can be found in the *MTG* booklets. Some of the biological terms you need to know are listed below:

Paper 1

Biological term	Description / Explanation
Abscisic acid	The plant growth hormone that promotes seed dormancy.
Accommodation	The series of changes that take place in the shape of the lens and the eye-ball in response to the distance of an object from the eye.
Aldosterone	A hormone that regulates the salt concentration in human blood.
Allantois	The structure in the amniotic egg that stores wastes.
Altricial development	The reproductive strategy in which hatchlings of birds are not able to move and feed themselves.
Aqueous humour	The watery fluid that supports the cornea and the front chamber of the eye.
Autonomic nervous system	The part of the peripheral nervous system that controls involuntary action.
Biodiversity	The variety of plant and animal species on earth.
Carbon footprint	Measurement of the total amount of carbon dioxide emissions of an individual per year.
Centrosome	Organelle found only in animal cells that forms the spindle during cell division.
Centriole	Structures formed when the centrosome divides into two, and move to opposite poles of the cell during cell division.
Chiasma	The point where two chromatids overlap during crossing over.
Choroid	A layer inside the eye that absorbs light, thus reducing reflection.
Chorion	The outermost membrane found around the embryo/foetus.
Cristae	The receptors in the ear that detect changes in the direction and speed of any movement of the body.
Cytokinesis	The division of the cytoplasm through the constriction of the cell membrane at the end of cell division.
Deforestation	Removal of large numbers of trees from an area.
Endometrium	The inner lining of the uterus where implantation of the embryo occurs.
Eustachian tube	The part of the ear that equalises the pressure on either side of the tympanic membrane.
Eutrophication	The accumulation of nutrients in water bodies from over-use of fertilisers on land, which stimulates excessive plant growth.
External fertilisation	A type of fertilisation in which the nucleus of a sperm fuses with the nucleus of an ovum outside the body of the female.
Fallopian tube	Part of the female reproductive system where fertilisation occurs.
Food security	Access by all people, at all times, to adequate, safe and nutritious food.
Geotropism	The growth of part of a plant in response to gravity.
Greenhouse effect/Enhanced greenhouse effect	Heat being trapped by a layer of greenhouse gases (e.g. carbon dioxide, methane) surrounding the earth. The enhanced greenhouse effect is a result of large-scale release of greenhouse gases surrounding the earth, thereby causing global warming.
Grommets	Small tubes placed in the tympanic membrane to drain liquid from the middle ear.



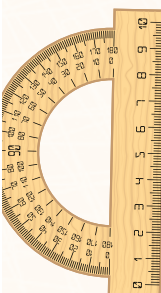
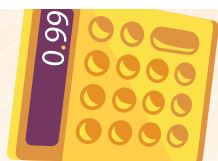

Biological term	Description / Explanation
Homeostasis	The maintenance of a constant internal environment in the body within certain limits.
Internal fertilisation	A type of fertilisation in which the nucleus of a sperm fuses with the nucleus of an ovum inside the reproductive system of the female.
Interphase	The phase in the cell cycle when DNA replication occurs.
Long-sightedness	A defective condition of the eye that means that a person can see distant objects clearly while nearby objects are blurred.
Luteinising hormone/LH	The hormone responsible for ovulation and the formation of the corpus luteum.
Medulla oblongata	The part of the brain that controls heart rate.
Meninges	A collective name for the membranes that protect the brain.
Oestrogen	The hormone that causes thickening of the endometrium and is produced by the Graafian follicle.
Oval window	The membrane that transmits sound vibrations to the inner ear.
Ovipary	The reproductive strategy that involves laying eggs.
Ozone/O ₃	A layer in the atmosphere that is damaged by chlorofluorocarbons (CFCs).
Phototropism	The growth of part of a plant in response to light.
Pinna	The part of the human ear that directs sound waves into the auditory canal.
Precocial development	The reproductive strategy in which hatchlings of birds are able to move and feed themselves.
Puberty	The stage in humans when sexual maturity is reached in males and females.
Retina	The innermost membrane in the eye that contains photoreceptors.
Short-sightedness	A defective condition of the eye which means that a person can see nearby objects clearly while distant objects are blurred.
Stimulus	A detectable change (e.g. pain, heat, light, sound) that will be received by a receptor and converted into an impulse.
Testosterone	A hormone that stimulates the maturation of sperm and stimulates puberty in males.
Thermal pollution	The type of pollution caused when water is released into a river after being heated in power stations or other industries.
TSH/Thyroid-stimulating hormone	A hormone that stimulates the secretion of thyroxin.
Vas deferens	The male reproductive tube that connects the testis with the urethra.
Vasoconstriction	Narrowing of the blood vessels in the skin in humans, which decreases the amount of blood flowing to the skin when the environmental temperature is low.
Vasodilation	Widening of the blood vessels in the skin in humans, which increases the amount of blood flowing to the skin when the environmental temperature is high.
Vivipary	A type of reproduction, including in humans, in which the foetus develops inside the uterus.





Paper 2

Biological term	Description
Albinism	The condition that results from the absence of skin pigmentation.
Alleles	Two alternative forms of a gene at the same locus.
Binocular	Using two eyes with overlapping fields of view to create a single visual image.
Biodiversity	The variety of life forms that exist on Earth.
Biogeography	The distribution of species in different parts of the world.
Bipedalism	The ability of an organism to walk on two limbs.
Clone	A copy of an organism that is genetically identical to the original organism.
Cloning	The process by which genetically identical organisms are formed using biotechnology.
Co-dominance	The type of inheritance where both alleles are equally dominant and both express themselves equally in the phenotype. E.g. a white cow crossed with a black bull will produce a calf with black and white patches.
Complete dominance	The type of inheritance in which the dominant allele masks the expression of the recessive allele in the heterozygous condition.
Dihybrid	A genetic cross involving two different characteristics, e.g. shape and colour of seeds.
DNA profile	A bar code pattern formed from DNA that is unique to each person/organism.
Down syndrome/trisomy 21	A human disorder caused by non-disjunction of chromosome pair number 21.
Extinction	The permanent disappearance of a species from earth.
Foramen magnum	The opening at the base of the skull through which the spinal cord enters.
Gene	A segment of DNA/a chromosome that contains the code for a particular characteristic.
Genome	The complete set of chromosomes in the cell of an organism.
Haemophilia	A sex-linked genetic disorder characterised by the absence of a blood-clotting factor.
Hominidae/Hominids	The family to which humans belong.
Homologous structures	Similar structures on different organisms that suggest they have a common ancestor.
Homologous chromosomes	Two chromosomes that carry the same set of genes.
Hydrogen bond	The weak bond between nitrogenous bases in a DNA molecule.
Hypothesis	A tentative explanation of a phenomenon that can be tested and which may be accepted or rejected.
Incomplete dominance	The type of inheritance in which both alleles express themselves in such a way that an intermediate phenotype is formed. E.g. a white flowering plant crossed with a red flowering plant will produce a pink flowering plant.
Karyotype/Karyogram	A representation of the number, shape and arrangement of all the chromosomes in the nucleus of a somatic cell.
Locus	The position of a gene on a chromosome.



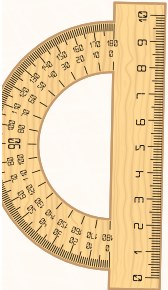
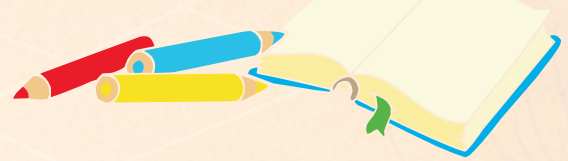
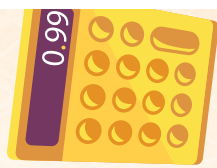

Monohybrid cross	A genetic cross involving one characteristic, e.g. the colour of seeds.
Natural selection	The process by which organisms best suited to survival in the environment achieve greater reproductive success, thereby passing advantageous characteristics onto future generations.
Non-disjunction	The process in which homologous chromosome pairs fail to separate during meiosis.
Nuclear pores	Openings in the nuclear membrane that allow mRNA to leave the nucleus.
Out of Africa hypothesis	The hypothesis that states that modern humans/ <i>Homo sapiens</i> originated in Africa and migrated to other parts of the world.
Peptide bond	The name of the bond that forms between amino acids in a protein molecule.
Phylogenetic tree/cladogram	A diagrammatic representation showing possible evolutionary relationships among different species.
Population	A group of organisms of the same species living in the same habitat at the same time.
Quadrupedal	The ability of an organism to walk on four limbs.
Replication	The process by which a DNA molecule makes identical copies of itself.
Ribosome	The organelle in the cytoplasm that is the site of protein synthesis.
Speciation	A process whereby new species are formed from the original population.
Species	A group of organisms that can interbreed to produce fertile offspring.
Spindle fibres	The structure responsible for pulling chromosomes to the poles of a cell during cell division in animals.
Stereoscopic vision	The type of vision that allows for depth perception and 3-dimensional vision.
Transcription	The stage of protein synthesis during which mRNA forms from DNA.
Translation	The stage of protein synthesis during which tRNA interprets the message on the mRNA to form a specific protein.
tRNA/transfer RNA	The type of nucleic acid that carries a specific amino acid.





3.1.3 Matching columns

This question type is found in section A in the paper. Normally a key is provided that is to be used to present your answer to the question.

Every question starts with a description or statement. TWO possible answers are provided.

When answering this question:

1. Read the description and each possible answer separately.
2. If the possible answer is correct, make a \checkmark next to the possible answer. If the possible answer is incorrect, make an **X** next to the possible answer.
3. Use the key to present your answer.



EXAMPLE

(DBE, June 2015, Paper 1)

Indicate if each of the statements in COLUMN I applies to **A ONLY**, **B ONLY**, **BOTH A AND B** or **NONE** of the items in COLUMN II. Write **A only**, **B only**, **both A and B** or **none** next to the question number.

COLUMN I		COLUMN II	
1.	A young bird is helpless soon after hatching.	A:	Precocial development X
		B:	Altricial development \checkmark

(DBE, November 2015, Paper 2 (2))

Indicate if each of the statements in COLUMN I applies to **A ONLY**, **B ONLY**, **BOTH A AND B** or **NONE** of the items in COLUMN II. Write **A only**, **B only**, **both A and B** or **none** next to the question number.

COLUMN I		COLUMN II	
1.	A sex-linked genetic disorder.	A:	Haemophilia \checkmark
		B:	Colour-blindness \checkmark

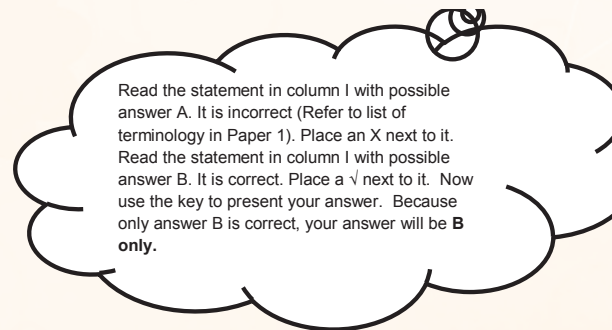



3.1.4 Drawing and interpreting a graph

A) Drawing a graph

Refer to the *MTG Study Guide*, p.107-110, for step-by-step instructions on how to draw the different types of graphs.

- Make sure that you know the difference between a line graph, bar graph, histogram and a pie chart. (Refer to the *MTG Study Guide*, p.107-110).
- Always provide a heading for your graph that includes both independent and dependent variables.
- The independent variable refers to the factor that is being investigated. This factor is usually manipulated/changed by the investigator at the start or during the course of the investigation.
- The independent variable is plotted on the x-axis of a graph.
- The dependent variable refers to the effect of the independent variable. This effect is usually measured in some way and appears on the y-axis of a graph.
- Label the x-axis and y-axis; this could include units of measurement like oc, seconds, years, number of organisms, etc.
- Work out an appropriate scale for the axes.
- When drawing a bar graph, remember that the bars should be of equal width. The spaces between the bars should also be the same.
- When drawing a pie chart, you must use a compass to draw the circle of the chart and a protractor to measure the angles in degrees of the different sectors.

B) Interpreting a graph

- Read the caption of the graph to understand what is represented. The caption gives you the two variables that are under investigation and indicates the relationship between the two variables.
- Remember that the independent variable is on the x-axis and the dependent variable is on the y-axis.
- In a line graph, the shape of the line indicates the relationship between the two variables.

EXAMPLE

(DBE, November 2016, Paper 1)

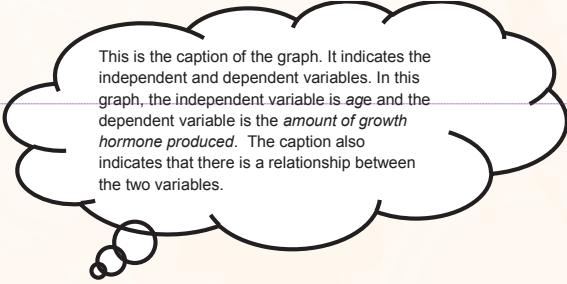

This is the caption of the graph. It indicates the independent and dependent variables. In this graph, the independent variable is *age* and the dependent variable is the *amount of growth hormone produced*. The caption also indicates that there is a relationship between the two variables.

The graph below shows the relationship between the production of growth hormone and age.



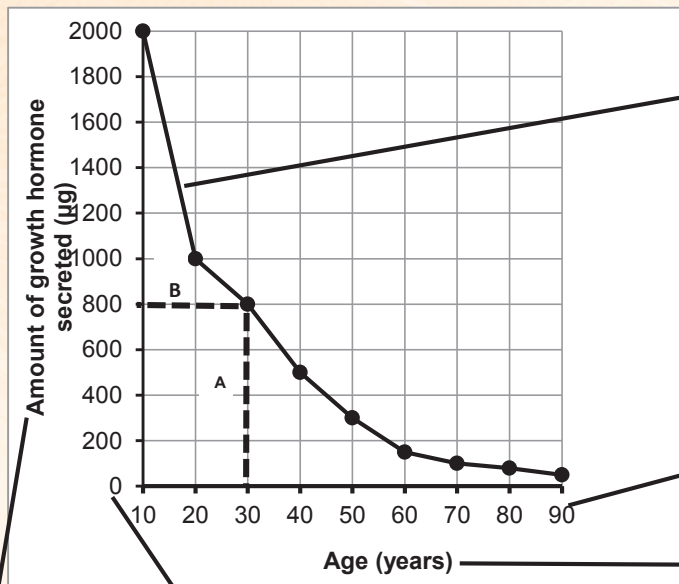

The trend of the graph indicates that: as age increases, the amount of growth hormone secreted decreases.

This is the scale of the x-axis. The intervals are equivalent, i.e. 10 years

The label for this x-axis is age and the unit is years.

The label for this y-axis is amount of growth hormone secreted and the unit is µg

This is the scale of the y-axis. The intervals have the same value - 200 µg.

12

You can be asked to read values from the graph, e.g. how much of the growth hormone is secreted at 30 years?

Take a ruler and pencil and draw a vertical line (A) from the X-axis from point 30 until it touches the graph; then draw a horizontal line (B) from this crossing point to the Y-axis, as indicated by the dotted line. Then read off the value on the Y-axis. In this graph, the answer is 800 µg.

(DBE, November 2014, Paper 2)

- Which species has the smallest cranial capacity?
Answer: Chimpanzee

- Which species has the largest cranial capacity?
Answer: Homo sapiens

(DBE, March 2015, Paper 1)

Refer to the *MTG Study Guide*, p.109-110, for step-by-step instructions on how to draw a pie chart and how to convert percentages into degrees in order to measure the angles of each sector.

- Calculate the total amount of carbon dioxide emitted by China and the USA?
Answer: 23% + 19% = 43%

(Remember: 1 mark is for showing your working, 1 mark is for the final answer and 1 mark is for the unit.)

3.1.5 Interpreting a table

A table is used to organise and present data that were collected using as few words as possible.



A table should have a caption.

It is used as a summary of data.

A table is divided into rows and columns.

Each column and row may have its own heading indicating the unit, if applicable.

Rows run from left to right across the table.

Columns are the vertical blocks of a table.

Tables are used to:

- record the results of an investigation
- illustrate certain patterns/trends
- compare things
- summarise information
- provide the data that will be used to construct a graph

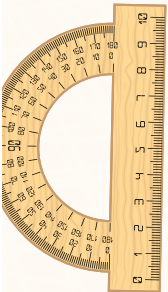

COUNTRY	CARBON DIOXIDE EMISSIONS (%)
China	23
European Union	13
USA	19
India and Russian Federation	12
Other	33

[Adapted from www.environmentalprotectionagency.gov/climatechange]

3.1.6 Diagrams

When answering questions with diagrams:

Read the introductory statement/s for the diagram. It will tell you what the diagram is about.

Study the diagram and write the missing labels on the diagram before looking at the questions that relate to it.

This will help you to focus on the topic. Then read through the questions and answer each question.





EXAMPLE

EXAMPLE

The diagram below shows a phase during meiosis.

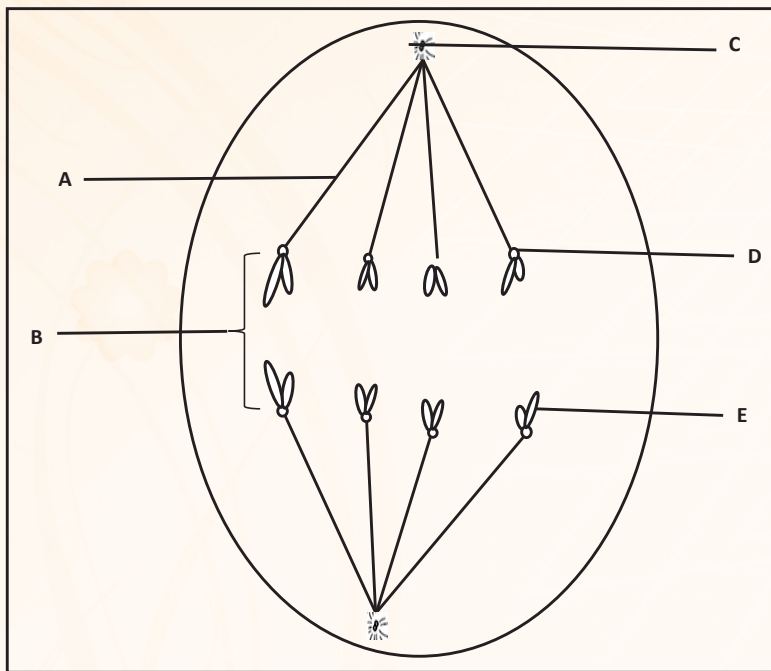
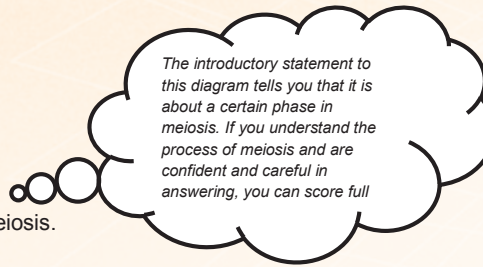

The diagram below shows a phase during meiosis.

- Identify part:
 - A** (Part A is the spindle fibre that holds/pulls the chromatids to the poles of the cell.)
 - B** (Part B is a chromosome, as it consists of 2 chromatids.)
 - C** (Part C is the centriole, which forms when the centrosome divides into two and these move to opposite poles of the cell during cell division.)
 - D** (Part D is the centromere that holds two chromatids together.)
 - E** (Part E is the chromatid – two chromatids and a centromere make up a chromosome.)
- Name the phase illustrated in the diagram above.

(The phase illustrated in the diagram is Anaphase II, because it is chromatids and NOT chromosomes that are moving apart. If it was chromosomes that were moving apart, the phase would have been Anaphase I.)

- How many chromosomes were present in the phase before the one shown in the diagram above?

(4 chromosomes were present, because the phase before Anaphase II is called Metaphase II. Whole chromosomes would be present at the equator of the cell during Metaphase II.)
- How many chromosomes would be found in each gamete at the end of this division?

(4 chromosomes would be found in each gamete, because the halving of chromosomes already occurred during Meiosis I. The parent cell must have had 8 chromosomes before meiosis started.)



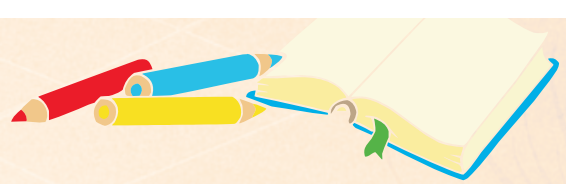
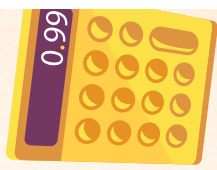

5. Explain why the diagram above is NOT representative of a cell from a human being.

(This cell only shows 4 chromosomes, i.e. 8 chromatids. A human cell in the same phase would have 23 chromosomes, i.e. 46 chromatids.)

6. State ONE place where meiosis takes place in the human male.

(Testes: Meiosis occurs when gametes are produced in the human reproductive organs. Sperm cells are produced in the testes of males. Ova are produced in the ovaries of females.)

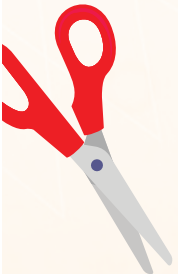
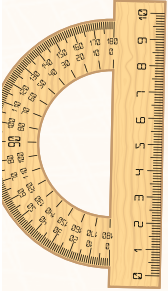



3.1.7 Calculations:

You will be expected to do simple calculations that involve addition, subtraction, multiplication and division.

You must have a calculator.

Show your step-by-step working calculations, because marks are allocated for the steps as well as for the correct answer.

Include the unit in your final answer.

The following examples will guide you in calculating averages and percentages.

A) How to calculate averages:

$$\begin{aligned}
 \text{Average pulse rate} &= \frac{\text{sum of the pulse rate of all participants}}{\text{total number of participants}} \\
 &= \frac{(76 + 91 + 95 + 89 + 89)}{5} \\
 &= \frac{440}{5} \\
 &= 88 \text{ BPM}
 \end{aligned}$$

Remember to show your step-by-step working calculation, because marks are allocated for the steps as well as for the correct answer.

Remember to include the unit in your final answer.



Find the sum of all the items and divide this total by the number of items.

EXAMPLE:

The table below represents the results of an investigation that was carried out to determine the effect of caffeine on the pulse rate of different people after 10 minutes of drinking a cup of black coffee.

NUMBER OF PARTICIPANTS	PULSE RATE (BPM)
1	76
2	91
3	95
4	89
5	89

B) Calculating percentage:

Take the value that you want to determine the percentage of, and divide it by the sum of all the items.

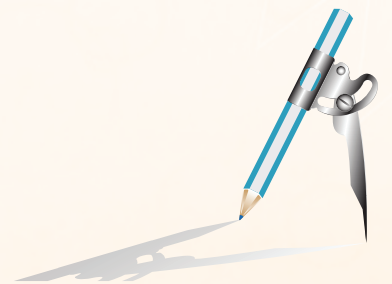

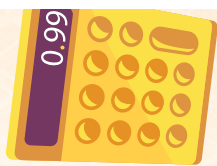

EXAMPLE:

The table below shows the number of plant species found at different altitudes in a mountain range.

ALTITUDE (m)	NUMBER OF PLANT SPECIES
1000	65
1500	60
2000	35
2500	20
Total	190

Calculate the percentage of plant species found at an altitude of 1500m.

$$= \frac{60}{190} \times \frac{100}{1}$$

$$= 31.58\% \text{ BPM}$$

3.1.8 Essay writing

The essay in Section C in the final examination is allocated 20 marks. The 20 marks are divided into 17 marks for content and 3 marks for synthesis. Answering this question requires planning. Let us look at the planning steps using the following essay question, which appeared in the *Life Sciences Paper 2, June 2016* exam paper, as an example.

Describe the location, structure and functions of the DNA molecule and the process whereby copies of this molecule are made.

Content: 17
 Synthesis: 3
 Total: 20

STEP 1: Read the essay question thoroughly to determine the topics that are being covered. Underline the key words in the essay question that provide clues to the different topics.

Describe the location, structure and functions of the DNA molecule and the process whereby copies of this molecule are made.

The topic is: DNA the code of life, with sub-topics DNA location, structure and function and DNA replication.

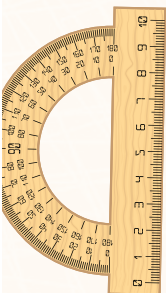



STEP 2: Interpret and analyse the essay question. Identify the aspects or processes that are required from each of the topics identified. You may need to read the question more than once to enable you to do this.

Location: refers to where DNA is found in a cell.

Structure of DNA: refers to components that make up DNA, the shape of the DNA molecule, etc.

Functions: refer to the role of DNA in protein synthesis and inheritance.

DNA replication: the process by which DNA makes a copy of itself.



STEP 3: Write the first draft of your essay in a logical and organised manner, linking each aspect that is discussed. This will help you obtain a high mark from the 3 marks allocated for the synthesis of your essay.

Your plan or draft of the essay may take the form of a flow diagram. **But the final answer to the essay CANNOT be in the form of a flow diagram.**

Write your essay using the following headings:

1. Location of DNA
2. Structure of DNA
3. Functions of DNA
4. DNA replication

STEP 4: Write out the final version of your essay. Draw a line through the plan/draft of your essay, so that the marker assesses your final answer and not your plan/draft.

The structure of your final version should look like the following:

Location, structure and function

- DNA is located in the nucleus/chromosomal/genes
- and mitochondria
- DNA is a nucleic acid
- It has a double stranded
- helix configuration
- consisting of building blocks called nucleotides
- The three components of a nucleotide are:
 - Nitrogenous bases
 - Phosphate portion
 - Deoxyribose sugar portion (in DNA)
- 4 nitrogenous bases of DNA:
 - adenine (A) bonds with thymine (T)

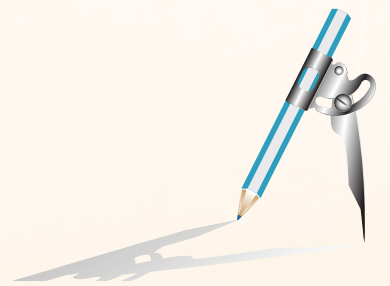

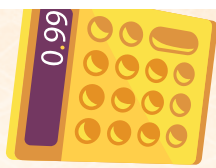

- cytosine (C) bonds with guanine (G)
- by hydrogen bonds
- Sections of DNA carry hereditary information.
- DNA contains coded information for protein synthesis.

Replication

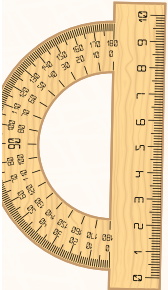

- The double helix unwinds
- Double stranded DNA unzips
- as the weak hydrogen bonds break
- Each original DNA strand serves as a template
- Free nucleotides build
- a new DNA strand onto each of the original DNA strands
- by attaching to their complementary nitrogenous bases (A to T, and C to G), this results in two identical DNA molecule

Content: 17

STEP 5: Now read the question again to check if your answer answers the question.

SYNTHESIS MARK: 3 marks are allocated for the presentation of the essay. Remember that the synthesis is made up of three parts, i.e. relevance, logical sequence and a comprehensive answer. The criteria used to allocate marks to each part are shown below.

Criterion	Relevance (R)	Logical sequence (L)	Comprehensive (C)
Generally	All information provided is relevant to the topic.	Ideas are arranged in a logical/ cause-effect sequence.	All aspects required to be addressed by the essay have been sufficiently addressed.
In this essay question	Only information relevant to location, structure, and functions of the DNA molecule and the replication process is discussed.	Only information relevant to the location, structure and functions of the DNA molecule and the replication process is discussed in a logical and sequential manner.	At least 8 correct points are given for the location, structure and functions of the DNA molecule; and 5 correct points are given for the explanation of the replication process.
Mark	1	1	1

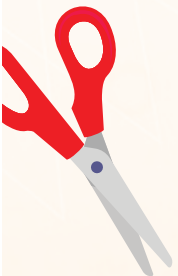

4 REVISION QUESTIONS SET 1 (MASTER 40%)

4.1 INTRODUCTION

In Life Sciences, 40% of EACH paper (60 marks) is allocated to questions set on remembering and recalling content that you have studied. The content you need to study to achieve at least 60 marks can be found in the *Life Sciences MTG Study Guide*.

These 60 marks are spread across the questions in each paper. These remembering questions are mainly addressed in section A and in some questions in sections B and C. In section B, these remembering questions are normally the first few questions. Do not get worried if you cannot answer every question. Identify all the remembering questions in the entire paper first and answer them, before attempting the more difficult questions.

In this section, we will give examples of these remembering questions per topic for each paper. Tips will be provided on how to approach answering these questions.

4.2 LIFE SCIENCES PAPER 1 TOPICS AND QUESTIONS

Study the section on meiosis in the *MTG Study Guide* (p.9 – 16) before you answer the following questions. With question one, the answers are provided, together with explanations.

Meiosis				
It is a type of cell division where a diploid cell undergoes two cell divisions to form four haploid cells (gametes)	Before meiosis begins DNA replication takes place. This results in each chromosome consisting of two chromatids joined by a centromere	First division: One diploid cell gives rise to two haploid cells	Second division: The two haploid cells divide further to form four haploid cells or gametes	Biological importance: Crossing over introduces genetic variation. It ensures that sex cells have a haploid number of chromosomes

(DBE, March 2016, Paper 2)

Q1. The diagrams below show different phases in meiosis.

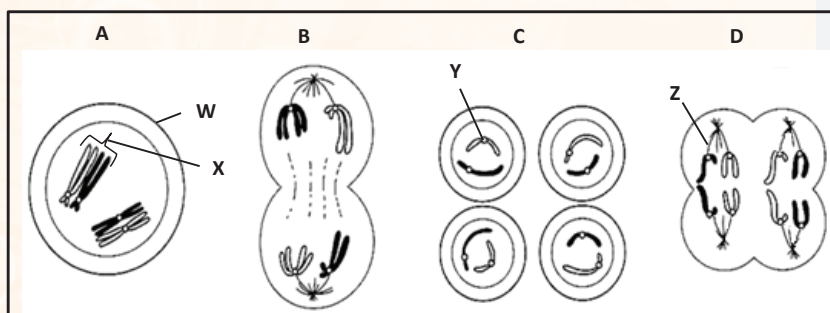

1.1 Label structures **W** and **X**.

(2)

(W – Cell membrane /Plasmalemma. The outer membrane is the cell membrane and the inner membrane is the nuclear membrane. The outer line is not a cell wall. X - Homologous chromosomes/Bivalent. The chromosome pair is similar in length and shape.)



- 1.2 How many chromosomes are present in each cell in:
- (a) Phase A (4 - there are 2 homologous pairs of chromosomes, which equals 4 chromosomes.) (1)
- (b) Phase C (2 – this is the end of the reduction division - Telophase II. Each of the 4 daughter cells/ gametes contain half of the original number of chromosomes.) (1)
- 1.3 Give only the LETTER of the diagram that represents Anaphase II. (D – chromatids are being pulled apart - not chromosomes, as in Anaphase I). (1)
- 1.4 State the function of structure Y and structure Z. (Y – It holds the 2 chromatids of a single chromosome together, because it is the centromere. Z – It pulls chromosomes/chromatids to the poles, because it is the spindle fibre.) (2)
- 1.5 Identify phase C. (Telophase II, because four daughter cells are formed with only half the original number of chromosomes.) (1)

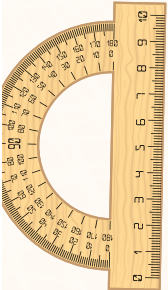

(8)

(DBE, March 2015, Paper 1)

Q2 Study the diagram below, which shows a process that occurs in a human male.

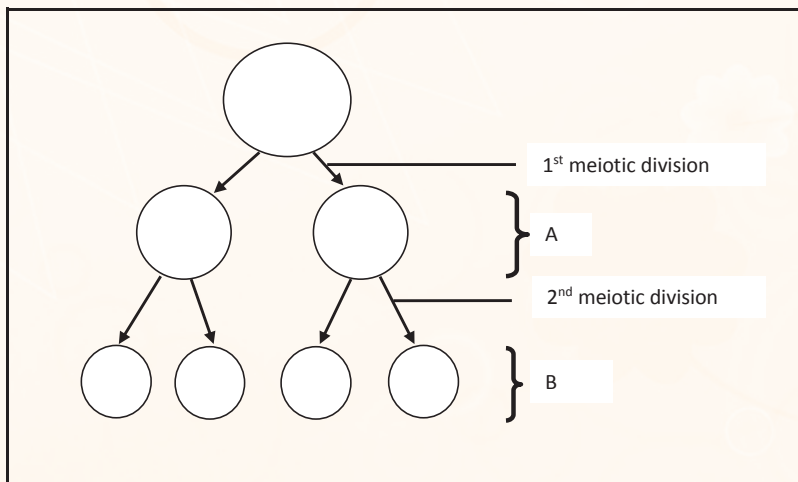

- 2.1 Name the process by which male gametes in humans are formed through meiosis. (1)
- 2.2 Name the organ in males in which the process mentioned in QUESTION 2.1 takes place. (1)





2.3 How many chromosomes will be found in each cell at:

(a) A (1)

(b) B (1)

2.4 Name TWO processes occurring during the 1st meiotic division that contribute to the genetic variation of cells in **A**. (2)

2.5 How many cells at **B** will carry the Y-chromosome? (1)

2.6 What are the mature cells at **B** called? (1)

(8)



(DBE, November 2015, Paper 1)

Q3 The diagram below illustrates a phase in meiosis.

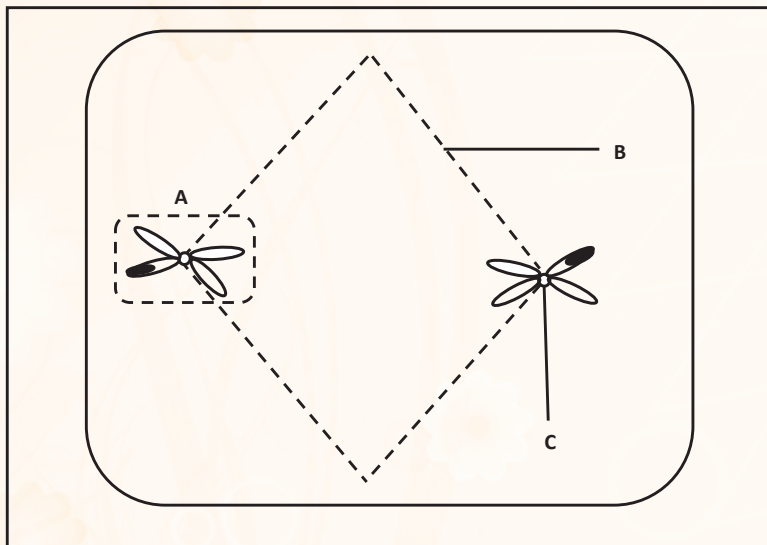

3.1 Identify part:

(a) **A** (1)

(b) **B** (1)

(c) **C** (1)

3.2 IDENTIFY THE PHASE ILLUSTRATED ABOVE. (1)

3.3 GIVE A REASON FOR YOUR ANSWER TO QUESTION 3.2. (2)

(6)



(DBE, June 2015, Paper 2)



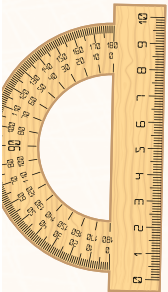
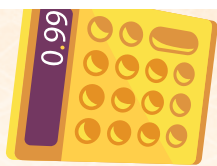

Q4 The diagram below shows cells of an organism in one of the phases of meiosis.

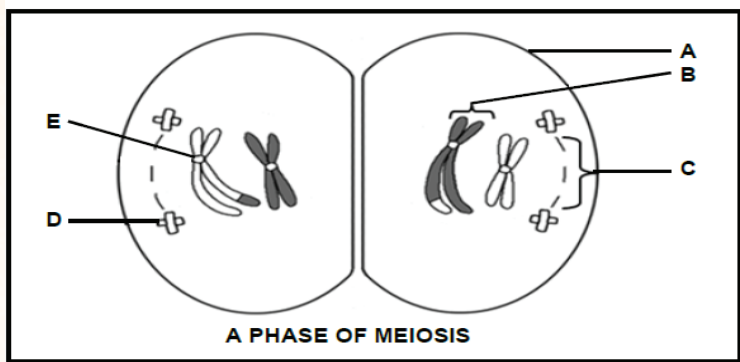

- 4.1 Which phase of meiosis is represented in the diagram? (1)
- 4.2 Give the LETTER and NAME of the part that:
- (a) is responsible for the formation of spindle fibres (2)
 - (b) carries the genetic information (2)
 - (c) holds the chromatids together. (2)
- 4.3 State the number of chromosomes that would be present in each of the cells of this organism:
- (a) at the beginning of meiosis (1)
 - (b) in a gamete of this organism. (1)
- (9)**

Reproduction in Vertebrates

Study the section on reproduction in vertebrates in the *MTG Study Guide* (p.17 and 18) before you answer the following questions. You need to know the meaning of the following reproductive strategies:

- External and internal fertilization
- Ovipary, vivipary and ovovivipary
- Amniotic egg
- Precocial and altricial development
- Parental care

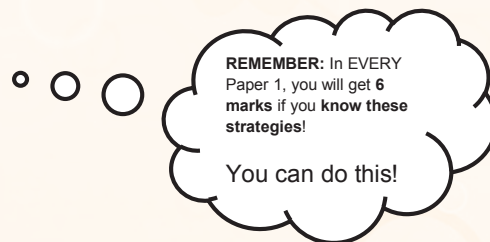

(DBE, November 2015 (2), Paper 1)





Q1 Read the passage below.

REPRODUCTIVE STRATEGY IN KANGAROOS

The red kangaroo reproduces by sexual reproduction. After mating, the fertilised egg undergoes gestation in the uterus. After 33 days of gestation, the red kangaroo gives birth to an offspring that is hairless, blind and only a few centimetres long.

The offspring moves from the vagina by following a trail of saliva secreted by the mother to a protective pouch where it remains for a year. During this time, the offspring drinks milk from the mother, who has teats in her pouch.

After 190 days, it leaves the pouch.



[Adapted from www.livescience.com]



1.1 State whether:

(A) FERTILISATION IN THE RED KANGAROO SPECIES IS INTERNAL OR EXTERNAL (1)

*(INTERNAL FERTILISATION BECAUSE FERTILISATION TAKES PLACE **INSIDE** THE FEMALE'S BODY)*

(b) The red kangaroo species is OVIPAROUS, OVOVIVIPAROUS or VIVIPAROUS (1)

(Viviparous - because the foetus is attached to the mother by an umbilical cord and the young are born live and not hatched from an egg.)

1.2 Give a reason for your answer to QUESTION 1.1(b). (1)

(The foetus develops in the mother's uterus.)

1.3 State TWO ways in which the survival of the offspring immediately after birth is ensured in the red kangaroo species. (2)

(- Protected as it develops in the mother's pouch - Nourished with mother's milk)} parental care

These answers are taken directly from the extract.

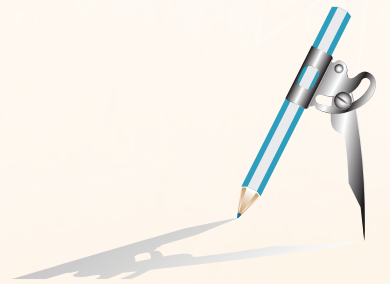

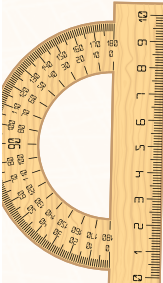
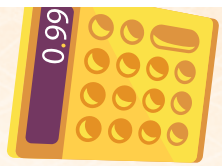

Human reproduction

<p>Female reproduction system:</p> <p>Diagram of female reproduction system with labels, functions and parts.</p> <p>Diagram of the ovum</p>	<p>Male reproduction system:</p> <p>Diagram of male reproduction system with labels, functions and parts.</p> <p>Diagram of sperm cell</p>	<p>Puberty:</p> <p>period where physical changes occur in the bodies of males and females in order for males and females to be capable of sexual reproduction. Testosterone stimulates puberty in males. Oestrogen stimulates puberty in females</p>	<p>Menstrual cycle:</p> <p>Events occurring in the ovary (ovarian cycle) and uterus (uterine cycle) during the menstrual cycle of approximately 28 days</p>	<p>Hormonal control of the menstrual cycle:</p> <p>Role of the 4 hormones in controlling the menstrual cycle i.e. FSH, LH, oestrogen and progesterone</p>	<p>Development of the foetus:</p> <p>Development of the embryo after fertilisation to form a foetus. Development of the foetus for 39-40 weeks. Diagram of the foetus inside the uterus</p>
---	---	---	--	--	--

Study the section on human reproduction in the *MTG Study Guide* (p.19 – 26) before you answer the following questions. With question one, the answers are provided, together with explanations.

Refer to the *MTG Study guide* (p. 120-123) for the blank diagrams on human reproduction. You can use them to practise your drawing skills. If you can label all these diagrams correctly on your own you will be well prepared for the exam.

(DBE, November 2014, Paper 1)

Q1 Study the diagrams below that show the male and female reproductive systems.

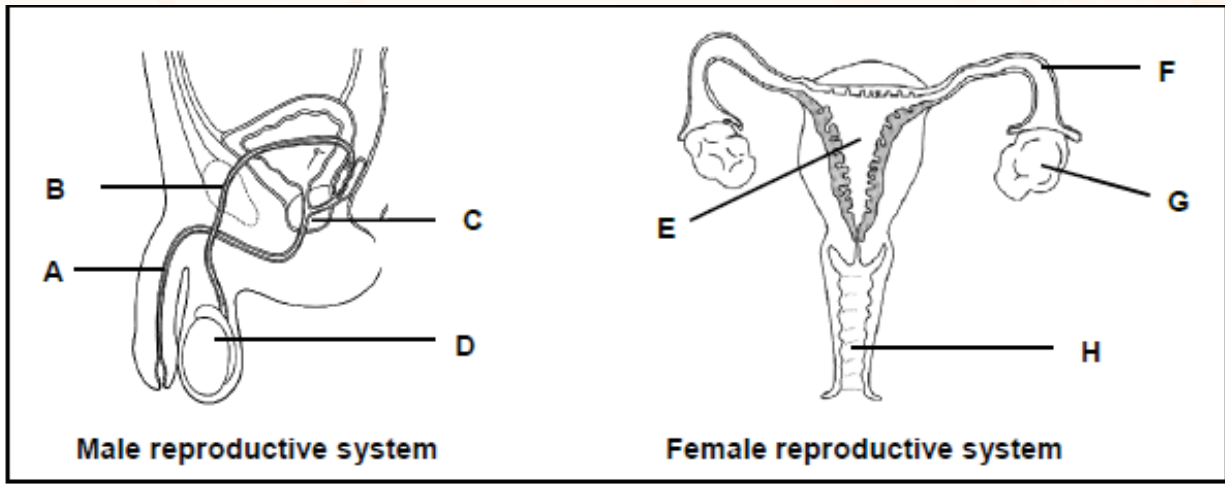



1.1 Identify parts **A**, **B** and **F**.

(3)

(A - Urethra - it is the common duct that transports both urine and semen.

B - Vas deferens/sperm duct – the duct transporting only sperm from the testes.

F - Fallopian tube- it is the tube that connects the ovary to the uterus; it allows for the passage of ova and it is where fertilisation takes place.)

1.2 State ONE function of each of the following:

(a) The fluid produced by part **C**.

(1)

(Part C is the prostate gland that secretes an alkaline fluid with the following functions:

- Protects the sperm cell against the acidic environment of the vagina.

- Increases the motility of the sperm.

- Provides nutrients.)

Any 1

(b) Part E

(1)

(Part E is the uterus. The functions are:

- The place for foetus to develop during pregnancy.

- It is muscular, in order to push out the baby during childbirth.

- It protects the foetus/prevents infection (mucus plug formed by the cervix.)

Any 1

1.3 Give the LETTER ONLY of the organ where meiosis takes place in the:

(a) Male reproductive system.

(1)

(D - meiosis occurs in the testis to form haploid sperm (23 chromosomes).)

(b) Female reproductive system.

(1)

(G- meiosis occurs in the ovary to form haploid ova with 23 chromosomes.)

1.4 Name the type of gametogenesis that takes place in the:

(a) Male reproductive system.

(1)

(Spermatogenesis - development of sperm cells.)

(b) Female reproductive system.

(1)

(Oogenesis - development of ova.)

1.5 State TWO functions of part H.

(2)

(Part H is the vagina. The functions are as follows:

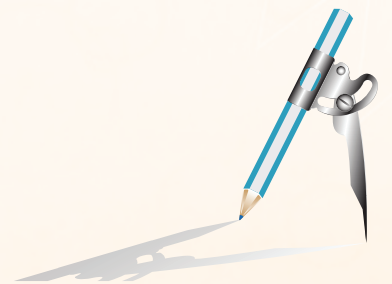

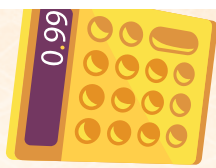

- Serves as a birth canal.
- Allows for the passage of blood / endometrial lining/amniotic fluid / placenta.
- Facilitates sexual intercourse / receives semen

Any 2

1.6 Explain why it is necessary for part **D** to be 'outside' the body in males. (2)

(Part D is the testis.

- To keep the testes at a temperature (2-3°C) that is lower than body temperature

(37°C) / optimum temperature for sperm production.

- which is necessary for the production of healthy sperm / so that healthy sperms can survive.)

(13)

(DBE, June 2016, Paper 1)

Q2 The diagram below represents a sperm cell.

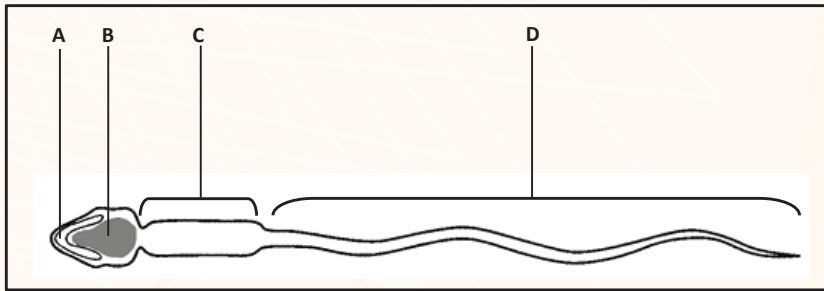

2.1 Identify part:

(a) B (1)

(b) D (1)

2.2 Explain ONE way in which the sperm cell is adapted to ensure effective movement towards the fallopian tubes. (2)

2.3 Explain the consequences for reproduction if a sperm cell did not have part **A**. (3)

(7)

(DBE, November 2016, Paper 1)

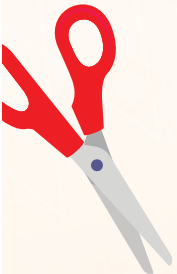

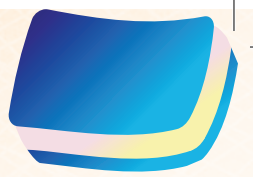
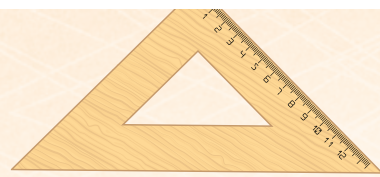

Q3 The schematic diagram below shows a human ovum that is about to be fertilised. The diagram is not drawn to scale.

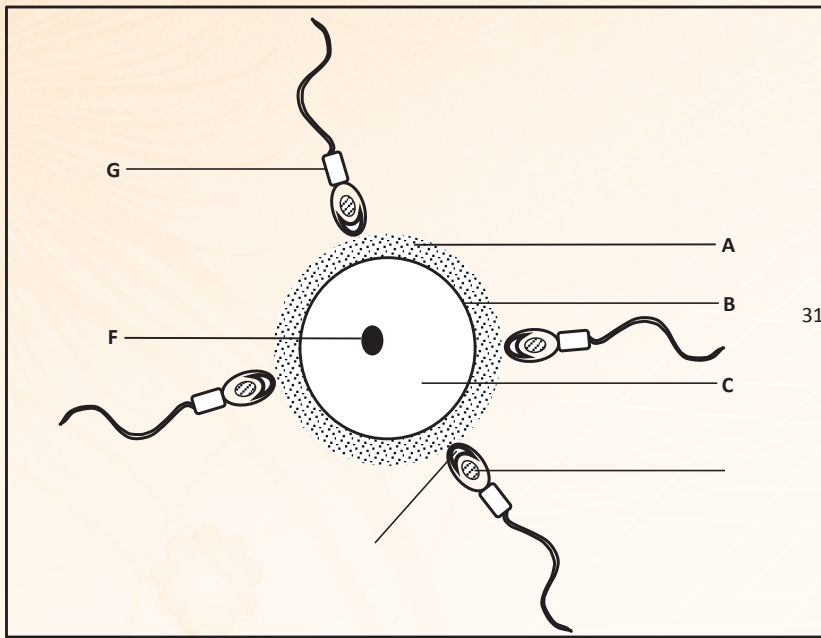

3.1 Identify part:

- (a) A (1)
- (b) B (1)
- (c) C (1)
- (d) F (1)

3.2 Give the LETTER and NAME of the part that:

- (a) contains the mitochondria (2)
- (b) contains enzymes required to penetrate the ovum (2)
- (c) will enter the ovum during fertilisation. (2)

(10)



Responding to the environment (humans)

<p>Neurons: Neurons are specialised cells which connect the brain and the spinal cord to all other parts of the body. Functions of 3 types of neurons i.e. motor, sensory and interneurons</p>	<p>The brain: Structure and functions of the parts of the brain: (i) Cerebrum (ii) Cerebellum (iii) Medulla oblongata (iv) Hypothalamus (v) Corpus callosum</p>	<p>The spinal cord: Structure of the spinal cord. Describe reflex action using a diagram</p>	<p>Human eye: Structure and functions of parts of the eye. <i>Accommodation</i> is the adjustment of the shape of the lens to see objects clearly whether they are far away or close to the eye. <i>Pupillary mechanism</i> regulates the amount of light entering the eye by adjusting the size of the pupil. Visual defects</p>	<p>Human ear: Structure and functioning of parts of the human ear. Process of hearing. Balance. Hearing defects</p>
---	--	---	--	--

Study the section on responding to the environment (humans) in the *MTG Study Guide* (p.41 – 52) before you answer the following questions. With question one, the answers are provided, together with explanations.

ns.

Refer to the *MTG Study guide* (p. 124-129) for the blank diagrams on human reproduction. You can use them to practise your drawing skills. If you can label all these diagrams correctly on your own, you will be well prepared for the exam.

(DBE, June 2015, Paper 1)

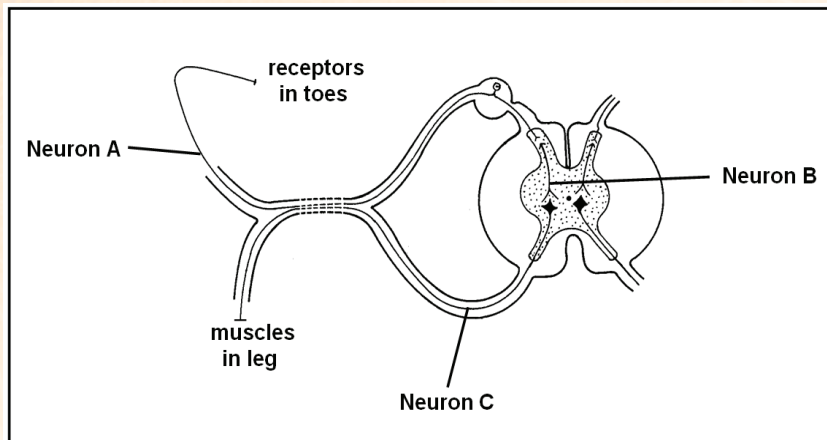

Q1 Study the diagram below of a section through a human spinal cord and the neurons involved in a reflex arc.

1.1 Define a *reflex action*. (2)

(A rapid, automatic response to a stimulus.)

Note: you need to learn the definitions by heart.

1.2 Identify neurons **A**, **B** and **C**. (3)

(A – Sensory neuron/Afferent neuron – it is the neuron that is attached to the receptor - in this case the toes.)

B – Interneuron/connector neuron/association neuron/relay neuron. This neuron connects the sensory neuron (A) to the motor neuron (C) and it is always found inside the spinal cord /brain.

C – MOTOR NEURON/EFFERENT NEURON. THIS NEURON IS CONNECTED TO THE EFFECTOR – IN THIS CASE, THE MUSCLES IN THE LEGS.)

1.3 WRITE DOWN ONLY THE LETTER OF THE NEURON (A OR C) THAT IS PROBABLY DAMAGED IF A PERSON:

(a) can feel the stimulus but cannot respond; (1)

(C – if you can feel the stimulus, the sensory neuron is still working; if you can't respond to the stimulus, then the motor neuron is not working)





(b) is able to walk, but cannot detect any stimulus.

(1)

(A – if you can walk, the motor neuron is not damaged; if you can't detect the stimulus, then the sensory neuron is not working)

1.4 State the significance of the reflex action in humans.

(1)

(It protects the human body against further damage, -because it is a very rapid, automatic response – you don't think about it.)

Note: learn the first part of the answer off-by-heart, i.e. It protects the human body against further damage.

Try the following 4 questions on your own. Write down your answers first before you refer to the answers provided in Section 5.

Carefully study the diagrams!

(DBE, November 2015, Paper 1)

Q2 The diagram below shows the central nervous system in a human.

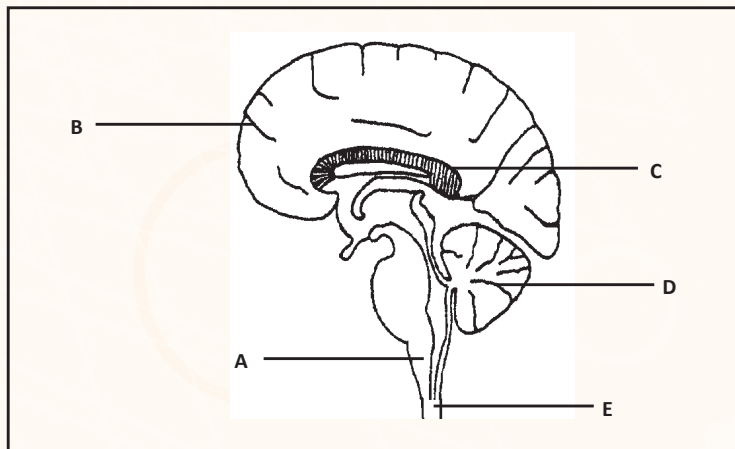

2.1 Identify part:

(a) A

(1)

(b) C

(1)

(c) D

(1)

2.2 State THREE functions of part B.

(3)

(6)





(DBE, June 2015, Paper 1)

Q3 Study the diagram below of a longitudinal section through the human eye.

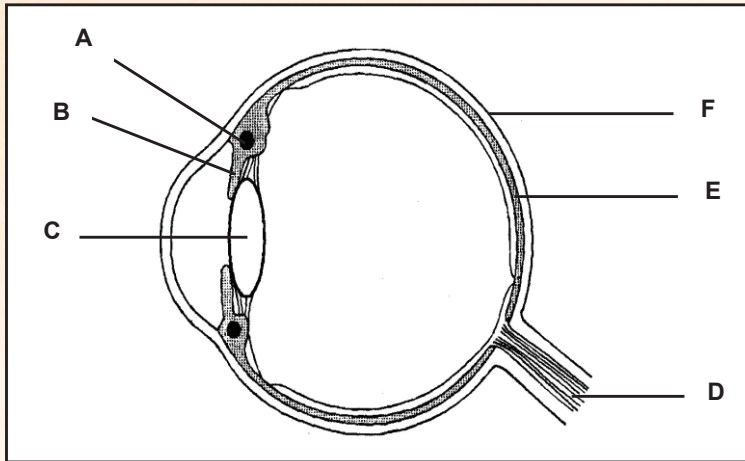

3.1 Label parts **A**, **B** and **E**. (3)

3.2 Give the LETTER only of the part that:

- (a) protects the delicate internal structures; (1)
 - (b) transmits impulses to the cerebrum; (1)
 - (c) becomes cloudy or opaque as a person gets older, leading to decreased vision; (1)
 - (d) contracts or relaxes when the distance of an object from the eye changes. (1)
- (7)



(DBE, November 2015 (2), Paper 1)

Q4 The diagram below shows a human ear.

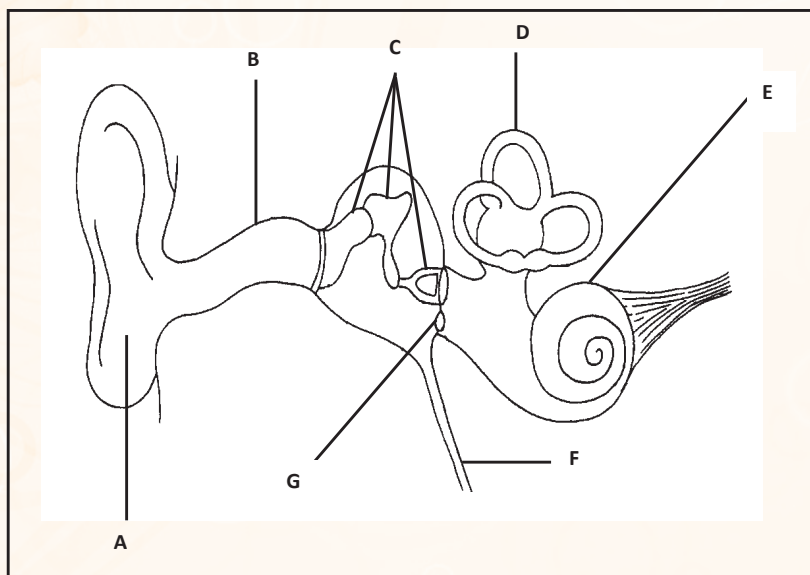

4.1 Identify parts **A** and **D**. (2)

4.2 Write down the LETTER only of the part that:

- (a) conducts sound waves towards the middle ear; (1)





- (b) absorbs pressure from the inner ear; (1)
 - (c) ensures equal pressure on either side of the tympanic membrane; (1)
 - (d) transmits vibrations to the inner ear; (1)
 - (e) contains the organ of Corti. (1)
- (7)

(DBE, November 2016, Paper 1)

Q5 The diagram below shows a neuron in a human.

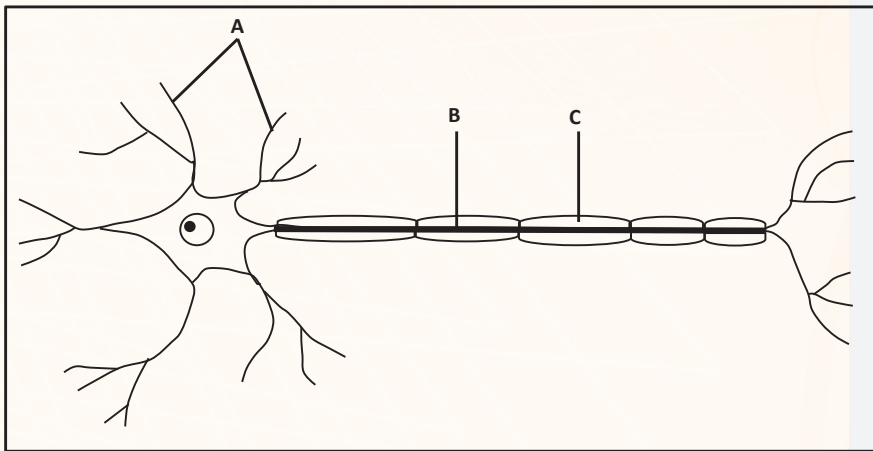

- 5.1 Identify the type of neuron represented in the diagram. (1)
 - 5.2 State ONE function of part B. (1)
- (2)

Human endocrine system and homeostasis in humans

<p>Endocrine system consists of glands that produce different hormones.</p> <p>Functions of the hormones produced by the following glands:</p> <ul style="list-style-type: none"> (i) Hypothalamus - secretes hormone ADH (ii) Pituitary gland (hypophysis) - secretes hormones GH, TSH, FSH, LH and prolactin (iii) Thyroid gland - secretes thyroxine <p>Pancreas - secretes glucagon and insulin</p> <p>Testes - secretes testosterone</p> <p>Ovary - secretes oestrogen and progesterone</p> <p>Adrenal gland - secretes adrenalin</p>	<p>Negative feedback to regulate levels of hormones in the blood.</p> <p>Example - feedback mechanism between TSH and thyroxine</p>	<p>Homeostasis:</p> <p>Is the process of maintaining a constant, internal environment within narrow limits, despite changes that take place internally and externally.</p> <p>Negative feedback mechanisms controlling the concentration of:</p> <ul style="list-style-type: none"> (i) glucose (ii) CO₂ (iii) water (iv) salts <p>Thermoregulation:</p> <p>Role of sweating, vasodilation and vasoconstriction in regulating body temperature to be $\pm 37^{\circ}\text{C}$.</p>
--	--	---





Refer to the *MTG Study Guide* (p.130 and 131) for blank diagrams on the human endocrine system and homeostasis in humans. You can use them to practise your drawing skills. If you can label all these diagrams correctly on your own, you will be well prepared for the exam.



Study the section on the human endocrine system and homeostasis in humans in the *MTG Study Guide* (p.53 – 61) before you answer the following questions. With question one below, the answers are provided, together with explanations.

(DBE, June 2016, Paper 1)

Q1 The diagram below shows parts of the endocrine system in humans.

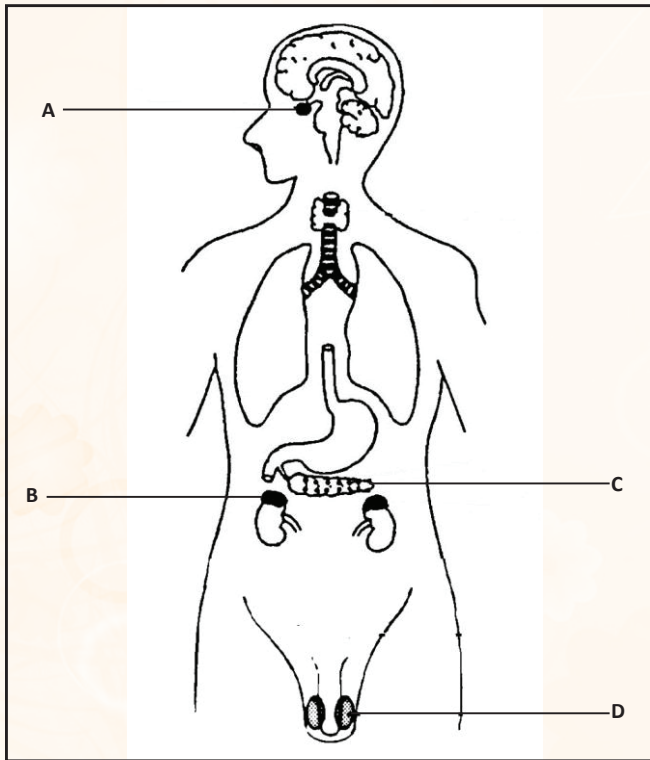

1.1 Identify gland:

(a) **A**

(1)

(*Hypophysis/ Pituitary gland. Study the diagram on p.53 of the MTG Study Guide*)

(b) **B**

(1)

(*Adrenal gland – the gland on top of the kidney.*)

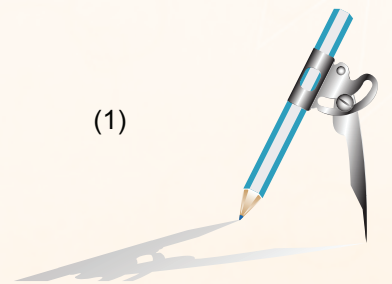



1.2 Give the LETTER and the NAME of the gland that secretes a hormone responsible for:

- (a) starting puberty in males (2)

(D – Testis. These produce testosterone, which is responsible for the development of secondary sexual male characteristics.)

- (b) stimulating absorption of glucose by cells (2)

(C – Pancreas/Islets of Langerhans. It produces insulin, which stimulates cells to absorb glucose.)

- (c) making the kidney tubules permeable to water (2)

(A – Hypophysis/Pituitary gland. It produces ADH, which increases the permeability of the renal tubules, so that more water can be re-absorbed into the bloodstream.)

(8)

Try the following 2 questions on your own. Write down your answers first before you refer to the answers provided in Section 5.

Study the general sequence of events in a negative feedback mechanism (p.54 of the *MTG Study Guide*). When you read a flow diagram on negative feedback mechanisms, start with the NORMAL levels of the hormone/gas/salt.

(DBE, March 2015, Paper 1)





Q2 Study the flow diagram below of a homeostatic mechanism used to regulate the concentration of salts in the human body.

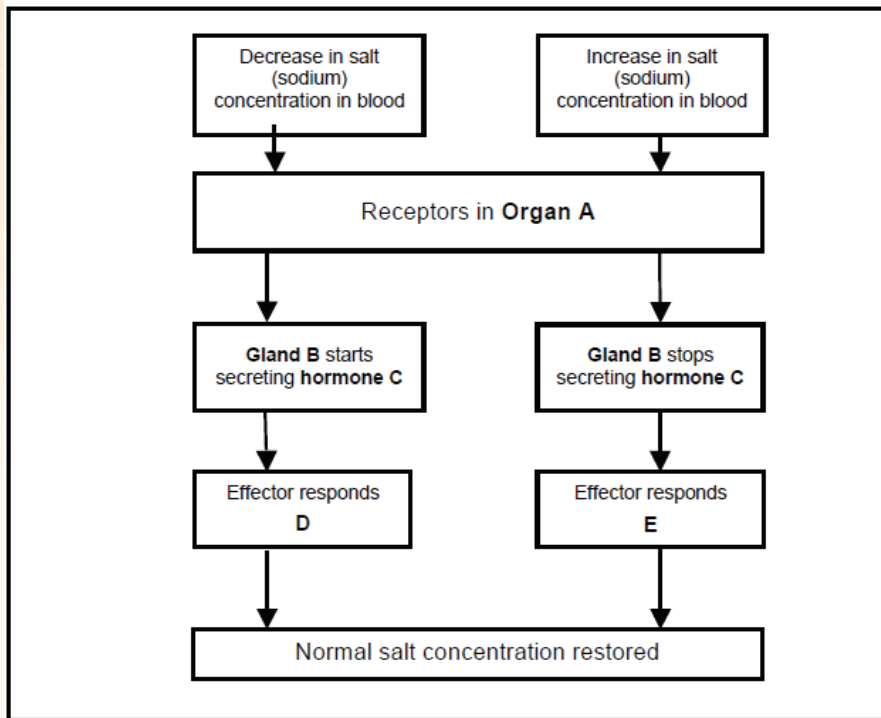

2.1 Define *homeostasis*. (2)

2.2 Give the name of the following:

- (a) organ **A** (1)
- (b) gland **B** (1)
- (c) hormone **C** (1)

2.3 Describe the response by the effector at **D**. (2)

(7)

(DBE, November 2015(2), Paper 1)

Q3 Describe the negative feedback mechanism that occurs when the thyroxin level decreases below normal. (5)

Responding to the environment - plants		
Functions of the following plant hormones: (i) Auxins (ii) Gibberellins (iii) Abscisic acid	Role of auxins in geotropism and phototropism	Role of the following as plant defence mechanisms: (i) Chemicals (ii) Thorns

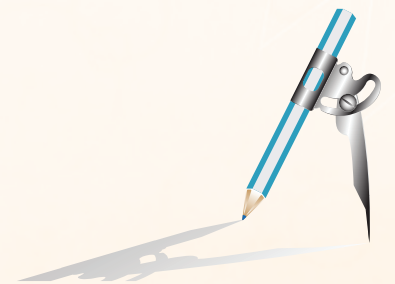

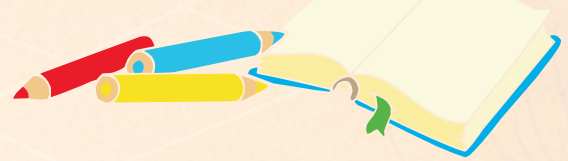
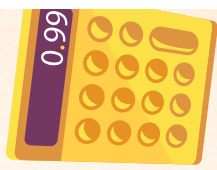

Study the section on responding to the environment (plants) in the *MTG Study Guide* (p.62 – 64) before you answer the following questions. With question one, the answers are provided, together with explanations.

It is very important that you understand the role of auxins in phototropism and geotropism. Remember that: in plant stems/shoots, a high concentration of auxins stimulates cell division and growth; BUT in roots, a high concentration of auxins inhibits cell division and growth.

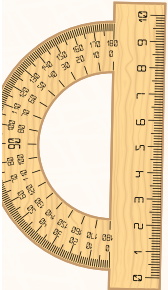

(DBE, November 2015, Paper 1)

Q1 The diagram below shows the growth movement of a part of a plant towards a stimulus.

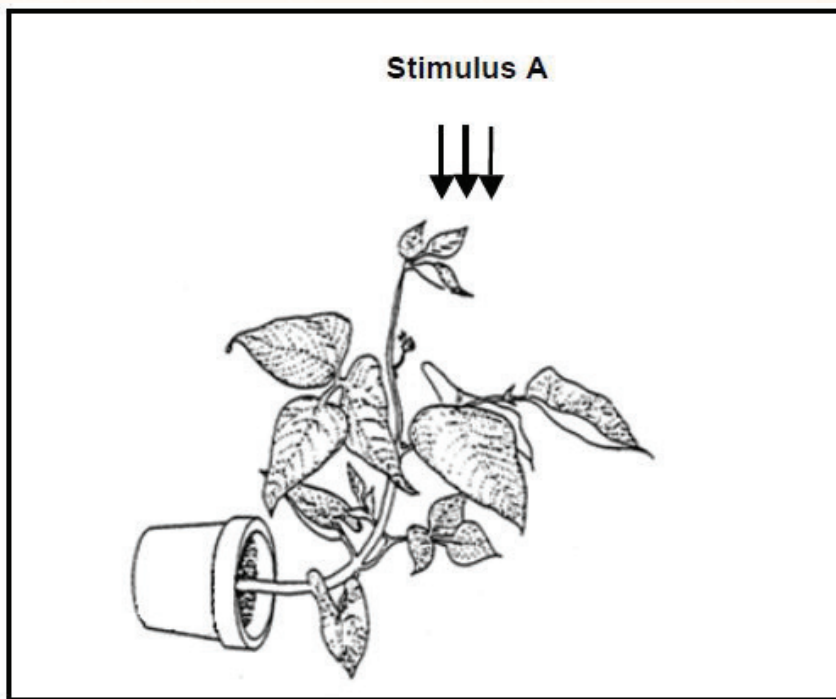

1.1 What growth movement is represented in the diagram?

(1)

(Phototropism – the plant stem is growing towards the stimulus, which is light.)





1.2 Identify the stimulus labelled A. (1)

(Light/sunlight/radiant energy – the plant stem is growing towards the stimulus, which is light.)

1.3 Name the growth hormone that is responsible for the growth movement named in QUESTION 1.1. (1)

(Auxins – it stimulates cell division and growth in stems.)

1.4 Will a high concentration of the growth hormone named in QUESTION 1.3 stimulate or inhibit growth in the roots? (1)

(Inhibit - in plant stems/shoots a high concentration of auxins stimulates cell division and growth, BUT in roots, a high concentration of auxins inhibits cell division and growth.)

1.5 Name the phenomenon whereby the buds at the tip of the plant regulate the growth of the lateral branches. (1)

(Apical dominance)

(5)

(DBE, June 2015, Paper 1)

Q2 Explain the growth response of a plant when the stem is exposed to light coming from one side only. (4)

Responding to the environment - plants		
Functions of the following plant hormones: (i) Auxins (ii) Gibberellins (iii) Abscisic acid	Role of auxins in geotropism and phototropism	Role of the following as plant defence mechanisms: (i) Chemicals (ii) Thorns

Study the section on human impact on the environment in the *MTG Study Guide* (p.83 – 104) before you answer the following questions. With question one, the answers are provided, together with explanations.

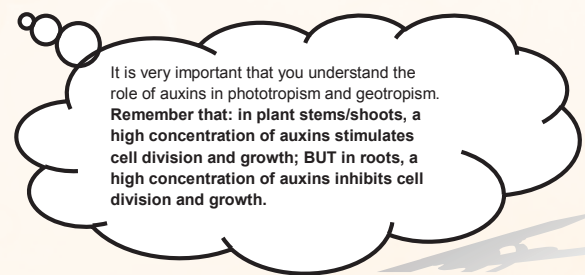

(DBE, June 2015, Paper 1)

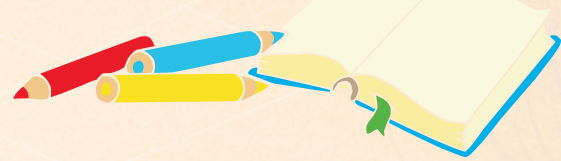
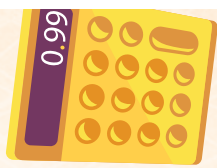

Q1 Energy in South Africa is mainly generated by coal power stations. The pie chart below shows energy consumption in different sectors of a South African city in 2007.

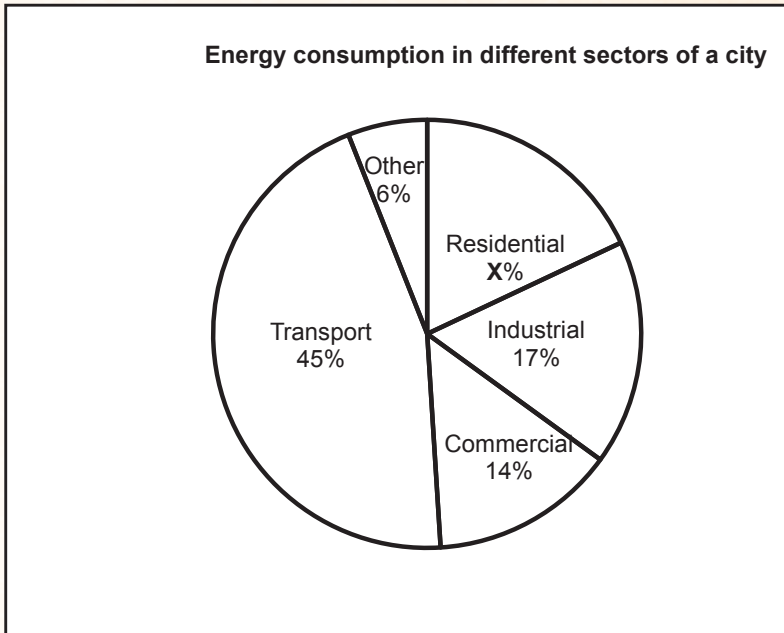

[Adapted from *Energy Scenarios for CT to 2050*, 2011]

1.1 Determine the value of X. Show ALL calculations. (2)

(100 – (17+14+45+6): Add all the known values together and deduct from 100% = 18%. Remember to include the unit in your answer, i.e. %.)

1.2 Which sector consumes the most energy in this city? (1)

(Transport – it has the highest value - 45%.)

1.3 Residential energy consumption in this city increased by 3% in 2009.

Give TWO possible reasons for this increase. (2)

(You must give two possible reasons why more energy was used by the residential sector. Your answer can be any two of the following:

- Increase in the number of houses built/increase in population.
- More houses received electricity connectivity.
- More street lamps were provided by the municipality.
- A very cold winter.)

1.4 Explain the impact of the increased use of energy generated from coal power stations on climate change. (4)

(The question you have to answer is: If more coal is used to produce energy, what impact will it have on climate change?)

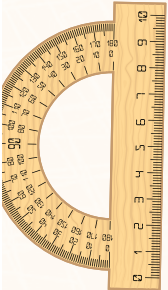



- It creates more CO_2 , which is released into the atmosphere.
- CO_2 traps more heat in the atmosphere.
- This causes the 'enhanced greenhouse effect'.
- This, in turn, causes a rise in the average global temperature.
- This is known as 'global warming'.

1.5 South Africa, like many other countries, has signed a declaration to reduce its

CO_2 output over time. Explain TWO strategies that could be implemented by the South African government to achieve this reduction in CO_2 output. (4)

(In this answer, you must state the strategy and ALSO explain how this strategy will reduce CO_2 emissions. Use ANY TWO of the following:

- Invest in alternative forms of fuel/energy generation, e.g. solar/wind/nuclear, that will limit dependence on fossil fuels.
- Improve the public transport system to reduce the number of cars on the roads.
- Invest in research and development of new technologies to decrease CO_2 output.
- Introduce legislation to penalise offending industries/to provide incentives to industries that adhere to legislation to reduce CO_2 emissions.
- Educate people on strategies to reduce CO_2 output.

(13)

(DBE, November 2015, Paper 1)



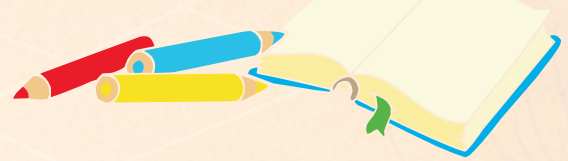
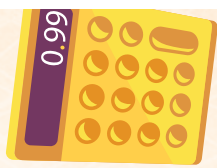

Q2 Read the extract below.

FOOD SECURITY IN SOUTH AFRICA

One of the challenges in South Africa is access to food by the poor. In 2009, Statistics SA conducted a survey to determine the percentage of households in each province that had access to food.

The results are shown in the table below:

PROVINCE	HOUSEHOLDS THAT HAVE ACCESS TO FOOD (%)
Western Cape	85
Eastern Cape	79
Mpumalanga	79
Free State	67
Northern Cape	75
North West	79
KwaZulu-Natal	77
Limpopo	88
Gauteng	82

South Africa seems to have adequate food access in urban areas, but the same cannot be said of households in rural areas. In rural areas, the price of staple foods (e.g. maize and rice) is usually higher than in urban areas.

Increasing agricultural activity is the key to food security and poverty alleviation. The majority of people living in rural areas have access to land, but more needs to be done to make household farming (growing crops for family use only) in these areas more efficient.

[Adapted from *Food Security*, Department of Agriculture, Forestry and Fisheries, March 2011]

- 2.1 What is meant by *food security*? (2)
 - 2.2 Suggest ONE reason why food prices in rural areas are usually higher than food prices in urban areas. (1)
 - 2.3 State TWO ways in which household farming could reduce poverty. (2)
 - 2.4 Suggest TWO ways in which the Department of Agriculture can improve farming in rural areas. (2)
- (7)





4.3 Life Sciences Paper 2 topics and questions

DNA: Code of life			
<p>DNA and RNA: Structure, location and functions of DNA and RNA</p> <p>DNA forms genes which carry hereditary information.</p> <p>DNA contains coded information for protein synthesis</p> <p>RNA plays a role in protein synthesis</p>	<p>DNA replication and its significance: DNA makes copies of itself so that it can be shared between the resulting daughter cells during cell division</p>	<p>DNA profiles: Uses and interpretation of DNA profiles</p> <p>Each person has a unique DNA profile</p> <p>A profile is represented as an arrangement of black bars representing DNA fragments of a person</p>	<p>Protein synthesis: Process by which proteins are made in each cell of an organism to form enzymes, hormones and new structures for cells</p> <p>Process is divided into :</p> <p>(i) <i>transcription</i> where DNA forms mRNA. mRNA now has the coded message for protein synthesis</p> <p>(i) <i>translation</i> where tRNA reads the code on mRNA and amino acids links to form a protein</p>



(DBE, November 2016 Paper 2)

Q.1 The diagram below shows a part of a DNA molecule.

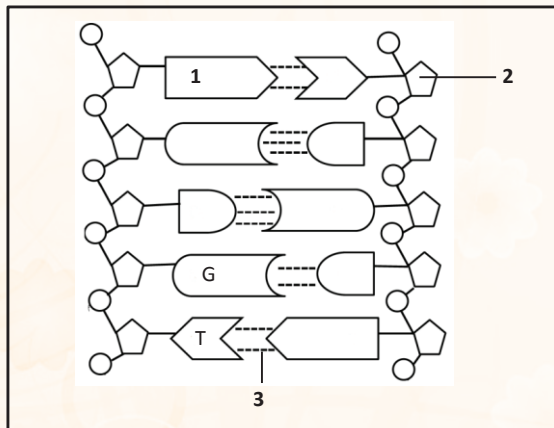

1.1 Provide labels for:

(a) 1 (1)

(Adenine – it matches the shape of the complementary T in the diagram.)

Remember: Adenine pairs with Thymine.

(b) 2 (1)

(Deoxyribose sugar. This is because the molecule represented is DNA. The sugar portion of DNA is deoxyribose; the sugar portion of RNA is ribose.)

(c) 3 (1)

(Hydrogen bond. This is a weak bond found between nitrogenous bases A and T and C and G in DNA.)

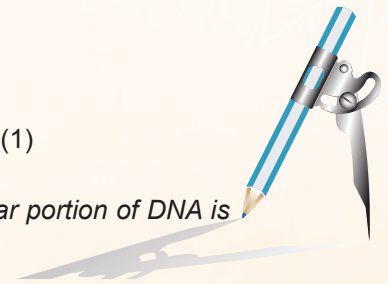



1.2 Give the number of nucleotides shown in the diagram. (1)

(10 – a nucleotide is made up of 3 components, i.e. a sugar, phosphate and a nitrogenous base. The molecule depicted has 10 nucleotides.)

1.3 Give ONE difference between the nitrogenous bases found in DNA molecules and those found in RNA molecules. (2)

(DNA has the nitrogenous base thymine whereas RNA has the nitrogenous base uracil. Remember the question asked for differences between nitrogenous bases and not any other structural or functional difference. For differences between DNA and RNA please refer to p.2 of the MTG Study Guide.)

(6)

(DBE, March 2015, Paper 2)

Q.2 The diagram below represents DNA replication.

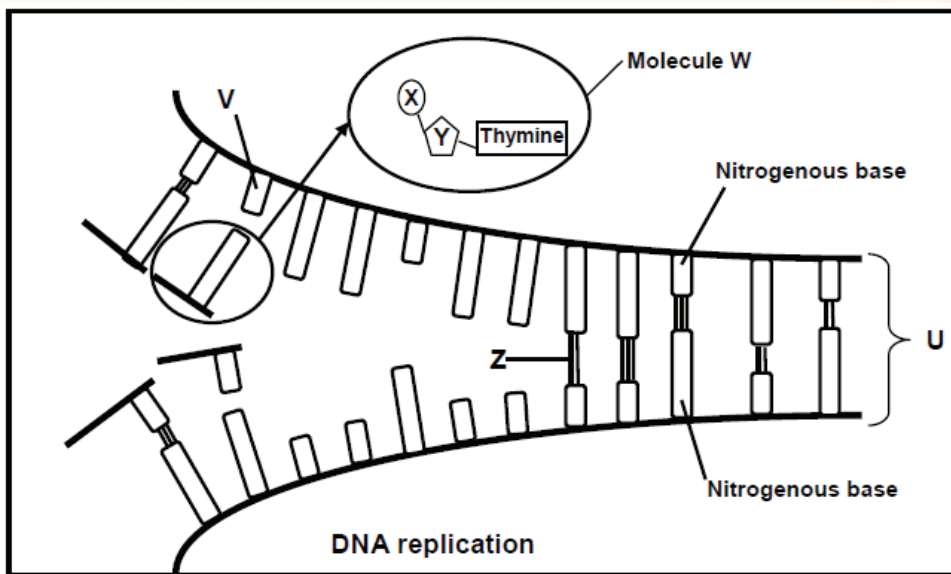

2.1 Identify the following:

- (a) molecules **W** and **U** (2)
- (b) the parts of molecule **W** that are labelled **X** and **Y** (2)
- (c) bond **Z** (1)
- (d) nitrogenous base **V** (1)

2.2 Where in the cell does this process take place? (1)

2.3 Name the phase of the cell cycle in which replication takes place. (1)

(8)

(DBE, March 2016, Paper 2)



Q.3 The diagram below represents two stages of protein synthesis.

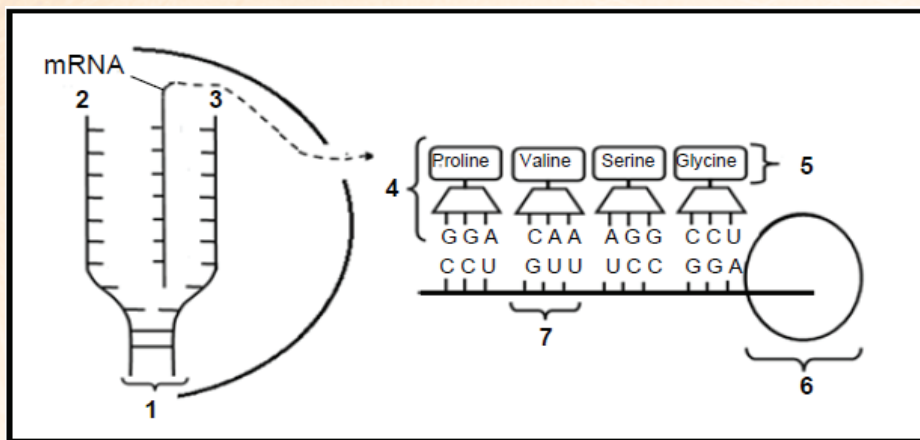

3.1 Provide labels for:

- (a) Molecule 1 (1)

(DNA. The molecule is found in the nucleus. It is forming mRNA and it is double-stranded.)

- (b) Organelle 6 (1)

(Ribosome. It is the organelle that is the site of protein synthesis in the cytoplasm.)

3.2 Give only the NUMBER of the part that represents a:

- (a) DNA template strand (1)

(2 – this is the strand on which a mRNA strand is formed.)

- (b) Monomer of proteins (1)

(5 – Proteins are made up of amino acids e.g. Proline, Valine, etc.)

- (c) Codon (1)

(7 – a triplet of bases found on the mRNA strand.)

3.3 Describe *translation* as it occurs at organelle 6. (4)

- The mRNA attaches to the ribosome
- When each codon of the mRNA
- matches with the anticodon on the tRNA
- the tRNA brings the required amino acid to the ribosome
- When the different amino acids are brought in sequence
- adjacent amino acids are linked by peptide bonds
- to form the required protein/polypeptide

(Translation is a process in which tRNA molecules read the code on the mRNA and bring amino acids together in a particular sequence so as to form a required protein.)



3.4 Provide the:

- (a) DNA sequence that codes for glycine (2)

(CCT – The mRNA codon for glycine is GGA. When working backwards from this, you will get to the DNA triplet, which is CCT.)

- (b) Codon for proline (2)

(CCU – This can be read directly from the mRNA strand, as the triplets on mRNA are called codons. Remember the triplets on tRNA are called anticodons.)

3.5 State TWO differences between a DNA nucleotide and an RNA nucleotide. (4)

(DNA has deoxyribose sugar and RNA has ribose sugar. DNA has nitrogenous base thymine and RNA has nitrogenous base uracil, instead of thymine.)

(17)

(DBE, November 2014, Paper 2)

Q.4 Study the diagram below, which shows a part of the protein synthesis process.

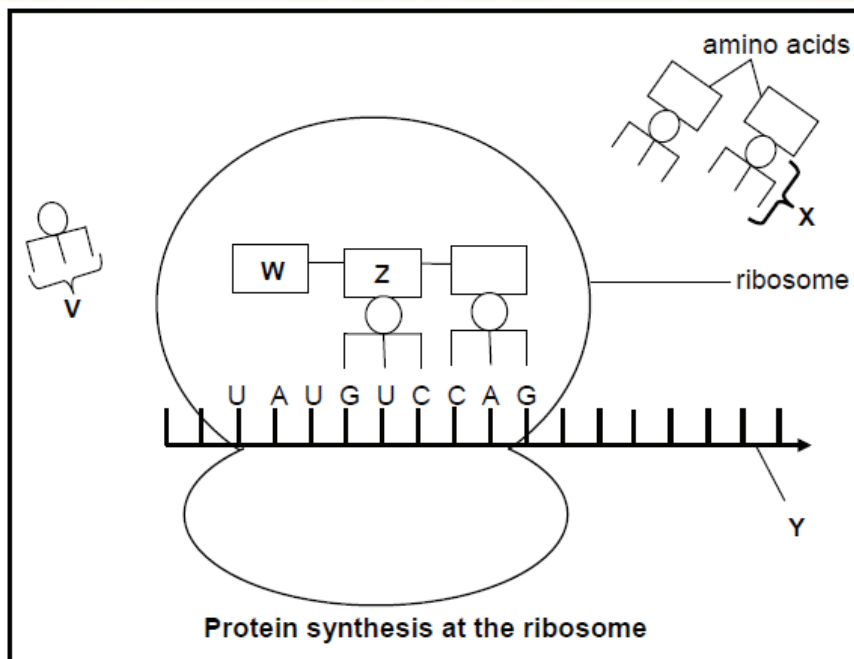

4.1 Identify the stage of protein synthesis that is shown in the diagram above. (1)

4.2 Identify molecules X and Y. (2)

4.3 State the term for the group of three nitrogenous bases indicated by V. (1)

4.4 Give the nitrogenous bases on the DNA strand that code for the bases UAU on molecule Y. (1)

4.5 Use the table below to identify amino acid W.





tRNA	Amino acid
GUC	glutamine
UAA	isoleucine
AUA	tyrosine
CCC	glycine
GGG	proline
CAG	valine

(2)

4.6 Name and describe the process that occurs in the nucleus to produce molecule Y. (5)

(12)



32%



Mathematics



Physics

Accounting

Meiosis

Refer to the questions in Paper 1.

Genetics and inheritance

Concepts in inheritance: Understanding the relevant concepts in genetics e.g genotypes, phenotypes, homozygous, heterozygous etc.	Monohybrid cross: Doing genetic problems involving one characteristic with 2 alleles using a template format	Sex - linked inheritance: Doing genetic problems involving two sex -linked disorders i.e. haemophilia and colour blindness	Pedigree diagrams/ family tree are used to study the inheritance of characteristics in a family over a number of generations	Genetic engineering: (i) Stem cell research (ii) Genetically modified organisms (iii) Cloning	Paternity testing: The use of blood grouping and DNA profiles for paternity testing
---	--	--	--	---	---

Study the section on genetics in the *MTG Study Guide* (p.27 – 40) before you answer the following questions.

Use the following genetic problem format or template to solve all monohybrid genetic problems. Remember that by following this format you would already have earned 2 marks, namely for stating P_1 and F_1 and meiosis and fertilisation. Please write down the format when you answer any genetic cross question in the examination.

✓	P ₁	Phenotype	× ✓	OR	<table border="1"> <tr> <th colspan="2">Gametes</th> </tr> <tr> <td> </td> <td> </td> </tr> <tr> <td> </td> <td> </td> </tr> </table>	Gametes					
		Gametes									
		Genotype	× ✓								
✓	Meiosis	Gametes	× ✓	1 mark for correct gametes							
		Fertilisation			1 mark for correct genotypes						
	F ₁	Genotype	✓								
		Phenotype	✓								

Q1 In dogs, rough hair (**H**) is dominant over smooth hair (**h**). A heterozygous rough-haired dog is mated with a smooth-haired dog. Provide a representation of a genetic cross to show the phenotypic ratio of the puppies.

Remember the following when solving the above genetic problem:

- Please note that the problem above is an example of a **COMPLETE DOMINANCE** genetic cross.
- The allele for rough hair is dominant (**H**).
- The allele for smooth hair is recessive (**h**).
- The heterozygous rough-haired dog has to be **Hh**.
- The smooth-haired dog can only be smooth-haired if it is homozygous recessive, i.e. **hh**.
- **The general rule is that any recessive characteristic can only show up in the phenotype if it is homozygous recessive.**
- You can now solve the problem as shown below.

P₁ Phenotype Rough hair x Smooth hair ✓
 Genotype Hh x hh ✓

Meiosis

G/gametes H h x h h ✓

Fertilisation

F₁ Genotype Hh Hh hh hh ✓

 Phenotypic ratio 1 rough hair : 1 smooth hair ✓

P₁ and F₁ ✓
Meiosis and fertilisation ✓ Any 6

OR

P₁ Phenotype Rough hair x Smooth hair ✓
 Genotype Hh x hh ✓

Meiosis

Fertilisation

Gametes	H	h
h	Hh	hh
h	Hh	hh

1 mark for correct gametes
 1 mark for correct genotypes

F₁ Phenotypic ratio 1 rough hair : 1 smooth hair ✓

P₁ and F₁ ✓
Meiosis and fertilisation ✓ Any 6 (6)

(DBE, November 2016, Paper 2)

Q.2 You have two rose plants, both with pink flowers. You cross them and find that most of the offspring are pink; however some are red and some are white.

Use a genetic cross to show how breeding two pink flowering plants can result in pink, red and white flowering plants. Use the letter **R** for the red allele and **W** for the white allele.

(6)

Remember the following when solving the above genetic problem:

- The problem above is an example of an **INCOMPLETE DOMINANCE** genetic cross.
- The allele for red flowering plants is co-dominant (**R**) with the allele for white flowering plants (**W**).
- **The general rule in incomplete dominance is that capital letters are used for the alleles because no one allele is dominant over the other, resulting in an intermediate colour (pink) showing in the phenotype of the offspring.**
- In the above problem, the genotype of the red flowering plants would be **RR** and that of the white flowering plants **WW**.
- The genotype of the pink flowering plants would be **RW**.
- You can now solve the problem as shown below.

(DBE, November 2009, Paper 1)



Q.3 Fur colour in mice is controlled by a gene with two alleles. Black fur colour (B) is dominant over brown fur colour (b).

Use a genetic cross to show the possible genotypes and phenotypes of the off-spring, if a mouse that is heterozygous for fur colour is crossed with a mouse with brown fur.

(6)

(DBE, November 2016, Paper 2)

Q.4 Human blood groups are controlled by multiple alleles.

4.1 Name ALL the alleles that control human blood groups. (3)

4.2 How many of the alleles named in QUESTION 4.1 can an individual inherit? (1)

4.3 Give a reason for your answer to QUESTION 4.2. (2)

4.4 A man has blood group **A** and his wife has blood group **B**. Their first child has blood group **AB** and the second child has blood group **O**. What can one conclude about the blood groups of their future children?

(3)

(9)

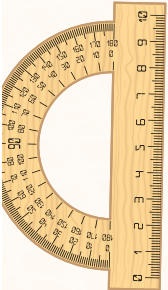

Evolution

<p>Evidence for evolution Role of the following as evidence for evolution:</p> <ul style="list-style-type: none"> (i) fossil record (ii) biogeography (iii) modification by descent (iv) genetics 	<p>Sources of variation The following contributes to variation:</p> <ul style="list-style-type: none"> (i) Meiosis - crossing over and random arrangement of chromosomes (ii) Mutations (iii) Random fertilisation (iv) Random mating 	<p>Theories of Lamarck and Darwin Lamarck's laws:</p> <ul style="list-style-type: none"> (i) inheritance of acquired characteristics (ii) 'Law' of use and disuse <p>Darwin's theory of natural selection</p>	<p>Punctuated equilibrium explains the speed at which evolution takes place</p>	<p>Artificial selection: Humans select the characteristic that they want in animals and plants to have</p>	<p>Speciation: Formation of new species from pre-existing species</p>	<p>Human evolution:</p> <ul style="list-style-type: none"> (i) Similarities between humans and African apes (ii) Differences between humans and African apes (iii) Phylogenetic trees to show the place of the family Hominidae in the animal kingdom (iv) 'Out of Africa' hypothesis
--	--	--	--	---	--	--

(DBE, June 2015, Paper 2)



Q.1 Diagram 1 shows variation in a species of fish living in a lake. There was a rocky island that extended across the whole length of the lake, but it was under water due to the high-water level. The fish were therefore able to move freely throughout the lake.

Diagram 2 shows the same lake many years later. A drought had caused the level of the water in the lake to drop so that the rocky island in the centre separates the lake into two smaller lakes, **A** and **B**, for a long period of time.

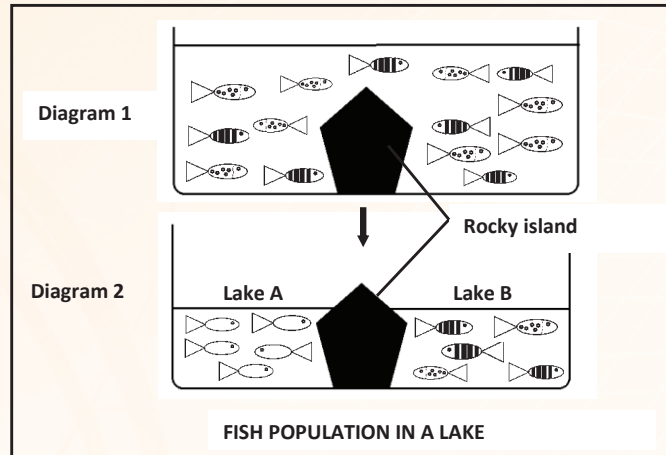

1.1 DEFINE POPULATION. (2)

1.2 STATE FOUR POSSIBLE CAUSES OF THE VARIATION IN THE FISH POPULATION IN DIAGRAM 1. (4)

1.3 EVENTUALLY, AS SHOWN IN DIAGRAM 2, LAKE A AND LAKE B CONTAINED TWO DIFFERENT SPECIES OF FISH.

(A) NAME THE PROCESS THAT RESULTED IN THE FISH POPULATION BECOMING TWO DIFFERENT SPECIES. (1)

(B) EXPLAIN HOW THE NEW SPECIES WAS FORMED. (6)

(13)

(DBE, November 2015, Paper 2)

Q.2 The characteristics of organisms can be changed through selective breeding and the genetic engineering process.

2.1 STATE TWO SIMILARITIES OF THE SELECTIVE BREEDING PROCESS AND THE GENETIC ENGINEERING PROCESS. (2)

2.2 Explain TWO reasons why some people may be against the use of genetic engineering. (4)

(6)





Study the section on human evolution in the MTG Study Guide (p.72 – 81) before you answer the questions below. In particular, study the similarities and differences between human and African apes on p.72 -73. You can score easy marks if you learn these similarities and differences well.

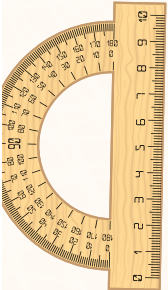

(DBE, June 2015, Paper 2)

Q.3 The diagram below shows possible relationships between members of the family *Hominidae*.

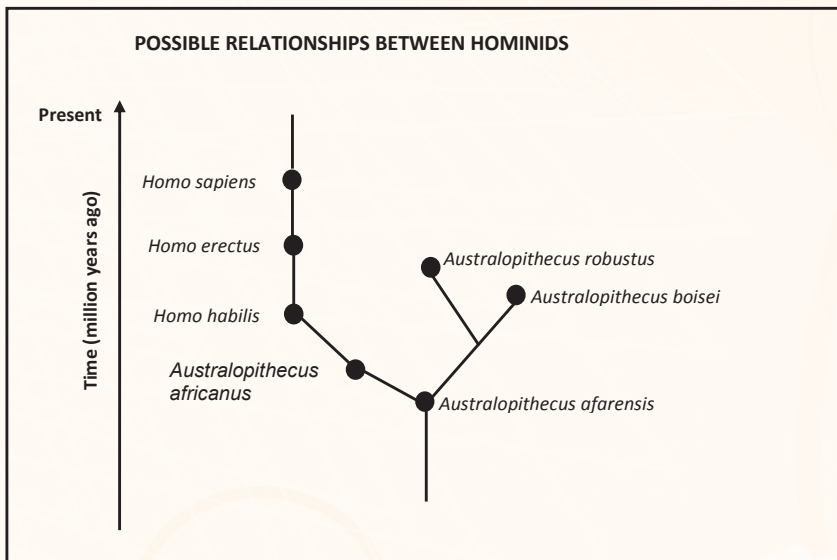

[Adapted from <http://www.ideacentre.org>]

- 3.1 What is the name given to the type of diagram above? (1)
- 3.2 How many of each of the following are represented in the diagram?
- (a) Genera (1)
- (b) Species (1)
- 3.3 Explain why *A. robustus* and *A. boisei* are more closely related than *A. boisei* and *A. afarensis*. (2)
- 3.4 Which of the hominids in the diagram above is considered to have been the first to use tools? (1)
- 3.5 Name TWO *Australopithecus* fossils found in South Africa. (2)
- 3.6 Explain how the location and the age of *Homo* fossils are used as evidence for the 'Out of Africa' hypothesis. (3)
- (11)**





(DBE, June 2015, Paper 2)

Q.4 The diagrams below represent parts of the skeletons of an African ape and a human. Diagrams **A** and **B** are drawn to scale.

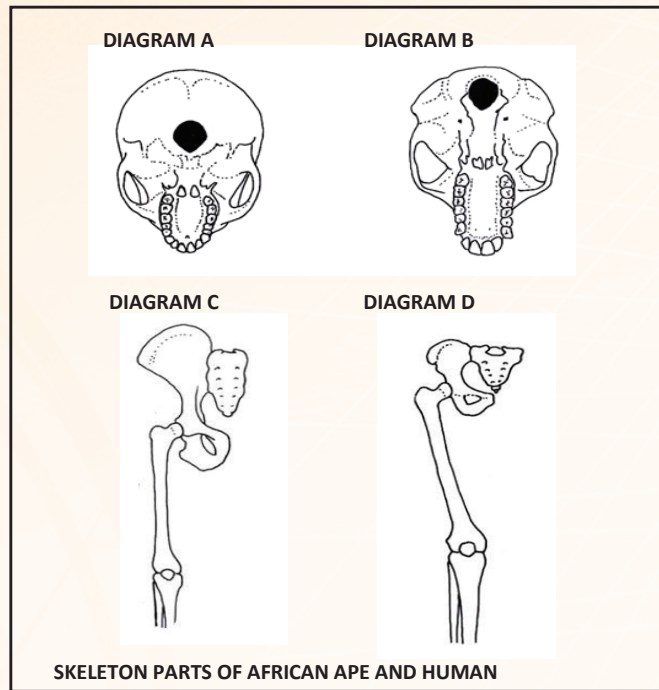

- 4.1 WRITE DOWN THE LETTERS ONLY OF THE DIAGRAMS (A–D) THAT REPRESENT BIPEDAL ORGANISMS. (2)
 - 4.2 EXPLAIN HOW THE SHAPE OF THE PELVIS CONTRIBUTES TO BIPEDALISM. (2)
 - 4.3 EXPLAIN THE SIGNIFICANCE OF THE POSITION OF THE FORAMEN MAGNUM IN THE SKULLS IN DIAGRAM A AND IN DIAGRAM B. (4)
 - 4.4 TABULATE THREE VISIBLE DIFFERENCES BETWEEN THE JAWS/TEETH OF THE SKULLS LABELLED A AND B THAT INDICATE TRENDS IN HUMAN EVOLUTION. (7)
 - 4.5 State THREE physical characteristics of the forelimb/upper limb that humans share with African apes. (3)
- (18)**

(DBE, March 2016, Paper 2)



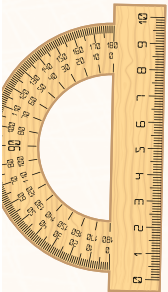
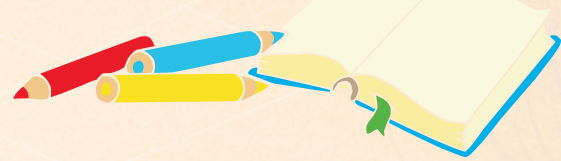
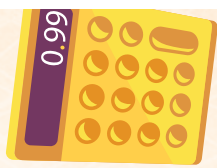

Q.5 The diagram below represents the fossilised skulls of three different species of primates. They were either bipedal or quadrupedal (organisms that habitually walk on all four limbs).

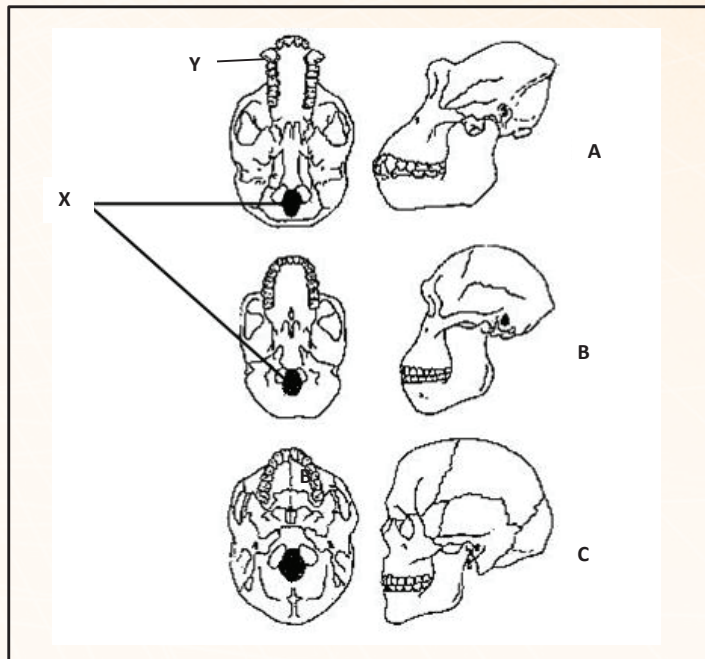

- 5.1 Label part **X** and the type of teeth at **Y**. (2)
- 5.2 Explain the significance of the location of structure **X** in organism **C**. (3)
- 5.3 Which of the skulls (**A**, **B** or **C**) belongs to:
- (a) an *Australopithecine* (1)
 - (b) a quadrupedal primate (1)
- 5.4 Explain how the change in the skull from **B** to **C** could indicate a change in intelligence. (3)
- 5.5 Tabulate TWO observable differences, other than those mentioned in QUESTIONS 5.2 and 5.4, between skulls **B** and **C** that represent trends in human evolution. (5)
- (15)**

(DBE, June 2016, Paper 2)

Q.6 Humans and African apes share many characteristics, yet each is a distinct species.

- 6.1 Name FIVE characteristics that humans share with African apes. (5)
- 6.2 Describe the differences between humans and apes in terms of each of the following structures:
- (a) spine (2)
 - (b) pelvic girdle (2)





6.3 Explain the significance of the changes to the teeth of humans, which shows progression in evolution. (4)

(13)

(DBE, November 2016, Paper 2)

Q.7 Fossils of the bipedal primates *Ardipithecus*, *Australopithecus* and early *Homo* species are used to support the 'Out of Africa' hypothesis.

State the 'Out of Africa' hypothesis. Describe the evidence that supports the 'Out of Africa' hypothesis and the evidence that shows that the three primate genera mentioned above were all bipedal.

Content: (17)

Synthesis: (3)
(20)

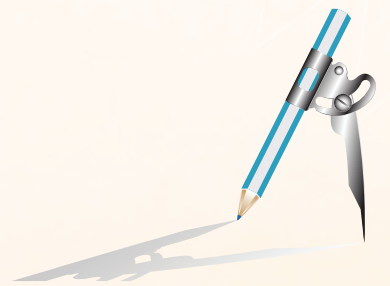



5 CHECK YOUR ANSWERS SET 1 (MASTER 40%)

Life Sciences Paper 1 – answers to the questions

Meiosis

Question 2

- 2.1 Spermatogenesis✓ (1)
 - 2.2 Testis✓ (1)
 - 2.3 (a) 23✓ (1)
 - (b) 2 \times ✓ (1)
 - 2.4 - Crossing over✓ (1)
 - Random assortment of chromosomes✓ (any order) (2)
 - 2.5 2✓ (1)
 - 2.6 Sperm cells✓/spermatozoa/male gametes (1)
- (8)**

Question 3

- 3.1 (a) Chromosome✓ (1)
 - (b) Spindle fibre✓ (1)
 - (c) Centromere✓ (1)
 - 3.2 Metaphase II✓ (1)
 - 3.3 Chromosomes lying independently✓/singly at the equator✓ (2)
- (6)**

Question 4

- 4.1 Prophase II✓/Telophase I (1)
- 4.2 (a) D✓ - centriole✓/(centrosome) (2)
- (b) B✓ - chromosome✓ (2)
- (c) E✓ - centromere✓ (2)
- 4.3 (a) 4✓ (1)
- (b) 2✓ (1)

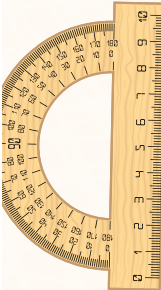

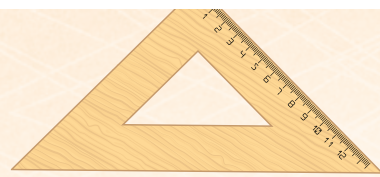

(9)

Human reproduction

Question 2

2.1 (a) Nucleus✓ (1)

(b) Tail✓ (1)

2.2 - C/ middle piece contains mitochondria✓ that provides energy for movement✓

- Has a tail✓ for swimming✓

- Torpedo shape✓ for reducing friction✓ Any (1 x 2) (2)

2.3 - No acrosome✓ will be present in the sperm cell

- therefore no enzymes present✓

- Sperm cell will be unable to penetrate the ovum✓

- *therefore, no fertilisation will occur✓ *compulsory mark + any other 2 (3)

(7)

Question 3

3.1 (a) Jelly✓ layer/zona pellucida (1)

(b) Cell membrane✓/plasma-lemma/plasma membrane (1)

(c).Cytoplasm✓/cytosol(1)

(d)Nucleus✓ (1)

3.2 (a) G✓ - Middle piece✓/neck

OR

C✓ - Cytoplasm✓ (2)

(b) E✓ - Acrosome✓ (2)

(c) D✓ - Nucleus✓ (2)

Responding to the environment (Humans)

Question 2

2.1 (a) Medulla oblongata✓ (1)

(b) Corpus callosum✓ (1)

(c) Cerebellum✓ (1)





2.2

- Controls all voluntary activities ✓/example
- It contains centres that receive and interpret all sensations ✓/example
- It is the seat of higher mental functions ✓/example
- Influences emotional behaviour/ example (Any 3)

(3)

(6)

Question 3

3.1 A – Ciliary ✓muscle/(body)

B – Iris ✓

E – Choroid ✓

(3)

3.2 (a) F ✓

(1)

(b) D ✓

(1)

(c) C ✓

(1)

(d) A ✓

(1)

(7)

Question 4

4.1 A - Pinnaü

D - Semi-circular canalü

(2)

4.2 (a) B

(1)

(b) G

(1)

(c) F

(1)

(d) C

(1)

(e) E

(1)

(7)





Question 5

1.1 Motor✓/multi-polar /efferent (1)

1.2 - Transmits the impulse away from the cell body.✓
- Transmits the impulse to the effector.✓ Any 1 (1)

(2)

Human endocrine system and Homeostasis in Humans

Question 2

2.1 The process by which the human body is able to maintain a constantP internal environment.P (2)

2.2 (a) Kidney✓ (1)

(b) Adrenal gland (1)

(c) Aldosterone (1)

2.3 - Walls of renal tubules
- become more permeable
- allowing for greater re-absorption of sodium ions
- from the filtrateP/into the blood capillaries Any 2 (2)
(7)

Question 3

When thyroxin levels decrease,

- the pituitary gland is stimulatedü
- to produce more TSH
- High TSH levels stimulate the thyroid glandü
- to secrete more thyroxinü
- The thyroxin levels thus increase back to normalü (5)

Responding to the environment (Plants)

Question 2

- Auxins✓





- are sensitive to light✓
- Light stimulus from one side causes auxins to move to the shaded side✓/destroyed on the illuminated side
- Auxin concentration is higher on the shaded side✓
- This promotes cell elongation✓ on the shaded side of the plant resulting in more growth✓ on this side.
- The stem grows towards the light stimulus.✓
- This is called phototropism.✓ (Any 4) (4)

Human impact on the environment

Question 2

2.1

- Food security refers to access✓
- to adequate✓/safe/nutritious food
- by all people at all times✓ (Any 2) (2)

2.2

- The price is higher to cover the cost of transportation✓ of goods over long distances.
- No competition✓ between dealers in rural areas.
- Decreased demand✓ for goods in rural areas. (Any 1) (1)

2.3

- Decreased need to buy food.✓
- Selling of excess produce to earn some money.✓ (2)

2.4

- Making people aware of the benefits of farming.✓
- Providing resources✓/example.
- Help rural people develop the skills needed for farming.✓
- Providing incentives✓ to encourage farming. (Any 2) (2)

(7)

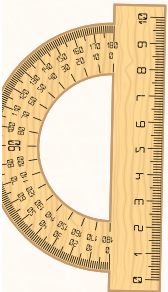



Life Sciences Paper 2 – answers to the questions

DNA: Code of Life

Question 2

- 2.1 (a) W – Nucleotide✓ (1)
 U – DNA✓ (1)
- (b) X – Phosphate✓/phosphate ion (1)
 Y – Deoxyribose✓sugar (1)
- (c) Z – Hydrogen✓ bond (1)
- (d) V – Adenine✓ (1)
- 2.2 Nucleus ✓ (1)
- 2.3 Interphase ✓ (1)
- (8)**



Question 4

- 4.1 Translation✓ (1)
- 4.2 X - tRNA✓/ transfer RNA (1)
 Y - mRNA✓/ messenger RNA (1)
- 4.3 Anticodon✓ (1)
- 4.4 ATA✓ (1)
- 4.5 Tyrosine✓✓ (2)
- 4.6

- **The process is transcription✓***
- The double-stranded DNA molecule unwinds✓/unzips
- When the hydrogen bonds break✓
- One strand is used as a template✓
- to form mRNA ✓
- Using free nucleotides✓ from the nucleoplasm
- The mRNA is complementary to the DNA✓/ A-U, C-G





- This process is controlled by enzymes. □

(5)

Genetics

Question 3

P₁ phenotype Black x Brown ✓
genotype Bb x bb ✓

Meiosis

G B, b x b ✓

Fertilisation

F₁ genotype Bb and bb ✓
phenotype Black and brown ✓

gametes	b
B	Bb
b	bb

OR

1 mark for correct gametes
1 mark for correct genotypes

1 mark for stating P₁ and F₁
1 mark for stating meiosis and fertilisation

any (

Question 4

4.1 I^A ✓, I^B ✓, i ✓ (3)

4.2 2 ✓ (1)

4.3

- An individual inherits one allele ✓
- from each parent ✓ (2)

4.4

- Each child ✓
- has an equal ✓ / 25% chance of having
- any blood group ✓ / A, B, AB, or O. (3)

(9)

Evolution:

Question 1

1.1. A group of organisms of the **same** species ✓
that can interbreed to produce **fertile** offspring ✓ (2)

1.2

- crossing over ✓
- random arrangement ✓ of chromosomes

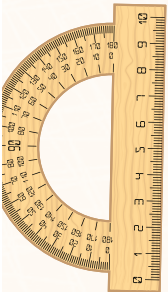

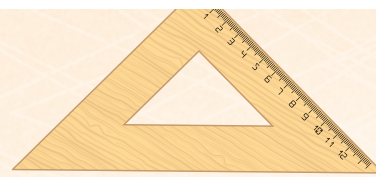

- independent assortment / random segregation / random assortment
- mutations
- chance fertilization / random fertilization
- random mating

(Any 4)

(4)

1.3

(a) Speciation

(1)

(b)

- The **rocky island** / **geographic barrier**
- separated the fish into two populations
- with different environmental conditions on each side of the barrier.
- Each group underwent natural selection independently
- and developed different characteristics.
- The groups became genotypically
- and phenotypically different to each other,
- which prevented them from interbreeding and which led to the formation of a new species.

(6)

Question 2

2.1

- Characteristics that are desirable/beneficial to humans are being selected.
- The characteristics are chosen by humans. / It is an artificial process.
- It is not necessarily beneficial for the organism.

Any 2

(2)

2.2

- The long-term effects on health are unknown, which could lead to health problems in the future.
- The long-term effects on the environment are unknown, leading to environmental damage / loss of biodiversity / damage to ecosystems/nature.
- People are morally opposed as humans are interfering with nature / playing God / interfering with the rights of every species





- Initially it is an expensive process✓ and many people/countries may not be able to afford it.✓

(Any 2 x 2)

(4)

(6)

Question 3

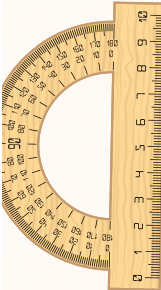

3.1 Phylogenetic tree✓

(1)

3.2

(a) 2✓

(1)

(b) 7✓

(1)

3.3

- *A. boisei* and *A. robustus* share a more recent✓

- common ancestorP

(2)

3.4 *Homo habilis*✓

(1)

3.5

Taung child✓

Mrs Ples✓

} *A. africanus*✓

Karabo✓ / *A. sediba*

Little foot✓ / *A. prometheus*

Any 2

(2)

3.6

- The **oldest** fossils of *Homo*✓ / *Homo habilis* / *Homo erectus*

- are found only in Africa. ✓

- The **younger** fossils of *Homo*✓ / *Homo erectus*

- were found in Africa and other parts of the world.✓

- This implies that the earliest *Homo* sp. evolved in Africa✓ / *Homo erectus* migrated out of Africa.

Any 3

(3)

(11)

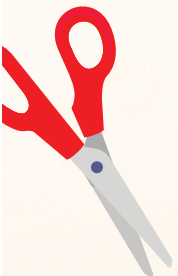



Question 4

4.1 A✓ and D✓ (2)

4.2

- The pelvis is wide✓/cup-shaped
- to support the weight✓ of an organism walking upright. (2)

4.3

Diagram A

- The foramen magnum is located centrally✓/in a more forward position below the skull
- so that the vertebral column originates beneath the skull✓
- for bipedalism✓

Any 2 (2)

Diagram B

- The foramen magnum is located towards the back✓ of the skull
- so that the vertebral column originates at the back of the skull✓
- for quadrupedal locomotion✓

Any 2 (2)

4.4

Diagram A	Diagram B
Gently curved✓/C-shaped jaw	Rectangular✓/U-shaped jaw
Small jaws✓	Large jaws✓
Smaller canines✓/(teeth)	Larger canines✓/(teeth)
No diastema/Fewer spaces between the teeth✓	Diastema present/Larger spaces between the teeth✓

Table format 1 + any 3 x 2 (7)

4.5 Any three of the following:

- freely rotating arm✓
- rotation around elbow joints✓
- rotation around the wrist✓
- bare fingertips/nails instead of claws✓
- long upper arms✓
- opposable thumbs✓
- five fingers✓

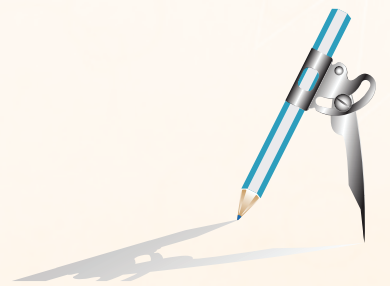



(3)

(18)

Question 5

5.1 X - Foramen magnum✓

Y - Canine✓

(2)

5.2

- The foramen magnum is located in a more forward position✓ below the skull,
- showing that organism C is bipedal.✓
- This allows for the vertebral column/spine to extend vertically✓ from the base of the skull.
- To balance the body weight when walking upright.✓ Any 3 (3)

5.3

(a) B✓

(1)

(b) A✓

(1)

5.4

- There is an increase✓
- in the cranium size✓ from organism **B** to organism **C**.
- This will allow it to house a larger brain✓/cerebrum, which suggests greater intelligence. (3)

5.5

Skull B	Skull C
Brow ridges are pronounced✓	Brow ridges are not as pronounced✓
More protruding jaws✓/larger jaws	Less protruding jaws✓/ smaller jaws

Table1 + (2 x 2)

(5)

(15)



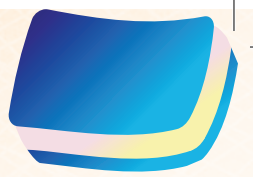
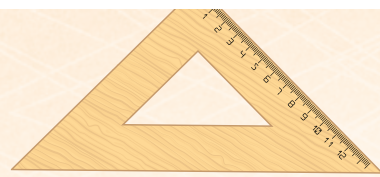

Question 6

6.1

- Eyes in front/binocular vision✓
- Freely rotating arms✓
- Long upper arms✓
- Bare fingertips or nails✓
- Opposable thumb✓
- Upright posture✓

(Any 5)

(5)



6.2

- (a) More curved spine✓/S-shape in humans but less curved✓/C-shaped in apes (2)
- (b) Short and wide✓ pelvis in humans, but long and narrow✓ pelvis in apes.✓ (2)

6.3

- Canines have changed from large✓
- to small✓.
- This is due to a change from eating raw✓ food
- to eating cooked✓ food.

(4)

(13)



Question 7

HYPOTHESIS

- **All modern humans✓/Homo sapiens**
- **originated in Africa✓**
- and migrated to other parts✓ of the world

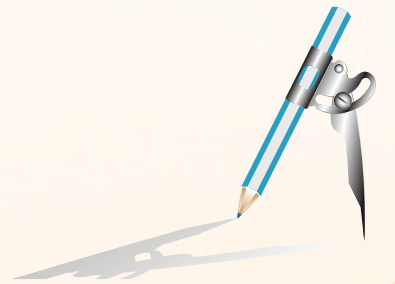



FOSSIL EVIDENCE ✓

- Fossils of *Ardipithecus* were found **ONLY** in Africa ✓ /the Rift Valley/Ethiopia/South Africa.
- Fossils of *Australopithecus* were found **ONLY** in Africa ✓ /the Rift Valley/Ethiopia/South Africa.
- The fossils of *Homo habilis* were **ONLY** found in Africa. ✓
- The **OLDEST** fossils of *Homo erectus* were found in Africa. ✓
- The **OLDEST** fossils of *Homo sapiens* were found in Africa. ✓

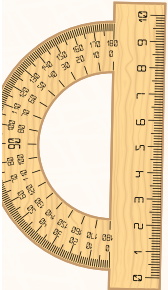

GENETIC EVIDENCE ✓

- Mitochondrial DNA ✓
- is inherited only from the maternal line. ✓
- Analysis of mutations ✓ on this mitochondrial DNA
- shows that the oldest female ancestors were located in Africa ✓
- and that all humans descended from her ✓ /mitochondrial Eve.



BIPEDALISM

The fossils of all three genera indicate that:

- The foramen magnum ✓
- is located in a more forward position ✓
- The pelvis ✓
- is wider and shorter ✓
- The spine ✓
- is S-shaped ✓



Content:

(17)

Synthesis:

(3)

(20)





Criterion	Relevance (R)	Logical sequence (L)	Comprehensive (C)
Generally	All information provided is relevant to the question.	Ideas are arranged in a logical sequence.	All aspects of the essay have been sufficiently addressed.
In this essay, in Q4	Only information relevant to the 'Out of Africa' hypothesis and bipedal fossils of the three genera are described. No irrelevant information is included.	The description of the evidence for the 'Out of Africa' hypothesis and the evidence of bipedalism is presented in a logical and sequential manner.	At least the following marks should be obtained: - 7/11 for the 'Out of Africa' hypothesis and the evidence - 4/6 on evidence for bipedalism.
Mark	1	1	1





6 REVISION QUESTIONS SET 2 (MASTER AN ADDITIONAL 20%)

6.1 INTRODUCTION

In Life Sciences 25% (38 marks) of EACH paper is allocated to questions set on understanding the content that you have studied. The content you need to study to achieve at least 38 marks can be found in the *Life Sciences MTG Study Guide*.

These 38 marks are spread across the questions in each paper. These understanding questions are addressed throughout sections A, B and C.

In this section, we will give examples of these understanding questions in each paper. Tips will be provided on how to approach answering these questions.

PAPER 1

A. SKILLS:

Study the section on drawing different types of graphs in the *MTG Study Guide* (p.105 - 110) to enable you to draw different types of graphs. It is easy to get full marks for drawing graphs if you follow the steps outlined in the *MTG Study Guide*.

(DBE, June 2015, Paper 1)

Q.1 The table below shows the concentration of abscisic acid and gibberellins in germinating seeds over 10 days.

TIME (DAYS)	HORMONE CONCENTRATION IN GERMINATING SEEDS (ARBITRARY UNITS)	
	ABSCISIC ACID	GIBBERELLINS
0	20	0
2	8	1
4	4	4
6	3	7
8	2	10
10	1	12

[Adapted from *Biology Cambridge*, 2013]

1.1 Draw a line graph to show the changes in the concentration of abscisic acid over the period of the investigation. (6)

1.2 State what happened to the concentration of each of the following hormones over the period of the investigation:

(a) Gibberellins (1)

(b) Abscisic acid (1)

(8)





(DBE, November 2015, Paper 1)

Q.2 One of the challenges in South Africa is access to food by the poor. In 2009, Statistics SA conducted a survey to determine the percentage of households in each province that had access to food.

The results are shown in the table below:

PROVINCE	HOUSEHOLDS THAT HAVE ACCESS TO FOOD (%)
Western Cape	85
Eastern Cape	79
Mpumalanga	79
Free State	67
Northern Cape	75
North West	79
KwaZulu-Natal	77
Limpopo	88
Gauteng	82

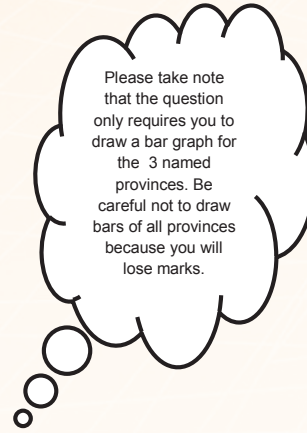

2.1 DRAW a bar graph to compare access to food in the following **three provinces**: Limpopo, Northern Cape and Free State. (6)

Q3 The table below shows the percentage of carbon dioxide (CO₂) emitted by different sectors in a certain city in South Africa.

SECTOR	CO ₂ EMISSION (%)
Transport	25
Residential	27
Industrial	15
Commercial	28
Other	5

[Adapted from *Energy scenarios for CT to-2050*, 2011]

3.1 Draw a pie chart to represent the data in the table above. Show ALL calculations. (7)

B. INTERPRETING TEXT:

Q.4 Read the extract below.



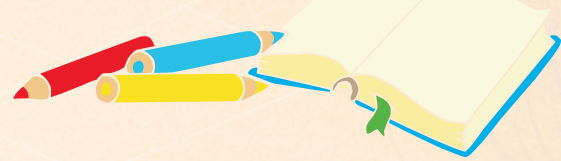
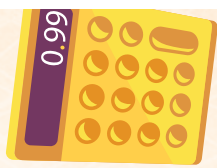

FOOD SECURITY IN SOUTH AFRICA

One of the challenges in South Africa is access to food by the poor. In 2009, Statistics SA conducted a survey to determine the percentage of households in each province that had access to food.

The results are shown in the table below:

PROVINCE	HOUSEHOLDS THAT HAVE ACCESS TO FOOD (%)
Western Cape	85
Eastern Cape	79
Mpumalanga	79
Free State	67
Northern Cape	75
North West	79
KwaZulu-Natal	77
Limpopo	88
Gauteng	82

South Africa seems to have adequate food access in urban areas, but the same cannot be said of households in rural areas. In rural areas, the price of staple foods (e.g. maize and rice) is usually higher than in urban areas.

Increasing agricultural activity is the key to food security and poverty alleviation. The majority of people living in rural areas have access to land, but more needs to be done to make household farming (growing crops for family use only) in these areas more efficient.

[Adapted from *Food Security*, Department of Agriculture, Forestry and Fisheries, March 2011]

- 4.1 What is meant by *food security*? (3)
 - 4.2 Suggest ONE reason why food prices in rural areas are usually higher than food prices in urban areas. (1)
 - 4.3 State TWO ways in which household farming could reduce poverty. (2)
 - 4.4 Suggest TWO ways in which the Department of Agriculture can improve farming activity in rural areas. (2)
- (8)**

Q.5 Read the extract below.





WATER CRISIS IN SOUTH AFRICA

The impact of the water scarcity will be one of South Africa's biggest problems soon. Recently a province had to switch off the water supply because the dams were 'so close on the edge'. It is stated that people are using more water than what's available, i.e. the demand is higher than supply.

About 37% of the clean, drinkable water is being lost through poor infrastructure (leaking pipes, dripping taps) and wastage. About 60% is used for irrigation.

Industries and mines also contribute to the water crisis by polluting our water bodies. They generate harmful waste, which is sometimes dumped into water bodies, creating acid mine drainage. The impact of climate change also adds to the water crisis.

There is a suggestion that South Africa needs to work with neighbouring countries to come up with solutions to the problem. An example is to grow agricultural products in neighbouring countries that have a higher rainfall, and export the products to South Africa.

[Adapted from mg.co.za/article and www.news24.com]



- 5.1 Refer to the extract and state TWO causes of the water crisis facing South Africa. (2)
 - 5.2 State how importing agricultural products from neighbouring countries would reduce South Africa's water crisis. (1)
 - 5.3 Explain how switching off the water supply would affect the industries that depend on water. (2)
 - 5.4 The South African government could possibly solve the water crisis by increasing the cost of water. Suggest TWO ways in which this solution could help to reduce the water crisis. (2)
- (7)



Q.6 Read the extract below and answer the questions that follow.

- 6.1 Name ONE place in a plant where auxins are produced naturally. (1)
- 6.2 State ONE function of auxins that results in the growth of a plant. (1)
- 6.3 Describe TWO disadvantages of using herbicides that are NOT made of plant hormones. (4)
- 6.4 Explain why it would be a disadvantage for a farmer to use auxin herbicides in a field planted with beans that are dicotyledonous. (2)

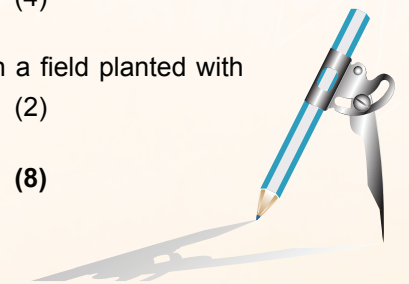

(8)



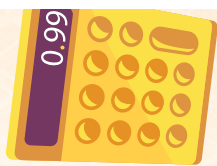
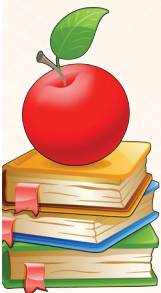

INTERPRETING QUESTIONS BASED ON DIAGRAMS:

Q.7 The diagrams below show two phases of meiosis in an animal cell.

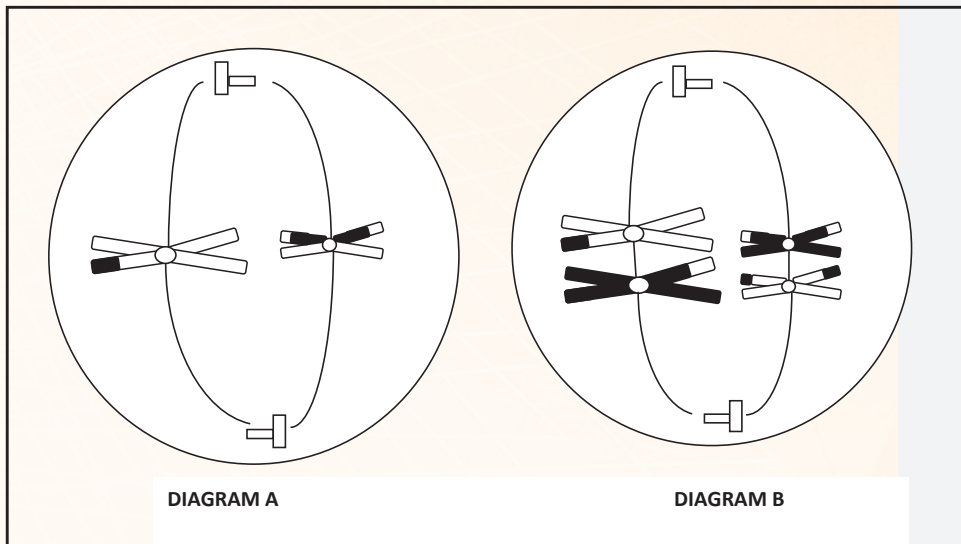

- 7.1 Identify the phase represented by **DIAGRAM B**. (1)
 - 7.2 Explain why the homologous chromosomes in **DIAGRAM B** have genetic material from each chromosome. (2)
 - 7.3 Name the phase that will follow the one represented by **DIAGRAM A**. (1)
 - 7.4 Describe the events that take place in the phase mentioned in QUESTION 7.3. (3)
 - 7.5 Name ONE place in a human male where meiosis takes place. (1)
- (8)**

Q.8 The diagram below represents one part of the negative feedback response that occurs when a person is dehydrated.

The decrease in blood volume, as a result of excessive loss of water, is detected by the brain.

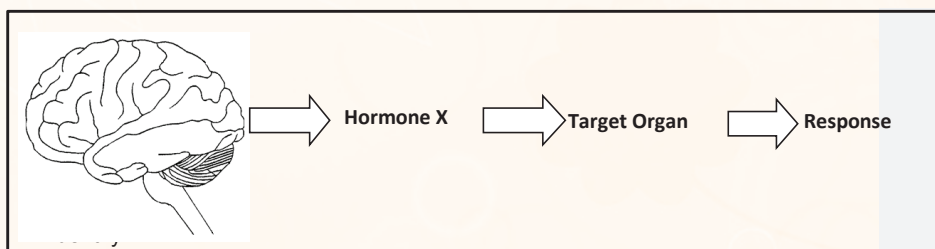

- 8.1 Identify the:
- (a) Hormone **X** (1)
 - (b) Endocrine gland that secretes hormone **X** (1)
 - (c) Target organ (1)





8.2 Describe the negative feedback response that occurs when a person is dehydrated and this is detected by the brain. (4)

(7)

C. ANSWERING ESSAY QUESTIONS:

Q.9 Describe the interaction and the influence of hormones on the events that occur during the menstrual cycle. Content: (17)

Synthesis: (3)

(20)



Q.10 While walking in the bush, Paul hears a sound that he thinks is the roar of a lion. He immediately runs to safety.

Describe how he hears the sound and describe the role of adrenalin in ensuring that his muscles are able to function efficiently while he runs away.

Content: (17)

Synthesis: (3)

(20)



PAPER 2

A. DNA: Code of life

Q.1 The diagram below shows the process of protein synthesis.

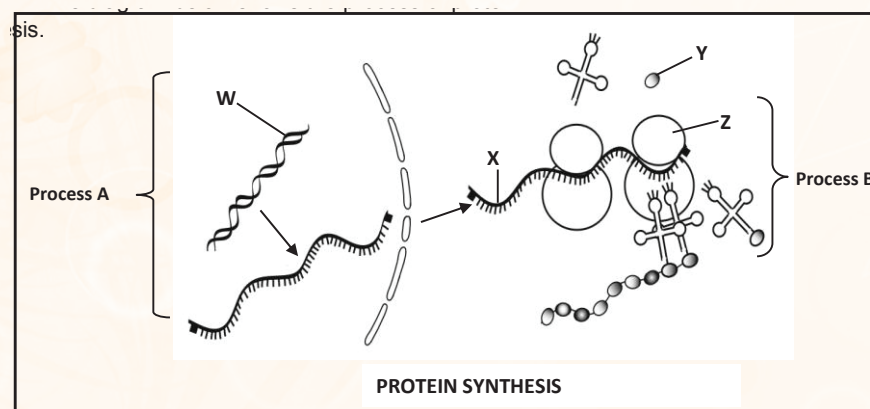

1.1 IDENTIFY THE FOLLOWING MOLECULES:

(A) W (1)

(B) Y (1)

1.2 Name the part of protein synthesis indicated by process A. (1)

1.3 Describe how a mutation on molecule W will affect the structure of the protein formed by process B. (4)





1.4 The following sequence represents a part of the nitrogenous base sequence on molecule X.

AGA	AUG	GGA
triplet 1	triplet 2	triplet 3

(A) WRITE DOWN THE BASE SEQUENCE OF THE ANTICODON OF TRIPLET 1 SHOWN ABOVE. (1)

(b) The table below shows the amino acids that correspond with different DNA codes.

AMINO ACID	DNA CODE
Arginine	TCT
Glycine	CCT
Methionine	TAC

Write down the correct sequence of amino acids for triplets 1 to 3. (3)

Q.2 The table below shows a partial DNA sequence for a human, as well as a codon table that can be used to determine which amino acids are required to make a protein.

BASE TRIPLET NUMBER	1	2	3	4	5	6	7
HUMAN DNA SEQUENCE	ATG	TGT	CCA	TTA	ACG	TGC	ACA

CODON TABLE	
Valine	GUU, GUG, GUA
Cysteine	UGU, UGC
Proline	CCA, CCU
Leucine	UUG, CUC, CUG, UUA
Threonine	ACG, ACA
Tyrosine	UAC, UAU

2.1 State ONE way in which the DNA molecule is biologically important. (1)

2.2 Name the codon that is formed from base triplet number 2 on the DNA sequence. (1)

2.3 Write down the names of the amino acids coded for by base triplets 6 and 7. (2)

2.4 If a mutation changes base triplet 1 from ATG to ATA, why will this not change the protein formed? (2)

2.5 Describe the process of translation in protein synthesis. (5)

(11)

Q.3 The diagram below shows the DNA profiles of six members of a family. The greater the similarity in the position of the bands in the DNA profiles of different individuals, the more closely they are related.

The parents, Zinhle and Ayanda, have four children. Two of the children are their biological offspring, while the other two children are adopted.

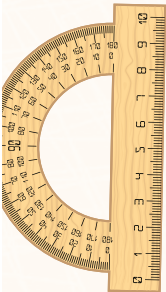

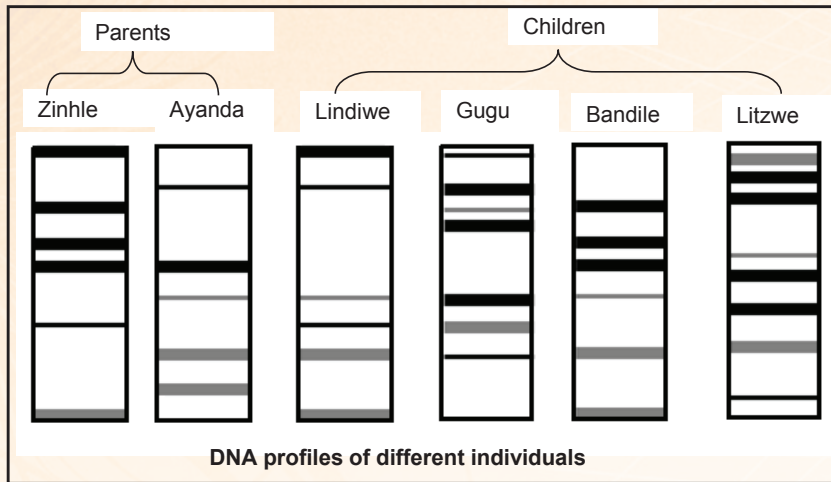

3.1 WHICH TWO CHILDREN ARE THE BIOLOGICAL OFFSPRING OF ZINHLE AND AYANDA? (2)

3.2 Give an explanation for your answer to QUESTION 3.1 using evidence from the DNA profiles. (2)

3.3 Apart from paternity testing, state TWO ways in which DNA profiling is of use to humans. (2)

(6)

B. GENETICS

Q.4 IN RABBITS, BLACK FUR IS PRODUCED BY THE ALLELE (B) AND WHITE FUR BY THE ALLELE (b).

The table below shows the genotypes of some rabbits.

RABBIT	GENOTYPE
1	BB
2	Bb
3	bb

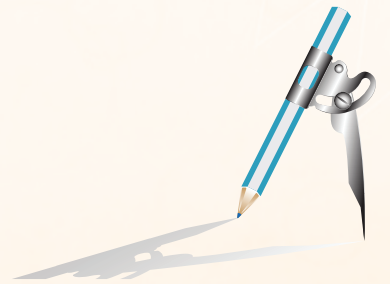

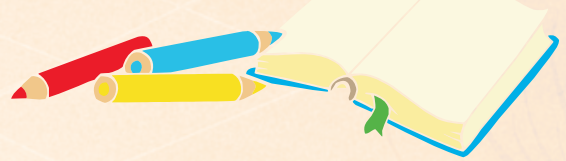
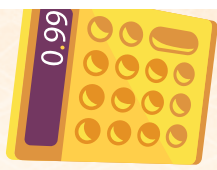

4.1 What is the phenotype:

(a) produced by the recessive allele

(1)

(b) of rabbit 2

(1)

4.2 Give the NUMBER only (1, 2 or 3) of the rabbit(s) that is/are:

(a) homozygous

(B) **HOMOZYGOUS DOMINANT**

(3)

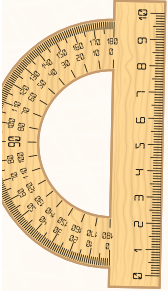



4.3 Use a genetic cross to show the percentage chance of rabbits **1** and **3** having offspring with white fur. (6)

(11)

Q.5 A grey (**G**) male rabbit was mated with a white (**g**) female rabbit. The entire F_1 generation was grey. Use a genetic cross to show the phenotypic ratio of their offspring if one of the males of the F_1 generation were mated with a white female.

(7)

Q.6

6.1 The pedigree diagram below shows the inheritance of colour-blindness in a family. Colour-blindness is sex-linked and is caused by a recessive allele (**d**). The ability to see colour normally is caused by a dominant allele (**D**).

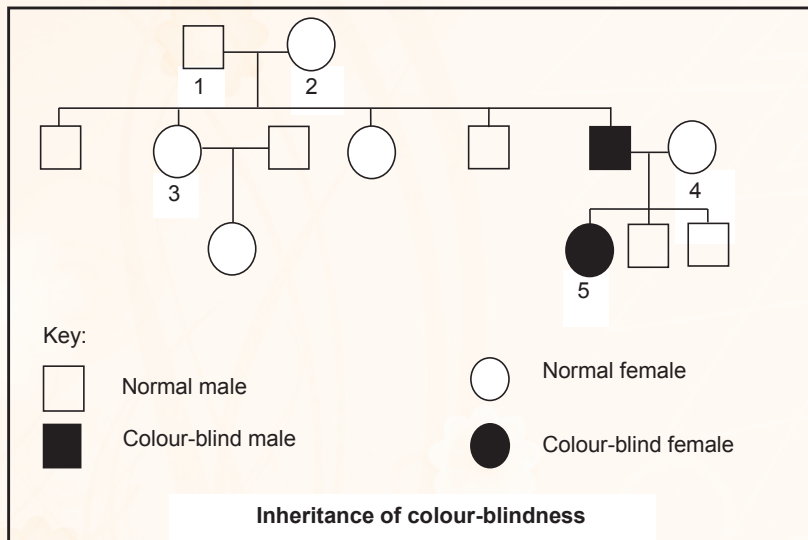

6.1 How many of the male offspring of parents **1** and **2** were normal? (1)

6.2 State the genotype of:

(a) Individual **2** (2)

(b) Individual **5** (2)



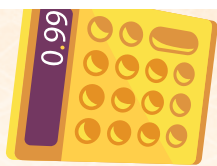

Q.7 Albinism is an inherited condition caused by a recessive gene mutation. This mutation results in the absence of the protein melanin in the skin. The pedigree diagram below shows the inheritance of albinism in a family. The genotype of James is shown in the diagram.

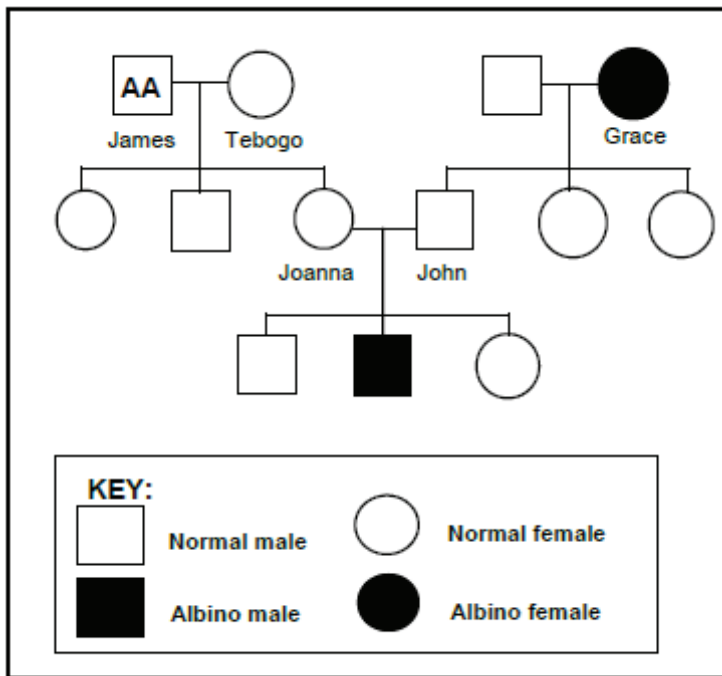

7.1 How many grandsons do James and Tebogo have? (1)

7.2 What is:
 (a) Grace's phenotype (1)
 (b) John's genotype (2)

7.3 John and Joanna wish to have another child. What is the percentage chance that the child will:
 (a) Be a girl (1)
 (b) Have albinism (1)
(6)

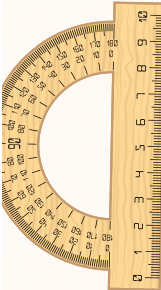



C. Evolution

Q.8 The extract and diagram below provide information about a type of antelope called a Bongo.

The Bongo is a large antelope species that is active at night and found in the dense jungles and forests of Africa. The dense forests have very little ground vegetation, so the Bongo feeds in forest openings where new herbs and shrubs grow closer to the ground. They are preyed on by lions and leopards.

Light brown coat and mane with white stripes

Short, brown tail with black tip

Dark brown belly

Black and white markings on the face, chest and legs

Horns that can be laid flat along the back when running through dense vegetation



8.1 STATE TWO CHARACTERISTICS THAT HELP THE BONGO TO CAMOUFLAGE THEMSELVES IN THE DENSE JUNGLE. (2)

8.2 USE YOUR KNOWLEDGE OF NATURAL SELECTION AND EXPLAIN HOW THE BONGO'S ABILITY TO LAY ITS HORNS ALONG ITS BACK COULD HAVE DEVELOPED OVER THE YEARS. (5)

(5)

(7)

Q.9 Lizards of a certain species on an island are usually brown in colour. A mutation in one gene for body colour results in red or black lizards. Black lizards camouflage well against the dark rocks and warm up faster on cold days, which will give them energy to avoid predators.

Scientists investigated the relationship between the colour of lizards in a population and their survival rate on an island. The results of the investigation are shown in the table below.

COLOUR OF LIZARDS	PERCENTAGE (%) OF EACH COLOUR IN THE POPULATION			
	Initial population	10 th generation	20 th generation	30 th generation
BROWN	80	80	70	40
RED	10	0	0	0
BLACK	10	20	30	60

[Adapted from <http://.hhmi.org/biolactive/>]



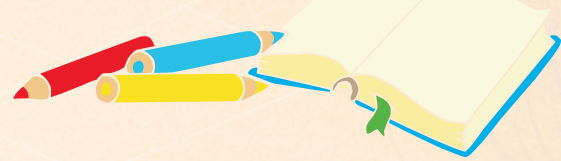
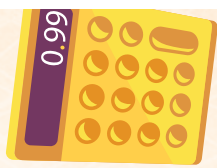

9.1 Use the theory of natural selection to explain the higher percentage of black lizards in the population of the 30th generation. (6)

Q.10 THE DIAGRAM BELOW SHOWS THE DISTRIBUTION OF MEMBERS OF THE CAMEL FAMILY ON THE DIFFERENT CONTINENTS. THE ARROWS INDICATE THE CURRENT DISTRIBUTION OF THE ANIMALS.

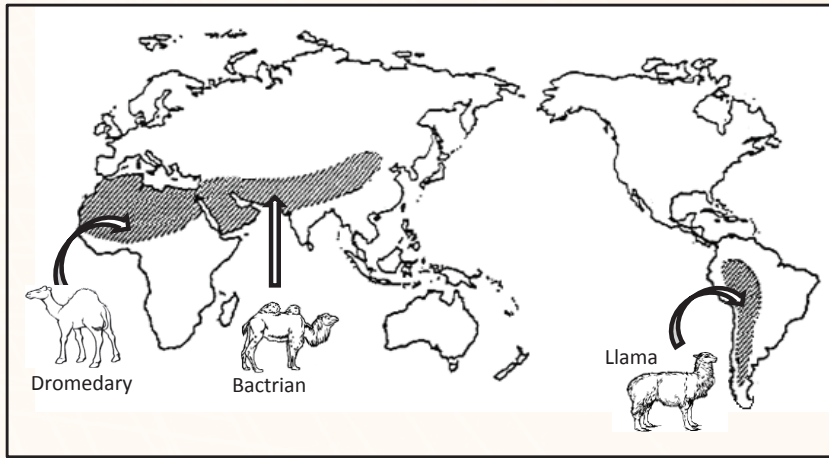

[Adapted from <http://www.ck12.org>]

10.1 Explain how speciation of camels may have occurred. (6)

7 CHECK YOUR ANSWERS SET 2

PAPER 1 MEMORANDUM

Question 1

1.1

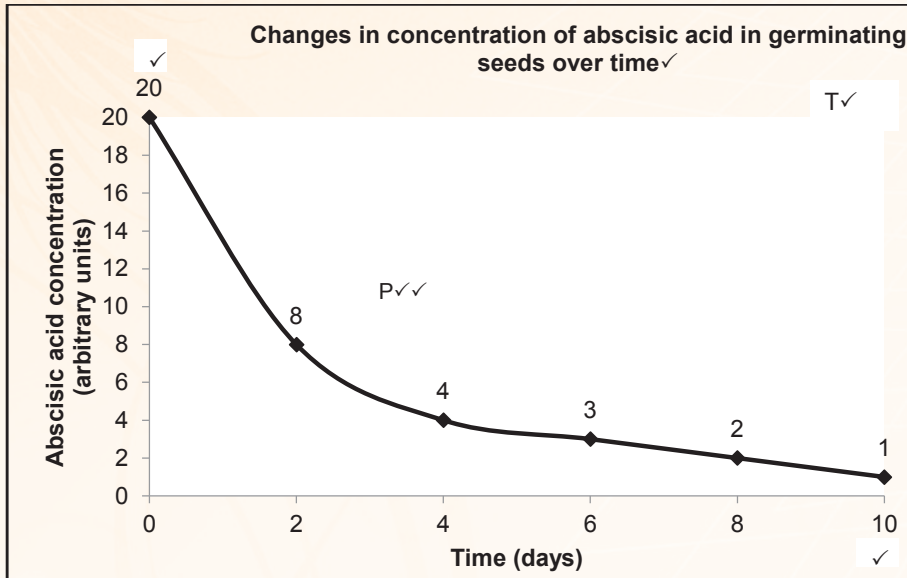

Mark allocation for the graph:

CRITERIA	Mark Allocation
CORRECT TYPE OF GRAPH, INCLUDING POINTS BEING JOINED.	1
Title of graph	1
Correct scale, label and unit for X-axis	1
Correct scale, label and unit for Y-axis	1
Drawing the graph	0: No points plotted correctly 1: 1 to 5 points plotted correctly 2: All 6 points plotted correctly

- 1.2 (a) Increased ✓
(b) Decreased ✓

(6)

(1)

(1)

(8)

Question 2

2.1

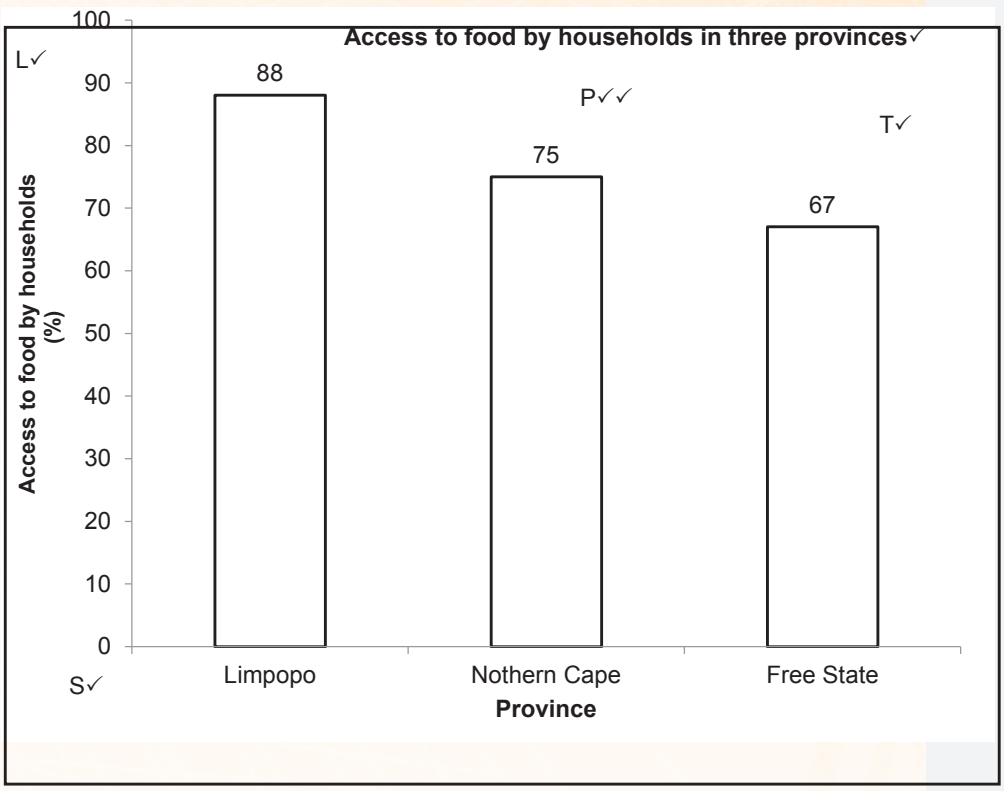
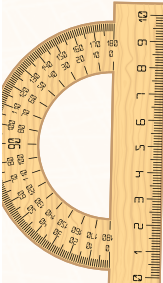
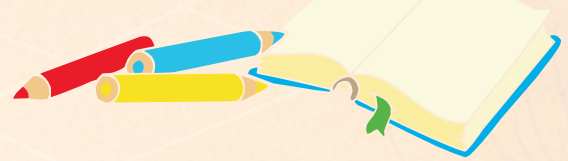
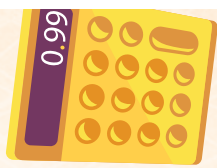

Mark allocation for the graph:

CRITERIA	Mark Allocation
BAR GRAPH DRAWN (T)	1
Title of graph	1
Correct scale for X-axis (equal width and spacing of the bars) and Y-axis (S)	1
Correct label and unit for X-axis and Y-axis (L)	1
Plotting of bars (P)	0: No bars plotted correctly 1: 1 to 2 bars plotted correctly 2: All 3 bars plotted correctly

Question 3

3.1

Calculations:

- Transport = $25/100 \times 360^\circ = 90^\circ$
- Residential = $27/100 \times 360^\circ = 97,2^\circ$
- Industrial = $15/100 \times 360^\circ = 54^\circ$
- Commercial = $28/100 \times 360^\circ = 100,8^\circ$



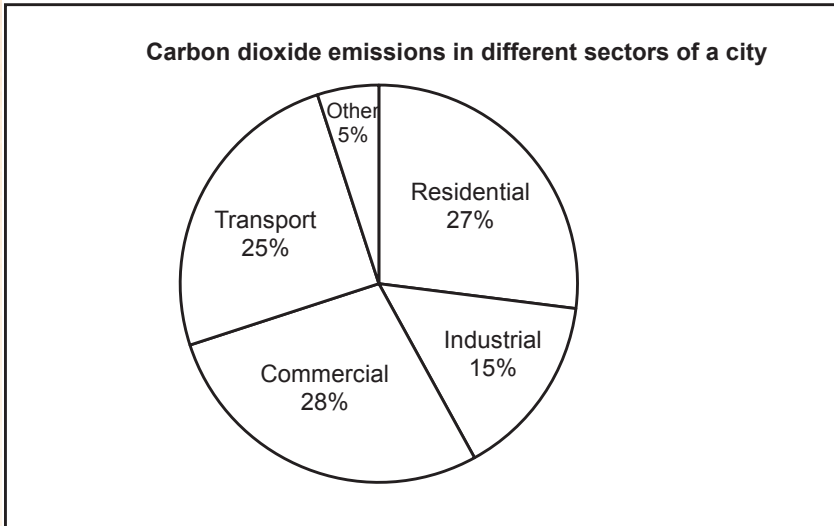

Mark allocation for the pie chart:		(7)	
CORRECT TYPE OF GRAPH	1		
Title of graph (CO ₂ emission + Sector)	1		
Calculations:	1: 1-4 calculations correct 2: All 5 calculations correct		
Correct proportion for each labelled slice	1: 1 to 2 slices correct 2: 3 slices correct 3: 4-5 slices correct		



Question 2

4.1

- Food security refers to access✓
- to adequate✓/safe/nutritious food
- by all people at all times.✓

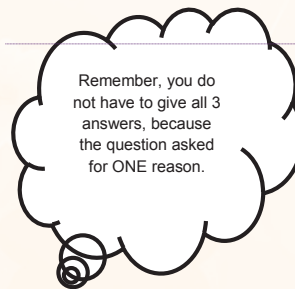

(3)

4.2

- The price is increased to cover the cost of transportation of goods✓ over long distances.
- No competition✓ between dealers in rural areas.
- Lower demand✓ for goods in rural areas. (Any 1)



(1)





4.3

- Less need to buy food.✓
- Selling of excess produce to earn some money.✓

(2)

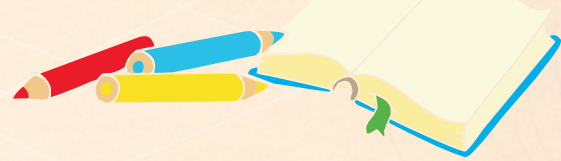
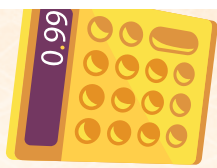

4.4

- Making people aware of the benefits of farming.✓
- Providing resources✓/example.
- Helping rural people develop the skills needed for farming.✓
- Providing incentives✓ to encourage farming.

(Any 2)

(2)

Question 5

5.1

- Poor infrastructure✓
- Climate change✓
- Wastage✓
- Pollution of water sources✓

(Any 2)

(2)

5.2

- The need for water irrigation will be reduced.✓

(1)

5.3

- Decreased production✓
- will lead to loss of profit.✓

(2)

5.4

- More revenue for fixing poor infrastructure✓/building dams.
- Less water wastage✓by individuals and companies.

(2)

(7)

Question 6

6.1 Apical tips✓/stem tips/root tips/bud

(1)

6.2 Promotes cell elongation✓

(1)

6.3



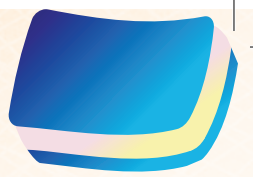
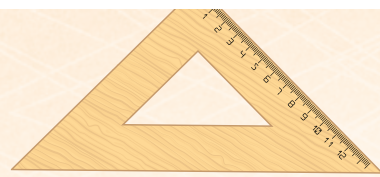

- Only kills part of a plant✓/leaves and stems, leaving the roots to grow again✓
- Poisonous✓
- can be harmful to other organisms✓

(4)

6.4

- It could kill the beans as well,✓
- thus reducing the crop yield.✓

(2)

Question 7

7.1 Metaphase I✓

(1)

7.2

- Crossing over has taken place✓
- and genetic material was exchanged.✓

(2)

7.3 Anaphase II✓

(1)

7.4

- The spindle fibres contract✓
- The centromeres split✓
- and pull the daughter chromosomes✓/chromatids
- to the opposite poles of the cells✓
- Cytokinesis begins✓

(Any 3)

(3)

7.5 Testes✓

(1)

(8)

Question 8

8.1

- (a) ADH✓/antidiuretic hormone
- (b) Hypothalamus✓/Pituitary gland
- (c) Kidneys✓

(1)

(1)

(1)

8.2

- An increase in ADH causes the walls of the kidney tubules✓
- to become more permeable✓ to water.





- More water is reabsorbed ✓
- and the blood volume increases. ✓
- Less urine is produced ✓
- and the urine is more concentrated. ✓

(4)

(7)

Question 9

- FSH ✓ / follicle stimulating hormone
- is secreted by the pituitary gland. ✓
- FSH stimulates the development of a primary follicle ✓
- into a Graafian follicle. ✓

- As the follicle develops, it secretes oestrogen, ✓
- which causes the lining of the uterus ✓ / endometrium
- to become thicker ✓ / more vascular
- in preparation for possible implantation of the embryo ✓ / development of the foetus.

- The pituitary gland ✓
- secretes LH, ✓
- which causes the Graafian follicle to rupture and release the ovum. ✓
- This is called ovulation. ✓

- The empty follicle changes and becomes a corpus luteum, ✓
- which begins to secrete progesterone. ✓
- This causes further thickening ✓
- of the endometrium ✓





- High levels of progesterone ✓
- inhibit the secretion of FSH, ✓
- which prevents the development of a new follicle in the ovary. ✓
- If there is no fertilisation, the corpus luteum degenerates, ✓
- which leads to a drop in progesterone. ✓
- The endometrium disintegrates and is shed during menstruation ✓
- If fertilisation occurs, the corpus luteum remains intact, ✓
- which leads to the levels of progesterone remaining high ✓
- to maintain pregnancy ✓



Content: (17)

Synthesis(3)

(20)



Relevance	Logical sequence	Comprehensive
All information provided is relevant to the topic.	Ideas are arranged in a logical/cause-effect sequence.	Learner has covered all aspects required by the instruction for the essay.
All information relevant to the events of the menstrual cycle only (not pregnancy) and the hormones FSH, LH, oestrogen and progesterone.	All events of the menstrual cycle are in sequence.	All FOUR correct hormones are mentioned, as well as their functions.
1 mark	1 mark	1 mark

Question 10

Hearing

- The pinna traps/directs sound waves ✓
- into the ear canal ✓ /meatus.
- This causes the tympanic membrane to vibrate. ✓
- The vibration is transmitted to the auditory ossicles. ✓
- The ossicles amplify the vibration ✓
- and transmit it to the oval window. ✓

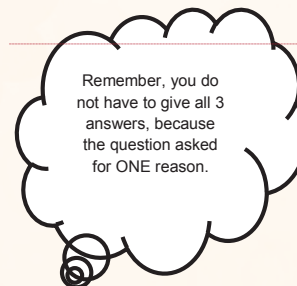

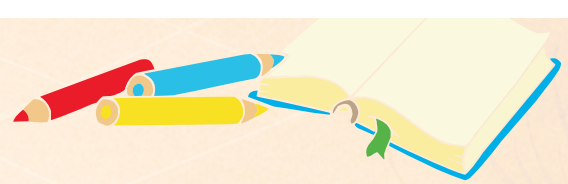

- The oval window vibrates,✓
- creating waves✓
- in the fluid/endolymph of the cochlea,✓
- which stimulate the Organ of Corti✓
- to convert the waves into an impulse.✓
- The impulse travels along the auditory nerve✓
- to the cerebrum,✓ where it is interpreted as the roar of a lion.

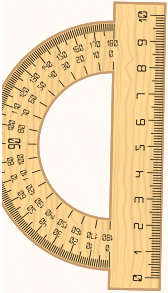

Role of Adrenalin

- More adrenalin is secreted.✓
- Adrenalin increases muscle tone✓
- and causes the liver/muscles to convert glycogen into glucose.✓
- The heart rate increases✓
- so that the muscles receive more glucose✓
- and oxygen,✓
- which is needed for cellular respiration✓
- to provide the energy✓ for the muscles to contract efficiently.
- The rate of breathing increases✓
- and the depth of breathing increases✓
- to exhale carbon dioxide from the muscles faster✓
- and to inhale oxygen faster.✓

- Constriction of blood vessels to the gut✓/skin
- and dilation of blood vessels to the vital organs✓/brain/muscles,
- allowing more blood to be supplied to the vital organs✓/brain/muscles.



Content: (17) Synthesis: (3)

(20)





Relevance	Logical sequence	Comprehensive
All information provided is relevant to the question.	Ideas are arranged in a logical/ cause-effect sequence.	The learner has answered all aspects required by the essay.
All the information provided is relevant to hearing and how adrenalin ensures that muscles function efficiently.	All information regarding hearing and how adrenalin ensures that muscles function efficiently is arranged in a logical manner.	At least the following marks should be obtained for each of the following: - Hearing (7/10) - How adrenalin ensures that muscles function efficiently. (4/7)
There is no irrelevant information.		
1 mark	1 mark	1 mark



PAPER 2 MEMORANDUM

Question 1

1.1

(a) DNA✓ molecule (1)

(b) Amino acid✓ (1)

1.2 Transcription✓ (1)

1.3

- The sequence of nitrogen bases on molecule W/DNA will change.✓
- This will cause a corresponding change on the molecule Xü/mRNA.
- The amino acid brought in by tRNA will be different.ü
- A different protein will form.ü (4)

1.4

(a) UCU✓ (1)

(b) Arginine✓; Methionine✓; Glycine.✓ (3)

(Answers must be in the correct order.)

(11)

Question 2

2.1

- DNA contains coded information for protein synthesis.✓
- DNA carries hereditary information.✓ (Any 1) (1)

2.2 ACA ✓ (1)

2.3 Threonine✓; Cysteine.✓ (Answers must be in the correct order.) (2)





2.4

- Both ATG and ATA.✓
- Code for the same amino acid/tyrosine.✓

(2)

2.5

- The anticodon on the tRNA matches the codon on the mRNA✓
- tRNA brings the required amino acid✓
- to the ribosome✓
- amino-acids are joined by peptide bonds✓
- to form the required protein✓

(5)

(11)

Question 3

3.1 Lindiwe✓ and Bandile✓

(2)

3.2 They have DNA bands that correspond✓ with the banding patterns seen in both parents✓ / Zinhle and Ayanda.

(2)

3.3

- To investigate crimes✓ / resolve disputes.
- To identify organisms from their remains.✓
- To identify family relationships other than paternity✓, e.g. siblings or cousins.
- To test for the presence of specific alleles✓ / genes that cause a genetic disorder.
- To establish matching tissues for organ transplants.✓

Any 2

(2)

(6)

Question 4

4.1

(a) White✓ fur

(1)

(b) Black ✓ fur

(1)

4.2

(a) 1✓ and 3✓

(2)

(b) 1✓

(1)

4.3

P₁ Phenotype Black X White✓
 Genotype BB X bb✓

Meiosis

G/gametes B, B X b, b✓

Fertilisation

F₁ Genotype Bb; Bb; Bb; Bb ✓
 Phenotype All black
 *0✓%white

P₁ and F₁✓
 Meiosis and fertilisation✓

(*compulsory mark + 5)

OR

P₁ Phenotype Black X White✓
 Genotype BB X bb✓

Meiosis

Fertilisation

Gametes	B	B
b	Bb	Bb
b	Bb	Bb

1 mark for correct gametes
 1 mark for correct genotypes

F₁ Phenotype All black
 *0✓% white

P₁ and F₁✓
 Meiosis and fertilisation✓

(* compulsory mark + 5)

(6) (11)

Question 5

P₂ Phenotype Grey male x White female✓
 Genotype Gg x gg✓

Meiosis

G/gametes G, g x g, g✓

Fertilisation

F₂ Genotype Gg; Gg; gg; gg ✓
 Phenotype 2 grey rabbits : 2 white rabbits ✓

Phenotypic ratio of offspring is *1 : 1✓

P₂ and F₂✓
 Meiosis and fertilisation✓

*1 compulsory + any 6

OR

P₂ Phenotype Grey male x White female✓
 Genotype Gg x gg✓

Meiosis

Fertilisation

Gametes	G	g
g	Gg	gg
g	Gg	gg

1 mark for correct gametes
 1 mark for correct genotypes

F₂ Phenotype 2 grey rabbits : 2 white rabbits ✓

Phenotypic ratio of offspring is *1 : 1✓

P₂ and F₂✓
 Meiosis and fertilisation✓

*1 compulsory + any 6

(7)



Question 6

6.1 2✓ (1)

6.2 (a) $X^D X^d$ ✓✓ (2)

(b) $X^d X^d$ ✓✓ (2)

(5)

Question 7

7.1 2✓ (1)

7.2 (a) Albino female✓ (1)

(b) Aa✓✓ (2)

7.3 (a) 50%✓ (1)

(b) 25%✓ (1)

(6)

Question 8

8.1

- Coat is light brownü on the upper side.
- Dark brown belly.ü
- White stripes on the back and mane.ü
- Black and white patches on the rest of the body.ü
- The tip of the tail is black.ü

Any 2 (2)

8.2

- There is variationü amongst the Bongo population.
- Some have horns that can be laid on their backs,✓
- while others do not have horns that can be laid on their backs.✓
- The antelope must move through dense vegetation✓ without their horns getting entangled in the vegetation.

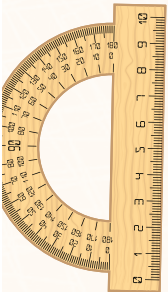



- Those with horns that cannot be laid on their backs become entangled✓/ die.
- Those with horns that can be laid on their backs do not become entangled and escape predators✓/ survive.
- Those with horns that can be laid back will reproduce✓
- and pass the gene for horns that can be laid on their backs to the next generation.✓

Over many years, the proportion of animals that are able to lay their horns on their backs increases.✓

(5)

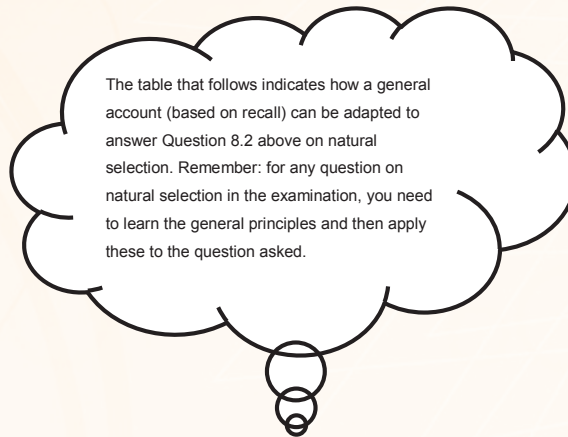

General Account on Natural Selection	Natural Selection in the bongo/antelope
There is variation amongst the offspring.	There is variation amongst the bongo population.
Some have desirable characteristics and some do not.	Some have horns that can be laid on their backs, whilst others cannot lay their horns on their backs.
Sometimes there is a change in environmental conditions that acts as selection pressure.	The antelope has to move through dense vegetation without becoming entangled to avoid being trapped and then caught by predators.
Organisms with characteristics that make them less suited to the environment will die.	Those with horns that cannot be laid on their backs become entangled and die.
Organisms with characteristics that make them more suited to the environment will survive.	Those with horns that can be laid on their backs do not become entangled and survive.

Question 9

9.1

- There is variation in colour amongst the lizards.
- ***Red and brown✓ lizards**
- ***are not camouflaged/ cannot warm up fast enough and so do not have the energy they need to run away**
- and are killed by predators.✓
- ***The black lizards✓**
- ***are better camouflaged✓/ warm up faster and so have enough energy to avoid predators**





- and survive✓/reproduce.
- The allele for black colour is passed on to the next generation✓
- to produce more black lizards✓ in the next generation.

(6)

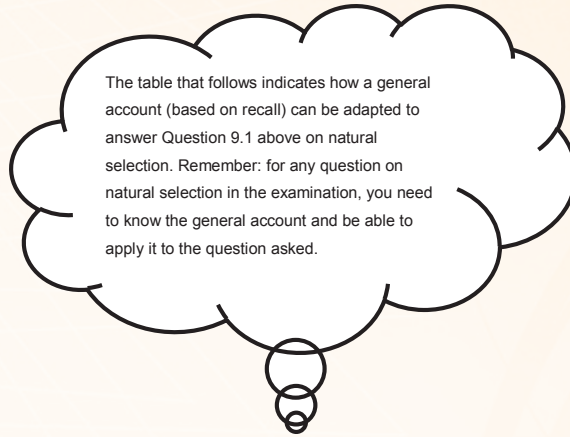
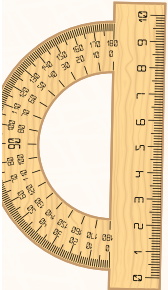

The table that follows indicates how a general account (based on recall) can be adapted to answer Question 9.1 above on natural selection. Remember: for any question on natural selection in the examination, you need to know the general account and be able to apply it to the question asked.



General Account on Natural Selection	Natural Selection in the Lizard Population
There is variation amongst the offspring.	There is variation amongst the lizard population.
Some have favourable characteristics and some do not.	Some are black and are better camouflaged/ warm up faster, which gives them energy to avoid predators, whilst others are red or brown and are NOT camouflaged/cannot warm up fast enough and so do not have the required energy to run away from predators.
Sometimes there is a change in environmental conditions, which acts as selection pressure.	Predation acts as the selection pressure. Survival depends on the colour of the lizards.
Organisms with characteristics that make them less suited to the environment will die.	Red and brown lizards are caught by predators and die.
Organisms with characteristics which make them more suited to the environment will survive.	Black lizards survive.
The organisms that survive will reproduce.	The surviving black lizards will reproduce.
They will pass on the favourable characteristic to their offspring.	The allele for black colour will be passed on to the next generation.
Over many generations, the proportion of individuals with the favourable characteristic, increases.	Over many generations, the proportion of lizards that are black, increases.

Question 10

10.1

- The common ancestor✓/original camel population
- was separated✓ into different populations
- ***by the sea✓/due to continental drift.**
- There was no gene flow✓ between the populations.

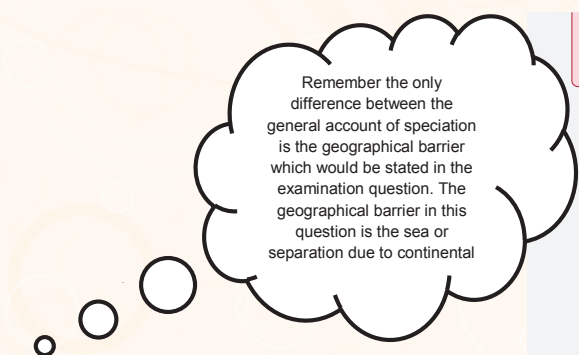

Remember the only difference between the general account of speciation is the geographical barrier which would be stated in the examination question. The geographical barrier in this question is the sea or separation due to continental





- Each population was exposed to different environmental conditions ✓ / selection pressures.
- Natural selection occurred independently ✓ in each population.
- The populations became different ✓ from each other over time
- genotypically and phenotypically. ✓
- Even if the three populations were to mix again ✓
- they would not be able to interbreed. ✓

(6)



6 Study and Examination Tips

A) Generic

- Time management etc.
- This should be the same for all subjects.
- DBE to draft

B) Subject specific

Refer to the *MTG Study Guide* (p.ix) for tips on how to study, as well as p.xiii for tips on what to do on the day of the exam.

STUDY TIPS

- Time management
 - Draw up a special study schedule
 - Select fixed study times
 - Break up topics into manageable sections
- How to study:
 - Set up a place to study: table, chair, uncluttered work space, good lighting
- Make your studying active by using study methods such as writing, drawing, summarizing, chanting or teaching a study buddy.

EXAM WRITING TIPS

- Arrive early and be ready to begin the exam. For Life Sciences papers, you must have a:
 - non-programmable calculator
 - pen (black or blue ink)
 - pencil
 - eraser



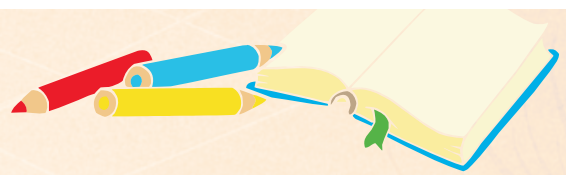

- ruler
- protractor
- compass

- Synchronize your watch with that of the examiner.

- READ and understand the instructions in the question paper.

- Preview the question paper and allocate your writing time appropriately.

- Tackle FIRST those questions you can answer BEST. Number your answers very clearly and answer an entire question at a time.

- Tackle each question systematically.

- Write down something for every question.

- Set out your answers clearly. Write legibly.

- Review your answers and make corrections.

7 **Message to Grade 12 learners from the writers**

Each developer should write a message of encouragement to the learners

Be funny, be witty, be creative.

Motivate the learners.

Inspire them to want to learn.

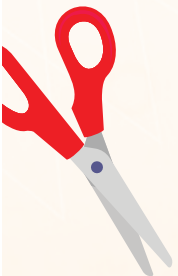
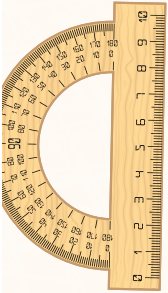



8 ACKNOWLEDGEMENT

The Life Sciences Exam Preparation Booklet was developed by, Ms Susan Wiese, Mr Gongsagaren Pillay and Mr Jean Goliath (Subject Specialists, PED)

A special mention must be made to Mr Kanthan Naidoo the DBE curriculum specialist who, in addition to his/her contribution to the development of the booklet, co-ordinated and finalised the process.

These officials contributed their knowledge, experience and in some cases unpublished work which they have gathered over the years to the development of this resource. The Department of Basic Education (DBE) gratefully acknowledges these officials for giving up their valuable time, families and knowledge to develop this resource for the children of our country.

Administrative and logistical support was provided by: Ms Martha Netshipale, Mr Itumeleng Jikolo, Ms Zanele Mkwanazi and Mr Noko Malope. These officials were instrumental in the smooth and efficient management of the logistical processes involved in this project.

Book III

Look out for Book II which will help you get from 60% to 80% or even 100% - wouldn't that be amazing.



32%



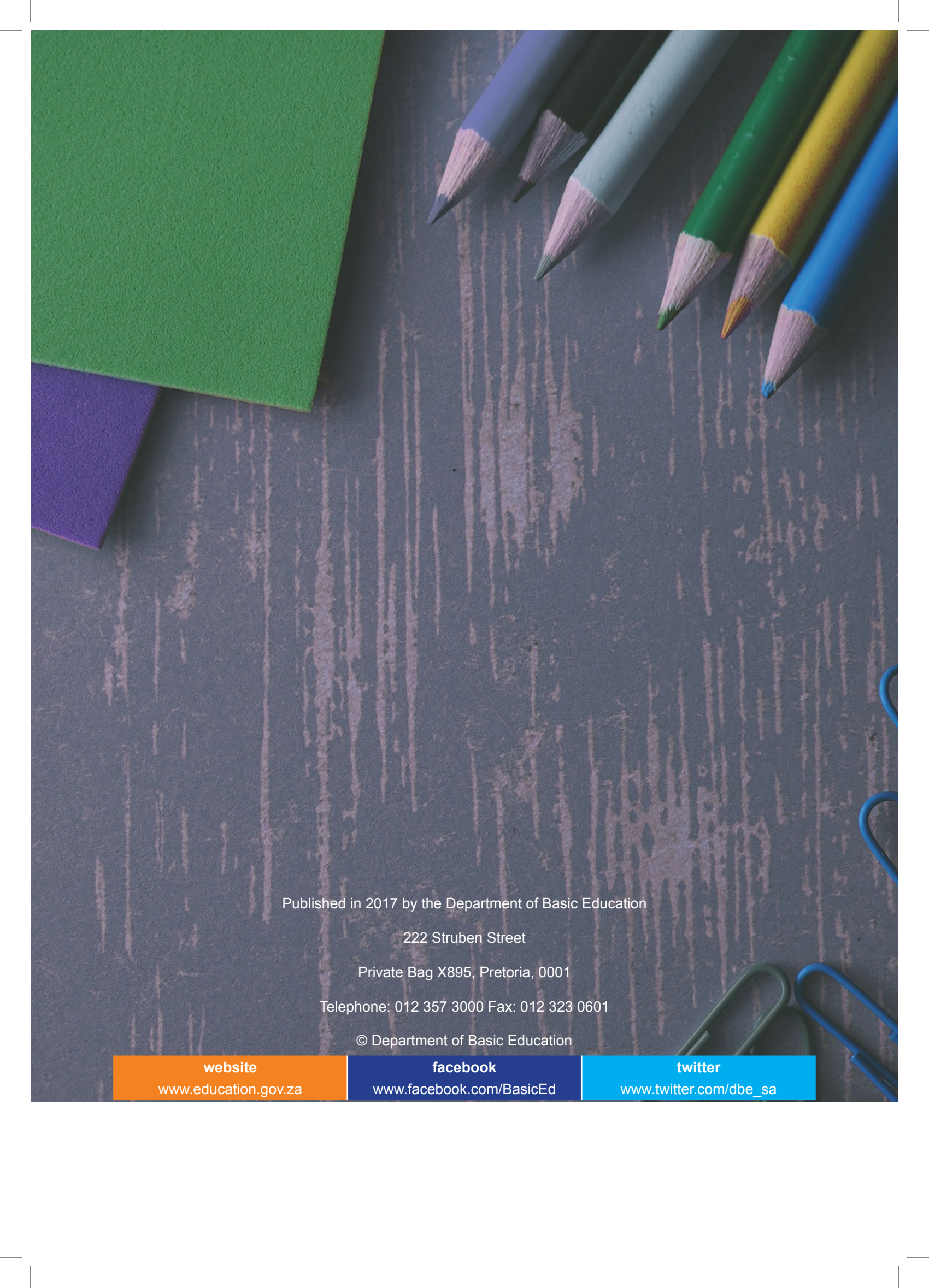

Published in 2017 by the Department of Basic Education

222 Struben Street

Private Bag X895, Pretoria, 0001

Telephone: 012 357 3000 Fax: 012 323 0601

© Department of Basic Education

website

www.education.gov.za

facebook

www.facebook.com/BasicEd

twitter

www.twitter.com/dbe_sa