



basic education

Department:
Basic Education
REPUBLIC OF SOUTH AFRICA

TECHNICAL MATHEMATICS

GUIDELINES FOR PRACTICAL ASSESSMENT TASKS

GRADE 12

2023

These guidelines consist of 29 pages.

TABLE OF CONTENTS

	Page
1. INTRODUCTION	3
2. TEACHER GUIDELINES	4
2.1 How to administer the PATs	4
2.2 Moderation of the PATs	4
3. LEARNER GUIDELINES	4
4. EVIDENCE OF MODERATION WITH MARK ALLOCATION AND DECLARATION OF AUTHENTICITY	5
5. CONCLUSION	6
6. TASKS:	7
• TASK 1: DIFFERENTIAL CALCULUS	7
• TASK 2: TRIGONOMETRY	17
• TASK 3: EUCLIDEAN GEOMETRY	23

1. INTRODUCTION

The 18 Curriculum and Assessment Policy Statement subjects which contain a practical component all include a practical assessment task (PAT). These subjects are:

- **AGRICULTURE:** Agricultural Management Practices, Agricultural Technology
- **ARTS:** Dance Studies, Design, Dramatic Arts, Music, Visual Arts
- **SCIENCES:** Computer Applications Technology, Information Technology, Technical Sciences, Technical Mathematics
- **SERVICES:** Consumer Studies, Hospitality Studies, Tourism
- **TECHNOLOGY:** Civil Technology, Electrical Technology, Mechanical Technology, Engineering Graphics and Design

A practical assessment task (PAT) mark is a compulsory component of the final promotion mark for all candidates offering subjects that have a practical component and counts 25% (100 marks) of the examination mark at the end of the year. The practical assessment task for Technical Mathematics Grade 12 consists of three tasks (one task per term) which should be completed by end of Term 3. The tasks are **COMPULSORY** for **ALL** candidates offering Technical Mathematics in Grade 12.

The PAT is implemented during the first three terms of the school year. The PAT allows learners to be assessed regularly during the school year and it also allows for the assessment of skills acquired and it applies the science of Mathematics to the technical field where the emphasis is on application. It is therefore important that schools ensure that all learners complete the practical assessment tasks within the stipulated period to ensure that learners are promoted at the end of the school year. The planning and execution of the PAT differ from subject to subject.

The tasks should be administered under supervised conditions. Moderation may be done onsite, at the school.

2. TEACHER GUIDELINES

2.1 How to administer the PATs

- The following documents must be available for all formal tasks:
 - Task instructions explaining the procedures to be followed
 - The worksheets which include questions to be answered under examination conditions
 - The teacher guidelines with task instructions, worksheets and marking guidelines (The teacher guidelines **MUST NOT** be released to the learners.)
 - Teachers should compile marking guidelines (memoranda) for the real results of the task conducted (Teachers should do the tasks themselves **FIRST**.)
- The tasks must be done individually. Each learner must record his/her **OWN INDIVIDUAL** data and observations.
- Each learner must have his/her **OWN** worksheet and answer the questions **INDIVIDUALLY** under examination conditions.
- Only once all the learners are ready to do the task and they are seated, ready to answer the questions, may teachers hand out a worksheet to each learner. Examination conditions have to be applied.
- If it is not possible to do the task and complete the worksheet on the same day, the teacher must collect the learners' tasks. These tasks must be kept at the school.

2.2 Moderation of the PATs

For moderation, the following documents are required in the teacher's file:

- Index indicating all tasks with raw and weighted marks
- All task instructions
- Marking guidelines for all tasks, with ticks and totals
- Composite working mark sheet for all learners showing raw and weighted marks
- Evidence of internal moderation

For moderation, the following documents are required in the learner's file:

- Index indicating all tasks with raw and weighted marks
- Answer sheets for all tasks

3. LEARNER GUIDELINES

3.1 This PAT for Grade 12 consists of **THREE** tasks.

3.2 The PAT contributes 25% towards your final promotion mark for Grade 12.

3.3 All individual work in the PAT must be your own.

3.4 Show **ALL** calculations clearly and include units. Round off answers to **TWO** decimal places. Use correct SI units where necessary.

4. EVIDENCE OF MODERATION

Learner's name:	
School:	

MARK ALLOCATION

TASK	MAX. MARK	WEIGHTING	LEARNER'S MARK (TEACHER)	MODERATED MARK (SCHOOL)	MODERATED MARK (DISTRICT)	MODERATED MARK (PROVINCE)
1	40	10				
2	30	7,5				
3	30	7,5				
TOTAL	100	25				
NAME						
SIGNATURES						
DATE						

DECLARATION OF AUTHENTICITY

I hereby declare that the project submitted for assessment is my own, original work and has not been submitted for moderation previously.

SIGNATURE OF LEARNER

DATE

As far as I know, the above declaration by the learner is true and I accept that the work offered is his/her own.

SIGNATURE OF TEACHER

DATE

SCHOOL STAMP

5. CONCLUSION

On completion of the practical assessment task learners should be able to demonstrate their understanding of the subject, enhance their knowledge, skills, values and reasoning abilities as well as establish connections to life outside the classroom and address real-world challenges. The PAT furthermore develops learners' life skills and provides opportunities for learners to engage in their own learning.

www.mycourses.co.za



basic education

Department:
Basic Education
REPUBLIC OF SOUTH AFRICA

TECHNICAL MATHEMATICS

PRACTICAL ASSESSMENT TASK 1

GRADE 12

2023

TERM: 1
MARKS: 40
TIME: 3 hours

SURNAME AND NAME	
-------------------------	--

SCHOOL	
---------------	--

This task consists of 8 pages.

TECHNICAL MATHEMATICS TASK 1

TOPIC: DIFFERENTIAL CALCULUS

AIM:

- To apply differentiation in a real-life context

INSTRUCTIONS AND INFORMATION

1. The PAT Task 1 consists of TWO activities.
2. Do ALL the activities and answer ALL the questions.
3. Clearly show ALL calculations used in determining answers.
4. Materials required:
 - Pen
 - Pencil
 - Drawing instruments
 - Calculator
 - A 30 cm by 50 cm rectangular sheet of durable material for Activity 2(b) to make a rectangular cake box

ACTIVITY 1

AIM:

- To apply differentiation to maximise the area of a rectangular garden

Mr Khumalo wants to create a rectangular garden, similar to the picture shown below. The rectangle alongside the picture shows the top view of the rectangular garden. The perimeter of the garden should be 120 m. The material required to fence off the garden, excluding the gate, costs R250 per metre.

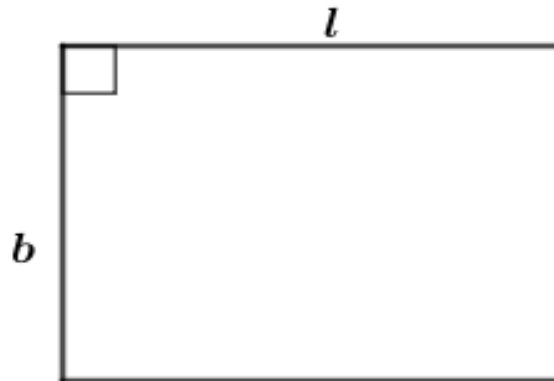
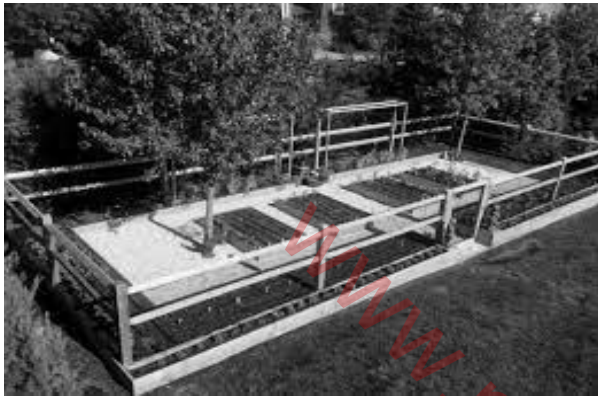

1.1 If the length (l) of a rectangular garden is x metres, express the breadth (b) in terms of x .

	Solution	Marks
		(2)

1.2 Write down the equation for the area, $A(x)$, of a rectangular garden in terms of x .

	Solution	Marks
		(1)

1.3 Hence, complete the table below.

Solution				Marks
Actual length (values of x)	Actual breadth	Area of rectangular garden	Diagram of a rectangular garden drawn to scale: 1 cm = 10 m	
10 m				
20 m				
30 m				
40 m				

(8)

1.4 Determine an expression for the rate of change of the area of a rectangular garden with respect to x .

	Solution	Marks
		(2)

1.5 Determine the value of x for which the area of a rectangular garden will be a maximum.

	Solution	Marks
		(2)

1.6 Hence, determine the maximum area of a rectangular garden.

	Solution	Marks
		(2)

1.7 Mr Khumalo has a budget of R30 000 to fence off the garden.

Determine if he will have sufficient funds to fence off the garden if it is further given that a gate of 1,2 m width, that costs R500, will be fitted on one side of the garden.

	Solution	Marks
		(4)

[21]

ACTIVITY 2

AIMS:

- To apply differentiation to maximise the volume of a rectangular prism
- To make an open cake box

A metal fabrication company manufactures cake boxes from rectangular metal sheets of dimensions 50 cm by 30 cm. The diagram below illustrates how equal squares are cut off from each corner of a metal sheet to make an open cake box, as shown in the picture alongside the diagram. The length of the sides of each of the cut-out squares is x cm.

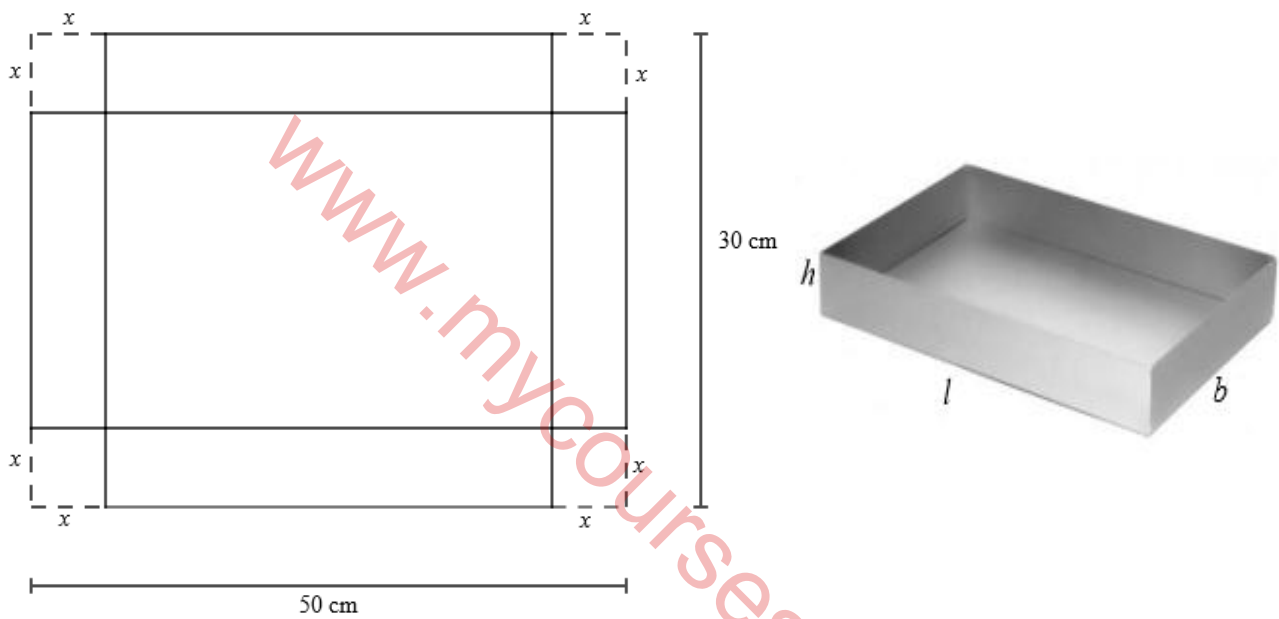

Activity 2(a)

2.1 Write down the dimensions, length (l), breadth (b) and height (h), of a cake box in terms of x .

	Solution	Marks
	$l = \dots\dots\dots$	
	$b = \dots\dots\dots$	
	$h = \dots\dots\dots$	
		(3)

2.2 Express the volume (V) of a cake box in terms of x :

	Solution	Marks
		(2)

2.3 Hence, determine, to the nearest centimetre, the dimensions of a cake box for which the volume will be a maximum.

	Solution	Marks
		(6)

2.4 Determine the maximum volume of a cake box.

	Solution	Marks
		(1)
		[12]

Activity 2(b)

This activity should be done in TWO days outside school hours.

Make a model of a cake box using a durable material based on calculations done in Activity 2.3.

NOTE: The model must be able to carry a rectangular-shaped cake with a mass of 1 kg without being distorted or damaged.

The following marking criteria will be used for assessing the model:

No.	Criteria	Marks
1	Accuracy of dimensions as per Activity 2.3	3
2	Durability of material used	2
3	Model design and presentation	2
	TOTAL	7

ASSESSMENT RUBRIC FOR MARKING ACTIVITY 2(b)					
CRITERIA	0 marks	1 mark	2 marks	3 marks	TOTAL
1. Accuracy of dimensions	None of the dimensions are correct.	Only 1 of the dimensions is correct.	Only 2 of the dimensions are correct.	All 3 dimensions are correct.	
2. Durability of material used		Model is not sturdy and there is distortion when 1 kg of rectangular-shaped cake is placed inside.	Model is very sturdy and there is no distortion when 1 kg of rectangular-shaped cake is placed inside.		
3. Model design and presentation		Model is satisfactorily designed and decorated but not all joints are smooth. There are one or more rough edges.	Model is very well designed, decorated and all joints are smooth with no rough edges.		
TOTAL					7

TOTAL: 40

NOTE TO TEACHER:

Ensure that the learner's model is carefully assessed and thereafter safely stored for the purposes of internal and external moderation. Furthermore, ensure the learner's full names and surname as well as the name of the school is indicated on the model.



basic education

Department:
Basic Education
REPUBLIC OF SOUTH AFRICA

TECHNICAL MATHEMATICS

PRACTICAL ASSESSMENT TASK 2

GRADE 12

2023

TERM: 2
MARKS: 30
TIME: 2 hours

SURNAMES AND NAMES OF GROUP MEMBERS	1.
	2.
	3.
	4.

SCHOOL	
---------------	--

This task consists of 8 pages.

TECHNICAL MATHEMATICS TASK 2

TOPIC: TRIGONOMETRY

AIM:

- To make and use a clinometer in determining the height of a building or object

ACTIVITY 1

- Learners must work in groups of FOUR to complete this activity.
- Learners should be given FIVE days for this activity and it should be done out of school hours to collect resources and make the clinometer before the writing of the PAT.

INTRODUCTION

- A clinometer, also known as an inclinometer, is a measuring device that could be used to measure an angle of elevation of a slope. The angle of elevation of a slope could be used, with the application of trigonometric principles, to calculate heights of tall objects.

INSTRUCTIONS AND INFORMATION

1. Use the internet or any other relevant source to search for information on how to make and use a clinometer.
2. List all the resources that are needed to make a clinometer. Use the space provided below.

Resources

--

3. Make a clinometer using information acquired from the internet or any other relevant source. Work in groups of FOUR.
4. Indicate learner's names in the clinometer.
5. Keep the clinometer safe. It should be made available for all levels of moderation.

ACTIVITY 2

- Keep the same groups as in ACTIVITY 1.
- Learners in their groups should work together and rotate responsibilities to do the following:
 - Reading instructions
 - Using clinometer
 - Taking measurements
 - Recording measurements

AIMS:**Learners are required to:**

- Measure the angle of elevation of the top of an object from three different points of observation
- Use a tape or metre wheel to measure the distance from each point of observation to the foot of an object
- Complete the table provided by drawing sketch diagrams and recording measurements

RESOURCES:

- Clinometer
- Measuring tape or metre wheel
- Record table

INSTRUCTIONS

1. Identify any object (e.g. building, tree, tower, flagpole, netball pole, cliff). The foot of the object must be on the same horizontal plane with the observation points, that all learners will determine the height of.
2. Identify different observation points from where the angles of elevation should be measured.
3. Use a clinometer to measure each angle of elevation (α) of the top of an identified object.
4. Use a tape or a metre wheel to measure a distance (ED) from the observation point to the foot of an identified object.
5. Use a tape to measure each height to eyes (AE), as shown in the picture below.
6. Record the measurements as required in the table on the next page.
7. Draw a sketch diagram for each scenario and label measurements in each case.
8. Complete the individual record table.

The picture below illustrates the scenario.

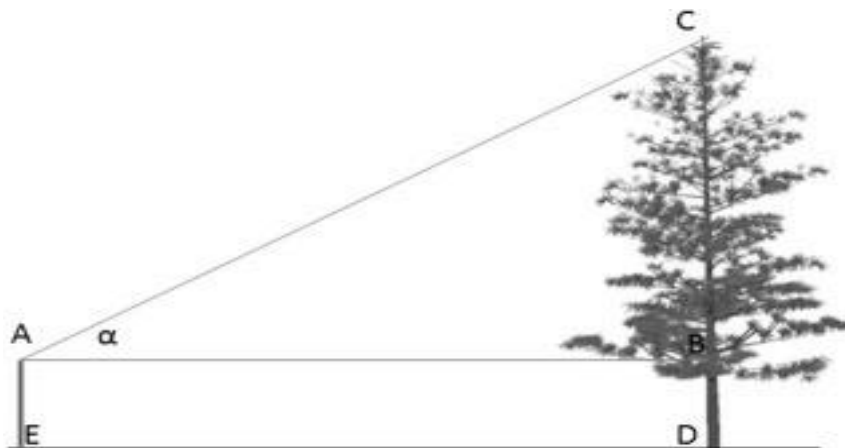

Observation point	Sketch diagram	Angle of elevation (α)	Distance from observer to the foot of an object (ED)	Distance from height to eyes (AE)
A				
B				
C				

ACTIVITY 3

AIM:

- Learners are required to calculate the height of an identified object from three observation points and finally give the height of an object.

RESOURCES:

- Record table

Use the information collected in the table above to calculate the height of an object from each observation. Use the space provided in the table below.

Observation point	Calculations for the height from three observation points
A	
B	
C	
Average height	

Conclusion:

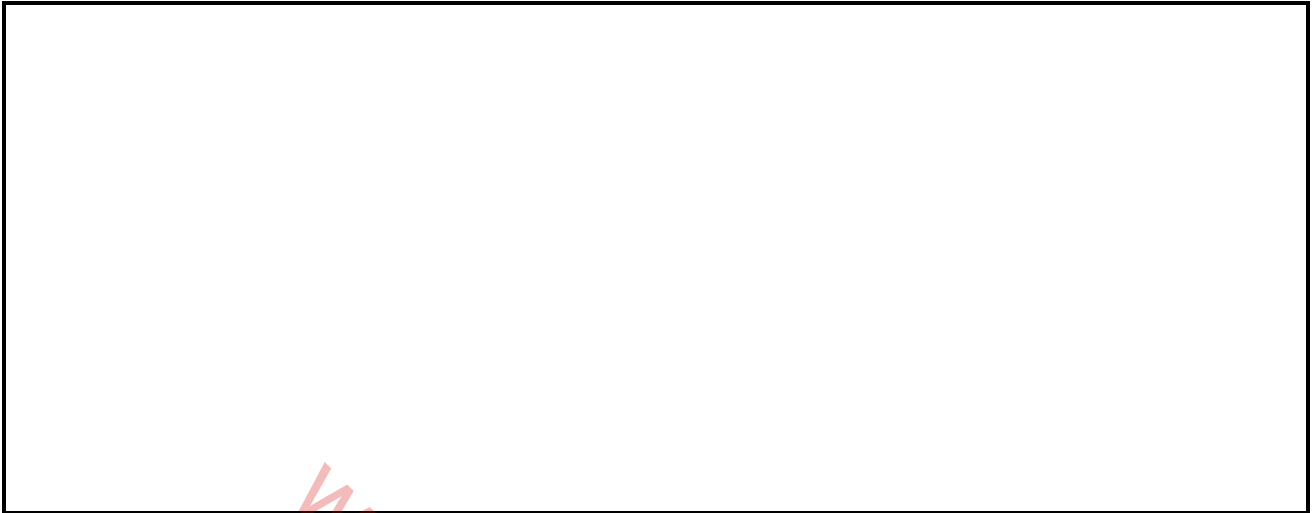

www.mycourses.co.za

ASSESSMENT RUBRIC FOR MARKING PAT 2					
LEARNER'S NAME & SURNAME:					
No.	Assessment criteria	Poor 1	Average 2	Good 3	Excellent 4
1.	Attitude	No motivation; always needed support to carry out instructions; clinometer was not neat and appealing	Little motivation; needed little support to carry out instructions; clinometer was fairly neat and appealing	Good motivation; needed no support to carry out instructions; clinometer was neat and appealing	Highly motivated; needed no support to carry out instructions; clinometer was very neat and appealing
2.	Values	Unable to work as a team; does not accept responsibilities; clinometer and a practical activity were not completed on time and unable to work independently	Able to work as a team; accepted responsibilities; clinometer and a practical activity were completed on time and able to work independently	Actively worked as a team; accepted responsibilities; clinometer and a practical activity were completed on time and able to work independently	Outstandingly worked as a team; voluntarily accepted responsibilities; clinometer and a practical activity were completed on due time and able to work independently
3.	Skills	Unable to list resources required to make a clinometer and did not complete a clinometer	Able to list some of the resources required to make a clinometer and partially completed a clinometer	Able to list most of the resources required to make a clinometer and fully completed a clinometer	Able to list all the resources required to make a clinometer and a clinometer was fully completed and immaculate
		Unable to use a clinometer and could not measure angle of elevation	Able to use a clinometer and could measure angle of elevation	Able to use clinometer and could accurately measure angle of elevation	
		Could not accurately use a tape to measure a distance from an observer to the foot of an object in all the scenarios	Could accurately use a tape and partially measured a distance from an observer to the foot of an object in the scenarios	Could accurately use a tape to measure a distance from an observer to the foot of an object in most of the scenarios	Could accurately use a tape to measure a distance from an observer to the foot of an object in all of the scenarios
		Could measure the distances in all the scenarios but not accurately	Could partially measure the distance in the scenarios accurately	Could measure distance in most scenarios accurately	Could measure distance in all scenarios accurately
		Could not completely record, draw and label measurements in each diagram	Could completely record, draw and label measurements in each diagram	Could completely and correctly record, draw and label measurements in each diagram	

4.	Knowledge and reasoning	Calculations made were not based on the measurements recorded and the formula used was incorrect	Calculations made were based on the recorded measurements; formula used was correct; a few errors were made on calculations	Calculations were based on the recorded measurements; formula used was correct; most of the calculations were correct	All calculations were based on the recorded measurements; formula used was correct; all the calculations were spot on with detailed steps
		Calculation of average height was incorrectly done; conclusion was not based on the calculated average	Calculation of average height was based on the heights calculated; conclusion was inconsistent with the calculated average	Calculation of average height was correctly done based on the heights calculated; conclusion was consistently made based on the calculated average	Calculation of average height was correctly done based on the heights; all calculations include relevant steps; conclusion was perfectly made based on the calculated average with much detailed explanation
TOTAL					/30

TOTAL: 30



basic education

Department:
Basic Education
REPUBLIC OF SOUTH AFRICA

TECHNICAL MATHEMATICS

PRACTICAL ASSESSMENT TASK 3

GRADE 12

2023

TERM: 3

MARKS: 30

TIME: 2 hours

SURNAME AND NAME	
-------------------------	--

SCHOOL	
---------------	--

This task consists of 7 pages.

TECHNICAL MATHEMATICS TASK 3

TOPIC: EUCLIDEAN GEOMETRY

AIMS:

- To apply the similarity theorem to determine the height of a tree when one height is known

INSTRUCTIONS AND INFORMATION

1. Follow instructions in ALL the questions.
2. Clearly show ALL calculations, diagrams, etc. that you have used in determining your answers.
3. Sketch diagrams need to be neat and labelled correctly.

www.mycourses.co.za

ACTIVITY 1

- This activity could be done in groups of FOUR learners and rotating responsibilities with:
 - One learner standing in a shadow
 - One reading instructions and recording measurements
 - The remaining two learners measuring lengths

AIMS:

Learners are required to:

- **Measure the height of each learner standing in a shadow**
- **Use a tape to measure the length of the shadow of a learner standing in the shadow and the length of the shadow of a tree**
- **Complete the table provided by drawing, labelling the sketch diagrams and recording measurements**

INTRODUCTION

The similarity theorem is very useful to determine the heights of very tall objects and lengths which are difficult to measure. Typical examples are the heights of buildings, trees, poles and towers and the widths of rivers.

RESOURCES:

- Measuring tape
- Record table

INSTRUCTIONS

1. Identify any vertical tree, standing on horizontal ground, that all learners will determine the height of.
2. A learner should stand in the shadow of a tree such that his/her shadow has the same end point as that of an identified tree. The picture on the next page illustrates the scenario.
3. Use the tape to measure the length of the shadow of a tree and the shadow of a learner.
4. Use the tape to measure the height of each learner.
5. Repeat the previous two activities with two or more learners of different heights; extra space is provided in case learners need to repeat this activity four times.
6. Draw sketch diagrams and label vertices and measurement in each case.
7. Record the measurements as required in the table provided on the next page.
8. Complete an individual record table.

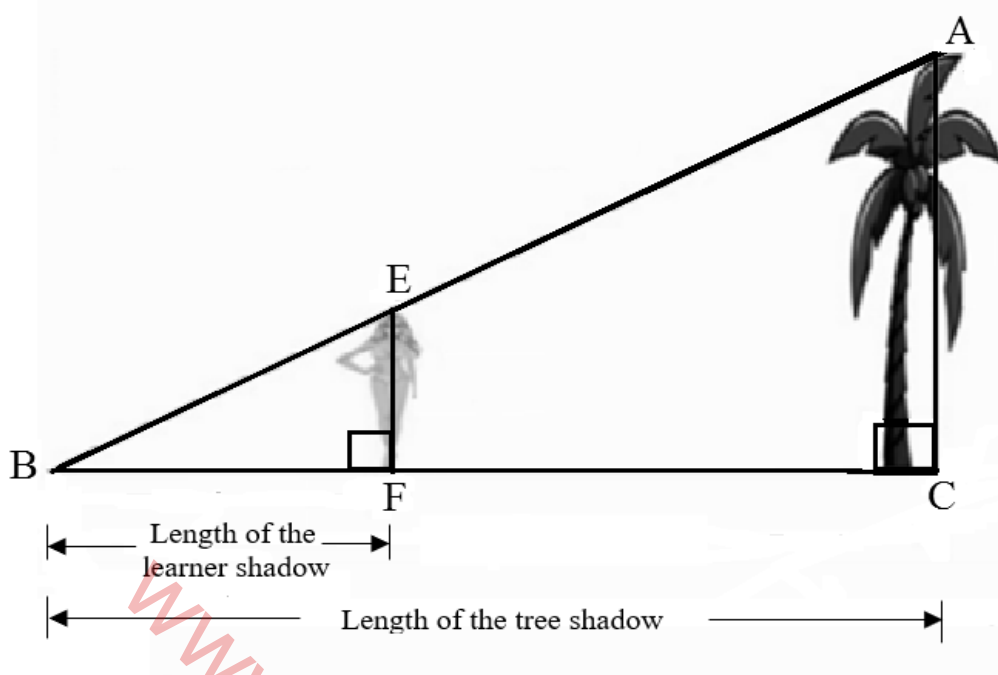

Complete the following table according to given instructions:

LEARNER	SKETCH DIAGRAM	LEARNER'S HEIGHT EF	SHADOW OF TREE BC	SHADOW OF LEARNER BF
1				
2				
3				

ASSESSMENT RUBRIC FOR MARKING ACTIVITY 1					
LEARNER'S NAME & SURNAME:					
No.	Assessment Criteria	Poor 1	Average 2	Good 3	Excellent 4
1.	Attitude	No motivation; always needed support to carry out instructions	Little motivation; needed little support to carry out instructions	Good motivation; needed no support to carry out instructions	Highly motivated; needed no support to carry out instructions
2.	Values	Unable to work as a team; does not accept responsibilities; a practical activity was not completed on time and unable to work independently	Able to work as a team; accepted responsibilities; a practical activity was completed on time and able to work independently	Actively worked as a team; accepted responsibilities; a practical activity was completed on time and able to work independently	Outstandingly worked as a team; voluntarily accepted responsibilities; a practical activity was completed on due time and able to work independently
3.	Skills	Could not accurately use a tape to measure the lengths of the shadows and the height of each learner in all the scenarios	Could accurately use a tape to measure the lengths of the shadows and the height of each learner in some of the three scenarios	Could accurately use a tape to measure the lengths of the shadows and the height of each learner in most of the scenarios	Could accurately use a tape to measure the lengths of the shadows and the height of each learner in all of the scenarios
		Could partially complete and correctly record measurements correct to two decimal places, draw and label vertices and measurements in each diagram	Could at most complete and correctly record measurements correct to two decimal places, draw and label vertices and measurements in each diagram	Could complete and correctly record measurements correct to two decimal places, draw and label all the vertices and measurements in each diagram	
TOTAL					/15

ACTIVITY 2

AIM:

- Learners are required to calculate the height of an object using information from the table in Activity 1 above.

INSTRUCTIONS

- This activity should be done INDIVIDUALLY in the classroom.
- Use the information collected in Activity 1 to answer the following questions.
 - Write down TWO reasons for triangles to be similar.

	Solution	Marks
		(2)

- Prove that two triangles are similar.

	Solution	Marks
		(3)

- Calculate, with reasons, the height, AC, using the information in each of the scenarios in Activity 1.

2.3.1		(3)
2.3.2		(2)

2.3.3		(2)
2.3.4	Average height	(2)
2.3.5	Conclude by giving the height of the tree.	(1)
		[15]

TOTAL: 30