

GRADE 1

Mathematics

Teacher Toolkit:
CAPS Aligned Lesson Plans

TERM 1

A MESSAGE FROM THE NECT

NATIONAL EDUCATION COLLABORATION TRUST (NECT)

Dear Teachers

This learning programme and training is provided by the National Education Collaboration Trust (NECT) on behalf of the Department of Basic Education (DBE)! We hope that this programme provides you with additional skills, methodologies and content knowledge that you can use to teach your learners more effectively.

What is NECT?

In 2012 our government launched the National Development Plan (NDP) as a way to eliminate poverty and reduce inequality by the year 2030. Improving education is an important goal in the NDP which states that 90% of learners will pass Maths, Science and languages with at least 50% by 2030. This is a very ambitious goal for the DBE to achieve on its own, so the NECT was established in 2015 to assist in improving education.

The NECT has successfully brought together groups of people interested in education so that we can work collaboratively to improve education. These groups include the teacher unions, businesses, religious groups, trusts, foundations and NGOs.

What are the learning programmes?

One of the programmes that the NECT implements on behalf of the DBE is the 'District Development Programme'. This programme works directly with district officials, principals, teachers, parents and learners; you are all part of this programme!

The programme began in 2015 with a small group of schools called the Fresh Start Schools (FSS). The FSS helped the DBE trial the NECT Maths, Science and language learning programmes so that they could be improved and used by many more teachers. NECT has already begun this scale-up process in its Provincialisation Programme. The FSS teachers remain part of the programme, and we encourage them to mentor and share their experience with other teachers.

Teachers with more experience using the learning programmes will deepen their knowledge and understanding, while some teachers will be experiencing the learning programmes for the first time.

Let's work together constructively in the spirit of collaboration so that we can help South Africa eliminate poverty and improve education!

www.nect.org.za

CONTENTS

About the Lesson Plans and Resources	3
Lesson Plan Outline	6
Week 1: Revision Lesson Activities	9
Week 2	18
Lesson 1: Zero and one	18
Lesson 2: The number 2	21
Lesson 3: The number 3	24
Lesson 4: Compare and order numbers 1 to 3	27
Week 3	30
Lesson 5: The number 4	30
Lesson 6: The number 5	33
Lesson 7: Numbers 1 to 5	36
Lesson 8: Addition up to 4	39
Week 4	42
Lesson 9: Addition up to 5	42
Lesson 10: Counting on – add up to 5	45
Lesson 11: Breaking down and building up numbers to 5	48
Lesson 12: Addition doubles – 1 to 5	51
Week 5	54
Lesson 13: Addition up to 5	54
Lesson 14: Subtraction up to 4	57
Lesson 15: Subtraction up to 5	60
Lesson 16: Counting back – subtract up to 5	63
Week 6	66
Lesson 17: Add and subtract – number bonds and family facts	66
Lesson 18: Numbers 6 to 10 – recognition	69
Lesson 19: Number patterns to 10	72
Lesson 20: Numbers 11 to 15 – recognition	75
Week 7	78
Lesson 21: Patterns of 10	78
Lesson 22: Numbers 16 to 20 – recognition	81
Lesson 23: Number patterns to 1 to 15	84
Lesson 24: 3-D – balls and boxes	87

Week 8	90
Lesson 25: Size of 3-D objects	90
Lesson 26: 3-D – building objects	93
Lesson 27: Length	96
Lesson 28: Length	99
Week 9	102
Lesson 29: Geometric patterns	102
Lesson 30: Data – sort objects	105
Lesson 31: Data – sort objects	108
Lesson 32: Mass	111
Week 10	114
Lesson 33: Mass – heavy and light	114
Lesson 34: Capacity	117
Lesson 35: Position	120
Lesson 36: Position – follow directions	123
Week 11	126
Lesson 37: Grouping	126
Lesson 38: Sharing	129
Lesson 39: Passing time	132
Lesson 40: Telling time	135

ABOUT THE LESSON PLANS AND RESOURCES

The lesson plans and resources in this book are part of the Teacher Toolkit for Mathematics Grade 1 Term 1. The other documents in the toolkit are:

- a CAPS Aligned Planner, Tracker and Assessment Resources

A variety of printable resources that you can copy for yourself and/or your learners are included at the end of the lesson plans in this book. They include:

- Resource sheets:** These comprise a variety of teaching and learning aids that are needed in certain lessons. The specific resource sheet, and the number of copies needed, is noted in the relevant lesson plan and in the tracker so that you can prepare them in advance.
- Mental mathematics challenge cards:** A pack of eight mental mathematics challenge cards (solutions are provided) are included to allow for routine weekly mental mathematics activities that you can record.
- Enrichment activity cards:** A pack of 32 enrichment activity cards (solutions are provided) are included for learners who complete the day's classwork activities ahead of the class.

A. About the lesson plans

The lesson plans give detailed information about how to teach a CAPS-aligned lesson every day. By following the lesson plans, you will ensure that you cover the content and assessment tasks specified in the curriculum and give your learners the best possible chance of developing the knowledge and skills required for Mathematics in this grade.

1. Curriculum alignment

The lessons are sequenced according to the topics in the CAPS and weighted according to requirements given there, and the programme of assessment is accommodated. Every lesson shows the CAPS content and skill being focussed on in the lesson.

2. Links to the DBE workbooks

Links are given in the lessons to all appropriate DBE worksheets. Note that the pages referred to are all from the 2017 edition of the DBE workbook. This changes very little from year to year, but if you use a different edition of the workbook, you should check that the worksheet on the same page in this different edition is still appropriate for your purpose.

Bilingual learner material is provided in the LoLT of the school in accordance with the Foundation Phase language policy.

3. Broad overview of the content of the lesson plans

Each lesson plan provides a set of steps to guide you in delivering the lesson. In addition, it contains learner activities that will help learners develop the concepts and skills set for the lesson. These include the required daily mental mathematics activity, whole class oral activities led by the teacher, classwork and homework activities, as well as answers for these. All the classwork and homework activities are given in the lesson plans, learners must either copy these into their books or teachers can photocopy the activity.

4. Assessment

The programme of assessment suggested in the lesson plans and tracker is adaptable and can be adjusted to comply with the CAPS as amended by Circular S1 of 2017 and provincial responses to this. The lesson plans and tracker provide a number of resources to support both formal and informal assessment in this programme, as noted below:

- Oral and practical activities which you can use to assess learners as you observe and interact with them in class are provided in the tracker. Rubrics and checklists with criteria for this assessment are provided in the tracker, at the end of the table for

the week in which the assessment is suggested.

- There is an item bank of written assessment questions, with marking memos in the tracker. Items that are relevant to a specific lesson are noted in the resources column for the lesson in the tracker.
- A complete overview of the programme of assessment for the term is given in the tracker. This shows you when it is suggested you carry out both formal (and informal) assessment tasks which are oral, practical and written. This will assist you in planning and monitoring your assessment programme.
- There is also recommended mark record sheet in the tracker. This has been drawn up to assist you as you record your marks on SA SAMS.

5. *Managing the lesson programme*

A set of orientation activities on eight different topics aligned with the CAPS baseline assessment requirements is provided for the start of the term. You should use all or a selection of these activities in the first week of term before the formal teaching of the numbered lesson plans begins.

The formal curriculum for Term 1 of Grade 1 is covered in a set of 40 numbered, fully developed lesson plans, paced to cover a 50-day teaching term. There are four such lesson plans each week for ten weeks of the term. There is no formal numbered lesson plan for the fifth lesson each week; instead, it is assigned for you to use for a variety of purposes. You can use this time to catch up, remediate or consolidate the content covered in the week's formal lessons. Learners can complete the worksheets from the DBE workbook related to topics taught in the week if they did not manage to do them in the course of the week.

Each lesson is designed to last 90 minutes. If your school's timetable has different period lengths, you will have to adjust the amount of work done in each lesson to accommodate this. However, each school should allow seven hours for Mathematics each week, and it should be possible to fit in all the work for the week, even if the lengths of periods are not the same as in the lesson plans.

6. *Sequence adherence and pacing*

Each lesson and its contents have been carefully

sequenced. It is therefore important that lessons are not skipped. Should you miss a Mathematics lesson for any reason, you should continue the next day from where you last left off. Do not leave a lesson out. You may need to speed up the pace of delivery to catch up a missed lesson by covering the lesson concept content of two consecutive days in one day. To do this you could cut out or cut back on some of the routine activities like mental mathematics or homework reflection to save time until you are back on track with the expected delivery of the plans. You need to prepare very well as this will help you to manage the full set of lessons at the appropriate pace.

7. *Lesson preparation*

The lesson plans provide a detailed lesson design for you to follow. However, to deliver the lessons successfully **you must do the necessary preparation yourself**. The information below outlines some key aspects of preparation.

- a) **Term focus:** Start by looking at the CAPS document and **orientating** yourself to the CAPS content focus for the term. It is important that you are clear about the content focus, as this will frame everything you do in your Mathematics lessons during the term.
- b) **Prepare resources:** The resources needed for each lesson are listed in each lesson plan and in the tracker. It is very important that you check what is required for each lesson ahead of time, so that you have all your resources ready for use every day (e.g. counters, number boards, paper cut-outs, examples of shapes, etc.).
 - **Your lessons will not succeed if you have not prepared properly for them.**
 - If you do not have all the necessary resources readily available, see how best you can improvise, e.g. get learners to collect bottle tops or small stones to be used for counting, or make your own flard cards/number boards using pieces of cardboard and a marker pen.
 - Collect empty cool drink cans, cereal boxes, washing powder boxes, plastic bottles, etc. for the **shop activity** in the week long in advance, so that you have all the necessary goods to stock your shop.
 - Use newspapers and magazines to cut out pictures that could be used in your teaching. If you have access to the Internet, search for and

print out pictures that you may need to use as illustrations in your lessons.

c) **Prepare for the written classwork and homework activities:**

When preparing your lessons, check the lesson activity requirements. In some instances you will need to write information or draw some diagrams on the board that you will use while you do the interactive whole-class-teaching component of the lesson. Also mark the homework activities as often as you can, so that you can give useful feedback to the learners each day, and be aware of any difficulties learners are having as soon as they become apparent.

d) **Prepare to teach the concepts and skills associated with the lesson topic:**

Think carefully about what it is that you will teach your learners in the lesson. Prepare a short introduction to the topic, so that you can explain it in simple terms to your learners. Make sure you have prepared for the teaching of the concepts before you teach – you need to be able to explain new Mathematics content and skills to the learners. Be sure you have gone through the oral teaching activities provided in the lesson plans. Also make sure that you have thought about how to use the resources in the lesson effectively. This preparation needs to be done in advance, so that you do not waste time during the lesson. Be sure you are familiar with the sequence of activities in the lesson plan. Prepare yourself to assist learners with any questions they might have during the lesson. Also give some thought to how you will accommodate learners with barriers to learning.

e) **Lesson pace:** Think about how much time you will spend on each activity. It is important to plan how you will manage the pace of the lesson carefully; otherwise you will not manage to cover all the lesson content. Not all learners work at the same pace. You need to determine the pace – be guided by the average learner and the recommendations in the lesson plans. Be careful

not to slow down to the pace of the slowest learners as this will disadvantage the other learners.

f) **Organisation of learners:** Think about how you will organise learners when they do the classwork activities. Will they work alone, in pairs or in small groups? How will you organise the pairs or groups if you choose to use them? You need to organise the learners quickly at the beginning of the lesson, so that you do not waste too much time on this.

g) **Inclusive education:** Consider the needs of any learners with barriers to learning in your class, and how best you can support them. The DBE has published some excellent materials to support you in working with learners with learning barriers. Two such publications are:

- Directorate Inclusive Education, Department of Basic Education (2011) *Guidelines for Responding to Learner Diversity in the Classroom Through Curriculum and Assessment Policy Statements*. Pretoria. www.education.gov.za, www.thutong.doe.gov.za/InclusiveEducation.
- Directorate Inclusive Education, Department of Basic Education (2010) *Guidelines for Inclusive Teaching and Learning. Education White Paper 6. Special needs education: Building an inclusive education and training system*. Pretoria. www.education.gov.za, www.thutong.doe.gov.za/InclusiveEducation.

LESSON PLAN OUTLINE

Lesson Plan Outline	
<p>Each lesson plan has several components. Information about each is given in the table below. This information tells you how to use each of the components of the lesson plans and how they fit together to create a well-paced and properly scaffolded Mathematics lesson each day. You need to read this outline as you prepare each lesson until you are fully familiar with the general lesson plan components, pace and structure.</p>	
Lesson topic	Each lesson has a topic with specific detail about the day's lesson.
CAPS topics	The CAPS content related to the day's lesson is given here, together with the reference number for this content in the expansion of content section in the CAPS document for this term. You are encouraged to look at the CAPS to read about the selected curricular topics for the day.
Lesson vocabulary	A list of all mathematical terms used in the lesson is given here. Go through the lesson vocabulary each day as you prepare for the lesson. These terms are important, as they are the language of Mathematics that each learner needs to learn and understand in order to build a solid foundation and understanding of this subject. It is important to explain these words to your learners and to practise using them with your learners during the lesson.
Prior knowledge	<p>The prior knowledge section gives information about content that learners should have learnt in earlier grades that will be built on in this lesson.</p> <ul style="list-style-type: none"> You need to read through this section when you do your lesson preparation. No time is allocated to this part of the plan because it does not form part of the teaching of the day's lesson. The information about prior knowledge may help you to assist learners who struggle to understand the content of the lesson because there are gaps in the prior knowledge on which the lesson is based. You can use the information about prior knowledge to help you identify such gaps and to diagnose learners' needs in relation to content they do not yet know that may be preventing them from understanding the day's lesson. Remediation may be needed on prior knowledge that you notice is not properly in place.
Assessment	<p>A reminder to refer to the tracker for the formal oral, practical or written assessment activity for the day is given here.</p> <ul style="list-style-type: none"> On-going formal oral and practical assessment should be done virtually every day in your class. This means you will record a mark for a few learners for a certain criterion from the curriculum each day. Decide how many learners to assess every day, so that you assess your whole class in the time allocated to each assessment activity. Rubrics and checklists to guide you in giving ratings for the oral and practical assessments are given in the tracker at the end of the tracker table for each week. Each day you need to use the appropriate rubric or checklist for the assessment activity of that day. Written test items and their memos are provided in the tracker. Links to these items are given in the resources column of the tracker to show you in which lesson they should best be used. A <i>Suggested Assessment Record Sheet</i> that you can use to record your term marks is given in the tracker. This sheet aligns with the SA SAMS.
Remediation	<p>Optional as required. You could use these activities to assist slower learners. You need to decide, based on your observation of the learners while you are teaching the lesson content, whether to use this content and with which learners. It will be done with a smaller group of learners/individual learners while the rest of the class is working through the Classwork activity.</p>

Lesson Plan Outline

Enrichment	<p>Optional as required. You could use these activities as extra work for fast learners or others interested in doing them.</p> <p>Activities that you can use for enrichment opportunities for learners who have completed the lesson activities are provided in a set of enrichment activity cards at the end of the lesson plan set. Ideally, you should photocopy the enrichment cards, paste them onto cardboard and laminate them, so that they can be used as a resource, not only this year, but in the future as well.</p> <p>Learners should work on these cards independently or with their peers who have also completed the classwork. They may work through the cards in any order. You may need to explain some of the activities to the learners who use them. You should tell them to ask questions if they have any.</p> <p>All learners who show an interest in the enrichment activities should be encouraged to work through the cards.</p>
Mental mathematics (15 minutes)	<p>This is the first component of the lesson. We recommend that you take at most 15 minutes to do the mental mathematics activity. There are two parts to the mental mathematics activity, a counting activity and a set of questions to drill recall and basic mathematical strategies.</p> <p>Mental mathematics is not a concrete activity (as the title suggests). However, if there are learners who need concrete aids to complete the mental mathematics activities, we suggest that you allow them to use their fingers to count on.</p> <ul style="list-style-type: none"> • Observe which learners struggle with mental activities, and make sure you spend time to assist them to reach the required level of competence by offering remediation activities using concrete aids. • The answers to the ten mental mathematics questions are given in the answer column in the lesson plans. • It would be far better to do all ten questions per day, but if you find that your learners struggle to finish these in ten minutes, do a minimum of five questions. <p>There is a set of mental mathematics challenge cards at the end of the lesson plans. Learners write the answers to the questions given on these cards. We recommend that learners only do written mental mathematics once a week and oral mental mathematics on all the other days. You can use this work to obtain a mental mathematics activity mark each week.</p>
Correction/reflection on homework (15 minutes)	<p>This is the second component of the lesson. We recommend that you take 15 minutes to remediate and correct the previous day's homework. Read out answers to all of the homework questions. Let learners/peers mark the work. Also try to check homework yourself as often as you can.</p> <p>Choose one or two activities that you realise were problematic to work through in full with the whole class. In this part of the lesson you may reflect on the previous day's work. Allow learners the opportunity to write corrections as needed.</p>
Lesson content – concept development (30 minutes)	<p>This is the third component of the lesson. It is the body of the lesson, in which learners are introduced to the new work planned for the day. We recommend that you actively teach your class for 30 minutes – going through the activities interactively with your learners.</p> <ul style="list-style-type: none"> • Activities on the content that you will teach with worked examples and suggested explanations are given. These activities have been carefully sequenced and scaffolded so that they support the teaching of the concepts for the day. You should work through each of these with your class. • It is important to manage the pace of the lesson carefully, otherwise you will not manage to cover all the lesson content. Once you have introduced the new concept, work through Activity 1 of the lesson with the whole class (or with learners in groups). Then immediately move on to the next activity, and provide a reasonable time for the learners to complete Activity 2, but do not wait for the last learner to finish before moving on. If there are further activities, continue pacing yourself in this way, so that you work through all of the activities in each lesson. A few activities are marked as <i>optional</i> – these need only be done if you have sufficient time.

Lesson Plan Outline

Classwork activity (25 minutes)	<p>This is the fourth component of the lesson. We recommend that you allocate 25 minutes to classwork. You could go over one or two of the classwork activities orally with the whole class before allowing the class to complete the activities independently (individually or in groups).</p> <ul style="list-style-type: none">• Learners do most of the activities in their Mathematics books (an exercise book for learner Mathematics writing activities). Some activities are done in the DBE workbook.• You should allow the learners opportunities to do these activities alone, in pairs and in groups so that they experience working alone as well as with their peers.• Wrap up the lesson each day by giving the learners the answers to the classwork, and allow time for corrections to be written if and when necessary.
Homework activity (5 minutes)	<p>This is the fifth and final component of the lesson. We have allocated five minutes to give you time to tell the learners about the homework each day. Here you find a set of activities on the day's content that you can set for your class to do for homework. This is to consolidate the Mathematics that you have taught them that day. Homework also promotes learner writing and development of their mathematical knowledge.</p>
Reflection	<p>Each day there is a reminder to note your thoughts about the day's lesson. You will use these notes as you plan and prepare for your teaching.</p>

WEEK 1: REVISION LESSON ACTIVITIES

The lesson activities given below are for you to use on the first few days of school when the learners are still settling down and you are not quite ready to start the formal CAPS lesson plans that follow. These revision lesson activities will help you to keep learners occupied in a meaningful way at the beginning of the term and to make observation notes on their mathematical knowledge development. The observation notes that you make will inform your intervention strategies. It will also help you get to know the learners.

Activities are provided relating to eight CAPS topics. You do not need to use all of these activities.

- Choose the ones that you think would be best for your learners to work on in order to revise/recap on work done in the previous year.
- You can do it in the order of your choice.
- For some of the activities you need to work with your learners interactively while learners can do the others independently or in groups.

Keep a notebook where you write your observations on learners' knowledge.

The CAPS baseline framework

Criteria: Can the learner	Yes	No
Count objects to 10		
Recognise, identify and read the number symbols from 1 to 10		
Compare objects up to 10 using more or less		
Sort objects according to one attribute		
Copy a pattern		
Describe position		
Follow directions		
Use ordinal numbers to show order, place and position		
Describe 3-dimensional objects according to size		
Use appropriate language to talk about length		
Use appropriate language to talk about mass		
Compare numbers up to 10 using equal to		
Orally add objects up to 10		

Topic 1: Number concept

Concepts and skills for today

- Count objects up to **5**.
- Compare objects up to **10** using **more, less, equal to**.
- Read number symbol **1**.

Warm-up activity

Give the learners the opportunity to familiarise themselves with the Mathematics teaching and learning resources in your classroom by letting them play with some of them for about ten minutes in their groups. These may include:

- Counting manipulatives such as counters, stones, etc.
- Space and shape manipulatives such as shapes, blocks, cubes, etc.

After learners have played with the manipulatives in their groups, call them to attention as a class to revise number names and number concept: Try to call on individual learners to answer your questions – although at times more than one might answer.

- Hold up your hands – empty. Ask: **How many counters do I have in my hand?** (0, or none, or no counters)
- Hold up 1 counter. Ask: **How many counters do I have in my hand?** (1)
- Hold up 2 counters. Ask: **How many counters do I have in my hand?** (2)
- Continue in order up to 5 counters.
- Now hold up different numbers of counters (between 0, 1 and 5) asking each time how many counters you have in your hand.

Spend five minutes with your learners packing the learning resources away. Ask the learners why they think we should pack the learning resources away neatly and look after them well. Discuss. It is important to develop the responsibility of learners from an early age.

Activities

Give learners the following activities using concrete resources that you give to them and ask learners to give you oral explanations of what they did.

Activity	Can the learners	Observation
1. Let learners count out real objects up to 5 , e.g. stones, flowers, counters, etc.	<ul style="list-style-type: none">• Count objects up to 5?	
2. Ask one learner to show you 4 counters. Ask another learner to show you 4 counters. Ask: Who has more counters? Who has less counters? Do you have the same number of counters? Yes. The number I have is equal to the number s/he has. (Repeat with different learners and different numbers of counters.)	<ul style="list-style-type: none">• Compare objects up to 10 using more, less, equal to?	
3. Show the learners the number 1 picture card. Ask: What is the number symbol on the card?	<ul style="list-style-type: none">• Read the number symbol 1?	

Topic 2: Sorting shapes and patterns

Concepts and skills for today

- Count objects up to **5** and read the number symbol **2**.
- Sort objects according to one attribute (shapes). Note that they do not have to give you the shape names.
- Copy a pattern.

Warm-up activity

First, give the learners ten minutes to cut pictures from old magazines and newspapers with a pair of scissors. Help learners to hold the scissors and to cut in a straight line. After that let them cut up the paper freely in any way. Secondly, spend five minutes with your learners showing them how to hold a pair of scissors when giving them to another person (pass scissors from person to person). (If you do not have enough pairs of scissors for this Classwork activity you could prepare some cut-outs from old magazines for the groups to use in the following activity.)

In groups, allow the learners to sort the shapes that they have cut into categories of their choice. They might choose types of shape, colour, number, etc. Once they have finished their sorting, ask questions such as:

- **What did you chose to guide your sorting?** (Answers will vary)
- **How many (cars) did you find?** (cars/other categories chosen for sorting – learners give the numbers they found)
- **Is there another way you could sort your group’s cut-outs? If so, how?**

Be sure to ask each group at least one question and try to allow as many as possible individual learners to respond.

Activities

Give learners the DBE workbooks. Briefly discuss with them how to take care of a book. This follows on the discussion on responsibility.

Activity	Can the learners	Observation
1. Ask the learners to count the animals on DBE worksheet 5 (the first page only, p. 10).	<ul style="list-style-type: none">• Count objects up to 5?	
2. Ask the learners to find the cut-out circles, squares, triangles and diamonds at the back of the DBE workbook and put (not paste) them into the spaces (DBE worksheet 4, pp. 8 and 9).	<ul style="list-style-type: none">• Sort objects according to one attribute (shape)?	
3. Draw a pattern: circle, square, circle, square on the board and ask learners to use the shapes in the above activity to copy the pattern.	<ul style="list-style-type: none">• Copy a pattern?	
4. Show the learners the number 2 picture card. Ask: What is the number symbol on the card?	<ul style="list-style-type: none">• Read the number symbol 2?	

Topic 3: More or less

Concepts and skills for today

- Count objects up to **10**.
- Compare given objects using words such as **more** or **less**, **fewer than** and **more than**.
- Copy a pattern.
- Read the number symbol **3**.

Warm-up activity

Learners have been working with their DBE workbooks in previous lessons. Revise for ten minutes with the learners how we should look after a book, how we page through it, and where to find the worksheet number. Note that if the number is higher than the numbers they can read, you need to support the learners. You can use the worksheet numbers on a daily basis for number recognition. Spend five minutes discussing why we should look after our books.

Give each group of learners 10 counters. Allow learners to help you count out the correct number – while they are doing this they demonstrate their ability to count to ten. Once each group has 10 counters, call on pairs of groups to count out different numbers of counters in order to compare the numbers they have counted by asking the following questions:

- Ask one group to count out 4 counters and put them forward on their desk. Ask another group to count out 3 counters. Ask:
 - **Which group has more counters?**
 - **Which group has less counters?**
 - **Did group X count out more than group Y?**
 - **Did group X count out fewer than group Y?**
- Repeat these questions referring to different numbers in the number range 0–5 and by allowing different groups to count out. Extend the number range if you think you could challenge the learners without going beyond the general capacity of the learners.

Activities

Note how the learners count objects when they do these activities. Do they use their fingers to point?

Activity	Can the learners	Observation
1. Go to DBE worksheet 5 (p. 10). Ask learners to count the animals.	<ul style="list-style-type: none">• Count objects up to 10?	
2. Ask the learners to look at the snails. Ask: How many snails? Point to the dogs. Ask: How many dogs? Ask: Which is more? Which is less? How do you know? Do the same with less, comparing different groups of shapes.	<ul style="list-style-type: none">• Compare objects using the words more or less?	
4. Show the learners the number 3 picture card. Ask: What is the number symbol on the card?	<ul style="list-style-type: none">• Read the number symbol 3?	

Topic 4: Sort colours

Concepts and skills for today

- Count objects up to **10**.
- Compare given objects using words such as **more** or **less**.
- Sort objects according to one attribute (colour).
- Read the number symbol **4**.

Warm-up activity

Revise the primary colours (red, blue and yellow) with your learners. Ask learners to point out some red objects in the class, then some that are blue and some yellow. Count the numbers of red, blue and yellow shapes that you can see in the class. (Prepare the class before this activity if necessary by putting some different coloured objects in clearly visible positions.)

Write the number of each category of shapes on the board (e.g. Red = 3; Blue = 4; Yellow = 5). Ask the class questions such as the following:

- **Are there more red shapes than yellow shapes?**
- **Are there less red shapes than yellow shapes?**
- *Repeat similar questions using other colour combinations.*

Now go to DBE worksheet 8 and ask learners to show you the red, blue and yellow objects. What other colour can you also see on this page? (Green)

Activities

Note how the learners count objects when they do these activities. Do they use their fingers to point?

Activity	Can the learners	Observation
1. Go to DBE worksheet 8 (p. 17). Ask learners to show you the red paint. Ask them how many red objects there are. Do the same with blue, green and yellow .	<ul style="list-style-type: none">• Count objects up to 10?	
2. Look at the blue paint. Are there more or less objects that are blue than not blue .	<ul style="list-style-type: none">• Compare objects using the words more or less?	
3. Show the learners the number 4 picture card. Ask: What is the number symbol on the card?	<ul style="list-style-type: none">• Read the number symbol 4?	

Topic 5: Position and direction

Concepts and skills for today

- Describe position.
- Use ordinal numbers to show order, place or position.
- Follow directions.
- Read the number symbol **5**.

Warm-up activity

Ask the learners if they like playing games. Discuss. Tell learners that they are going to play a game outside. Explain to the learners that there are rules that must be followed when they go outside to play games.

Explain to the learners how to play *Simon says*. Take the class outside to an open space. Play *Simon says* using words such as *on top of*, *in front of*, *behind*, *left*, *right*, *up*, *down* and *next to*. Give instructions such as:

- **Jabu please go and stand next to Busi.** (Call on various learners from the class.)
- **... please go and walk down those steps.**
- **... stand on top of this pile of sand.**
- **... stand to the left of**
- **... stand to the left of**
- Etc.

Activities

Give learners the following activities using concrete resources, and ask learners to give you oral explanations of what they did.

Activity	Can the learners	Observation
1. Talk about the <i>Simon says</i> game that you played at the beginning of the lesson. What were the learners doing?	<ul style="list-style-type: none">• Follow directions?	
2. Go to DBE worksheet 6 (p. 12) – <i>Positions</i> . Ask: Which fish did we circle? (The third fish/fish in the middle/the fish right of the second fish, etc.) Ask similar questions for the rest of the activity.	<ul style="list-style-type: none">• Describe position?• Use ordinal numbers?	
3. Show the learners the number 5 picture card. Ask: What is the number symbol on the card?	<ul style="list-style-type: none">• Read the number symbol 5?	

Topic 6: Shape and sizes

Concepts and skills for today

- Count objects up to **10**.
- Describe, sort and compare three-dimensional objects according to size.
- Use appropriate language to talk about length e.g. **short, long** and **tall**.
- Use appropriate language to talk about mass e.g. **heavy** and **light**.

Warm-up activity

Tell the learners they are going to talk about pictures today. Ask them what we should do when we want to say something in the class (put up your hand). Tell learners that we should always take turns to speak and respect each other when we speak.

Prepare a collection of objects of different sizes that you can show to the class.

- Give each group of learners three or four objects.
- Ask them to discuss the objects – they should think about things such as the size, mass, etc. of the objects.
- After they have had time to discuss the objects in groups allow different groups to report back to the class about their objects.
- Allow each group to report on at least one object or pair of objects and encourage them to use the vocabulary of length and mass given above.

Activities

Give learners the DBE workbooks for these activities.

Activity	Can the learners:	Observation
1. Ask learners to go to DBE worksheet 8 (p. 16) – <i>Shapes and sizes</i> . Ask learners to point to the truck and car . Ask: Which one is big and which one is small? Do the same with all the other pictures.	<ul style="list-style-type: none">• Describe three-dimensional objects according to size?	
2. Look at the boats. Compare their lengths. Point out <i>short</i> and <i>long</i> . Look at the giraffe and the mouse. Point out <i>tall</i> and <i>short</i> . Etc.	<ul style="list-style-type: none">• Use language to talk about length e.g. short, long and tall?	
3. Look at the hippo and dog. Compare their masses. Point out <i>heavy</i> and <i>light</i> . Etc.	<ul style="list-style-type: none">• Use language to talk about mass e.g. heavy and light?	

Topic 7: Count, compare and add

Concepts and skills for today

- Count objects up to **10**.
- Compare given objects using words such as **more**, **less** or **equal to**.
- Recognise, identify and read numbers.
- Solve verbally stated addition problems.

Warm-up activity

Allow the learners some time to make the dice at the back of the DBE workbook. Put the learners into groups, and make sure each group has completed the task of making the dice. Before starting the activity talk to learners about appropriate behaviour when working in groups. Share the basic rules of group work with your learners.

Activities

Give learners the DBE workbooks for these activities.

Activity	Can the learners	Observation
1. In groups the learners should throw the pairs of dice. They then count the total number of dots that comes up on each throw. They compare the numbers on the two dice using the words <i>more than</i> , <i>less than</i> or <i>equal to</i> . Every learner in the group should have a turn to throw and count the dots and compare the numbers they have counted.	<ul style="list-style-type: none">• Count objects up to 10?• Compare objects using the words more than, less than or equal to?	
2. Ask the learners to add the dots they see on the two dice when they have landed. Note that if the answer goes beyond 10 you need to assist them with it or allow them to leave it out. It could be a challenge for some learners. Use the dots to make up story sums. Assist them as needed.	<ul style="list-style-type: none">• Add objects up to 10?	

Topic 8: Patterns

Concepts and skills for today

- Write the numbers 1, 2, 3, 4 and 5 in the air.
- Match colours.
- Trace patterns.

Warm-up activities

Tell the learners that today they need to listen carefully. You will call out a number between **1** and **5** and then they will have to write it in the air. Ask learners what they should do to ensure that they are able to hear everything you say. Also ask learners what they should do if they didn't hear you.

Draw a few patterns on the board using coloured chalk – such as the following:

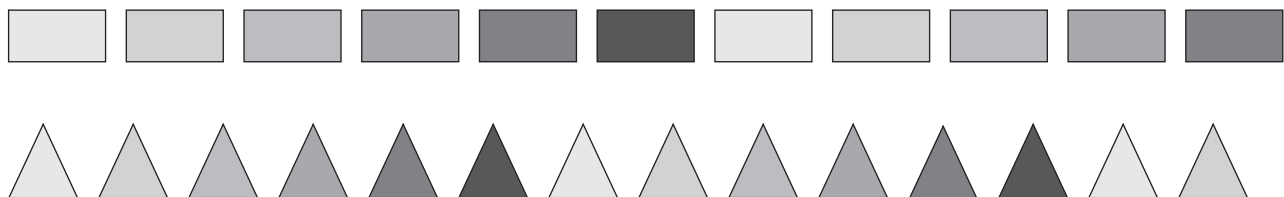

Ask learners to:

- Say what shape (and in what colour) will come next in the pattern.
- Come to the board and draw in the next shape.
- Make up a new pattern using shapes and colours which they draw on the board.
- Ask as many different learners as possible to be involved in the activity.

Activities

Give learners the DBE workbooks for these activities.

Activity	Can the learners	Observation
1. Ask learners to go to DBE worksheet 3 (p. 6). They need to match the colours. Ask: Where is the green shirt? Where are the green shorts? Do the same for the other colours. Ask them to go to DBE worksheet 1 (p. 3). Here they need to match the pictures. Ask questions to see if they can match the pictures correctly. Ask learners to explain their matches if necessary.	<ul style="list-style-type: none"> • Match colours? • Match shapes? 	
2. Ask the learners to go to DBE worksheet 2 (p. 5). Learners need to trace over the pattern. Check that they can trace the pattern neatly. Allow them more opportunities to trace a pattern by allowing them to work on the following worksheets: DBE worksheet 3 (p. 7) DBE worksheet 6 (p. 13) DBE worksheet 7 (p. 15)	<ul style="list-style-type: none"> • Trace a pattern? 	

WEEK 2

LESSON 1: ZERO AND ONE

Teacher's notes

CAPS topics: 1.1 Count objects, 1.16 Mental mathematics, 1.3 Number symbols and number names

Lesson vocabulary: Number symbol and number name

Prior knowledge:

Learners should have been taught how to:

- Identify, recognise and read number symbols 1 to 10.
- Identify, recognise and read number names one to ten.
- Estimate and then count out **10** objects reliably.

Concepts:

- Identify, recognise, read and write number symbol 1
- Identify, recognise, read and write number name – one

Resources: Number symbol and number name cards (0 zero; 1 one), counting objects, old magazines/newspapers, number tracing card (see *Printable Resources*)

DBE workbook activities relevant to this lesson:

- DBE worksheet 9 (pp. 18 and 19)

Assessment: Refer to the tracker for today's formal/informal oral, practical or written assessment activity..

Remediation: Learners can make the number symbol and the number name using little stones. Learners then trace over their number symbol and number name with a finger. Stress the starting point and direction of writing the symbol and the number. Get learners to talk about many different examples of single objects, e.g. one book/one pencil, etc.

Enrichment: See enrichment activity cards – learners can use any cards from the back of this book.

1. Mental mathematics

1.1 Counting (5 minutes)

Introduce learners to numbers by using number rhymes, songs and games. For example:

One, two, three, four, five;

Once I caught a fish alive;

Six, seven, eight, nine, ten;

Then I let it go again

1.2 Recall and strategies (10 minutes)

Number range 1 to 5. Prepare cards with different numbers of pictures of objects on them. Show learners a card, and they must count the objects they see. Ask questions like: **If I cover three of the objects, how many can you see?**

2. Correction/reflection on homework (15 minutes)

Use a few minutes to explain what is expected when learners get homework. Learners had no homework, but reflection/remediation based on previous work should be done.

3. Lesson content – concept development (30 minutes)

Activity 1: Learners work in groups

- Ask learners to look at their empty desks.
- Ask: **What do you have in front of you?** (Nothing).
- Place a number of objects on the learners' tables (e.g. – a pencil, a pen and a ruler).
- Ask the learners to pick out one object.
- Ask: **What can you tell me about your pencil?** (Learners may answer with a broad range of suggestions – you need to guide them to focus on the *number value* shown by the pencil. It is on its own/there is only one/it is a single pencil.) Ask learners to put the pencil away.
- Ask: **How many pencils do you have in front of you?** (None).
- Explain to learners that when we have no pencils, we have zero pencils.
- Ask learners to take out one pencil again and ask: **Now, what can you tell me about the one pencil?** (Learners may say many things. Guide them to compare the numbers 0 and 1. It is more than zero/it is one more than zero.)
- Do this with a few different examples.

Activity 2: Learners work in groups

- Put the number zero symbol card on the board.
- Point to the number symbol, and explain to the learners how we write the number zero symbol. Stress the starting point and direction when writing the symbol.



- The learners write the number symbol in the air, on the desk with their fingers and on their scrap paper/whiteboards; they trace the number symbol in their workbook and then write it in their workbook.
- Then put the number one symbol card on the board.



- Point to the number symbol and explain to the learners how we write the number one symbol. Stress the starting point and direction when writing the symbol.
- The learners write the number symbol in the air, on the desk with their fingers and on their scrap paper/whiteboards; they trace the number symbol in the workbook and then write it in the workbook.

Activity 3: Whole class activity

- Put the number zero and number one number name cards on the board.

zero **one**

- Point to the number word (zero) and read it to the class.
- Ask the class to read the number word with you. Ask a few learners to read the number word for you.
- Point to the number word (one) and read it to the class.
- Ask the class to read the number word with you. Ask a few learners to read the number word for you.
- Learners will begin learning to recognise and read the number words zero and one. They should know how to write these words by the end of Term 1.

4. Classwork activity (25 minutes) (See next page)

5. Homework activity (5 minutes) (See next page)

6. Reflection on lesson

Term 1 Lesson 1: Zero and one

Classwork

1. Trace over the number name zero and the number symbol 0 to practise the formation. (Learners do this using the number tracing card.)
2. Tear little bits of paper from the magazine/newspaper, and collage the number symbol 1 and the word one in your Mathematics book.

A collage is a picture made by pasting many cut-out pictures together on a page to make a new picture using the cut-outs. Learners can use any cut-outs they wish to make a collage. The final collage will be a large '1' symbol made by pasting cut-out pictures into the outline of a '1' symbol. Here is an example:



3. Cut out one picture from the magazine, and paste it next to the collage.
4. Cut out more pictures of single objects or draw pictures.

Homework

1. Colour one shape each time:

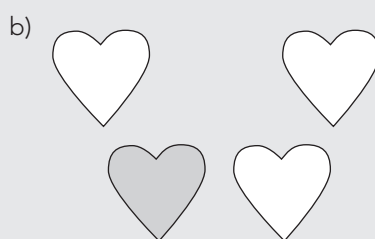

(Any shape can be coloured, not necessarily the one that is shaded above.)

2. Copy these words:

- a) zero
- b) one

LESSON 2: THE NUMBER 2

Teacher's notes

CAPS topics: 1.1 Count objects, 1.3 Number symbols and number names

Lesson vocabulary: Number symbol 2 and number name two

Prior knowledge:

Learners should have been taught how to:

- Identify, recognise and read number symbols 1 to 10.
- Identify, recognise and read number names one to ten.
- Estimate and then count out **10** objects reliably.

Concepts:

- Identify, recognise, read and write number symbol 2
- Identify, recognise, read and write number name – two

Resources: Number symbol and number name cards (2 two), counting objects, old magazines/newspapers, number tracing card (see *Printable Resources*)

DBE workbook activities relevant to this lesson:

- DBE worksheet 10 (pp. 20 and 21)

Assessment: Refer to the tracker for today's formal/informal oral, practical or written assessment activity..

Remediation: Learners can make the number symbol and the number name using little stones. Learners then trace over their number symbol and number name with a finger. Stress the starting point and direction of writing the symbol and the number. Get learners to talk about many different examples of two objects, two eyes/two ears, etc.

Enrichment: See enrichment activity cards – learners can use any cards from the back of this book.

1. Mental mathematics

1.1 Counting (5 minutes)

Introduce learners to numbers by using number rhymes, songs and games. For example:

One, two, buckle my shoe;

Three, four, shut the door;

Five, six, pick up sticks;

Seven, eight, lay them straight;

Nine, ten, a big fat hen!

1.2 Recall and strategies (10 minutes)

Hold up some of your fingers. Learners count your fingers. The learners say the number and write the number symbol in the air with their fingers.

2. Correction/reflection on homework (15 minutes)

Reflection/remediation based on previous day's work/homework.

3. Lesson content – concept development (30 minutes)

Activity 1: Learners work in groups

- Place a number of objects on the learners' tables.
- You need a handful of objects per group for this activity.
- Ask the learners to put out two objects, e.g. **Put out two pencils.**
- Ask learners to place one pencil on the left hand side of their desk, and the other pencil on the right hand side of their desk.
- Ask: **What do you notice about the pencil on the left?** (It is one pencil/it is on its own/it is a single pencil.)
- Repeat with the pencil on the right.
- Ask learners to put the pencils next to each other.
- Ask: **What can you tell me about the pencils now?** (There are two pencils/there is more than one pencil/one and one makes two/two is one more than one.)
- Do this with a few different examples.

Activity 2: Learners work in groups

- Draw 2 objects on the board.
- Point to the drawn objects and ask: **How many objects can you count?** (2).
- Put the number two symbol card on the board.
- Point to the number symbol, and explain to the learners how we write the number symbol. Stress the starting point and direction when writing the symbol.



- The learners write the number symbol in the air, on the desk with their fingers and on their scrap paper/whiteboards; they trace the number symbol in their workbook and then write it in their workbook.

Activity 3: Whole class activity

- Put the number two number name card on the board.

two

- Point to the number word (**two**) and read it to the class.
- Ask the class to read the number word with you. Ask a few learners to read the number word for you.
- Learners will begin learning to recognise and read the number word **two**. They should know how to write this word **by the end of Term 1**.

4. Classwork activity (25 minutes) (See below)

5. Homework activity (5 minutes) (See below)

6. Reflection on lesson

Term 1 Lesson 2: The number 2

Classwork

1. Tear little bits of paper from the magazine/newspaper, and collage the number symbol 2 and the word two in your Mathematics book.
2. Cut out two pictures of the same type of object from the magazine, and paste them next to the collage.
3. Trace over the number name two and the number symbol 2 to practise the formation. (Learners do this using the number tracing card.)

Homework

1. Write the symbol 2
2. Write the word two
3. Colour two shapes each time:

a)



b)



c)

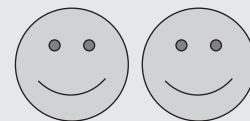

(Any two shapes can be coloured, not necessarily the ones that are shaded above.)

LESSON 3: THE NUMBER 3

Teacher's notes

CAPS topics: 1.1 Count objects, 1.3 Number symbols and number names

Lesson vocabulary: Number symbol 3 and number name three

Prior knowledge:

Learners should have been taught how to:

- Identify, recognise and read number symbols 1 to 10.
- Identify, recognise and read number names one to ten.
- Estimate and then count out **10** objects reliably.

Concepts:

- Identify, recognise, read and write number symbol 3
- Identify, recognise, read and write number name – three

Resources: Number symbol and number name cards (3 three) as suggested in Lesson 1 Resources, counting objects, magazines/newspapers, number tracing card (see *Printable Resources*)

DBE workbook activities relevant to this lesson:

- DBE worksheet 11 (pp. 22 and 23)

Assessment: Refer to the tracker for today's formal/informal oral, practical or written assessment activity..

Remediation: Learners can make the number symbol and the number name using little stones. Learners then trace over their number symbol and number name with a finger. Stress the starting point and direction of writing the symbol and the letters. Get learners to talk about many different examples of three objects, e.g. three books/three pencils, etc.

Enrichment: See enrichment activity cards – learners can use any cards from the back of this book.

1. Mental mathematics

1.1 Counting (5 minutes)

Introduce learners to numbers by using number rhymes, songs and games. For example:

The ants go marching one by one, hurray! hurray!

The ants go marching one by one, hurray! hurray!

The ants go marching one by one

Then they stop and play their drums.

Oh, we're oh so glad that the ants could come today!

(Continue with additional verses – The ants go marching two by two...)

1.2 Recall and strategies (10 minutes)

Write a number name or number symbol from 0 to 2 on the board. Learners must say the number and write the number with their fingers in the air.

2. Correction/reflection on homework (15 minutes)

Reflection/remediation based on previous day's work/homework.

3. Lesson content – concept development (30 minutes)

Activity 1: Learners work in groups

- You need a handful of objects per group for this activity.
- Place a number of objects on the learners' tables.
- Ask the learners to put out **three** objects, e.g. **Put out three pencils.**
- Ask: **What can you tell me about the pencils?** (There are three pencils/there is one and one and one/there are two pencils on the left and one on the right/there are three pencils on the left and zero on the right.)
- Ask: **What can you tell me about the number three?** (It is **1** more than **2**, it is **2** more than **1**, it is **3** more than **zero**.)
- Do this with a few different examples.

Activity 2: Learners work in groups

- Draw **3** objects on the board.
- Point to the drawn objects and ask: **How many objects can you count?** (3).
- Put the number three symbol card on the board.
- Point to the number symbol, and explain to the learners how we write the number symbol. Stress the starting point and direction when writing the symbol.



- The learners write the number symbol in the air, on the desk with their fingers and on their scrap paper/whiteboards; they trace the number symbol in their workbook and then write it in their workbook.

Activity 3: Whole class activity

- Put the number three number name card on the board.

three

- Point to the number word (**three**) and read it to the class.
- Ask the class to read the number word with you. Ask a few learners to read the number word for you.
- Learners will begin learning to recognise and read the number word **three**. They should know how to write this word **by the end of Term 1**.

4. Classwork activity (25 minutes) (See below)

5 Homework activity (5 minutes) (See below)

6. Reflection on lesson

Term 1 Lesson 3: The number 3

Classwork

1. Trace over the number name three and the number symbol 3 to practise the formation. (Learners do this using the number tracing card.)
2. Tear little bits of paper from the magazine/newspaper, and collage the number symbol 3 and the word three in your Mathematics book.
3. Cut out three pictures of the same type of object from the magazine, and paste them next to the collage.

Homework

1. Write the symbol 3
2. Write the word three
3. Colour three shapes each time:

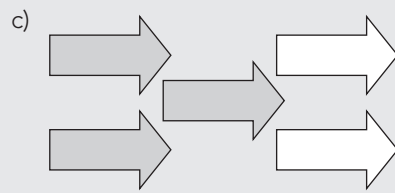
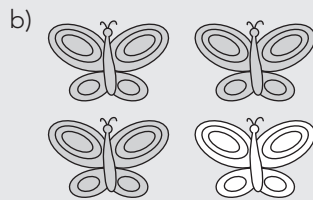
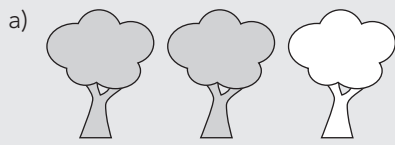

(Any two shapes can be coloured, not necessarily the ones that are shaded above.)

LESSON 4: COMPARE AND ORDER NUMBERS 1 TO 3

Teacher's notes

CAPS topics: 1.1 Count objects, 1.4 Describe, compare and order numbers

Lesson vocabulary: Many, few, most, least, more than, less than, the same as, just as many as, different, smaller than, greater than, smallest, greatest

Prior knowledge:

Learners should have been taught how to:

- Estimate and then count out **10** objects reliably.
- Describe, compare and order a collection of objects up to **10**.

Concepts:

- Describe and compare a collection of objects and numbers. (1–3)
- Describe and order a collection of objects and numbers. (1–3)

Resources: Counters, number symbol cards, flashcards (*more, less, the same as*)

DBE workbook activities relevant to this lesson:

- DBE worksheet 13 (pp. 28 and 29)

Assessment: Refer to the tracker for today's formal/informal oral, practical or written assessment activity..

Remediation: Ask one learner to hold up two pencils. Ask the second learner to hold up three pencils. Ask the learners: **Who has less pencils? Who has more pencils?** Do the same with crayons. Ask the learners to put out one, two and three pencils in order from most to least and then from least to most.

Enrichment: See enrichment activity cards – learners can use any cards from the back of this book.

1. Mental mathematics

1.1 Counting (5 minutes)

Introduce learners to numbers by using number rhymes, songs and games. For example:

One potato, two potatoes;

Three potatoes, four;

Five potatoes, six potatoes;

Seven potatoes, MORE!

1.2 Recall and strategies (10 minutes)

Show learners pictures in magazines, books, posters and cards. Learners must count the objects, say the number and write the number with their fingers in the air.

2. Correction/reflection on homework (15 minutes)

Reflection/remediation based on previous day's work/homework.

3. Lesson content – concept development (30 minutes)

Activity 1: Learners work in pairs

- You need a handful of objects per group for this activity.
- Give each learner three counters.
- Ask one of the learners in each pair to take away one counter.
- Ask questions such as: **What can you tell me about your counters?** (I have three counters/She has two counters/I have more counters than her/She has less counters than me.)
- Ask questions like: **How many more counters do you have?** (I have one more) **How many less counters do you have?** (I have one less.)
- Point to the flash cards to encourage learners to use the new language (*more than/less than*).
- Vary the number of counters each learner has (up to **3** each), and repeat the above steps a few times. Get learners to tell you which flashcard you must point to.

Activity 2: Learners work in groups

- You need a handful of objects per group for this activity.
- Make sure each learner has two counters.
- Ask: **What can you tell me about your counters?** (We both have two counters/We each have the same number of counters.)
- Point to the appropriate flashcards as learners use the terminology (the same as).
- Vary the number of counters each learner has (up to **3** each), and repeat the above steps a few times. Get learners to tell you which flashcard you must point to.

Activity 3: Learners work in pairs

- Give each pair of learners the number symbol cards 0–3.
- Each learner selects a card and places it on their desk in front of them.
- Each pair of learners compares their cards, using the appropriate terminology (e.g. **3** is *more than 2* or **0** is *less than 1* etc.)
- Learners must order the cards from most to least and then least to most.
- Ask questions like, **What can you tell me about your cards?** to encourage learners to use the appropriate terminology (*most, least, more than, less than*).

4. Classwork activity (25 minutes) (See next page)

5. Homework activity (5 minutes) (See next page)

6. Reflection on lesson

Term 1 Lesson 4: Compare and order numbers 1 to 3

Classwork

1. Tick the boxes that have the same number of counters.

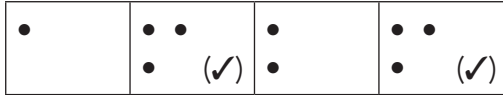

2. Tick the boxes that have more counters than the first box.

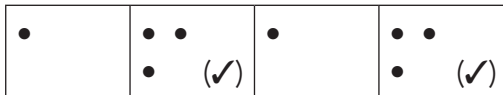

3. Tick the boxes that have less counters than the first box.

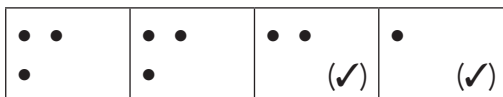

4. Draw one more shape on the right-hand side.

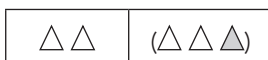

5. Draw one less shape on the right-hand side.



6. Write these numbers in the correct order from smallest to biggest.



Homework

1. Rewrite these numbers from biggest to smallest and draw the counters.



2. Rewrite these numbers from smallest to biggest and draw the counters.



WEEK 3

LESSON 5: THE NUMBER 4

Teacher's notes

CAPS topics: 1.1 Count objects, 1.16 Mental mathematics, 1.3 Number symbols and number names

Lesson vocabulary: Number symbol 4 and number name four

Prior knowledge:

Learners should have been taught how to:

- Identify, recognise and read number symbols and number names 1 to 10.
- Estimate and then count out 10 objects reliably.

Concepts:

- Identify, recognise, read and write number symbol 4
- Identify, recognise, read and write number name – four

Resources: Number symbol and number name cards (4 four) as suggested in *Lesson 1 Resources*, counting objects, magazines/newspapers

DBE workbook activities relevant to this lesson:

- DBE worksheet 14 (pp. 30 and 31)

Assessment: Refer to the tracker for today's formal/informal oral, practical or written assessment activity..

Remediation: Learners can make the number symbol and the number name using little stones. Learners then trace over their number symbol and number name with a finger. Stress the starting point and direction of writing the symbol and the number. Get learners to talk about many different examples of four objects, e.g. four books/four pencils, etc.

Enrichment: See enrichment activity cards – learners can use any cards from the back of this book.

1. Mental mathematics

1.1 Counting (5 minutes)

Introduce learners to numbers by using number rhymes, songs and games. For example:

Five little ducks went out one day

Over the hill and far away

Mother Duck said Quack, quack, quack, quack.

But only four little ducks came back

Four little ducks went out one day... continue...

1.2 Recall and strategies (10 minutes)

Show the learners two strings of beads at a time. Ask learners to count the beads. Ask questions like

What can you tell me about the strings of beads? (That string has more beads/that string has less beads/that string has one more bead/that string has one less bead.)

2. Corrections/reflection on homework – 15 minutes

Reflection/remediation based on previous day's work/homework.

3. Lesson content – concept development (30 minutes)

Activity 1: Learners work in groups

- You need a handful of objects per group for this activity.
- Place a number of objects on the learners' tables.
- Ask the learners to put out four objects, e.g. **Put out four pencils.**
- Ask: **What can you tell me about the pencils?** (There are four pencils/there is one and one and one and one/there are two pencils on the left and two on the right/there are three pencils on the left and one on the right/there are four pencils on the left and zero on the right.)
- Ask: **What can you tell me about the number four?** (It is **1 more than 3**, it is **2 more than 2**, it is **3 more than 1**, it is **4 more than zero**, it is **1 less than 5**.)
- Do this with a few examples.

Activity 2: Learners work in groups

- Draw 4 objects on the board.
- Point to the drawn objects and ask: **How many objects can you count?** (4).
- Put the number four symbol card on the board.
- Point to the number symbol, and explain to the learners how we write the number symbol. Stress the starting point and direction when writing the symbol.



- The learners write the number symbol in the air, on the desk with their fingers and on their scrap paper/whiteboards; they trace the number symbol in their workbook and then write it in their workbook.

Activity 3: Whole class activity

- Put the number four number name card on the board.

four

- Point to the number word (**four**) and read it to the class.
- Ask the class to read the number word with you. Ask a few learners to read the number word for you.
- Learners will begin learning to recognise and read the number word **four**. They should know how to write this word by the **end of Term 1**.

4. Classwork activity (25 minutes) (See below)

5. Homework activity (5 minutes) (See below)

6. Reflection on lesson

Term 1 Lesson 5: The number 4

Classwork

1. Trace over the number name four and the number symbol 4 to practise the formation. (Learners do this using the number tracing card.)
2. Tear little bits of paper from the magazine/newspaper, and collage the number symbol 4 and the word four in your Mathematics book.
3. Cut out four pictures of the same type of object from the magazine, and paste them next to the collage.

Homework

1. Write the symbol 4
2. Write the word four
3. Draw four more triangles in each row.

a) \triangle	($\triangle \triangle \triangle \triangle \triangle$)
b) $\triangle \triangle$	($\triangle \triangle \triangle \triangle \triangle \triangle$)
c) $\triangle \triangle \triangle$	($\triangle \triangle \triangle \triangle \triangle \triangle \triangle$)

LESSON 6: THE NUMBER 5

Teacher's notes

CAPS topics: 1.1 Count objects, 1.16 Mental mathematics, 1.3 Number symbols and number names

Lesson vocabulary: Number symbol 5 and number name five

Prior knowledge:

Learners should have been taught how to:

- Identify, recognise and read number symbols 1 to 10.
- Identify, recognise and read number names one to ten.
- Estimate and then count out **10** objects reliably.

Concepts:

- Compare numbers 0 to 5 and say which is *more than* or *less than*
- Practically solve problems using concrete apparatus and pictures, and explain solutions to problems involving addition and subtraction with answers up to five

Resources: Number symbol and number name cards (5 five) as suggested in *Lesson 1 Resources*, counting objects, magazines/newspapers, beads

DBE workbook activities relevant to this lesson:

- DBE worksheet 17 (pp. 36 and 37)

Assessment: Refer to the tracker for today's formal/informal oral, practical or written assessment activity..

Remediation: Ask the learners to give you five objects, such as five counters/five books/five suitcases. Ask the learners to count the objects again, and take note of how the learners are counting the objects. Learners can make the number symbol and the number name using little stones. Learners then trace over their number symbol and number name with a finger. Stress the starting point and direction of writing the symbol and the letters.

Enrichment: See enrichment activity cards – learners can use any cards from the back of this book.

1. Mental mathematics

1.1 Counting (5 minutes)

Introduce learners to numbers by using number rhymes, songs and games. For example:

Five little cookies in the bakery shop;

Shining bright with sugar on the top;

Along comes (child's name) with a coin to pay;

S/he buys a cookie and takes it away.

Continue with four, three, two and one...

1.2 Recall and strategies (10 minutes)

Learners stand in rows of five. Ask questions like: **Who is first in the row? Who is second, third, fourth and fifth? Who is last?** Give each learner a bead. Let learners roll the beads together from a straight line starting point. Ask: **Whose bead came first? Whose came second? Whose came last?**

2. Correction/reflection on homework (15 minutes)

Reflection/remediation based on previous day's work/homework.

3. Lesson content – concept development (30 minutes)

Activity 1: Learners work in groups

- You need a handful of objects per group for this activity.
- Place a number of objects on the learners' tables.
- Ask the learners to put out five objects, e.g. **Put out five pencils.**
- Ask: **What can you tell me about the pencils?** (There are five pencils/there is one and one and one and one and one/there are five pencils on the left and none on the right/there are three pencils on the left and two on the right, etc.)
- Ask: **What can you tell me about the number five?** (It is **1 more than 4**, it is **2 more than 3**, it is **3 more than 2**, it is **4 more than 1**, it is **5 more than zero**.)
- Do this with a few examples.

Activity 2: Learners work in groups

- Draw **5** objects on the board.
- Point to the drawn objects and ask: **How many objects can you count?** (5).
- Put the number five symbol card on the board.
- Point to the number symbol, and explain to the learners how we write the number symbol. Stress the starting point and direction when writing the symbol.



- The learners write the number symbol in the air, on the desk with their fingers and on their scrap paper/whiteboards; they trace the number symbol in their workbook and then write it in their workbook.

Activity 3: Whole class activity

- Put the number five number name card on the board.

five

- Point to the number word (**five**) and read it to the class.
- Ask the class to read the number word with you. Ask a few learners to read the number word for you.
- Learners will begin learning to recognise and read the number word **five**. They should know how to write this word by the **end of Term 1**.

4. Classwork activity (25 minutes) (See below)

5. Homework activity (5 minutes) (See below)

6. Reflection on lesson







Term 1 Lesson 6: The number 5

Classwork

1. Draw five pictures of the same type of object.
2. Trace over the number name five and the number symbol 5 to practise the formation. (Learners do this using the number tracing card.)
3. Tear little bits of paper from the magazine/newspaper, and collage the number symbol 5 and the word five in your Mathematics books.

Homework

1. Write the symbol 5.
2. Write the word five.
3. Colour five shapes in each row.

a)		()
b)		()
c)		()

LESSON 7: NUMBERS 1 TO 5

Teacher's notes

CAPS topics: 1.1 Count objects, 1.9 Grouping and sharing leading to division, 1.3 Number symbols and number names

Lesson vocabulary: Number symbols 1 to 5 and number names one to five, order, smallest, highest, before, after, between, match

Prior knowledge:

Learners should have been taught how to:

- Identify, recognise and read number symbols 1 to 10.
- Identify, recognise and read number names one to ten.

Concepts:

- Identify, recognise, read and write number symbols 1 to 5
- Identify, recognise, read and write number names one to five

Resources: Strings of 5 beads for each learner, number symbol and number name cards (0–5) counting objects

DBE workbook activities relevant to this lesson:

- DBE worksheet 18 (pp. 38 and 39)

Assessment: Refer to the tracker for today's formal/informal oral, practical or written assessment activity..

Remediation: Ask the learners to give you an object, such as: one bead, two shapes, three blocks, four Unifix cubes, and five balls. Learners then build the number symbols and number names with counters, stones or any other concrete resource available.

Enrichment: See enrichment activity cards – learners can use any cards from the back of this book.

1. Mental mathematics

1.1 Counting (5 minutes)

Introduce learners to numbers by using number rhymes, songs and games. (Use previous examples.)

1.2 Recall and strategies (10 minutes)

Give each learner **5** beads on a string. Ask the learners to separate some of the beads by using their fingers.

Ask them to explain what they see (**3** beads and **2** beads make **5** beads/**1** bead and **4** beads make **5** beads).

2. Correction/reflection on homework (15 minutes)

Reflection/remediation based on previous day's work/homework.

3. Lesson content – concept development (30 minutes)

Activity 1: Learners work in groups

- You need a handful of objects per group for this activity.
- Place a number of objects on the learners' tables.
- Ask the learners to put out e.g. one bead, two pencils, three crayons, four counters and five Unifix cubes.
- Ask the learners to then draw one bead, two pencils, three crayons, four counters and five Unifix cubes on their scrap paper/whiteboards
- Point to the learners' drawings and ask: **How many beads, pencils, crayons, counters, Unifix cubes do you count?**

Activity 2: Learners work in groups

- Point to the number symbols 0, 1, 2, 3, 4 and 5, and ask the learners: **What is this number? Can you find/point to one of your drawings that matches this number?**
- Point to the number names zero, one, two, three, four and five. Ask the learners to write the number names in the air, to build the number names with small stones, to write the number names on scrap paper/whiteboards, and to write the number names in their workbooks.
- Ask learners to match the objects or their drawings of objects to each number name.

Activity 3: Learners work in groups

- Give learners number symbol cards 1–5 randomly. Ask learners to place number symbol cards in order from smallest to highest.
- Ask questions such as:
 - **Which number is after 2?**
 - **Which number is before 2?**
 - **Which number is between 2 and 4?**
- Repeat with number names and drawings.

4. Classwork activity (25 minutes) (See next page)

5. Homework activity (5 minutes) (See next page)

6. Reflection on lesson

Term 1 Lesson 7: Numbers 1 to 5

Classwork





1. Draw 1 more square in each row:

- a) ()
- b) ()
- c) ()
- d) ()
- e) ()

2. Trace the number names (Learners do this using the resource)
 one two three four five



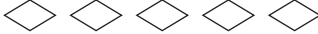

3. Trace the symbols (Learners do this using the resource)
 1 2 3 4 5

4. Circle the correct number

A		(1)	2	3	4	5
B		1	2	(3)	4	5
C		1	2	3	4	(5)
D		1	(2)	3	4	5
E		1	2	3	(4)	5

Homework

Fill in the missing number symbols and number names, and draw the pictures.

a)	1	(one)	()
b)	(2)	(two)	()
c)	(3)	three	()
d)	4	(four)	()
e)	(5)	five	()

LESSON 8: ADDITION UP TO 4

Teacher's notes

CAPS topics: 1.1 Count objects, 1.16 Mental mathematics, 1.6 Problem-solving techniques, 1.7 Addition and subtraction

Lesson vocabulary: How many, altogether, and, makes, more than/less than/the same amount as

Prior knowledge:

Learners should have been taught how to:

- Use concrete apparatus and physical number ladders to solve addition and subtraction story sums in context.
- Explain own solutions to problems involving addition and subtraction with answers up to 10.

Concepts:

- Practically solve problems using concrete apparatus and pictures and explain solutions to problems involving addition and subtraction with answers up to four

Resources: Counters, cards (four cards with the same picture on each one, e.g. one apple drawn on each card), small stones

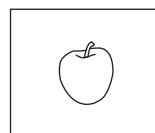
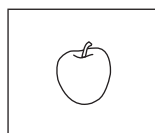
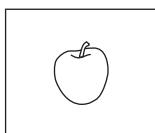
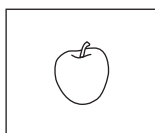

DBE workbook activities relevant to this lesson:

- DBE worksheet 15 (pp. 32 and 33)

Assessment: Refer to the tracker for today's formal/informal oral, practical or written assessment activity.

Remediation: Learners work with counters in pairs. They arrange counters to find the bonds of 4, e.g. $\bullet + \bullet\bullet\bullet$; $\bullet\bullet + \bullet\bullet$; $_ + \bullet\bullet\bullet\bullet$; $\bullet\bullet\bullet + \bullet$ etc.

Enrichment: See enrichment activity cards – learners can use any cards from the back of this book.

1. Mental mathematics

1.1 Counting (5 minutes)

Introduce learners to numbers by using number rhymes, songs and games. Let learners provide suggestions.

1.2 Recall and strategies (10 minutes)

Show learners two pictures of different amounts of objects. Ask learners, **What can you tell me about the pictures?** Learners must count the objects in the pictures and compare them using the words *more than/less than/the same amount as*.

2. Correction/reflection on homework (15 minutes)

Reflection/remediation based on previous day's work/homework.

3. Lesson content – concept development (30 minutes)

Activity 1: Whole class activity

- You need a handful of stones/other counters per group for this activity.
- Ask learners to place their stones in front of them on their desks. The learners use the stones as you use the cards.
- **Ask the learners to count the stones (four).**
- **Model the counting by holding up the cards.**
- Place one card on the board. Learners put **1** stone in front of them.
- Ask: **How many apples do you see?** (one).
- Add two more apples (cards for the teacher/stones for the learners).
- Ask: **How many apples do you see now?** (three).
- Ask: **How did you get your answer?** (I counted all the stones/I had **one** stone, and then I counted **two** more, which makes **three**.)
- Repeat with other combinations of numbers (e.g. 0 apples + 4 apples = 4 apples).

Activity 2: Learners work in pairs

- Repeat Activity 1, but this time, allow learners to work independently in their pairs without modelling the sum for them. They show each other one sum at a time, taking turns.
- Walk around the class to check that learners can demonstrate how to add pairs of numbers together.
- Encourage learners who seem interested to add number that go beyond 5 but do not force this.
- Ask learners to tell you what they are doing:
- For example (if they are using stones), ••• • (Learners say **three** stones and **one** stone makes **four** stones).
- Ask learners to show you (and each other) as many different sums as they can.

4. Classwork activity (25 minutes) (See next page)

5. Homework activity (5 minutes) (See next page)

6. Reflection on lesson

Term 1 Lesson 8: Addition up to 4

Classwork

1. Complete the following:

a)	• and ••• makes _ (4)
b)	•• and _ (2) makes ••••
c)	• and _ (3) makes ••••
d)	••• and • makes _ (4)
e)	••• and _ (1) makes ••••

2. Draw more counters to make 4.

a)	•	(• •••)
b)	•••	(•••• •)
c)	••	(•• ••)
d)		(••••)

3. Themba has 2 green apples and 2 red apples. How many apples does he have now?

(•• •• 2 and 2 makes 4)

Homework

1. How many do you have?

- a) • and •• makes _ (3)
- b) •• and _ (1) makes •••
- c) • and • makes _ (2)
- d) • and _ (3) makes ••••

WEEK 4

LESSON 9: ADDITION UP TO 5

Teacher's notes

CAPS topics: 1.1 Count objects, 1.16 Mental mathematics, 1.12 Techniques (methods or strategies), 1.13 Addition and subtraction

Lesson vocabulary: How many, altogether, and, makes, add

Prior knowledge:

Learners should have been taught how to:

- How to add and subtract up to 5 using concrete apparatus and pictures.

Concepts:

- Estimate and then count out 5 objects reliably
- Compare numbers 5, and say which is more or less
- Practically solve problems using concrete apparatus and pictures, and explain solutions to problems involving addition and subtraction with answers up to five
- Number bonds to 5

Resources: Counters, 1–5 number symbol cards

DBE workbook activities relevant to this lesson:

- DBE worksheet 20 (pp. 42 and 43)

Assessment: Refer to the tracker for today's formal/informal oral, practical or written assessment activity..

Remediation: Give learners five counters. Ask the learners to show you the following on their tables to revise the meaning of the words *more* and *less*:

Show me 1 less than 5 (4 counters)	Place 2 counters on the table. Show me 3 more. (5)
Show me 2 less than 5 (3 counters)	Place 4 counters on the table. Show me 1 more. (5)
Show me 3 less than 5 (2 counters)	Place 3 counters on the table. Show me 2 more. (5)

Enrichment: See enrichment activity cards – learners can use any cards from the back of this book.

1. Mental mathematics

1.1 Counting (5 minutes)

Introduce learners to numbers by using number rhymes, songs and games. Let learners suggest rhymes/songs/games.

1.2 Recall and strategies (10 minutes)

Give learners 1–5 number cards. Ask them to choose any two cards. Ask: **What can you tell me about your numbers?** (This number is smaller/this number is bigger/This is **2** more than that number, etc.)

2. Correction/reflection on homework (15 minutes)

Reflection/remediation based on previous day's work/homework.

3. Lesson content – concept development (30 minutes)

Activity 1: Learners work in pairs

- Give each pair of learners 5 counters.
- Write the following numbers on the board: 3, 2, 5, 4, 1.
- Ask the learners to show each other (in their pairs) the number with their counters.
 - 3 (○○○) 2 (○○) 5 (○○○○○) 4 (○○○○) 1 (○)

Activity 2: Learners work in pairs

- Ask: **What can you tell me about the number five?**
- Learners tell each other as many different sums as they can make using 5 as the total. For example:
 - one and four gives us ... (five)
 - two and three gives us ... (five)
 - three and two gives us ... (five)

Activity 3: Whole class activity

- Draw the following on the board
□ and □□□□ makes □ □□ and □□□ makes □ □□□ and □□ makes □
- Ask the learners what must be written in the box, and learners use their counters to solve the problems.
- Ask learners to explain what they have done (assist by modelling the language in order to introduce the number sentence to the learners).
 - 1 and 4 makes 5 2 and 3 makes 5 3 and 2 makes 5

Activity 4: Whole class activity

- Tell learners to fold their page in half and to throw five counters onto the page.
- Learners must see how many counters land on either side of the fold line and write a sum using the two numbers.
- Learners record what they see as a number sentence on their scrap paper/whiteboards/in their maths exercise book.
 - •• ••• 2 and 3 makes 5
 - ••••• 0 and 5 makes 5
 - ••••• • 4 and 1 makes 5
 - • •••• 1 and 4 makes 5

4. Classwork activity (25 minutes) (See below)

5. Homework activity (5 minutes) (See below)

6. Reflection on lesson

Term 1 Lesson 9: Addition up to 5

Classwork

1. Count and write how many.

a) $\begin{array}{c} \bullet \bullet \\ \bullet \bullet \bullet \end{array}$ (5)

b) $\begin{array}{c} \bullet \bullet \bullet \\ \bullet \bullet \end{array}$ (5)

c) $\begin{array}{c} \bullet \bullet \bullet \\ \bullet \bullet \end{array}$ (5)

2. Draw one more.

$\begin{array}{c} \bullet \bullet \\ \bullet \bullet \end{array} \left\{ \begin{array}{c} \bullet \bullet \\ \bullet \bullet \bullet \end{array} \right\}$

3. Draw two more.

$\bullet \bullet \bullet (\bullet \bullet \bullet \bullet \bullet)$

4. Draw three more.

$\bullet \bullet (\bullet \bullet \bullet \bullet \bullet)$

5. Write a number sentence for:

a) $\bullet \bullet \bullet$ and $\bullet \bullet$ makes $_$ (5) So, $_$ (3) and $_$ (2) is $_$ (5)

b) $\bullet \bullet$ and $\bullet \bullet \bullet$ makes $_$ (5) So, $_$ (2) and $_$ (3) is $_$ (5)

c) \bullet and $\bullet \bullet \bullet \bullet$ makes $_$ (5) So, $_$ (1) and $_$ (4) is $_$ (5)

6. Solve the following by making a drawing and writing a number sentence

a) Nosisi has 2 green marbles and 3 red marbles.

How many marbles does she have? (5 marbles $\bullet \bullet \bullet \bullet \bullet$)

c) Nosisi has 1 blue marble and 4 green marbles.

How many marbles does Nosisi have? (5 marbles $\bullet \bullet \bullet \bullet \bullet$)

Homework

1. Write a number sentence for:

a) $\bullet \bullet \bullet \bullet$ and \bullet makes $_$ (5) So, $_$ (4) and $_$ (1) makes $_$ (5)

b) $\bullet \bullet \bullet$ and $\bullet \bullet$ makes $_$ (5) So, $_$ (3) and $_$ (2) makes $_$ (5)

LESSON 10: COUNTING ON – ADD UP TO 5

Teacher's notes

CAPS topics: 1.1 Count objects, 1.9 Grouping and sharing leading to division, 1.12 Techniques (methods or strategies), 1.13 Addition and subtraction

Lesson vocabulary: More than, how many, altogether, and, makes, counting on, addition, more than, the same as

Prior knowledge:

Learners should have been taught how to:

- Identify, recognise, read and write the number symbols 1 to 5 and the number names one to five

Concepts:

- Use the following techniques when solving addition and subtraction problems and explain solutions to problems: concrete apparatus, number lines
- Practise number bonds 1–5

Resources: Counters (2 different colours), number symbol and number name cards (0–5)

DBE workbook activities relevant to this lesson:

- N/A

Assessment: Refer to the tracker for today's formal/informal oral, practical or written assessment activity..

Remediation: Doing addition by counting all. Ask: **What is one more than 4?** Learners will count out **4** counters, then count out **1** counter, then count all **5** counters. Do more examples of this. Work towards getting learners to count on instead of counting all.

Enrichment: See enrichment activity cards – learners can use any cards from the back of this book.

1. Mental mathematics

1.1 Counting (5 minutes)

Introduce learners to numbers by using number rhymes, songs and games. (Use previous examples.)

1.2 Recall and strategies (10 minutes)

Give each learner 1–5 number cards. Ask them to choose one card. Ask questions like, **Can you give me a number that is one more? Can you give me a number that is one less? What can you tell me about this number?** Learners must use the language of *more than*, *less than* and *the same as* and also describe numbers as (e.g.) 5 is 1 more than 4.

2. Correction/reflection on homework (15 minutes)

Reflection/remediation based on previous day's work/homework.

3. Lesson content – concept development (30 minutes)

Activity 1: Learners work in groups

- Place **five** red counters and **five** blue counters on the learners' desks.
- Ask the learners to give you **three** red counters and **two** blue counters.
- Ask learners: **What can you tell me about what you see?** (I counted **3** red counters and then I counted **2** blue counters, and together that makes **5** counters.)
- Encourage learners to count on by telling them to **Count out three counters. Now hold that number in your head, and count on two more** (1, 2, 3 ... 4, 5).
- Model the use of the language of addition by following up with questions like: **So what will 3 and 2 be when we add the numbers together? (3 and 2 makes 5).**
- Do more examples like this. For example take 1 red counter and 4 blue counters or no red counters and 5 blue counters. Talk about the addition sentences that you can make. ($1 + 4 = 5$; $0 + 5 = 5$ etc.)

Activity 2: Whole class activity

- Draw a number line numbered from 0 to 5 on the floor.
- Ask learners: **Where do you think I should start if I want to count up to 5?** (Learners might say on 1, but show them that you count the steps that you take. This means that when you start on **1** you will step onto **2 after you count 1. To land on 1 when you count you need to start at 0.**) Help learners to understand that you must start counting from zero.
- Ask a few learners to show the counting in steps along the number line on the floor from 0 to 5.
- Ask a learner to stand at 0 on the number line – then to walk 3 steps up to the number 3 and then to walk another 2 steps up to the number 5.
- Ask learners to point to 3 on the number line, and then to count on to five: 4, 5.
- Ask: *What have we shown on the number line?* (That $3 + 2 = 5$).
- Do a few examples like this (using the pairs 1 and 4 and 0 and 5).

4. Classwork activity (25 minutes) (See next page)

5. Homework activity (5 minutes) (See next page)

6. Reflection on lesson

Term 1 Lesson 10: Counting on – add up to 5

Classwork

1. Draw more counters to make 5:

- a) □□□□ 1 more (□□□□ □)
- b) □□□ 2 more (□□□ □□)
- c) □□ 3 more (□□ □□□)
- d) □ 4 more (□ □□□□)

2. Complete the following:

- a) 2 more than 3 is □ (5)
- c) 1 more than 4 is □ (5)

3. Show the number sentence on a number line.

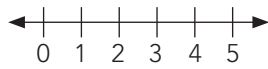

a) 3 more than 2 is □ (5)

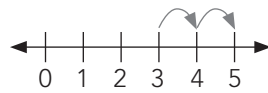

b) 4 more than 1 is □ (5)

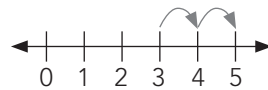

Homework

Draw the following:

- a) 1 more than 3 is □ (••• •4)
- b) 2 more than 2 is □ (•• ••4)

LESSON 11: BREAKING DOWN AND BUILDING UP NUMBERS TO 5

Teacher's notes

CAPS topics: 1.2 Count forwards and backwards, 1.16 Mental mathematics, 1.6 Problem-solving techniques, 1.13 Addition and subtraction

Lesson vocabulary: Break down numbers, number sentence, number bonds, number facts, addition, subtraction

Prior knowledge:

Learners should have been taught how to:

- Add and subtract up to 5 using concrete apparatus, number lines and pictures.
- Practise the bonds up to 5.

Concepts:

- Use the following techniques when solving addition and subtraction problems (0–5), and explain solutions to problems: concrete apparatus, number lines
- Practise number bonds to 5

Resources: Counters, number symbol cards, beads

DBE workbook activities relevant to this lesson:

- DBE worksheet 25 (pp. 54 and 55)

Assessment: Refer to the tracker for today's formal/informal oral, practical or written assessment activity.

Remediation: Practice the concept by first breaking down numbers smaller than five. Give the learners 5 counters. Say: **Show the combinations that will give you an answer of 3 (2 and 1 is 3 etc.). Show the combinations that will give you an answer of 4 (3 and 1 is 4, etc.). Show the combinations that will give you an answer of 5 (4 and 1 is 5 or 1 and 4 is 5, etc.).**

Enrichment: See enrichment activity cards – learners can use any cards from the back of this book.

1. Mental mathematics

1.1 Counting (5 minutes)

Learners count from 1–10 using a number board. Learners must point to the numbers as they say them. Ask learners to count on to 10 from different starting points e.g. 3, 7, 5, etc. Learners count from 10–1 using the number board.

1.2 Recall and strategies (10 minutes)

Give each learner **five** beads. Ask questions like: **Move one bead to the right. How many are left? If we take another bead to the right, how many do we have on the left? Move three beads to the right, how many are left?**

2. Correction/reflection on homework (15 minutes)

Reflection/remediation based on previous day's work/homework.

3. Lesson content – concept development (30 minutes)

Activity 1: Learners work in groups

- Give the learners five counters and ask them, **How many different ways can you break the number 5 down?**

- ○○○ ○○ 3 and 2 is 5
- ○○ ○○○ 2 and 3 is 5
- ○ ○○ ○○ 1 and 2 and 2 is 5, etc.

Activity 2: Learners work in pairs

- Give them the number cards.
- Ask them to show you all the combinations that will give you five e.g. 1 4, 2 3, 1 2 2, etc.
- Ask the learners to draw the combinations e.g. ○○○ ○○

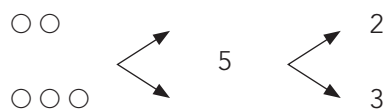

Activity 3: Whole class activity

- Use counters and number lines to do the following activities with the learners.
- Encourage them to give you as many number sentences as they can, with an answer of five.
- Learners can add pairs of number – for example $2 + 2 = 4$.
- Learners can also combine three numbers at a time – for example $1 + 2 + 2 = 5$.
- Draw the sums on the board using number lines and counters to demonstrate the addition, especially when more than two numbers are combined.

3 and 2 is 5 	1 and 4 is 5
1 and 2 and 2 is 5 	3 and 1 and 1 is 5

4. Classwork activity (25 minutes) (See next page)

5. Homework activity (5 minutes) (See next page)

6. Reflection on lesson

Term 1 Lesson 11: Breaking down and building up numbers to 5

Classwork

1. Count the beads and write the number sentence.

- a) ○ ○ ○ □ (2) and □ (1) is □ (3)
b) ○ ○ ○ □ (1) and □ (2) is □ (3)
c) ○ ○ ○ ○ □ (3) and □ (1) is □ (4)
d) ○ ○ ○ ○ □ (1) and □ (3) is □ (4)
e) ○ ○ ○ ○ □ (2) and □ (2) is □ (4)
f) ○ ○ ○ ○ ○ □ (4) and □ (1) is □ (5)
g) ○ ○ ○ ○ ○ □ (1) and □ (4) is □ (5)
h) ○ ○ ○ ○ ○ □ (3) and □ (2) is □ (5)
i) ○ ○ ○ ○ ○ □ (2) and □ (3) is □ (5)
j) ○ ○ ○ ○ □ (2) and □ (1) and □ (1) is □ (4)
k) ○ ○ ○ ○ ○ □ (1) and □ (2) and □ (2) is □ (5)
l) ○ ○ ○ ○ ○ □ (2) and □ (2) and □ (1) is □ (5)
m) ○ ○ ○ ○ ○ □ (2) and □ (1) and □ (2) is □ (5)
n) ○ ○ ○ ○ ○ □ (3) and □ (1) and □ (1) is □ (5)

Homework

Draw the counters and write the answers.

- a) 2 and 1 is □ (3 ○ ○ ○)
b) 2 and 2 is □ (4 ○ ○ ○ ○)
c) 2 and 3 is □ (5 ○ ○ ○ ○ ○)
d) 4 and 1 is □ (5 ○ ○ ○ ○ ○)

LESSON 12: ADDITION DOUBLES – 1 TO 5

Teacher's notes

CAPS topics: 1.2 Count forwards and backwards, 1.16 Mental mathematics, 1.6 Problem-solving techniques, 1.13 Addition and subtraction

Lesson vocabulary: Double, plus, before/after, more than, less than, the same as, in between, number bonds

Prior knowledge:

Learners should have been taught how to:

- Build up and break down numbers up to five.
- Practise the bonds up to 5.

Concepts:

- Use the following techniques when solving addition and subtraction problems (0–5) and explain solutions to problems: concrete apparatus, number lines
- Practise number bonds to 5

Resources: Counters, picture of butterfly, Unifix cube

DBE workbook activities relevant to this lesson:

- DBE worksheet 26 (pp. 56 and 57)

Assessment: Refer to the tracker for today's formal/informal oral, practical or written assessment activity..

Remediation: Give the learners Unifix cubes or counters. Tell them to show you **2**. Tell them to double it. Tell them, **We can say 2 and 2 is 4 or double 2 is 4**. Show this on a number line. Do the same with double 1.

Enrichment: See enrichment activity cards – learners can use any cards from the back of this book.

1. Mental mathematics

1.1 Counting (5 minutes)

Learners count from 1–10 using a number board. Learners must point to the numbers as they say them.

Ask learners to count on to 10 from different starting points e.g. 3, 7, 5, etc. Learners count from 10–1 using the number board.

1.2 Recall and strategies (10 minutes)

Point to a number on the number board, and ask learners to tell you what number comes before/after it. In the same way, develop the language of *more than* (point to a number that is more than 4), *less than* (point to a number that is less than 3), *the same as* (point to a number that is the same as 1 and 2 added together) and *in between* (point to the number that is in between 3 and 5), etc.

2. Correction/reflection on homework (15 minutes)

Reflection/remediation based on previous day's work/homework.

3. Lesson content – concept development (30 minutes)

Activity 1: Learners work in groups

- Ask learners to put out **one** counter.
- Ask: **What do you see?** (**one** counter).
- Ask learners to put out another counter.
- Ask: **What do you see now?** (**two** counters/**1** and **1** makes **2**).
- Put the counters together again to start a new display.
- Ask learners to put out **two** counters.
- Ask: **What do you see?** (**two** counters).
- Ask learners to put out another **two** counters.
- Ask: **What do you see now?** (**4** counters/**2** and **2** makes **4**).
- Ask learners what they noticed in the two activities that were done. (We added the same number of counters each time.)
- Explain to learners that *double* means two of the same thing (e.g. twin learners).
- Put the counters together again to start a new display.
- Now ask learners to put down **one** counter and then another **one** and say: **Double 1 is...**
- Learners put down **two** counters and then another **two** and say: **Double 2 is...**

Activity 2: Whole class activity

- Ask the learners to draw one dot, then double it and say, **Double 1 is 2.**
- Ask the learners to draw two dots, then double them and say, **Double 2 is 4.**

4. Classwork activity (25 minutes) (See next page)

5. Homework activity (5 minutes) (See next page)

6. Reflection on lesson

Term 1 Lesson 12: Addition doubles – 1 to 5

Classwork

1. Complete the following by drawing the counters and filling in the numbers.

a) Double 1 is \square (2) \square (1) plus \square (1) is \square (2) (○ ○)

b) Double 2 is \square (4) \square (2) plus \square (2) is \square (4) (○ ○ ○ ○)

2. Double the dots on the wings.

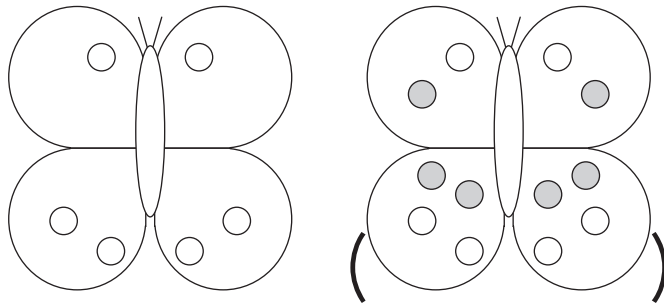

3. Show the following on the number lines.

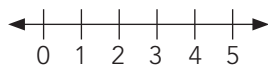

a) Double 1 is 2

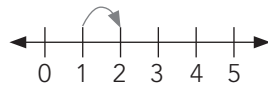

b) $1 + 1 = 2$

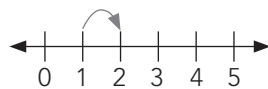

c) Double 2 is 4

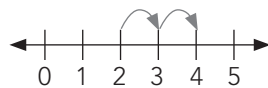

d) $2 + 2 = 4$

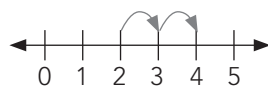

Homework

1. Draw a butterfly in your homework book.

a) Draw 2 dots on one of the top wings and 1 dot on one of the bottom wings.

b) Now double the dots.

2. Draw another butterfly.

a) Draw 1 dot on one of the top wings and 2 dots on one of the bottom wings.

b) Now double the dots.

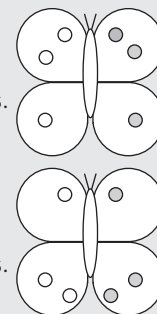

WEEK 5

LESSON 13: ADDITION UP TO 5

Teacher's notes

CAPS topics: 1.2 Count forwards and backwards, 1.16 Mental mathematics, 1.6 Problem-solving techniques, 1.13 Addition and subtraction

Lesson vocabulary: Forwards, backwards, more, add, smallest, biggest

Prior knowledge:

Learners should have been taught how to:

- Add and subtract up to 5 using concrete apparatus and pictures.

Concepts:

- Practically solve problems using concrete apparatus and pictures, and explain solutions to problems involving addition and subtraction with answers up to five
- Number bonds to 5

Resources: Counters, objects, 5-grid cards (as shown alongside)

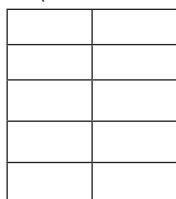

DBE workbook activities relevant to this lesson:

- DBE worksheet 21 (pp. 44 and 45)

Assessment: Refer to the tracker for today's formal/informal oral, practical or written assessment activity..

Remediation: Give the learners 5-grid cards and counters. Ask them to show 4 and 1 on the grid. Ask the learners to move the counter from the right-hand side grid to the left-hand side to fill it. Ask the learners to explain to you what they did (**1 more than 4 is 5, 4 and count on 1 is 5, 4 add 1 is 5**).

Enrichment: See enrichment activity cards – learners can use any cards from the back of this book.

1. Mental mathematics

1.1 Counting (5 minutes)

Learners use a number board to count forwards and backwards in ones to a maximum of 20. Ask learners to start at different numbers, and count on from there.

1.2 Recall and strategies (10 minutes)

Give learners 1–5 number cards. Ask the learners to arrange the cards in order from the smallest to the biggest, and from the biggest to the smallest. Ask: **Which is more: 2 or 3? What can you tell me about 4 and 5?**

Which is less: 3 or 2?, etc.

2. Correction/reflection on homework (15 minutes)

Reflection/remediation based on previous day's work/homework.

3. Lesson content – concept development (30 minutes)

Activity 1: Learners work in pairs

- Give each pair of learners 5 counters.
- Count real life objects to 10. e.g. fingers, toes, pencils, counters, books. This is just to practise counting. Now we are going to focus on adding up to 5.
- Ask learners to use their counters to show how they can make the number 5
○○ ○○○ and ○ ○○○○ and ○○○ ○○, etc.
- Give the learners 5-grid cards. e.g.

○	
○	○
○	○

- Ask learners to look at the first column, **What can you see?** (Three dots).
- Ask learners, **How many spaces are empty?** (2).
- Ask learners, **How many more dots do we need to make 5?** (2).
- Ask the learners to write $3 + 2$. Ask: **What is the total number of dots?** (5).
- Repeat, but this time focus on the second column.
- Ask the learners: **How many spaces are empty?** (3).
- Ask learners: **How many more dots do we need to make 5?** (3).
- Ask the learners to write $2 + 3$. Ask: **What is the total number of dots?** (5).
- Repeat with all of the other combinations of numbers to make 5. (0 and 5; 1 and 4).
- Ask: **What do you notice about the pairs of numbers that make 5?** (There are two number sentences for each pair: $0 + 5$ and $5 + 0$; $1 + 4$ and $4 + 1$; $2 + 3$ and $3 + 2$ all make 5).

4. Classwork activity (25 minutes) (See next page)

5. Homework activity (5 minutes) (See next page)

6. Reflection on lesson

Term 1 Lesson 13: Addition up to 5

Classwork

1. Complete the following.

a) 4 and 1 is \square (5)

○	
○	
○	
○	○

b) 3 and 2 is \square (5)

○	
○	○
○	○

c) 1 and 4 is \square (5)

	○
	○
	○
○	○

d) 2 and 3 is \square (5)

	○
○	○
○	○

e) 1 and 3 is \square (4)

	○
	○
○	○

f) 1 and \square (4) is \square (5)

	○
	○
	○
○	○

2. Draw counters to show:

a) $2 + 1 =$ (●● ● = 3)

b) $3 + 2 =$ (●●● ●● = 5)

c) $1 + 4 =$ (● ●●●● = 5)

Homework

Calculate:

1. 3 and 2 is \square (5)

○	
○	○
○	○

2. 4 and 1 is \square (5)

○	
○	
○	
○	○

3. 5 and \square (0) is \square (5)

○	
○	
○	
○	
○	

LESSON 14: SUBTRACTION UP TO 4

Teacher's notes

CAPS topics: 1.1 Count objects, 1.16 Mental mathematics, 1.12 Techniques (methods or strategies), 1.13 Addition and subtraction

Lesson vocabulary: How many, take away, makes, more, less, subtract

Prior knowledge:

Learners should have been taught how to:

- Use concrete apparatus and physical number ladders to solve addition and subtraction story sums in context.
- Explain own solutions to problems involving addition and subtraction with answers up to 10.

Concepts:

- Practically solve problems using concrete apparatus and pictures, and explain solutions to problems involving addition and subtraction with answers up to four
- Number bonds to 4

Resources: Counters, cards (four cards with the same picture on each one, e.g. one apple drawn on each card), small stones

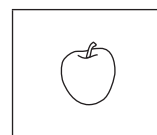
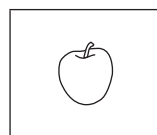
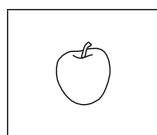
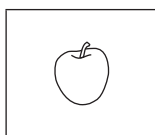

DBE workbook activities relevant to this lesson:

- N/A

Assessment: Refer to the tracker for today's formal/informal oral, practical or written assessment activity..

Remediation: Give learners four counters. Ask them to count them. Ask the learners to show you the following on their tables:

Show me 1 less than 4 (3 counters)	Place 2 counters on the table. Show me 2 more. (4)
Show me 2 less than 4 (2 counters)	Place 1 counter on the table. Show me 3 more. (4)
Show me 3 less than 4 (1 counter)	Place 3 counters on the table. Show me 1 more. (4)

Enrichment: See enrichment activity cards – learners can use any cards from the back of this book.

1. Mental mathematics

1.1 Counting (5 minutes)

Introduce learners to numbers by using number rhymes, songs and games. Let learners provide suggestions.

1.2 Recall and strategies (10 minutes)

Give the learners some beads. Learners must put a different number of beads in each of their hands.

Ask: **Which hand has more in it? Which hand has less in it?** Repeat a few times.

2. Correction/reflection on homework (15 minutes)

Reflection/remediation based on previous day's work/homework.

3. Lesson content – concept development (30 minutes)

Activity 1: Learners work in groups

- You need a handful of counters per group for this activity.
- Write the following numbers on the board: 3, 2, 4, 1, and ask the learners to show it with their counters.
- 3 ●●● 2 ●● 4 ●●●● 1 ●

Activity 2: Learners work in groups

- Revise addition to lead into subtraction.
- This is important because addition and subtraction are inverse relationships and some learners might think about subtraction by using addition. This lesson moves on from the last 5 lessons about addition to introduce subtraction – up to 4.
- Ask the learners to show you how to make 4 with their counters.
 - ● and ●●● gives us four
 - ●● and ●● gives us four
 - ●●● and zero gives us four, etc.
- Learners explain their groupings to the person sitting nearest them.

Activity 3: Learners work in groups

- Ask learners to place their stones in front of them on their desks. The learners use the stones as you use the cards.
- Ask the learners to count the stones (four).
- Model the counting by holding up the cards.
- Ask learners to count the apples (four).
- Tell the learners that you eat one apple (take away one card/stone).
- Ask: **How many apples are left?** (three).
- Ask: **How did you get your answer?** (I had **4** stones then I took **one** away and I was left with **3**.)
- Repeat with other examples (e.g. **3** apples take away **2** apples = **1** apple; **1** apple take away **1** apple = **0** apples etc.)

Activity 4: Whole class activity

- Learners use their counters to do this. Write the following on the board, and ask learners what must be written in the box:
 - ●●●● 4 take away 1 makes (3)
 - ●●● 4 take away 3 makes (1)
 - ●●● 4 take away 4 makes (0), etc.

4. Classwork activity (25 minutes) (See below)

5. Homework activity (5 minutes) (See below)

6. Reflection on lesson

Term 1 Lesson 14: Subtraction up to 4

Classwork

1. How many counters?

a)  (4)



b)  (4)

c)  (4)

2. Draw one more. How many dots are there now?

a)  {  4 }

b)  {  3 }

c)  {  2 }

3. Write a number sentence for:

a)  $_ (4) \text{ take away } _ (1) \text{ makes } _ (3)$

b)  $_ (4) \text{ take away } _ (2) \text{ makes } _ (2)$

c)  $_ (4) \text{ take away } _ (3) \text{ makes } _ (1)$

4. Solve the following by making a drawing and writing a number sentence:

Tom has three sweets. He eats one sweet. How many sweets does he have now?

(2 sweets)

Homework

1. Write a number sentence for:

a)  $_ (4) \text{ take away } _ (1) \text{ makes } _ (3)$

b)  $_ (4) \text{ take away } _ (3) \text{ makes } _ (1)$

LESSON 15: SUBTRACTION UP TO 5

Teacher's notes

CAPS topics: 1.1 Count objects, 1.16 Mental mathematics, 1.6 Problem-solving techniques, 1.7 Addition and subtraction

Lesson vocabulary: How many, altogether, left, and, makes, subtract

Prior knowledge:

Learners should have been taught how to:

- Add and subtract up to 4 using concrete apparatus and pictures.
- Practised the bonds of four.

Concepts:

- Practically solve problems using concrete apparatus and pictures and explain solutions to problems involving addition and subtraction with answers up to five

Resources: Bottle tops on a string or an abacus, enough stones/counters for learners

DBE workbook activities relevant to this lesson:

- DBE worksheet 19 (pp. 40 and 41)

Assessment: Refer to the tracker for today's formal/informal oral, practical or written assessment activity..

Remediation: : Learners take some stones. Tell the learners to put **two** stones on their table. Ask them to add **three** more. **How many stones do you have now? How did you get your answer? (Two stones and three more stones give me five stones.)** Repeat with other examples. Ask learners to put **five** stones on their tables. Ask them to take **one** stone away: **How many do you have left? How did you get your answer?** Repeat with other examples.

Enrichment: See enrichment activity cards – learners can use any cards from the back of this book.

1. Mental mathematics

1.1 Counting (5 minutes)

Introduce learners to numbers by using number rhymes, songs and games. For example:

10 bears in the bed, and the little one said, I'm crowded – roll over;

So, they all rolled over and one fell out;

9 bears in the bed, and the little one said, I'm crowded – roll over; Continue with other numbers...

1.2 Recall and strategies (10 minutes)

You need bottle tops on a string or an abacus. Move the first bead/bottle top to your left. Move the second bead to your left, etc.

2. Correction/reflection on homework (15 minutes)

Reflection/remediation based on previous day's work/homework.

3. Lesson content – concept development (30 minutes)

Activity 1: Learners work in groups

- Learners **place five** stones on their desks.
- Ask learners to count the stones (five).
- Tell learners to imagine that each stone represents an apple. One stone means I have one apple. Two stones is two apples and so on.
- Tell the learners to imagine that you eat **2** apples (take away **2** stones).
- Ask: **How many stones are left?** (three)
- This means if I have 5 apples and I eat 2 of them I will have 3 apples left.
- Ask: **How did you get your answer?** (I had **5** stones then I took **2** away, and I was left with **3**.)
- Repeat with other examples (e.g. **4** apples take away **2** apples = **2** apples; **3** apples take away **0** apples = **3** apples etc.)

Activity 2: Learners work in groups

- Ask the learners to put out five counters.
- Ask learners to take away **3** counters.
- Ask learners, **What can you tell me about what you did?** (I had **5** counters and then I took away **3** counters, and I was left with **2** counters.)
- Model the use of the language of subtraction by following up with questions like, **So what is 5 minus 3?** (**5** take away **3** is **2**).
- Do more examples like this. For example take 1 away one counter or no counters. Talk about the subtraction sentences that you can make. ($5 - 1 = 4$; $5 - 0 = 5$ etc.)

Activity 3: Whole class activity

- Draw a number line on the floor. Revise how to walk along a number line.
- Ask learners: **Where do you think I should start if I want to count up to 5?** (Learners might say on 1, but show them that you count the steps that you take. This means that when you start on **1** you will step onto **2** after you count 1. To land on 1 when you count you need to start at 0.) Help learners to understand that you must start counting from zero.
- Ask a few learners to show the counting in steps along the number line on the floor from 0 to 5 – forwards and backwards.
- Ask learners to demonstrate that **5** take away **2** will give us **3** by using a number line (learners point to 5 on the number line, and count back: 4, 3).
- Ask a learner to stand at 5 on the number line – then to walk 2 steps back on the number line. Ask: **What number is she standing on now?** (3). **What is 5 – 2?** (3)
- Do a few examples like this (using the pairs 1 and 4 and 0 and 5).

4. Classwork activity (25 minutes) (See next page)

5. Homework activity (5 minutes) (See next page)

6. Reflection on lesson

Term 1 Lesson 15: Subtraction up to 5

Classwork

1. Draw less:

- a) $\triangle\triangle\triangle\triangle$ 1 less ($\triangle\triangle\triangle$)
- b) $\triangle\triangle\triangle\triangle$ 2 less ($\triangle\triangle$)
- c) $\triangle\triangle\triangle\triangle$ 3 less (\triangle)
- d) $\triangle\triangle\triangle\triangle$ 4 less (\triangle)

2. Subtract by counting back.

- a) 5 take away 2 is \square ((5), (4), (3))
- b) 5 take away 4 is \square ((5), (4), (3), (2), (1))
- c) 5 take away 3 is \square ((5), (4), (3), (2))
- d) 5 take away 1 is \square ((5), (4))

3. Write a number sentence for.

- a) $\bullet\bullet\bullet\cancel{\bullet}$ (5) take away (2) makes (3)
- b) $\bullet\cancel{\bullet}\cancel{\bullet}\cancel{\bullet}$ (5) take away (4) makes (1)

4. Make a drawing to help you solve the problem.

Noluthando had four bananas. She gave two bananas to Silo.

How many bananas does she have now? (2 bananas $\bullet\bullet\cancel{\bullet}$)

Homework

1. How many counters are left? Draw them.

- a) $\bullet\bullet\bullet\bullet\cancel{\bullet}$ (4 $\bullet\bullet\bullet\bullet$)
- b) $\bullet\cancel{\bullet}\cancel{\bullet}\cancel{\bullet}$ (1 \bullet)
- c) $\bullet\bullet\bullet\cancel{\bullet}$ (3 $\bullet\bullet\bullet$)

LESSON 16: COUNTING BACK – SUBTRACT UP TO 5

Teacher's notes

CAPS topics: 1.16 Mental mathematics, 1.3 Number symbols and number names

Lesson vocabulary: Less, take away, minus, counting back, subtract

Prior knowledge:

Learners should have been taught how to:

- Add and subtract up to 5 using concrete apparatus and pictures.

Concepts:

- Practically solve problems using concrete apparatus and pictures, and explain solutions to problems involving addition and subtraction with answers up to five
- Number bonds to 5

Resources: Coloured counters, Unifix cubes, beads, counter grids (as seen below)

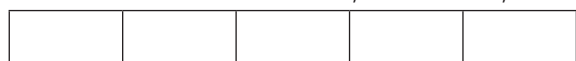

DBE workbook activities relevant to this lesson:

- DBE worksheet 22 (pp. 46 and 47)

Assessment: Refer to the tracker for today's formal/informal oral, practical or written assessment activity..

Remediation: Give the learners the counter grids. Ask them to show **2** and **3** is **5**.



Do the same with **3** and **2**; **4** and **1**; **1** and **4**.

Ask the learners to show **5** take away **2** is **3**.



Do the same with **5** take away **3**; **5** take away **1**; **5** take away **4**.

Enrichment: See enrichment activity cards – learners can use any cards from the back of this book.

1. Mental mathematics

1.1 Counting (5 minutes)

Learners start counting at a given number and stop at another. Learners can use their fingers to help them. Start at three. Count to five.

1.2 Recall and strategies (10 minutes)

Learners give the number that is one more or less than a number given by the teacher. Learners show their answers on a number line.

2. Correction/reflection on homework (15 minutes)

Reflection/remediation based on previous day's work/homework.

3. Lesson content – concept development (30 minutes)

Activity 1: Learners work in pairs

- Revise addition to lead into subtraction. This is important because addition and subtraction are inverse relationships and some learners might think about subtraction by using addition.
- Ask the learners to put out 3 blue counters and 2 red counters.
- Ask: **What can you tell me about your counters? (3 and 2 is 5).**
- Do the same with 4 blue counters and 1 red counter (4 and 1 is 5).

Activity 2: Learners work in pairs

- Ask the learners to put out 5 counters and then take away 3.
- Ask: **What can you tell me about what you did?** (I counted backwards from 5 and got 2/5 minus 3 is 2). Model the language of subtraction for learners so that they become familiar with it.
- Do the same with 5 minus 4; 5 minus 2; 5 minus 1 and 5 minus 0. (Encourage learners to use the language: 5 minus 3 is 2, 5 minus 4 is 1, 5 minus 2 is 3, 5 minus 1 is 4, 5 minus 0 is 5).

Activity 3: Whole class activity

- Use number lines with counters to demonstrate 5 minus 2 is 3.
- Do the same with:
 - 5 minus 4 is 1
 - 5 minus 3 is 2
 - 5 minus 1 is 4.

4. Classwork activity (25 minutes) (See next page)

5. Homework activity (5 minutes) (See next page)

6. Reflection on lesson

Term 1 Lesson 16: Counting back – subtract up to 5

Classwork

1. Draw counters to show the following.

a) 5 take away 3 is (2) (●●●●●)

b) 5 take away 4 is (1) (●●●●●)

c) 5 take away 2 is (3) (●●●●●)

d) 5 take away 1 is (4) (●●●●●)

2. Show the number sentence on a number line

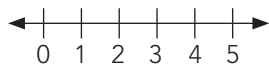

a) $3 - 2 = _ (1)$

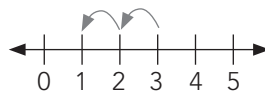

b) $4 - 1 = _ (3)$

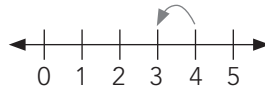

c) $5 - 3 = _ (2)$

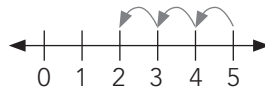

Homework

Draw counters to show the number sentence.

1. 5 take away 3 is \square (2 ●● ●●●)

2. 5 take away 4 is \square (1 ● ●●●●)

WEEK 6

LESSON 17: ADD AND SUBTRACT – NUMBER BONDS AND FAMILY FACTS

Teacher's notes

CAPS topics: 1.1 Count objects, 1.12 Techniques (methods or strategies), 1.13 Addition and subtraction

Lesson vocabulary: Take away, more, less, how many, altogether, left, makes number bonds, number facts, add, subtract

Prior knowledge:

Learners should have been taught how to:

- Add and subtract up to 5 using concrete apparatus and pictures.
- Practise the bonds up to 5.

Concepts:

- Use the following techniques when solving addition and subtraction problems (0–5) and explain solutions to problems: concrete apparatus, number lines
- Practise number bonds 1–5

Resources: Counters of 2 different colours, Unifix cubes

DBE workbook activities relevant to this lesson:

- N/A

Assessment: Refer to the tracker for today's formal/informal oral, practical or written assessment activity..

Remediation: Give learners 5 red counters and 5 blue counters. Get them to show 1 and 4 like this: ○ ● ● ● ● and 4 and 1 like this: ● ● ● ● ○.

Show this on a blank number line  and .

Remove 1 counter from the first number line. Ask them to explain this (5 take away 1 is 4). .

Remove 4 counters from the second number line.

Ask them to explain this (5 take away 4 is 1).  Repeat with all the bonds of 5.

Enrichment: See enrichment activity cards – learners can use any cards from the back of this book.

1. Mental mathematics

1.1 Counting (5 minutes)

Introduce learners to numbers by using number rhymes, songs and games. (Use previous examples.)

1.2 Recall and strategies (10 minutes)

Give each learner 1–5 number cards. Ask them to choose one card. Instruct them: **Give me a number that is one more. Give me a number that is one less.** Ask: **What can you tell me about this number?** Learners must use the language of *more than*, *less than* and *the same as*, and also describe numbers as (e.g.) 1 is 2 less than 3.

2. Correction/reflection on homework (15 minutes)

Reflection/remediation based on previous day's work/homework.

3. Lesson content – concept development (30 minutes)

This is the final lesson on addition and subtraction for Term 1. It is the last in a series of 10 lessons. In this lesson learners revise the bonds of 5 and work with both addition and subtraction to consolidate what they have learners about operations.

Activity 1: Learners work in groups

- Place Unifix cubes of **two** different colours on the learners' tables.
- Ask the learners to take one yellow block and four blue blocks and make a train.
- Learners complete the number sentence orally (**1 and 4 is 5**).
- Repeat with **2** yellow and **3** blue (**2 and 3 is 5**), **3** yellow and **2** blue (**3 and 2 is 5**) and **4** yellow and **1** blue (**4 and 1 is 5**).

Activity 2: Whole class activity

- Draw a 0–5 number line like the one below on the board before the lesson starts.
- Give each learner a number line card (0–5), or ask them to copy it into their books from the board.

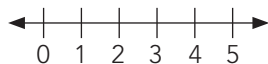

- Do the following practically with them.
- Take **1** yellow block and **4** blue blocks, and place them on the number line.
- Ask the learners to show **1** jump and then **4** more jumps on the number line.
- Repeat with all the bonds of 5.

Activity 3: Whole class activity

- Ask learners to come up to the board and show you the following five family facts on the number line on the board:

2 and 3 (5)	5 take away 2 (3)	5 take away 3 (2)	0 and 5 (5)	1 and 4 (5)	5 take away 0 (5)
5 take away 5 (0)	5 and 0 (5)	4 and 1 (5)	5 take away 1 (4)	5 take away 4 (1)	3 and 2 (5)

- Ask learners to give you the number sentence each time.
- Use Unifix cubes to show the same family facts and write number sentences each time.

4. Classwork activity (25 minutes) (See next page)

5. Homework activity (5 minutes) (See next page)

6. Reflection on lesson

Term 1 Lesson 17: Add and subtract – number bonds and family facts

Classwork

1. Colour the beads to show:

- a) 2 and 3 is 5 (●●○○○)
 b) 1 and 4 is 5 (●○○○○)

2. Cross out the beads to show:

- a) 5 take away 2 is 3 (○○○∅∅)
 b) 5 take away 3 is 2 (○○∅∅∅)
 c) 5 take away 1 is 4 (○○○○∅)
 d) 5 take away 4 is 1 (∅∅∅∅)

3. Colour the beads. Show each one on a number line.

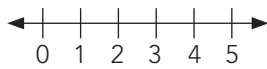

- a) 2 and 3 is (5) (●●○○○)

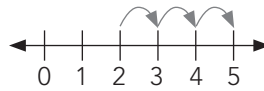

- b) 3 and 2 is (5) (●●●○○)

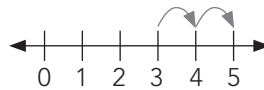

- c) 1 and 4 is (5) (●○○○○)

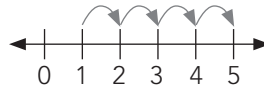

- d) 4 and 1 is (5) (●●●●○)

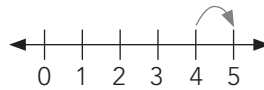

4. Cross out the beads. Show each one on a number line.

- a) 5 take away 3 is (2) (∅∅∅○○)

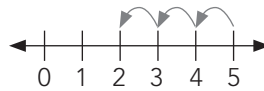

- b) 5 take away 2 is (3) (∅∅○○○)

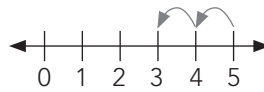

- c) 5 take away 1 is (4) (∅○○○○)

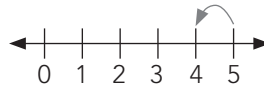

- d) 5 take away 4 is (1) (∅∅∅∅○)

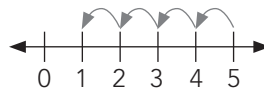

Homework

Draw the following:

- a) 3 and 2 is 5 (●●●○○)
 b) 4 and 1 is 5 (●●●●○)
 c) 5 take away 2 is 3 (∅∅○○○)
 d) 5 take away 1 is 4 (∅○○○○)

LESSON 18: NUMBERS 6 TO 10 – RECOGNITION

Teacher's notes

CAPS topics: 1.2 Count forwards and backwards, 1.16 Mental mathematics, 1.3 Number symbols and number names

Lesson vocabulary: Number symbols 6 to 10 and number names six to ten, more than, less than, in between

Prior knowledge:

Learners should have been taught how to:

- Identify, recognise and read the number symbols 1 to 10 and the number names one to ten.

Concepts:

- Identify, recognise and read number symbols 6 to 10
- Identify, recognise, and read number names six to ten

Resources: Number symbol and number name cards, counting objects, old magazines

DBE workbook activities relevant to this lesson:

- N/A

Assessment: Refer to the tracker for today's formal/informal oral, practical or written assessment activity..

Remediation: Ask the learners to give you objects such as: **six** beads, **seven** shapes, **eight** blocks, **nine** Unifix cubes, and **ten** balls. Learners then build the number symbols 1, 2, 3, 4 and 5 with counters, stones or any other concrete resource available. The learners can be taken outside and can write the number symbols in the sand on the playground. Ask learners to identify each symbol.

Enrichment: See enrichment activity cards – learners can use any cards from the back of this book.

1. Mental mathematics

1.1 Counting (5 minutes)

Learners count from 1–10 using a number board. Learners must point to the numbers as they say them. Ask learners to count on to 10 from different starting points e.g. 3, 7, 5, etc.

1.2 Recall and strategies (10 minutes)

Point to a number on the number board, and ask learners to tell you what number comes before/after it.

In the same way, develop the language of *more than* (point to a number that is more than **3**), *less than* (point to a number that is less than **5**), *the same as* (point to a number that is the same as **3** and **1** added together) and *in between* (point to the number that is in between **1** and **3**), etc.

2. Correction/reflection on homework (15 minutes)

Reflection/remediation based on previous day's work/homework.

3. Lesson content – concept development (30 minutes)

Activity 1: Learners work in groups

- In this activity you could use any objects to count that you have. You do not need to have so many different kinds. You could use one set of ten objects and count out the different numbers one at a time with the learners.
- Place 10 objects on the learners' tables: for example **10** beads, **10** pencils, **10** crayons, **10** counters, **10** Unifix cubes.
- Ask the learners to put out **6** beads, **seven** pencils, **eight** crayons, **nine** counters, **ten** Unifix cubes.
- Ask the learners to draw the beads, pencils, crayons, counters and Unifix cubes.
- Ask: **What can you tell me about 6?** (Allow many different learners to answer and discuss each answer. Encourage learners to come up with different ideas. For example: It is more than **5**/It is **1** less than **7**/It is **4** less than **10**/It is made up of **3** and **3**, etc.)
- Repeat above question for numbers 7, 8, 9 and 10.

Activity 2: Whole class activity

- Point to the number symbols 6, 7, 8, 9 and 10, and tell the learners that this is how we write six/seven/eight/nine/ten as a symbol.

6 7 8 9 10

(**Note:** Learners only need to know the number names up to 5 (one, two, three, four, five) and the number symbols up to 10 (1, 2, 3, 4, 5, 6, 7, 8, 9 and 10).

Activity 3: Whole class activity

- Ask the learners to make an oral sentence with the words six, seven, eight, nine and ten. (E.g. An ant has **six** legs. There are **seven** days in a week. A spider has **eight** legs. There are **nine** cupcakes in a pack. I have **ten** toes.)

4. Classwork activity (25 minutes) (See next page)

5. Homework activity (5 minutes) (See next page)

6. Reflection on lesson

Term 1 Lesson 18: Numbers 6 to 10 – recognition

Classwork

- Count the beads and circle the correct answer.
 - ○○○○○ 6 7 8 9 (10)
 - ○○ 6 (7) 8 9 10
 - ○○○○ 6 7 8 (9) 10
 - ○○○ 6 7 (8) 9 10
 - ○ (6) 7 8 9 10
- Find and cut out numbers 6, 7, 8, 9 and 10 from a magazine.
- Write the numbers in the correct order.
 - 6 8 3 1 9 4 7 10 2 5
(1 2 3 4 5 6 7 8 9 10)

Homework

Count the shapes and write the number symbols

- ♡ (1)
- △△ (2)
- ♡♡♡ (3)
- △△△△ (4)
- ♡♡♡♡♡ (5)
- △△△△△△ (6)
- ♡♡♡♡♡♡♡ (7)
- △△△△△△△△ (8)
- ♡♡♡♡♡♡♡♡ (9)
- △△△△△△△△△△ (10)

LESSON 19: NUMBER PATTERNS TO 10

Teacher's notes

CAPS topics: 1.2 Count forwards and backwards, 1.16 Mental mathematics, 2.2 Number patterns

Lesson vocabulary: Before, after, in between, number patterns, more or less, copy

Prior knowledge:

Learners should have been taught how to:

- Copy and extend simple patterns using physical objects and drawings.
- Count forwards and backwards in ones from any number between 1 and 10.

Concepts:

- Copy, extend and describe simple number sequences to 10

Resources: Number symbol cards (1–10), number picture cards (see *Printable Resources*)

•	• •	• • • •	• • • •	• • • • • •
• • • • • •	• • • • • • • • •	• • • • • • • •	• • • • • • • •	• • • • • • • • • • • •

DBE workbook activities relevant to this lesson:

- N/A

Assessment: Refer to the tracker for today's formal/informal oral, practical or written assessment activity.

Remediation: Give each learner a blank 1–10 number board and number symbol cards to stick in order on the number board. Point to the fifth space on the number board and ask: **How many empty spaces are there up to here on the number board? (5)**. After they have given you the number of spaces, ask learners to take the number 5 symbol and place it on the number board. Repeat with other numbers.

Enrichment: See enrichment activity cards – learners can use any cards from the back of this book.

1. Mental mathematics

1.1 Counting (5 minutes)

Learners count from 1–10 using a number board. Learners must point to the numbers as they say them. Ask learners to count on to 10 from different starting points, e.g. 3, 7, 5, etc. Learners count from 10–1 using the number board.

1.2 Recall and strategies (10 minutes)

Point to a number on the number board, and ask learners to tell you what number comes *before/after* it. In the same way, develop the language of *more than* (point to a number that is more than **3**), *less than* (point to a number that is less than 5), *the same as* (point to a number that is the same as 3 and 1 added together) and *in between* (point to the number that is in between 1 and 3), etc.

2. Correction/reflection on homework (15 minutes)

Reflection/remediation based on previous day's work/homework.

3. Lesson content – concept development (30 minutes)

Activity 1: Learners work in groups

- Give learners the number picture cards.
- Ask learners to place them in order starting from 1.
- Ask: **What number comes before 5? What number comes after 5? What number is between 3 and 5?** (Learners must use the vocabulary *before*, *after* and *in between* in their responses.)

Activity 2: Learners work in groups

- Give learners a set of number symbol cards.
- Ask learners to shuffle the number cards and remove one.
- Ask the learners to place the cards in order.
- Ask the learners which card is missing. (E.g. 1, 2, 3, 5, 6, 7, 8, 9, 10 ... 4 is missing.)
- Do this a few times, with different cards taken out of the pack.

Activity 3: Whole class activity

- Draw a blank table with one row and 10 blocks on the scrap paper/whiteboards.
- Stick the number symbol cards randomly on the board.
- Refer to your empty row of ten blocks (1–10 number board). Explain that you are going to place the numbers in the correct order on the table.

--	--	--	--	--	--	--	--	--	--

- Stick a few numbers in some of the blocks.

			4	5				9	
--	--	--	---	---	--	--	--	---	--

- Ask the learners to come and place the other numbers in the correct boxes.
- Ask learners questions such as:
 - **How did you know where to stick the 6?** (6 comes after 5)
 - **How did you know where to stick the 3?** (3 comes before 4)
 - **How did you know where to stick the 8?** (8 comes before 9)
 - **How did you know where to stick the 10?** (10 comes after 9)
- Repeat with different starting numbers as time allows.

4. Classwork activity (25 minutes) (See next page)

5. Homework activity (5 minutes) (See next page)

6. Reflection on lesson

Term 1 Lesson 19: Number patterns to 10

Classwork

1. Fill in the missing numbers.

a)	<table border="1"><tr><td>2, 3, □ (4), □ (5)</td></tr></table>	2, 3, □ (4), □ (5)	b)	<table border="1"><tr><td>□ (1), □ (2), 3, 4</td></tr></table>	□ (1), □ (2), 3, 4	c)	<table border="1"><tr><td>1, □ (2), 3, □ (4)</td></tr></table>	1, □ (2), 3, □ (4)
2, 3, □ (4), □ (5)								
□ (1), □ (2), 3, 4								
1, □ (2), 3, □ (4)								
d)	<table border="1"><tr><td>(1) □, 2, 3, □ (4)</td></tr></table>	(1) □, 2, 3, □ (4)	e)	<table border="1"><tr><td>2, □ (3), □ (4), 5</td></tr></table>	2, □ (3), □ (4), 5	f)	<table border="1"><tr><td>2, 3, □ (4), □ (5)</td></tr></table>	2, 3, □ (4), □ (5)
(1) □, 2, 3, □ (4)								
2, □ (3), □ (4), 5								
2, 3, □ (4), □ (5)								

2. Fill in the missing number/s.

a)	<table border="1"><tr><td>4</td><td>(5)</td><td>6</td></tr></table>	4	(5)	6	b)	<table border="1"><tr><td>2</td><td>(3)</td><td>4</td></tr></table>	2	(3)	4	c)	<table border="1"><tr><td>(6)</td><td>7</td><td>(8)</td></tr></table>	(6)	7	(8)
4	(5)	6												
2	(3)	4												
(6)	7	(8)												
d)	<table border="1"><tr><td>7</td><td>(8)</td><td>9</td></tr></table>	7	(8)	9	e)	<table border="1"><tr><td>(5)</td><td>6</td><td>(7)</td></tr></table>	(5)	6	(7)	f)	<table border="1"><tr><td>8</td><td>(9)</td><td>10</td></tr></table>	8	(9)	10
7	(8)	9												
(5)	6	(7)												
8	(9)	10												

3. Fill in the missing numbers in the empty boxes.

a)	<table border="1"><tr><td>0</td><td>1</td><td>2</td><td>3</td><td>(4)</td><td>(5)</td><td>(6)</td><td>7</td><td>(8)</td><td>(9)</td></tr></table>	0	1	2	3	(4)	(5)	(6)	7	(8)	(9)
0	1	2	3	(4)	(5)	(6)	7	(8)	(9)		
b)	<table border="1"><tr><td>1</td><td>(2)</td><td>(3)</td><td>4</td><td>(5)</td><td>(6)</td><td>(7)</td><td>(8)</td><td>(9)</td><td>10</td></tr></table>	1	(2)	(3)	4	(5)	(6)	(7)	(8)	(9)	10
1	(2)	(3)	4	(5)	(6)	(7)	(8)	(9)	10		

Homework

1. Complete the following

- a) 1, 2, 3, (4), (5), 6
- b) 4, (5), 6, (7), 8, (9), 10
- c) 1, (2), (3), (4), 5, (6), (7), (8), (9), 10

LESSON 20: NUMBERS 11 TO 15 – RECOGNITION

Teacher's notes

CAPS topics: 1.2 Count forwards and backwards, 1.16 Mental mathematics, 1.3 Number symbols and number names

Lesson vocabulary: Number symbols 11 to 15 and number names eleven to fifteen, bigger than, smaller than, more than

Prior knowledge:

Learners should have been taught how to:

- Identify, recognise and read the number symbols 1 to 10.
- Identify, recognise, read and write the number symbols 1 to 5 and the number names one to five.
- Identify, recognise and read the number symbols 6 to 10.

Concepts:

- Count forwards and backwards in ones from any number between 1 and 10
- Compare numbers 10 and say which is more or less
- Identify, recognise, and read number symbols 11 to 15

Resources: Number symbol and number name cards, counting objects, old magazines/newspapers

DBE workbook activities relevant to this lesson:

- N/A

Assessment: Refer to the tracker for today's formal/informal oral, practical or written assessment activity.

Remediation: Ask the learners to use their Unifix cubes to show: eleven, twelve, thirteen, fourteen, fifteen. Take the learners outside and write the number symbols in the sand.

Enrichment: See enrichment activity cards – learners can use any cards from the back of this book.

1. Mental mathematics

1.1 Counting (5 minutes)

Learners use a number board to count forwards and backwards in ones to a maximum of 20. Ask learners to start at different numbers and count on from there.

1.2 Recall and strategies (10 minutes)

Give learners 1–5 number cards. Tell the learners to arrange the cards in order from the smallest to the biggest and from the biggest to the smallest. Ask the learners: **Which is more: 2 or 3?** (3) **What can you tell me about 4 and 5?** (5 is bigger than 4/4 is smaller than 5) **Which is less: 3 or 2?** (2), etc.

2. Correction/reflection on homework (15 minutes)

Reflection/remediation based on previous day's work/homework.

3. Lesson content – concept development (30 minutes)

Activity 1: Learners work in groups

- Place a string of beads or counters on the learners' tables.
- Ask each learner to count to 11 using the beads/counters.
- Ask: **What can you tell me about the number 11?** (Allow many different learners to answer and discuss each answer. Encourage learners to come up with different ideas. For example: **11 is bigger than 10; 11 is smaller than 12; 11 is 2 more than 9**, etc.).
- Ask learners to use their beads/counters to show you what they notice about 11. (Demonstrate similar ideas, e.g. **11 is 1 bigger than 10**, etc. using beads and counters.)
- **Note:** Learners are encouraged to move their beads/counters to investigate the number 11 (e.g. ●●●●●●●●●●/●●●●● ●●●●●/● ● ● ● ● ● ● ● ● ●, etc.). Do not teach them specific number facts here.
- Let them discuss what they notice in pairs.
- Do the same with 12, 13, 14 and 15.

Activity 2: Whole class activity

- Stick the number symbol and number name cards on the board.
- Point to the number symbols 11, 12, 13, 14 and 15.
- Explain to the learners that this is how we write eleven, twelve, thirteen, fourteen and fifteen as a symbol.
- Give learners magazines or newspapers and ask them to find the number symbols 11, 12, 13, 14 and 15.

4. Classwork activity (25 minutes) (See next page)

5. Homework activity (5 minutes) (See next page)

6. Reflection on lesson

Term 1 Lesson 20: Numbers 11 to 15 – recognition

Classwork

1. Count the Unifix cubes and colour the correct answer.

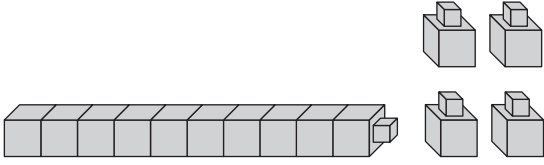
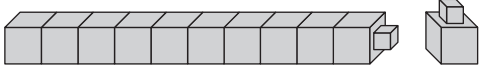
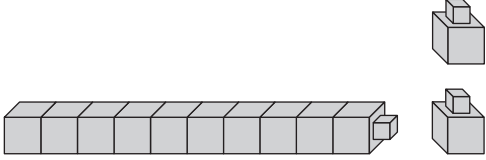
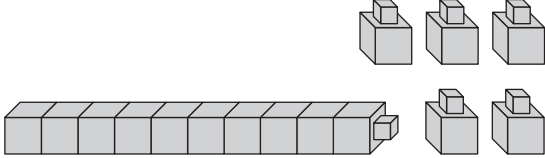
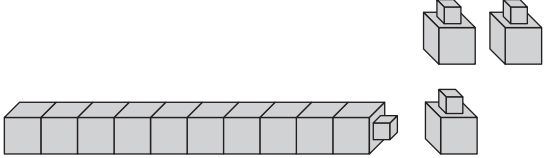
<p>a) </p> <table border="1" style="width: 100%; text-align: center; border-collapse: collapse;"> <tr> <td>(10)</td> <td>11</td> <td>12</td> <td>13</td> <td>14</td> <td>15</td> </tr> </table>	(10)	11	12	13	14	15	<p>b) </p> <table border="1" style="width: 100%; text-align: center; border-collapse: collapse;"> <tr> <td>10</td> <td>11</td> <td>12</td> <td>13</td> <td>(14)</td> <td>15</td> </tr> </table>	10	11	12	13	(14)	15
(10)	11	12	13	14	15								
10	11	12	13	(14)	15								
<p>c) </p> <table border="1" style="width: 100%; text-align: center; border-collapse: collapse;"> <tr> <td>10</td> <td>(11)</td> <td>12</td> <td>13</td> <td>14</td> <td>15</td> </tr> </table>	10	(11)	12	13	14	15	<p>d) </p> <table border="1" style="width: 100%; text-align: center; border-collapse: collapse;"> <tr> <td>10</td> <td>11</td> <td>(12)</td> <td>13</td> <td>14</td> <td>15</td> </tr> </table>	10	11	(12)	13	14	15
10	(11)	12	13	14	15								
10	11	(12)	13	14	15								
<p>e) </p> <table border="1" style="width: 100%; text-align: center; border-collapse: collapse;"> <tr> <td>10</td> <td>11</td> <td>12</td> <td>13</td> <td>14</td> <td>(15)</td> </tr> </table>	10	11	12	13	14	(15)	<p>f) </p> <table border="1" style="width: 100%; text-align: center; border-collapse: collapse;"> <tr> <td>10</td> <td>11</td> <td>12</td> <td>(13)</td> <td>14</td> <td>15</td> </tr> </table>	10	11	12	(13)	14	15
10	11	12	13	14	(15)								
10	11	12	(13)	14	15								

2. Find and cut out numbers 11, 12, 13, 14 and 15 from a magazine or newspaper.

3. Write the numbers in the correct order.

6 14 8 11 9 10 15 7 13 12
 (6 7 8 9 10 11 12 13 14 15)

Homework

1. Count the counters and write the correct answer.

<p>a) ○○○○ ○○○○ ○○○</p> <table border="1" style="width: 100%; text-align: center; border-collapse: collapse;"> <tr> <td>10</td> <td>(11)</td> <td>12</td> <td>13</td> <td>14</td> <td>15</td> </tr> </table>	10	(11)	12	13	14	15	<p>b) ○○○○ ○○○○ ○○○○○○</p> <table border="1" style="width: 100%; text-align: center; border-collapse: collapse;"> <tr> <td>10</td> <td>11</td> <td>12</td> <td>13</td> <td>14</td> <td>(15)</td> </tr> </table>	10	11	12	13	14	(15)
10	(11)	12	13	14	15								
10	11	12	13	14	(15)								
<p>c) ○○○○ ○○○○ ○○○○○</p> <table border="1" style="width: 100%; text-align: center; border-collapse: collapse;"> <tr> <td>10</td> <td>11</td> <td>12</td> <td>(13)</td> <td>14</td> <td>15</td> </tr> </table>	10	11	12	(13)	14	15	<p>d) ○○○○ ○○○○ ○○ ○○○○</p> <table border="1" style="width: 100%; text-align: center; border-collapse: collapse;"> <tr> <td>10</td> <td>11</td> <td>12</td> <td>13</td> <td>(14)</td> <td>15</td> </tr> </table>	10	11	12	13	(14)	15
10	11	12	(13)	14	15								
10	11	12	13	(14)	15								
<p>e) ○○○○ ○○○○ ○○○○</p> <table border="1" style="width: 100%; text-align: center; border-collapse: collapse;"> <tr> <td>10</td> <td>11</td> <td>(12)</td> <td>13</td> <td>14</td> <td>15</td> </tr> </table>	10	11	(12)	13	14	15							
10	11	(12)	13	14	15								

WEEK 7

LESSON 21: PATTERNS OF 10

Teacher's notes

CAPS topics: 1.16 Mental mathematics, 2.2 Number patterns

Lesson vocabulary: Number symbols 1 to 20, number line, backwards, forwards, between, lower number, higher number

Prior knowledge:

Learners should have been taught how to:

- Copy and extend simple patterns using physical objects and drawings.
- Identify and read number symbols 1 to 15 and compare and order them.

Concepts:

- Copy, extend and describe simple number sequences 1 to 20, i.e. count forwards and backwards in ones from 1 to 20

Resources: Number lines, number boards, counters, number symbol cards (1–20)

DBE workbook activities relevant to this lesson:

- N/A

Assessment: Refer to the tracker for today's formal/informal oral, practical or written assessment activity.

Remediation: Give the learners a number board with numbers 0 to 20 written on it. Ask them to place one counter at a time on the number board while counting. Count forwards from 1 to 20. Then count backwards from 20 to 0 while removing one counter at a time.

Enrichment: See enrichment activity cards – learners can use any cards from the back of this book.

1. Mental mathematics

1.1 Counting (5 minutes)

Learners order a set of familiar numbers and place them on a number line.

1.2 Recall and strategies (10 minutes)

Write numbers 1 to 5 on the board. Ask the learners which number is: 1 more, 2 more, 1 less, 2 less.

2. Correction/reflection on homework (15 minutes)

Reflection/remediation based on previous day's work/homework.

3. Lesson content – concept development (30 minutes)

Activity 1: Whole class activity

- Draw a 0–10 number line on the board with only the 0 and the 10 filled in.
- Ask: **What can you tell me about what you see?** (0 is a *lower* number/10 is a *higher* number/There is no number 5, etc.)
- Ask the learners to count the spaces on the number line by filling in the spaces with counters.
- Ask learners to touch and count forwards from the 0 and stop at 10.
- Ask learners to count backwards from 10 to 0.
- Ask: **What numbers come between 0 and 10?** (1, 2, 3, 4, 5, 6, 7, 8, 9)
- Ask the learners to fill in the missing numbers using number symbol cards.

Activity 2: Whole class activity

- Draw and label a 10–20 number line on the board with some numbers missing.



- Discuss what numbers are missing.
- Ask some learners to come to the board and touch and count forwards from the 10 and stop at 20.
- Ask other learners to count backwards from 20 to 10.
- Allow some of the learners to fill in the missing numbers on the number line using number symbol cards.

Activity 3: Optional

- Ask the learners to draw a 0–15 number line into their books.
- Learners should label all the markers on the number line.



- Learners work in pairs counting using their number lines. (They could experiment with counting in different ways. For example, Start at zero and count in twos pointing to the even numbers on the number line; Start at 1 and count in twos pointing to the odd numbers on the number line; etc.)

4. Classwork activity (25 minutes) (See next page)

5. Homework activity (5 minutes) (See next page)

6. Reflection on lesson

Term 1 Lesson 21: Patterns of 10

Classwork

1. Complete the number line by filling in the missing numbers.

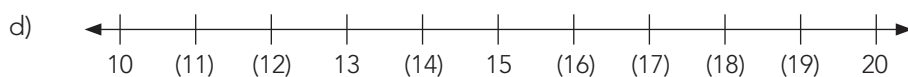
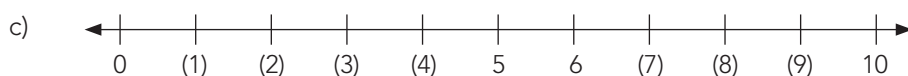
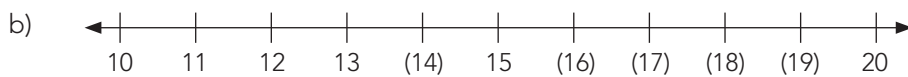
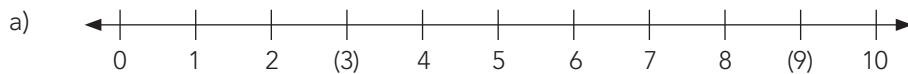

Homework

1. Complete the number lines by filling in the missing numbers.

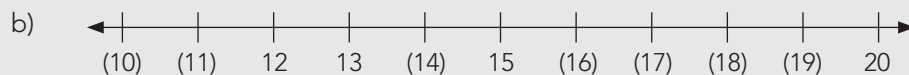
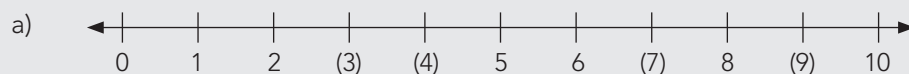

LESSON 22: NUMBERS 16 TO 20 – RECOGNITION

Teacher's notes

CAPS topics: 1.16 Mental mathematics, 1.3 Number symbols and number names

Lesson vocabulary: Order, number symbols 16 to 20 and number names sixteen to twenty, bigger than, less than

Prior knowledge:

Learners should have been taught how to:

- Identify, recognise read and write number symbols 1 to 5 and number names one to five.
- Identify, recognise and read number symbols 1 to 15.

Concepts:

- Order a given set of selected numbers
- Identify, recognise and read number symbols 16 to 20

Resources: Number symbol and number name cards, counting objects, old magazines/newspapers

DBE workbook activities relevant to this lesson:

- N/A

Assessment: Refer to the tracker for today's formal/informal oral, practical or written assessment activity.

Remediation: Ask the learners to use their Unifix cubes to show: sixteen, seventeen, eighteen, nineteen, and twenty. Take the learners outside, and write the number symbols in the sand.

Enrichment: See enrichment activity cards – learners can use any cards from the back of this book.

1. Mental mathematics

1.1 Counting (5 minutes)

Learners use a number line to count forwards and backwards in ones to a maximum of 20. Ask learners to start at different numbers and count on from there.

1.2 Recall and strategies (10 minutes)

Give each learner **10** beads on a string. Ask the learners to separate some of the beads by using their fingers. Ask them to explain what they see (**3** beads and **7** beads make **10** beads/**1** bead and **9** beads make **10** beads).

2. Correction/reflection on homework (15 minutes)

Reflection/remediation based on previous day's work/homework.

3. Lesson content – concept development (30 minutes)

Activity 1: Learners work in groups

- Place a string of beads or counters on the learners' tables.
- Ask each learner to count to 16 using the beads/counters.
- Ask: **What can you tell me about the number 16?** (Allow many different learners to answer and discuss each answer. Encourage learners to come up with different ideas. For example: It is *bigger than 15*/It is *less than 17*/It is four away from **20**)
- Ask learners to use their beads/counters to show you what they notice about 16. (Ask learners to use their beads/counters to show you what they notice about 16 as in lesson 19.)
- **Note:** Learners are encouraged to move their beads/counters to investigate the number 16 (e.g. ●●●●●●●● ●●●●●●●●●● ●● ●● ●● ●● ●● ●● ●● ●● ●●●●●●●●●●●●●●●●, etc.). Do not teach them specific number facts here.
- Let them discuss what they notice in pairs.
- Repeat with 17, 18, 19 and 20.

Activity 2: Whole class activity

- Stick the number symbol and number name cards on the board.
- Point to the number symbols 16, 17, 18, 19 and 20.
- Tell the learners this is how we write sixteen, seventeen, eighteen, nineteen and twenty as a symbol.
- Give learners old magazines or newspapers, and ask them to find the number symbols 16, 17, 18, 19 and 20.

4. Classwork activity (25 minutes) (See next page)

5. Homework activity (5 minutes) (See next page)

6. Reflection on lesson

Term 1 Lesson 22: Numbers 16 to 20 – recognition

Classwork

1. Count the Unifix cubes and colour the correct answer.

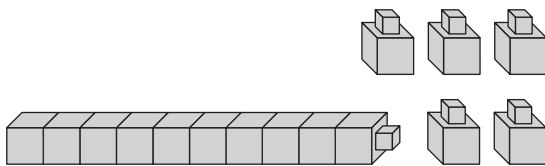
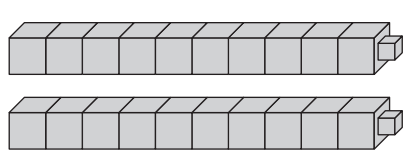
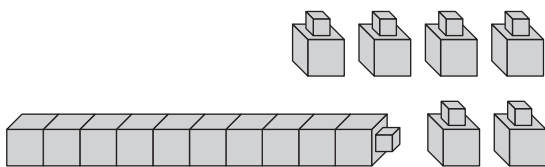
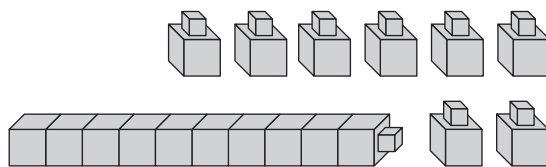
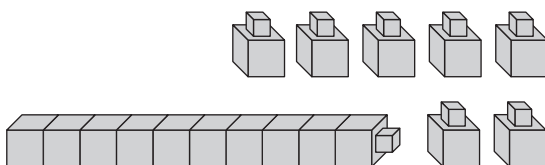
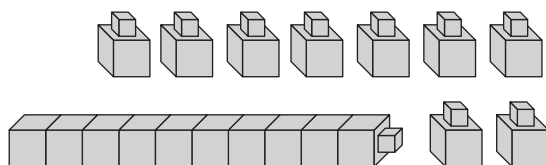
<p>a)</p>  <p>(15) 16 17 18 19 20</p>	<p>b)</p>  <p>15 16 17 18 19 (20)</p>
<p>c)</p>  <p>15 (16) 17 18 19 20</p>	<p>d)</p>  <p>15 16 17 (18) 19 20</p>
<p>e)</p>  <p>15 16 (17) 18 19 20</p>	<p>f)</p>  <p>15 16 17 18 (19) 20</p>

2. Find and cut out numbers 16, 17, 18, 19 and 20 from a magazine or newspaper.
(Learners follow the instructions.)

Homework

Count the counters and write the correct answer.

- | | |
|---------------------------|----------------------|
| a) ○○○○○○○○○○○○○○○○○○○ | (16), 17, 18, 19, 20 |
| b) ○○○○○○○○○○○○○○○○○○○○ | 16, (17), 18, 19, 20 |
| c) ○○○○○○○○○○○○○○○○○○○○○ | 16, 17, 18, (19), 20 |
| d) ○○○○○○○○○○○○○○○○○○○○○ | 16, 17, (18), 19, 20 |
| e) ○○○○○○○○○○○○○○○○○○○○○○ | 16, 17, 18, 19, (20) |

LESSON 23: NUMBER PATTERNS 1 TO 15

Teacher's notes

CAPS topics: 1.16 Mental mathematics, 1.3 Number symbols and number names

Lesson vocabulary: Number symbol, number name, before, after, below, above, number pattern, compare, order, left, right, bottom, top

Prior knowledge:

Learners should have been taught how to:

- Identify, recognise read and write number symbols 1 to 5 and number names one to five.
- Identify, recognise and read number symbols 1 to 15.

Concepts:

- Copy, extend and describe simple number sequences 1 to 20, i.e. count forwards and backwards in ones from 1 to 20

Resources: Number symbol cards (0 to 15), vertical and horizontal number boards (prepare before the lesson)

DBE workbook activities relevant to this lesson:

- N/A

Assessment: Refer to the tracker for today's formal/informal oral, practical or written assessment activity.

Remediation: Give the learners the 1–10 cards. Ask them to place the 2, 3 and 4 side by side in sequence on the table. Then ask them to find the correct cards before and after these numbers and to place them in the sequence. Ask the learners to place the 3 card on the table, with the 4 and 5 cards in sequence above it. Then ask them to place the correct cards below and above these. Do a few examples like this.

Enrichment: See enrichment activity cards – learners can use any cards from the back of this book.

1. Mental mathematics

1.1 Counting (5 minutes)

Learners use a number line to count forwards and backwards in ones to a maximum of 20. Ask learners to start at different numbers and count on from there.

1.2 Recall and strategies (10 minutes)

Ask learners to show you a number that is smaller than 10. Learners write the number on their scrap paper/whiteboards and hold them up for you to see. Repeat with other numbers.

2. Correction/reflection on homework (15 minutes)

Reflection/remediation based on previous day's work/homework.

3. Lesson content – concept development (30 minutes)

Activity 1: Whole class activity

- If you have prepared number boards for this activity use them. If you did not have a chance you should draw the two number boards shown below on the board to refer to during this activity.
- Give learners the 1–10 vertical number board (if possible). Ask the learners to touch and count the blocks from 1 to 10 while reading the number symbols.
- Give learners a horizontal 1–10 board, and ask them to touch and count the blocks from 1 to 10 while reading the number symbols.
- Then give the learners horizontal and vertical boards with missing numbers and loose number cards. Ask the learners to fill in the missing numbers with the loose number symbol cards (or do this on the board).

10
9
8
7
6
5
4
3
2
1

1	2	3	4	5	6	7	8	9	10
---	---	---	---	---	---	---	---	---	----

Activity 2: Learners work in groups

- Give the learners the loose 1 to 15 cards.
- Ask learners to place them randomly on their tables.
- Then ask learners to place the cards in the correct order from the smallest to the biggest (from left to right).
- Ask the learners to place the cards in order from the smallest to the biggest (from the bottom to the top of their tables).
- Repeat the above two steps, but ask learners to order the cards from the biggest to the smallest this time.

4. Classwork activity (25 minutes) (See next page)

5. Homework activity (5 minutes) (See next page)

6. Reflection on lesson

Term 1 Lesson 23: Number patterns 1 to 15

Classwork

1. Fill in the missing numbers.

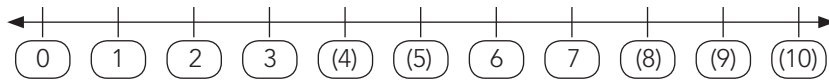

2. Fill in the missing numbers.

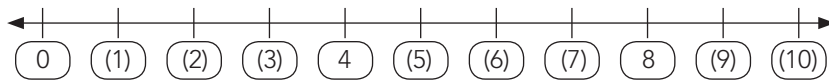

3. Choose numbers from 1–15, and write them in different colours to make a pattern on each number line. (Learners will produce various number patterns.)



Homework

1. Fill in the missing numbers:

a)	5	(6)	(7)	(8)	(9)	10	(11)	(12)	(13)	(14)	15
b)	1	2	(3)	(4)	5	(6)	(7)	8	(9)	(10)	11
c)	2	(3)	(4)	(5)	(6)	7	(8)	(9)	(10)	11	(12)

LESSON 24: 3-D – BALLS AND BOXES

Teacher's notes

CAPS topics: 1.1 Count objects, 1.16 Mental mathematics, 3.2 3-D objects

Lesson vocabulary: Ball shapes, box shapes, 3-D objects

Prior knowledge:

Learners should have been taught how to:

- Recognise and name 3-D objects in the classroom and in pictures

Concepts:

- Recognise and name 3-D objects in the classroom and in pictures

Resources: Number symbol cards (0–5), round pebbles, marbles, oranges, balls (various sizes), blocks, bricks, boxes (various sizes) and ball pictures, objects, a picture of a classroom

DBE workbook activities relevant to this lesson:

- DBE worksheet 23 (pp. 48 and 49)

Assessment: Refer to the tracker for today's formal/informal oral, practical or written assessment activity.

Remediation: Give groups of learners objects that look like balls and boxes. Ask learners to sort them into two piles – one of boxes and one of balls.

Enrichment: See enrichment activity cards – learners can use any cards from the back of this book.

1. Mental mathematics

1.1 Counting (5 minutes)

Introduce learners to numbers by using number rhymes, songs and games. (Use previous examples.)

1.2 Recall and strategies (10 minutes)

Give learners 1–5 number cards. Ask them to order them from 1 to 5 and then from 5 to 1. Ask questions to get learners to use the vocabulary of *more than* and *less than*.

2. Correction/reflection on homework (15 minutes)

Reflection/remediation based on previous day's work/homework.

3. Lesson content – concept development (30 minutes)

In this lesson it is important that you do the activities with both the objects and the pictures of objects. You should allow learners to hold and examine the objects before you move onto the activity in which they look at pictures. This is because the objects are concrete and the pictures are semi-concrete – learners should always experience examples of concrete shapes before they look at 2-D flat pictures and 2-D diagrams of the same shapes. Speak to learners about the difference between ball and box shapes – show them how ball shapes can roll and box shapes can slide. This is an important first step in classifying spheres (ball shapes) and prisms (box shapes).

Activity 1: Learners will work in groups

- Give learners some ball-shaped objects, such as round pebbles, marbles, oranges and balls of different sizes.
- Give learners some box-shaped objects, such as blocks, bricks and boxes of different sizes.
- Ask the learners to show you the: *ball*-shaped objects and then the *box*-shaped objects.

Activity 2: Whole class activity

- Place some box-shaped and ball-shaped objects in your classroom, and ask learners to identify them.
- Ask questions like: **Is this a ball-shaped object or a box-shaped object?**
- **What makes you say that this is a ball-shaped/box shaped object?**

Activity 3: Whole class activity

- Give each group a few pictures of box and ball shapes and ask learners to identify them.
- Ask learners to sort the pictures.
- Ask: **How did you sort your pictures? Why did you sort your pictures that way?**
- **Is there another way to sort the pictures?** (Encourage learners to verbalise their reasoning, and in so doing, to distinguish between *ball*-shaped and *box*-shaped objects.) Ask questions like: **Is this a ball-shaped object or a box-shaped object?**
- **What makes you say that this is a ball-shaped/box shaped object?** Remind them about the difference between ball and box shapes – show them how ball shapes can roll and box shapes can slide. Let them talk about the kinds of surfaces the two different kinds of shapes have (round/flat).

4. **Classwork activity (25 minutes) (See next page)**

5. **Homework activity (5 minutes) (See next page)**

6. **Reflection on lesson**

Term 1 Lesson 24: 3-D – balls and boxes

Classwork

1. Look around the classroom.
2. Draw 5 ball-shaped objects.
(Learners will draw the pictures to match the instructions.)
3. Draw 5 box-shaped objects.
(Learners will draw the pictures to match the instructions.)
4. Label the pictures 'ball' or 'box'.

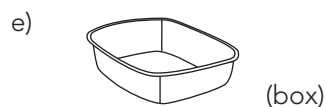
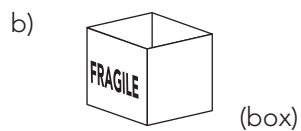

Homework

1. Look around your home.
2. Find one ball-shaped object and one box-shaped object.
3. Draw the two objects in your homework book, and label each picture 'ball' or 'box'. (Learners will draw the pictures to match the instructions.)

WEEK 8

LESSON 25: SIZE OF 3-D OBJECTS

Teacher's notes

CAPS topics: 1.1 Count objects, 1.16 Mental mathematics, 3.2 3-D objects

Lesson vocabulary: Big, small, bigger than, smaller than, medium, 3-D objects, sort and compare size, more than, less than and the same as, describe, sort, compare, middle, left, right

Prior knowledge:

Learners should have been taught how to:

- Recognise and name 3-D objects in the classroom.
- Describe, sort and compare objects in terms of size.

Concepts:

- Recognise and name 3-D objects in the classroom and in pictures
- Describe, sort and compare 3-D objects in terms of size

Resources: Pictures of objects of various sizes (e.g. an elephant, a mouse, a large tree, balls, boxes), balls and boxes of various sizes

DBE workbook activities relevant to this lesson:

- DBE worksheet 27 (pp. 58 and 59)

Assessment: Refer to the tracker for today's formal/informal oral, practical or written assessment activity.

Remediation: Place a small, medium and big ball on your desk. Show them the ball when you ask the question:

Show me a ball smaller than this one/Show me a ball bigger than this one.

Do the same with boxes.

Enrichment: See enrichment activity cards – learners can use any cards from the back of this book.

1. Mental mathematics

1.1 Counting (5 minutes)

Introduce learners to numbers by using number rhymes, songs and games. (Use previous examples.)

1.2 Recall and strategies (10 minutes)

Give each learner 1–5 number cards. Ask them to choose one card. Then ask: **Give me a number that is two more** and **Give me a number that is two less. What can you tell me about this number?** Learners must use the language of *more than*, *less than* and *the same as* and also describe numbers as (e.g. **3 is 3 more than 0**).

2. Correction/reflection on homework (15 minutes)

Reflection/remediation based on previous day's work/homework.

3. Lesson content – concept development (30 minutes)

Once learners start to become familiar with the names of 3-D objects they start to learn about the characteristics of these objects. In this lesson learners focus on the size of the objects and get involved in activities where they compare the sizes of different objects in order to highlight the characteristic of "size".

Activity 1: Learners work in groups

- Give the learners boxes and balls of different sizes.
- Ask the learners to hold up a ball *smaller than* the one you are holding up in your hand.
- Ask the learners to hold up a ball *bigger than* the one you are holding up in your hand.
- Ask the learners to hold up a box *smaller than* the one you are holding up in your hand.
- Ask the learners to hold up a box *bigger than* the one you are holding up in your hand.

Activity 2: Whole class activity

- Refer to the pictures that you have prepared to bring to the lesson. The questions that you ask should relate to the pictures that you found. The questions below are exemplars that you can adapt to the pictures that you found.
- Ask learners questions such as:
 - **What can you tell me about:**
 - **the tree and the mouse?** (The tree is *bigger than* the mouse/the mouse is *smaller than* the tree.)
 - **the elephant and the tree?** (The tree is *bigger than* the elephant/the elephant is *smaller than* the tree.)
 - **What is smaller than the: elephant/tree/etc.?**
 - **Can you give me an example of something smaller than a: tree/mouse/elephant?**
 - **Can you give me an example of something bigger than a: tree/mouse/elephant?**

Activity 3: Learners work in pairs

- In this activity three position words are revised. Make sure that learners are able to understand and use these words as they do the activity.
- Ask learners to draw an object of their choosing *in the middle* of their scrap paper/whiteboards.
- Ask learners to draw a smaller object *on the left* of their first drawing.
- Ask learners to draw a bigger object *on the right* of their first drawing.
- Learners can then discuss their pictures with learners sitting near them by using the appropriate vocabulary (e.g. **My triangle is bigger than my flower, but my sun is bigger than my triangle.**)

4. Classwork activity (25 minutes) (See next page)

5. Homework activity (5 minutes) (See next page)

6. Reflection on lesson

Term 1 Lesson 25: Size of 3-D objects

Classwork

1. Write the sentences using the correct word.



- a) A bicycle is bigger/smaller than an aeroplane. (smaller)
- b) A cat is bigger/smaller than a bicycle. (smaller)
- c) An aeroplane is bigger/smaller than a cat. (bigger)
- d) Draw a bigger object on the right-hand side. (Various drawings)

2. Draw a big ball and a bigger ball. (Various drawings)

3. Draw a big box and a bigger box. (Various drawings)

4. Draw a small box and a smaller box. (Various drawings)

5. Draw a small ball and a smaller ball. (Various drawings)

6. Is the smaller ball on the left or on the right?

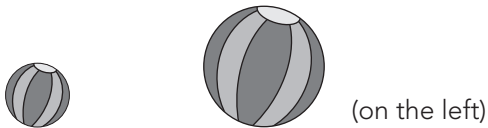

Homework

1. Is the bigger box on the left or on the right?

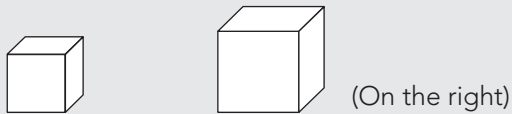

2. Draw 3 animals. (Various drawings)

3. Label the animals 'small', 'bigger' and 'biggest'.

(Learners will label the drawings.)

LESSON 26: 3-D – BUILDING OBJECTS

Teacher's notes

CAPS topics: 1.16 Mental mathematics, 3.2 3-D objects

Lesson vocabulary: Balls, boxes, balance, compare, 3-D objects (3 Dimensional objects), tallest, shortest, biggest, round, flat

Prior knowledge:

Learners should have been taught how to:

- Use 3-D objects such as building blocks and recycled material to construct composite objects like towers and bridges.

Concepts:

- Observe and build given 3-D objects using concrete materials

Resources: Lots of empty matchboxes, glue, objects, balls, boxes, recycled materials

DBE workbook activities relevant to this lesson:

- DBE worksheet 31 (pp. 66 and 67)

Assessment: Refer to the tracker for today's formal/informal oral, practical or written assessment activity.

Remediation: Give each group **10** matchboxes, and ask the learners to build a tower. Encourage them to think of different ways of making a tower by asking questions such as: **Who can make the tallest tower using all the boxes? Who can make the shortest tower using all the boxes? How can you make your tower look more interesting?**

Enrichment: See enrichment activity cards – learners can use any cards from the back of this book.

1. Mental mathematics

1.1 Counting (5 minutes)

Learners use a number board to count forwards and backwards in ones to a maximum of 20. Ask learners to start at different numbers and count on from there.

1.2 Recall and strategies (10 minutes)

Write numbers 1 to 5 on the board. Ask: **Which is more: 2 or 3? (3). What can you tell me about 4 and 5? (4 is less than 5/5 is more than 4). Which is less: 3 or 2? (2), etc.**

2. Correction/reflection on homework (15 minutes)

Reflection/remediation based on previous day's work/homework.

3. Lesson content – concept development (30 minutes)

In this lesson learners focus on the nature of the shape in terms of its sides – are they flat or are they round? These characteristics are highlighted thought thinking about whether or not you can build a tower using given shapes. The round shapes cannot balance. It is important that you allow learners time to build towers of their own so that they consolidate the ideas of round and flat.

Activity 1: Learners work in groups

- **This activity will depend on the resources you have available.**
- Give the learners some balls and boxes.
- Ask them to build a tower in their groups.
- Ask: **What can you tell me about the objects?** (The balls are *round*/The boxes have *flat sides*, etc.)
- Ask: **Were you able to use all the objects? to build a tower? Why not?** (Learners should realise that you cannot balance all shapes on top of each other. The round shapes cannot balance.)
- What did you do with the leftover objects? (Learners may have had different ideas here – encourage them to think freely and creatively.)

Activity 2: Whole class activity

- Build a tower of boxes, with the biggest box at the bottom and the smallest box at the top.
- Ask learners to copy your model with their own boxes.
- Ask: **What do you notice about this tower?** (Encourage learners to discuss the features of the boxes that allow them to balance.)
- Repeat with other models.

Activity 3: Learners work in pairs

- Allow the learners to use the resources to create their own models independently.

4 Classwork activity (25 minutes) (See next page)

5. Homework activity (5 minutes) (See next page)

6. Reflection on lesson

Term 1 Lesson 26: 3-D – building objects

Classwork

1. Can you build a tower with all of the following objects? Write yes or no.

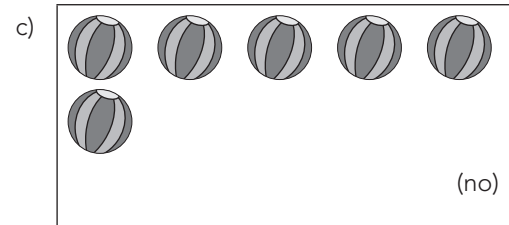
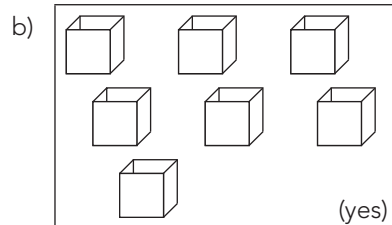
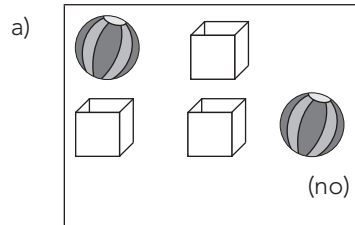

2. Will the tower stand? Write yes or no.

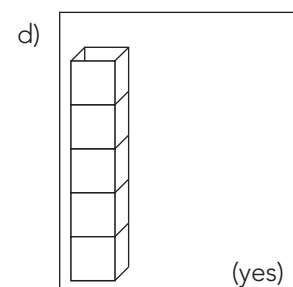
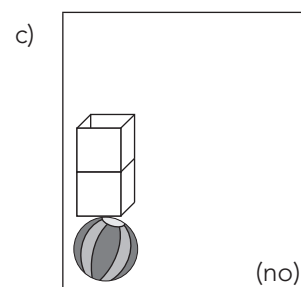
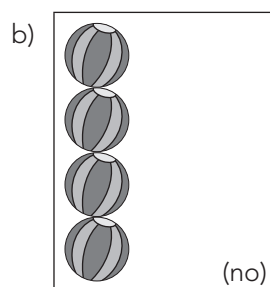
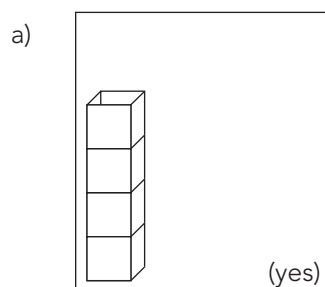

3. Use ten matchboxes and glue to make your own building.
(Learners will follow instructions.)

Homework

1. Collect boxes and balls at home.
2. Build your own tower (or other shape). (Learners will follow instructions.)
3. What shape did you build? (Learners will respond to the question.)
4. Bring it to school to show your teacher. (Learners will follow instructions.)

LESSON 27: LENGTH

Teacher's notes

CAPS topics: 1.1 Count objects, 1.16 Mental mathematics, 4.2 Length

Lesson vocabulary: Length, long, short, longer than, shorter than, taller than, wider than, narrower than, thicker, thinner, high, low, higher than, lower than, tallest, shortest

Prior knowledge:

Learners should have been taught how to:

- Compare and order the length, height or width of two or more objects by placing them next to each other.
- Use language to talk about the comparison.

Concepts:

- Compare and order the length, height or width of two or more objects by placing them next to each other
- Use language to talk about the comparison

Resources: Number symbol cards, pencils, sticks, Unifix cubes

DBE workbook activities relevant to this lesson:

- DBE worksheet 12b (pp. 26 and 27)

Assessment: Refer to the tracker for today's formal/informal oral, practical or written assessment activity.

Remediation: Give the learners Unifix cubes. Ask them to build the tallest tower they can. Ask: **Whose tower is the tallest? Whose tower is the shortest?**

Enrichment: See enrichment activity cards – learners can use any cards from the back of this book.

1. Mental mathematics

1.1 Counting (5 minutes)

Introduce learners to numbers by using number rhymes, songs and games. For example:

*One little bee blew and flew. He met a friend, and that made two;
Two little bees, busy as could be, along came another and that made three;
Three little bees, wanted one more. Found one soon and that made four;
Four little bees, going to the hive. Spied their little brother, and that made five;
Five little bees, working every hour. Buzz away, bees, and find another flower.*

1.2 Recall and strategies (10 minutes)

Make number symbol cards from old cereal boxes. Learners arrange the cards in the correct order.

2. Correction/reflection on homework (15 minutes)

Reflection/remediation based on previous day's work/homework.

3. Lesson content – concept development (30 minutes)

In this lesson you introduce some vocabulary that is used in the topic of length. It is important that you use all of the different words and demonstrate and explain their meaning to your class. You should also allow them the opportunity to say the words themselves.

Activity 1: Learners work in pairs

- Ask learners to stand back to back. They should compare their heights using words such as *taller* and *shorter*.
- Ask three learners to stand next to each other. Ask: **What can you tell me about A?** (Answer will vary depending on the heights of the learners: A is shorter than B but taller than C.)
- Do a few examples like this, using different learners.

Activity 2: Learners work in pairs

- Give the learners a variety of pencils or sticks.
- Tell the learners to take out (for example) two pencils. (You might work with different objects that demonstrate differences in thickness.)
- Ask: **What can you tell me about your pencils?** (This pencil is *thicker*/This pencil is *thinner*.)
- Do a few examples like this, using different pencils/sticks.

Activity 3: Learners work in pairs

- Give the learners some Unifix cubes.
- Ask them to make a tower with three blocks and another tower next to it with four blocks. (In this activity you are using the towers of Unifix cubes to demonstrate towers which are different in height.)
- Ask: **What can you tell me about your towers?** (The tower with **4** blocks is *higher*/The tower with **3** blocks is *lower*.)
- Do a few examples like this, using different numbers of blocks.

Activity 4: Whole class activity

- Give the learners some books.
- Each learner must take two books of different widths. (In this activity you are using the books to demonstrate differences in width.)
- Ask: **What can you tell me about your books?** (This book is *wider*/This book is *narrower*.)
- Do a few examples like this, using different books.

4. Classwork activity (25 minutes) (See next page)

5. Homework activity (5 minutes) (See next page)

6. Reflection on lesson

Term 1 Lesson 27: Length

Classwork

(Learners will draw pictures to match the instructions.)

1. Draw a short object and a longer object next to it.
2. Write the correct label under the pictures, i.e. 'short', 'long'.
3. Draw a short building and a taller building next to it.
4. Write the correct label under the pictures, i.e. 'short', 'tall'.
5. Draw a wide river and a narrower river next to it.
6. Write the correct label under the pictures, i.e. 'wide', 'narrow'.

Homework

(Learners will find various pictures.)

1. Cut out pictures from a magazine or newspaper to show something that is:
 - a) long
 - b) short
 - c) wide
 - d) narrow

LESSON 28: LENGTH

Teacher's notes

CAPS topics: 1.1 Count objects, 1.2 Count forwards and backwards, 1.16 Mental mathematics, 4.2 Length

Lesson vocabulary: Length, estimate, measure, long/longer than, short/shorter than, taller than, wider than, narrower than, thicker than, thinner than, order, record, non-standard units, size

Prior knowledge:

Learners should have been taught how to:

- Compare and order the length, height or width of two or more objects by placing them next to each other.
- Use language to talk about the comparison.

Concepts:

- Compare and order the length of two or more objects by placing them next to each other
- Estimate, measure, compare, order and record length using non-standard measures. Learners should measure a variety of objects using a range of objects as non-standard units

Resources: Matchboxes, Unifix cubes, objects to be measured (e.g. books, suitcases, desks, mats, etc.)

DBE workbook activities relevant to this lesson:

- DBE worksheet 12a (pp. 24 and 25)

Assessment: Refer to the tracker for today's formal/informal oral, practical or written assessment activity.

Remediation: Give the learners Unifix cubes and a book to measure. Help them to place Unifix cubes next to each other along the length of the book with no spaces in between. Ask them to touch and count the number of Unifix cubes. The learners should then say: The book is ____ Unifix cubes long. Help the learners to measure the width of their desks using bottle tops. The learners should then say, The desk is ____ bottle tops wide.

Enrichment: See enrichment activity cards – learners can use any cards from the back of this book.

1. Mental mathematics

1.1 Counting (5 minutes)

Count forwards and backwards in ones from 1 to 65, starting from any given number, e.g. 60, 61/50, 49.

1.2 Recall and strategies (10 minutes)

(Learners write their answers on their slates and hold it up for you to see.)

	Which is less?	Answer
1.	1 or 9?	1
2.	2 or 10?	2
3.	5 or 6?	5
4.	9 or 0?	0
5.	12 or 7?	7

	Which is less?	Answer
6.	11 or 7?	7
7.	6 or 10?	6
8.	7 or 0?	0
9.	8 or 12?	8
10.	10 or 0?	0

2. Correction/reflection on homework (15 minutes)

Reflection/remediation based on previous day's work/homework.

3. Lesson content – concept development (30 minutes)

In this lesson you introduce measurement of length. Non-standard units of measurement are used to help learners understand how length is measured by comparing the length of one object to the length of another object. You should demonstrate how non-standard units are used to measure length and also give the learners the opportunity to do it themselves.

Activity 1: Learners work in groups

- Give each learner some Unifix cubes, matchboxes and bottle tops (the bottle tops must be of equal size).
- Encourage the learners to sort these objects.
- Explain that when you measure the length of an object, you must choose one kind of object to measure with, e.g. you can choose to measure with blocks or bottle tops but not blocks and bottle tops together.
- Explain that there are two ways to use non-standard units:
 - using a number of objects of the same length laid out in a row across/along the object being measured;
 - using only one object as the non-standard unit and moving it along as you measure.

Activity 2: Whole class activity

- Ask the learners to choose an object from their sorted piles with which they would like to measure.
- Ask them to measure the length of their Mathematics books with the chosen objects.
- Ask learners to compare their measurements with the learners sitting near them.
- Ask: **Do you have the same measurements?** (No). **Why not?** (Because our objects are different sizes.)
- The discussion about differences found in measurement when different non-standard units are used is important. It might motivate your learners to ask why they don't all use the same unit to measure with. This is very important as this insight leads into the discussion of standard units which will ultimately be used to do more accurate measurements.
- Even though learners may have found different measurements – they should still be able to agree on the following:
 - Ask: Which edge is **longer?** (The length).
 - Ask: Which edge is **shorter?** (The width).

Activity 3: Groups of four – optional

- Repeat the above (if there is time), but the learners choose a different non-standard unit of measurement and discuss their findings.

4. Classwork activity (25 minutes) (See next page)

5. Homework activity (5 minutes) (See next page)

6. Reflection on lesson

Term 1 Lesson 28: Length

Classwork

1. What is the length of this book?

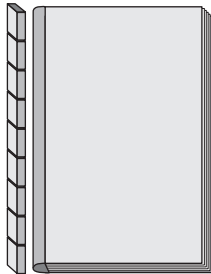

The book is ___ (9) matchboxes long.

2. What is the width of this book?



The book is ___ (4) matchboxes wide.

3. How many counters long is each side?

a) (5)

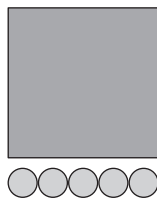

b) (10)

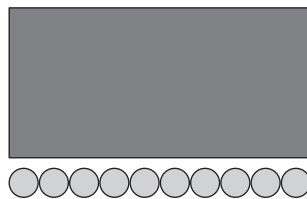

c) (4)

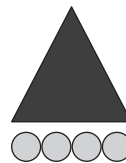

4. Measure the width of your table using your Unifix cubes.

My table is ___ Unifix cubes wide. (Various answers)

5. Measure the length of your pencil using your Unifix cubes.

My pencil is ___ Unifix cubes long. (Various answers)

6. Measure the width of your chair using your Unifix cubes.

My chair is ___ Unifix cubes wide. (Various answers)

Homework

1. Measure the width of your bed using a pencil.

My bed is ___ pencils wide. (Various answers)

2. Measure the length of your bed using a pencil.

My bed is ___ pencils long. (Various answers)

WEEK 9

LESSON 29: GEOMETRIC PATTERNS

Teacher's notes

CAPS topics: 1.16 Mental mathematics, 2.1 Geometric patterns

Lesson vocabulary: Geometric pattern, pattern, copy, extend, repeat, more, less

Prior knowledge:

Learners should have been taught how to:

- Copy and extend simple patterns using physical objects and drawings.

Concepts:

- Copy and extend simple patterns using physical objects and drawings

Resources: Balls, boxes, books, cans, crayons, tins, coloured counters, Unifix cubes, geometric pattern cards (create a variety of these according to the example given below)

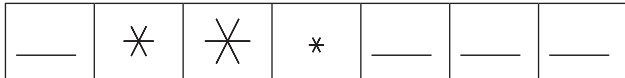
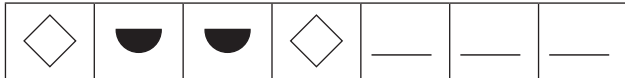

DBE workbook activities relevant to this lesson:

- N/A

Assessment: Refer to the tracker for today's formal/informal oral, practical or written assessment activity.

Remediation: Find real objects that are similar to the ones on the geometric pattern cards. Show the first step of the pattern. Ask the learners to copy the pattern with their objects. Then show them how to extend the pattern by repeating it again.

Enrichment: See enrichment activity cards – learners can use any cards from the back of this book.

1. Mental mathematics

1.1 Counting (5 minutes)

Learners order a set of familiar numbers and place them on a number line.

1.2 Recall and strategies (10 minutes)

Ask: **Which is more: 2 or 3? (3), 4 or 5? (5), 1 or 4? (4), 3 or 5? (5)/Which is less? 4 or 5? (4), 3 or 2? (2), 4 or 2? (2), 1 or 4? (1)**

2. Correction/reflection on homework (15 minutes)

Reflection/remediation based on previous day's work/homework.

3. Lesson content – concept development (30 minutes)

Activity 1: Learners work in groups

- Arrange a number of objects (e.g. can, box, box, can, box, box, can) in a pattern on a table/your desk at the front of the classroom.
- Ask the learners to copy and draw the pattern in their workbooks.
- Do a second example (e.g. ball, can, book, ball, can, book).
- Ask a few learners to suggest some other patterns and show them to the class.

Activity 2: Whole class activity

- Set up another pattern on your desk (e.g. ball, box, ball, box).
- Clap out the pattern for the learners (i.e. 1 clap (ball), 2 claps (box), 1 clap (ball), 2 claps (box)).
- Ask the learners to clap out the pattern with you (1 clap, 2 claps, 1 clap, 2 claps).
- Repeat with other patterns – ask a few learners to suggest ideas that they show the class and the whole class claps the new patterns together.

Activity 3: Whole class activity

- Give the learners geometric pattern cards that you have prepared for this lesson, and ask them to copy the pattern.
- If you were unable to prepare pattern cards, draw a few different patterns on the board for the class to refer to.
- **Note:** In some patterns:
 - the size of the objects varies, but the groups are repeated in exactly the same way.
 - the same object is repeated, but the colour changes.
 - different objects make up a group, and then the group of objects is repeated.
 - repeating groups can be made up of the same objects that are positioned in different ways.

4. Classwork activity (25 minutes) (See next page)

5. Homework activity (5 minutes) (See next page)

6. Reflection on lesson

Term 1 Lesson 29: Geometric patterns

Classwork

1. Extend the patterns.

a) 

b) 

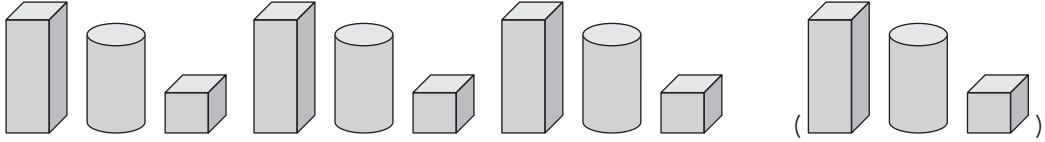
c) 

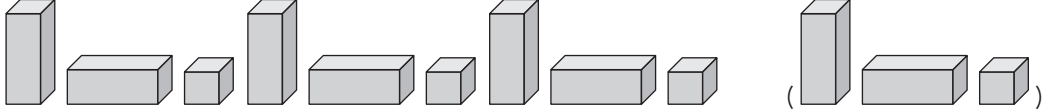
d) 

2. Fill in the missing spaces to complete the pattern.

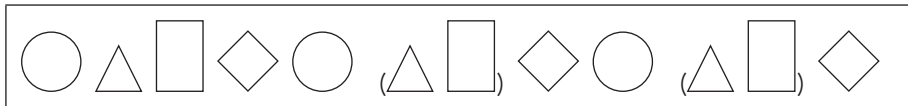

3. Draw your own pattern. (Learners will draw various patterns.)

Homework

1. Extend the pattern.

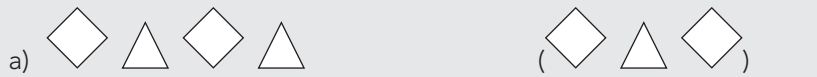
a) 

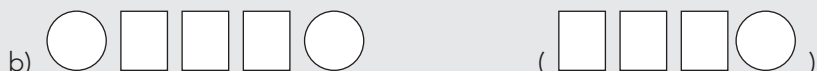
b) 

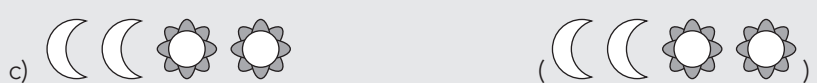
c) 

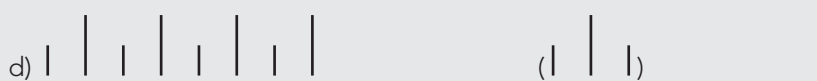
d) 

LESSON 30: DATA – SORT OBJECTS

Teacher's notes

CAPS topics: 1.1 Count objects, 1.16 Mental mathematics, 5.1 Collect and sort objects, 5.2 Represent sorted collection of objects, 5.3 Discuss and report on sorted collection of objects

Lesson vocabulary: Collect, sort objects, estimate, sort, compare, collection, more than, less than and the same as

Prior knowledge:

Learners should have been taught how to:

- Collect and sort everyday objects.
- Draw a picture of the collected objects.
- Answer questions about how the collection was sorted and about the drawing of the collection.

Concepts:

- Collect and sort everyday objects
- Draw a picture of the collected objects
- Describe the collection and give reasons for how the objects were sorted

Resources: 0–5 number symbol cards, shapes, bottle tops, counters of various sizes and colours, Unifix cubes

DBE workbook activities relevant to this lesson:

- DBE worksheet 28 (p. 60)

Assessment: Refer to the tracker for today's formal/informal oral, practical or written assessment activity.

Remediation: Give the learners Unifix cubes, and ask them to sort them any way they want to. Ask learners to explain why they sorted their blocks the way that they did. Encourage learners to recognise that some may have been sorted according to colour. Repeat with different colour combinations.

Enrichment: See enrichment activity cards – learners can use any cards from the back of this book.

1. Mental mathematics

1.1 Counting (5 minutes)

Introduce learners to numbers by using number rhymes, songs and games. (Use previous examples.)

1.2 Recall and strategies (10 minutes)

Give each learner 0–5 number cards. Ask them to choose one card. Then ask them to give you a number that is two more than the one they have chosen, then give you a number that is two less. Then ask: **What can you tell me about this number?** Learners must use the language of *more than*, *less than* and *the same as*, and also describe numbers as (e.g.) 4 is 2 more than 2.

2. Correction/reflection on homework (15 minutes)

Reflection/remediation based on previous day's work/homework.

3. Lesson content – concept development (30 minutes)

Activity 1: Learners work in groups

- Give them bottle tops to sort according to their own criteria.
- Ask: **How did you sort the bottle tops?**
- **Who did it the same way?**
- **Who did it a different way?**
- Discuss the different ways that people did sorting – this shows that they were using a different idea to guide their sorting. As long as the idea guiding the sorting is followed consistently the sorting will be correct.
- Ask learners to sort their bottle tops again but in a different way this time.
- Ask the learners to make a drawing of their different sets of sorting.

Activity 2: Whole class activity

- Give learners counters.
- Ask: **What do you notice about the counters?** (They are *different* colours.)
- Ask learners to sort the counters according to colour.
- Ask learners to make a drawing of their sorting.

Activity 3: Whole class activity

- Give learners different shapes.
- Ask: **What do you notice about the shapes?** (There are triangles, squares and circles.)
- Tell learners to sort the items according to shape.
- Ask the learners to make a drawing of their sorting.

4. Classwork activity (25 minutes) (See next page)

5. Homework activity (5 minutes) (See next page)

6. Reflection on lesson





Lesson 30: Data – sort objects

Classwork

1. Sort the shapes. Make a drawing of your sorted shapes.

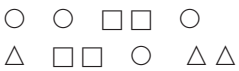
a)  ( )

b)  ( )

c)  (  )

2. Draw your own collection of shapes.

(Various drawings)

3. Sort your shapes by making a drawing.

(Various drawings)

4. How many shapes of each type did you draw?

(Various answers)

Homework

1. Draw the shapes below into your homework book.

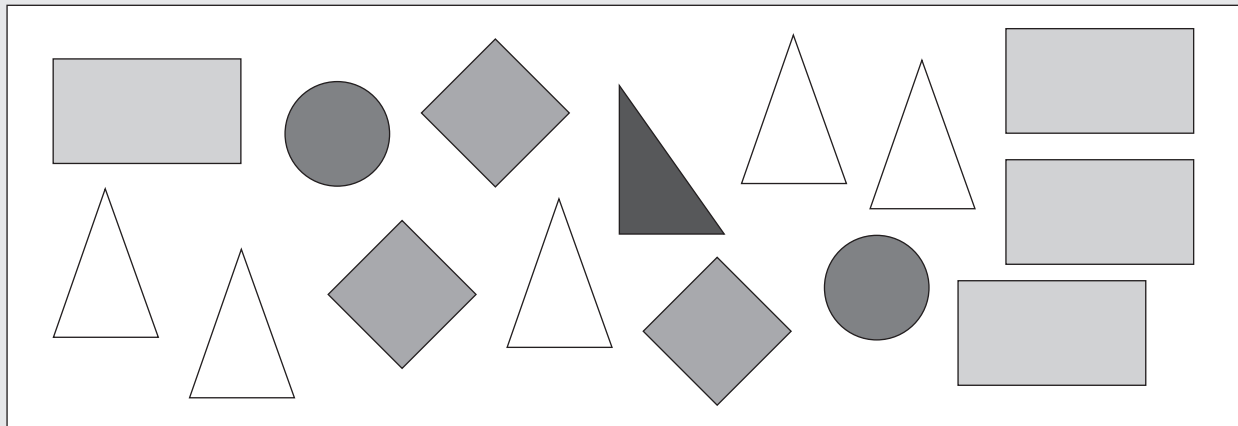

2. Sort the shapes by making another drawing.

(Various drawings)

3. Write how many of each shape you had.



LESSON 31: DATA – SORT OBJECTS

Teacher's notes

CAPS topics: 1.1 Count objects, 1.16 Mental mathematics, 5.1 Collect and sort objects, 5.2 Represent sorted collection of objects, 5.3 Discuss and report on sorted collection of objects

Lesson vocabulary: Collect, collection, sort, describe

Prior knowledge:

Learners should have been taught how to:

- Collect and sort everyday objects.
- Draw a picture of the collected objects.
- Answer questions about how the collection was sorted and about the drawing of the collection

Concepts:

- Collect and sort everyday objects
- Draw a picture of the collected objects
- Describe the collection, and give reasons for how the objects were sorted

Resources: Glass jars, Unifix cubes, bottle tops, various coloured beads

DBE workbook activities relevant to this lesson:

- DBE worksheet 28 (p. 61)

Assessment: Refer to the tracker for today's formal/informal oral, practical or written assessment activity.

Remediation: Give the learners beads to sort (e.g. **6** red, **4** green, **1** yellow). Ask learners to explain why they sorted their beads the way that they did. Encourage learners to recognise that some sortings may have been done according to colour. Repeat with different colour combinations.

Enrichment: See enrichment activity cards – learners can use any cards from the back of this book.

1. Mental mathematics

1.1 Counting (5 minutes)

Learners use a number line to count forwards and backwards in ones to a maximum of 20. Ask learners to start at different numbers and count on from there.

1.2 Recall and strategies (10 minutes)

Learners estimate numbers in real life contexts. Show learners 10 Unifix cubes in a clear jar. Show them a second jar with 5 Unifix cubes. Ask: **If there are 10 Unifix cubes in the first jar, how many do you think are in this jar?** Repeat with other numbers.

2. Correction/reflection on homework (15 minutes)

Reflection/remediation based on previous day's work/homework.

3. Lesson content – concept development (30 minutes)

Activity 1: Whole class activity

- Give each group of learners some objects to sort, e.g. Unifix cubes, beads, bottle tops, etc.
- Ask the learners to sort the objects.
- Have a whole class discussion about the sorted objects. (Call on as many different groups as possible to respond in the discussion.)
- Ask: **How did you sort the objects?**
- **Who sorted theirs the same way?**
- **Which group of sorted objects has the most items?**
- **Which group of sorted objects has the least items?**
- **How many objects did you have at the beginning? Do you still have the same number of objects?**
- Ask the learners to draw their sorted groups of objects.

Activity 2: Learners work individually

- Give each learner his/her own set of objects to sort, e.g. Unifix cubes and crayons.
- Repeat the above activity, but have learners working individually.
- Learners must sort their objects according to a chosen rule.
- They should display their objects on their desks.
- They should draw their sorted objects.

4. Classwork activity (25 minutes) (See next page)

5. Homework activity (5 minutes) (See next page)

6. Reflection on lesson

Term 1 Lesson 31: Data – sort objects

Classwork

1. Sort the shapes. Make a drawing of your sorted shapes.

a)		(●●●● ○○○○)
b)		(●●●●●● ○○○○○○)
c)		(●●●●●● ○○○○○○)

2. a) Draw the following in groups according to the type of shape:

3 triangles

5 squares

1 circle

4 rectangles

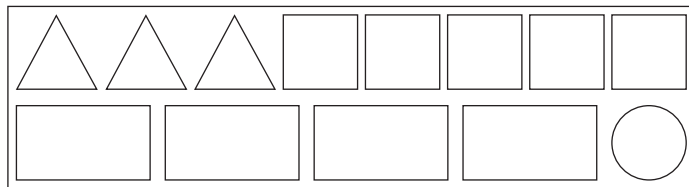

b) How many types of shapes did you draw? (4)

c) How many shapes did you draw altogether? (13)

Homework

1. Look around your home to find:

3 red objects

2 blue objects

4 black objects

1 green object.

2. Draw a picture of your objects in their colour groups.

(Various drawings)

LESSON 32: MASS

Teacher's notes

CAPS topics: 1.2 Count forwards and backwards, 1.16 Mental mathematics, 4.3 Mass

Lesson vocabulary: Mass, heavy, light, heavier, lighter, heaviest, lightest, balance, measure, compare, record, balance scale.

Prior knowledge:

Learners should have been taught how to:

- Estimate, measure, compare, order and record mass using a balancing scale and non-standard measures.
- Use words such as heavy, light, heavier and lighter when comparing objects.

Concepts:

- Estimate, measure, compare, order and record mass using a balancing scale and non-standard measures, e.g. blocks, bricks, etc.
- Use language to talk about the comparison, e.g. *light, heavy, lighter, heavier*

Resources: Balance scale (make your own one using a coat hanger, string and two plastic yoghurt tubs if necessary), objects found in the classroom to use to compare mass

DBE workbook activities relevant to this lesson:

- N/A

Assessment: Refer to the tracker for today's formal/informal oral, practical or written assessment activity.

Remediation: Give one learner two objects to hold, one in each hand. Ask: **Which object is heavier? Which object is lighter?** Place it on the scale to check. **Were you correct?** Do this a few times with different objects.

Enrichment: See enrichment activity cards – learners can use any cards from the back of this book.

1. Mental mathematics

1.1 Counting (5 minutes)

Count forwards and backwards in fives from any multiple between 0 and 80, e.g. 55, 60, 65

1.2 Recall and strategies (10 minutes)

	What is 2 less than:	Answer
1.	10	8
2.	14	12
3.	9	7
4.	13	11
5.	15	13

	What is 2 more than:	Answer
6.	9	11
7.	11	13
8.	13	15
9.	8	10
10.	10	12

2. Correction/reflection on homework (15 minutes)

Reflection/remediation based on previous day's work/homework.

3. Lesson content – concept development (30 minutes)

In this lesson you consolidate the vocabulary that is used in the topic of mass which was introduced in the previous lesson. It is important that you use all of the different words and demonstrate and explain their meaning to your class. You should also allow them the opportunity to say the words themselves. You could aim to allow each learner to have used at least two of the new vocabulary words by the end of this lesson.

Activity 1: Learners work in groups

- Ask the learners to lift a suitcase and a book (one in each hand).
- Ask: **What can you tell me about the suitcase and the book?** (The suitcase is *heavier* than the book/the book is *lighter* than the suitcase.)
- Ask the learners to replace the suitcase with a pencil.
- Ask: **What can you tell me about the book and the pencil?** (The book is *heavier* than the pencil/the pencil is *lighter* than the book.)
- Ask: **What can you tell me about the suitcase, the book and the pencil?** (The suitcase is *light*, the book is *lighter* and the pencil is the *lightest*/the suitcase is the *heaviest*, etc.)

Activity 2: Learners work in groups

- Place a balance scale on your table, or allow a learner to hold your homemade scale using the handle of the hanger.
- Place an object in each tub.
- Ask: **Do the objects have the same mass, or is one heavier?**
- Ask the learners to find two objects that have the same mass by trying out a few objects in the scale.
Which two objects have the same mass?
- Ask the learners to find two objects that have different masses by trying out a few objects in the scale.
Ask: **Which object has a smaller/greater mass?**

4. Classwork activity (25 minutes) (See next page)

5. Homework activity (5 minutes) (See next page)

6. Reflection on lesson

Term 1 Lesson 32: Mass

Classwork

1. Which side is heavier? (b)

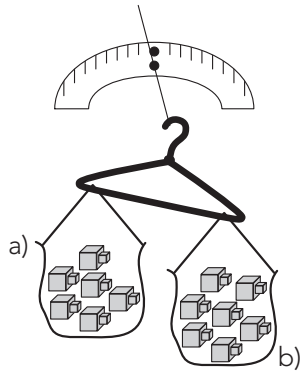

2. Which side is lighter? (b)

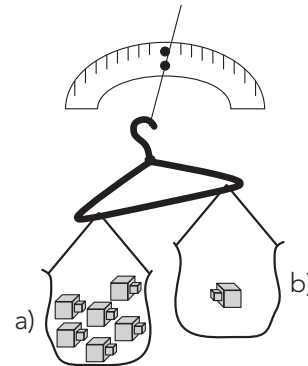

3. Which side is lighter? (a)

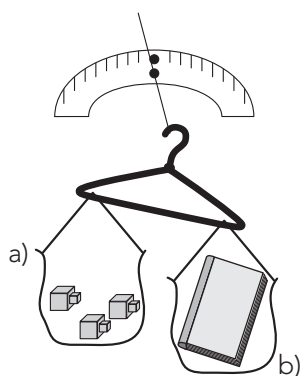

4. Which side is heavier? (a)

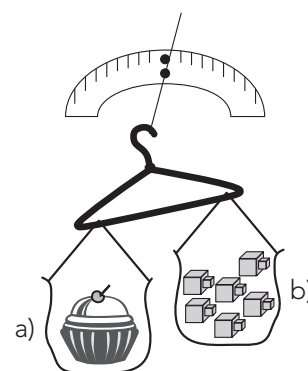

5. Draw counters in bags on a scale to show:

a) Heavier and lighter

b) The same mass

(Learners will draw counters in bags.)

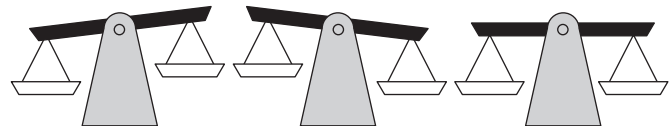

Homework

1. Find two objects at home that you think have the same mass.
2. Draw the objects in your homework book.
3. Find an object that you think is heavier than the two objects you found.
4. Find an object that you think is lighter than the two objects that you found.
(Learners will follow the instructions and provide various drawings.)

WEEK 10

LESSON 33: MASS – HEAVY AND LIGHT

Teacher's notes

CAPS topics: 1.16 Mental mathematics, 4.3 Mass

Lesson vocabulary: Heavy, heavier, light, lighter, estimate, measure, compare, order, record, compare, balance scales

Prior knowledge:

Learners should have been taught how to:

- Compare and order the mass of two or more objects by feeling them or using a balancing scale.
- Use relevant language to talk about comparison.

Concepts:

- Estimate, measure, compare, order and record mass using a balancing scale and non-standard measures
- Use relevant language to talk about comparison

Resources: A variety of heavy and light objects (e.g. kitchen items), one or more balance scales, heavy and light flashcards

(If you do not have a commercial balance scale, you could make one by hanging two identical containers on either end of a coat hanger. You could use yoghurt containers or the cut-off bases of 2-litre plastic milk or cool drink bottles.)

DBE workbook activities relevant to this lesson:

- N/A

Assessment: Refer to the tracker for today's formal/informal oral, practical or written assessment activity.

Remediation: Give the learners a balance scale and a variety of items from the kitchen. Ask them to place an item on the one side of the balance scale and stones on the other side to balance the scale. They must count how many stones they need to balance each item. Choose the stones in such a way that you don't need more than ten.

Enrichment: See enrichment activity cards – learners can use any cards from the back of this book.

1. Mental mathematics

1.1 Counting (5 minutes)

Learners use a number line to count forwards and backwards in ones to a maximum of 20. Ask learners to start at different numbers and count on from there.

1.2 Recall and strategies (10 minutes)

Give learners a variety of everyday word problems e.g. **If we have 7 cards and we take one away, how many are left? (6)** Learners use counters to solve the problems.

2. Correction/reflection on homework (15 minutes)

Reflection/remediation based on previous day's work/homework.

3. Lesson content – concept development (30 minutes)

In this lesson you introduce some vocabulary that is used in the topic of mass. It is important that you use all of the different words and demonstrate and explain their meaning to your class. You should also allow them the opportunity to say the words themselves.

Activity 1: Learners work in groups

- You need to use the resources that you prepared for this lesson. It is important that learners are given the chance to hold the different objects while they compare their masses. This is a practical activity!
- Give each group some heavy and light objects.
- Ask learners to pick up two of the objects.
- Ask learners: **What can you tell me about your two objects?** (This one is *heavy*/This one is *light*.)
- Hold up the flashcard *heavy* or *light* whenever learners use the word.
- Ask learners to find two different objects that are *heavier* than one of their two objects.
- Ask learners to find two different objects that are *lighter* than one of their two objects.

Activity 2: Learners work in groups

- Learners work with the balance scale which you prepared for this lesson.
- Ask learners to place identical objects on either side of the balance scale. (This will demonstrate that the bar/base of the coat hanger/balance scale is horizontal when the two objects have the same mass.)
- Ask learners to compare objects by placing one object in each side of the balance scale to see which is *heavier* or *lighter*.

4. Classwork activity (25 minutes) (See next page)

5. Homework activity (5 minutes) (See next page)

6. Reflection on lesson

Term 1 Lesson 33: Mass – heavy and light

Classwork

1. Draw blocks on each side of the scale to make it true.

a) (Learners draw more blocks on the left)

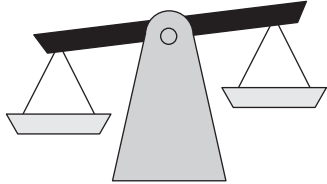

b) (Learners draw the same number of blocks on both sides)

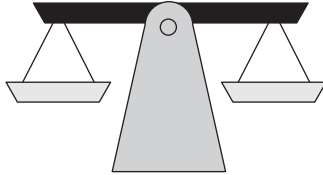

c) (Learners draw more blocks on the right)

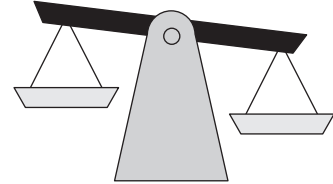

2. Draw a scale to show that an apple is heavier than a pear.

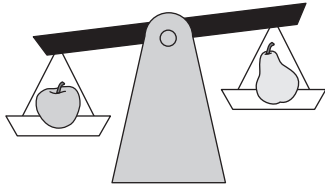

3. Draw a scale to show that a peanut is lighter than an orange.

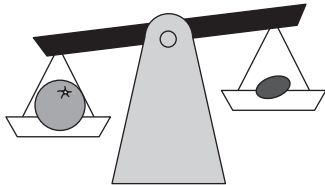

4. Look at the scales and compare the fruit.

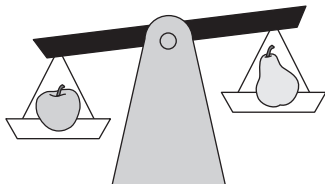

a) The (pear) is the lightest.

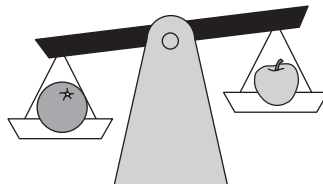

b) The (orange) is the heaviest.

Homework

1. Find two objects at home, and hold one in each hand to compare their mass.
2. Decide which object is heavier and which object is lighter.
3. Draw each object in your homework book.
4. Write the word 'heavy' below the heavier object and 'light' below the lighter object.
(Learners will follow the instructions and provide various drawings)

LESSON 34: CAPACITY

Teacher's notes

CAPS topics: 1.1 Count objects, 1.2 Count forwards and backwards, 4.4 Capacity/volume

Lesson vocabulary: Full, empty, more than, less than, the same as, liquid, pouring, containers, compare, order, amount, record

Prior knowledge:

Learners should have been taught how to:

- Compare and order the amount of liquid in two containers placed next to each other and check by pouring into a third container.
- Use language to talk about comparison.

Concepts:

- Compare and order the amount of liquid in two containers placed next to each other, and check by pouring into a third container

Resources: Strings of **five** and **ten** beads, variety of containers, sand or water, cups, *full* and *empty* flashcards

DBE workbook activities relevant to this lesson:

- N/A

Assessment: Refer to the tracker for today's formal/informal oral, practical or written assessment activity.

Remediation: Give the learners a variety of empty containers. Ask learners how the containers could be filled. (**I can fill the container with water or milk or juice. I can fill the bowl with sugar. I can fill the cup with tea, water and milk.**)

Enrichment: See enrichment activity cards – learners can use any cards from the back of this book.

1. Mental mathematics

1.1 Counting (5 minutes)

Learners use a number line to count forwards and backwards in ones to a maximum of 20. Ask learners to start at different numbers and count on from there.

1.2 Recall and strategies (10 minutes)

Learners estimate numbers in real life contexts. Show learners **10** beads on a string. Show them a second string with **5** beads. Ask: **If there were 10 beads on the first string, how many do you think are on this string?** Repeat with other numbers.

2. Correction/reflection on homework (15 minutes)

Reflection/remediation based on previous day's work/homework.

3. Lesson content – concept development (30 minutes)

In this lesson you introduce some vocabulary that is used in the topic of capacity. It is important that you use all of the different words and demonstrate and explain their meaning to your class. You should also allow them the opportunity to say the words themselves.

Activity 1: Learners work in groups

- Show the learners a variety of containers holding differing amounts of water.
- Ask: **What can you tell me about the containers?** (That container has *more* water than this container/That container has less water than that one/This container has *no* water.)
- Ask: **What word can we use to describe a container that has nothing in it?** (*Empty*).
- Ask: **What word can we use to describe a container that has no more space for any more water?** (*Full*)
- Ask learners to use the words *full* and *empty* in sentences (e.g. My juice bottle is *full*/The dustbin is *empty*)

Activity 2: Learners work in groups

- Place two similar empty containers on each group's table.
- In this activity it is suggested that learners fill containers using water. If this is not possible for you to do this in your class, you should use containers that are clearly different in size and ask learners to imagine filling them with water. But it would be better if you could use water to fill some containers in a demonstration if possible.
- Ask learners to fill one container with water using a cup.
- Ask learners to record on their scrap paper/whiteboards how many cups it took to fill the container.
- Repeat with the second container.
- Ask: **What did you notice about how many cups of water it took to fill the two containers?** (Answer: This container looks smaller, but it took the same number of cups of water as that container).
- Repeat with different containers.

4. Classwork activity (25 minutes) (See next page)



5. Homework activity (5 minutes) (See next page)

6. Reflection on lesson

Term 1 Lesson 34: Capacity

Classwork

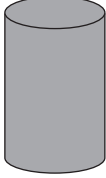
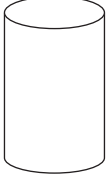
1. Write the correct word.

a) (full)/empty 	b) full/(empty) 	a)  Full	b)  Empty
--	--	--	--

2. Draw containers to show the following:

3. Draw containers to show the following: (Learners' answers will vary.)

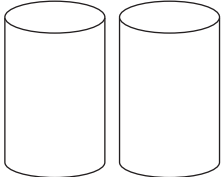
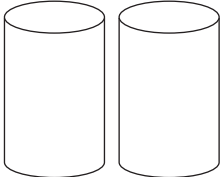
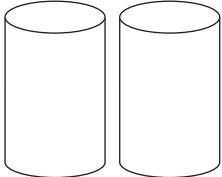
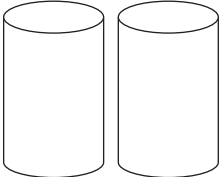
a)  More than	b)  Less than	c)  Equal	d)  Equal
--	--	---	--

4. Draw two containers of your own, and label them. (Various drawings)

Homework

1. Write the word/s:

- a) empty
- b) full
- c) more than
- d) less than.

(Learners write the words in their homework books)

2. Draw a picture to show each of the words you wrote.

(Various pictures)

LESSON 35: POSITION

Teacher's notes

CAPS topics: 1.1 Count objects, 1.16 Mental mathematics, 3.1 Position, orientation and views, 4.2 Length

Lesson vocabulary: On top of, in front of, behind, left, right, up, down, next to

Prior knowledge:

Learners should have been taught how to:

- Describe the position of one object in relation to another.
- Follow directions to move around the classroom.
- Compare and order the length, height or width of two or more objects by placing them next to each other.
- Use language to talk about the comparison.

Concepts:

- Follow directions to move around the classroom
- Follow instructions to place one object in relation to another
- Describe the position of one object in relation to another

Resources: Unifix cubes, position vocabulary cards (on top of/under/in front of/behind/to the left of/to the right of/next to)

DBE workbook activities relevant to this lesson:

- DBE worksheet 24b (pp. 52 and 53)

Assessment: Refer to the tracker for today's formal/informal oral, practical or written assessment activity.

Remediation: Ask the learners to build trains with Unifix cubes (using **1** block, **2** blocks, **3** blocks, **4** blocks and **5** blocks). Tell the learner to take any two trains and tell you which one is shorter and which one is longer. Ask them to put a counter **on top of/under/in front of/behind/to the left of/to the right of/next to** one of their trains.

Enrichment: See enrichment activity cards – learners can use any cards from the back of this book.

1. Mental mathematics

1.1 Counting (5 minutes)

Introduce learners to numbers by using number rhymes, songs and games. For example:

Five fat sausages frying in a pan – all of a sudden one went BANG!

Four ...; Three ... , Two... One fat sausage frying in a pan – all of a sudden it went BANG!

No fat sausages frying in a pan!

1.2 Recall and strategies (10 minutes)

Ask the learners to use their fingers to show you *more than/less than/the same number* as the fingers you hold up.

2. Correction/reflection on homework (15 minutes)

Reflection/remediation based on previous day's work/homework.

3. Lesson content – concept development (30 minutes)

In this lesson you introduce some vocabulary that is used in the topic of position. It is important that you use all of the different words and demonstrate and explain their meaning to your class. You should also allow them the opportunity to say the words themselves.

Activity 1: Learners work in groups

- Tell the learners to stand *on top of/under/in front of/behind/to the left of/to the right of/next to* their chairs and their tables.
- Ask them to tell you where they are standing using the appropriate vocabulary.
- You should use all of the vocabulary in this activity – in connection with learners and where they are standing in relation to their desks/chairs.

Activity 2: Learners work in groups

- Give the learners some Unifix cubes.
- Point to the position card *on top of* and tell the learners to place a Unifix cube on top of another object.
- Get learners to use the correct vocabulary, e.g. to say, **The Unifix cube is on top of the chair/the chair is under the Unifix cube.**
- Do the same with all the other position words. Once again, you should use all of the vocabulary in this activity – this time in connection with the position of the Unifix cubes and other objects.

Activity 3: Whole class activity

- Ask the learners to show you any two objects in the class that are near to each other.
- Ask them whether the object is *on top of/under/in front of/behind/next to/to the left of/to the right of* another object.
- You should use all of the vocabulary in this activity – this time in connection with the position of the objects identified by the learners in relation to each other.

4. Classwork activity (25 minutes) (See next page)

5. Homework activity (5 minutes) (See next page)

6. Reflection on lesson

Term 1 Lesson 35: Position

Classwork

1. Look at the row of shapes and answer the questions.

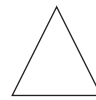
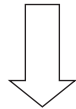

- Which shape is next to the arrow? (or)
- Which shape is between the star and the smiley face? ()
- Which shape is last in line? ()
- Which shape is first in line? ()

2. Draw a row of shapes.

- Draw a circle at the front of the row.
- Draw a square at the back of the row.
- Draw a triangle after the circle.
- Draw a diamond before the square.
- Draw a rectangle in between the triangle and the diamond.

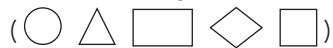

3. Draw a girl behind her desk.

(Learners will draw the picture to match the instructions.)

Homework

1. Draw a picture of a cat on top of a table.
(Learners will draw the picture to match the instructions.)

2. Complete the sentences below using these words.

in front of

in between

next to

after

before

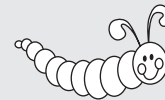

- The butterfly is _____ (in between) the bunny and the cat.
- The caterpillar is _____ (after) the ball.
- The bunny is _____ (in front of/before/next to) the butterfly.
- The flower is _____ (in front of/before/next to) the ball.
- The cat is _____ (in front of/before/next to) the flower.

LESSON 36: POSITION – FOLLOW DIRECTIONS

Teacher's notes

CAPS topics: 1.1 Count objects, 1.9 Grouping and sharing leading to division, 3.1 Position, orientation and views

Lesson vocabulary: Above, below, left, right, up, down, next to, on top of, behind, in front of, left-hand side, right-hand side

Prior knowledge:

Learners should have been taught how to:

- Describe the position of one object in relation to another object using language.

Concepts:

- Describe the position of one object in relation to another

Resources: Arrow cards (as shown below), balls, coloured boxes, classroom items



DBE workbook activities relevant to this lesson:

- DBE worksheet 24a (pp. 50 and 51)

Assessment: Refer to the tracker for today's formal/informal oral, practical or written assessment activity.

Remediation: Give the learners balls and boxes and ask them to: **Place the blue box behind the pink box. Place the yellow box on the right-hand side of the green box. Place the orange box on top of the purple box.** Etc.

Enrichment: See enrichment activity cards – learners can use any cards from the back of this book.

1. Mental mathematics

1.1 Counting (5 minutes)

Introduce learners to numbers by using number rhymes, songs and games. (Use previous examples.)

1.2 Recall and strategies (10 minutes)

Ask learners to show you a number that is smaller than 4. Learners write the number on their scrap paper/whiteboards and hold them up for you to see. Repeat with other numbers.

2. Correction/reflection on homework (15 minutes)

Reflection/remediation based on previous day's work/homework.









3. Lesson content – concept development (30 minutes)

Daily Activity: Whole class activity

Do these daily activities with the learners when you have a chance at the beginning or end of a lesson:

- **Put the crayons next to the counters.**
- **Put the number cards on top of the cupboard.**
- **Come to the front of the class.**
- **Stand next to your chair.**
- **Jump over the dustbin.**
- Other questions/instructions that consolidate the vocabulary of position.

Activity 1: Learners work in groups

- In this lesson you will need cards with the following arrows on them:    
- Show the learners the direction arrows and explain them.
-  going up  going down  going right  going left
- Show the learners a card.
- Ask the learners to make a body movement that will go with that card.
- Repeat with all the cards.

Note: This activity could also be incorporated into your daily activities.

Activity 2: Learners work in groups

- Give learners coloured boxes and balls and ask them to do the following:
- **Place the blue box behind the pink box.**
- **Place the yellow box on the right-hand side of the green box.**
- **Place the orange box on top of the purple box.**
- **Place the red ball on top of the white box.**

Activity 3: Whole class activity

- Get learners to use the vocabulary by asking questions like:
- **What can you tell me about the dustbin?** (The dustbin is on the left-hand side of my table.)
- **What can you tell me about the book?** (The book is on top of the cupboard.)
- **What can you tell me about the poster?** (The poster is at the back of the class.)
- **What can you tell me about the chalk?** (The chalk is on my desk.)
- **What can you tell me about where John is sitting?** (John sits between Simon and Busi.)
- Other questions/instructions that allow learners to practice the vocabulary of position.

4. Classwork activity (25 minutes) (See next page)

5. Homework activity (5 minutes) (See next page)



6. Reflection on lesson

Term 1 Lesson 36: Position – follow directions

Classwork

1. Complete the sentences below using these words.

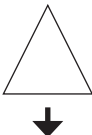
above *left* *below* *right*

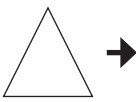
a)		The arrow is _ (above) the triangle.
b)		The arrow is _ (below) the triangle.
c)		The arrow is on the _ (left) of the triangle.
d)		The arrow is on the _ (right) of the triangle.

2. Draw a picture.

- Draw a black box in the middle of your page.
 - Draw a red ball above the box.
 - Draw a green box below the black box.
 - Draw a yellow ball next to the green box.
- (Learners will draw the picture to match the instructions.)









3. Draw a picture.

- Draw a tree in the middle of the page.
 - Draw a cloud above the tree.
 - Draw a sun on the left-hand side of the cloud.
- (Learners will draw the picture to match the instructions.)

Homework

Complete the sentences below using these words.

above *left* *below* *right*

-   The bicycle is on the _____ (right) of the flower.
-   The bicycle is on the _____ (left) of the flower.
-  _____ (above) the flower.

-  _____ (below) the flower.

WEEK 11

LESSON 37: GROUPING

Teacher's notes

CAPS topics: 1.16 Mental mathematics, 1.9 Grouping and sharing leading to division

Lesson vocabulary: Compare, more, less, group, remainder, grouping, sharing

Prior knowledge:

Learners should have been taught how to:

- Solve word problems by sharing equally.

Concepts:

- Practically solve problems involving equal sharing and grouping with whole numbers up to 5 and with answers that may include remainders

Resources: Hoops (or circles drawn in the sand), counters, crayons, cups)

DBE workbook activities relevant to this lesson:

- DBE worksheet 30 (pp. 64 and 64)

Assessment: Refer to the tracker for today's formal/informal oral, practical or written assessment activity.

Remediation:

- Give learners **four** counters. Ask them how many cups of **two** counters they can make. (**two**)
- Give learners **four** counters. Ask them how many cups of **one** counter they can make. (**four**)
- Give learners **five** counters. Ask them how many cups of **two** counters they can make. (**two** with one counter left over)
- Give learners **five** counters. Ask them how many cups of **one** counter they can make. (**five**)

Enrichment: See enrichment activity cards – learners can use any cards from the back of this book.

1. Mental mathematics

1.1 Counting (5 minutes)

Learners use a number line to count forwards and backwards in ones to a maximum of 20. Ask learners to start at different numbers and count on from there.

1.2 Recall and strategies (10 minutes)

Give learners a variety of everyday word problems, e.g. **If we see 5 birds and one flies away, how many are left?** (4) Learners use counters to solve the problems and then write their answers on their blackboards.

2. Correction/reflection on homework (15 minutes)

Reflection/remediation based on previous day's work/homework.

3. Lesson content – concept development (30 minutes)

This is the first lesson of the term on division. The focus of this lesson is grouping division. In this kind of division objects are divided into groups of given size and learners have to find out how many such groups can be made. The questions given should involve grouping where there is no remainder and also where there is a remainder so that learners realise that there could be a remainder when division takes place right from the start.

In grouping division the key idea is the group size and the questions are *How many groups of this size can I make?* and *Will there be a remainder?*

Activity 1: Whole class activity

- Give learners **four** crayons.
- Ask learners to put the crayons into groups of **2**. Each group of **2** should be put into a cup.
- Ask: **How many cups with two crayons have you made?** (2)
- Ask: **Is there a remainder?** (No)
- Ask learners to put the crayons into groups of **3**. Each group of **3** should be put into a cup.
- Ask: **How many cups with three crayons have you made?**
- Ask: **Is there a remainder?** (Yes – one crayon is left over.)
- Give learners **three** crayons.
- Ask: **How many cups with one crayon can you make?** (3)
- Ask: **Is there a remainder?** (No)
- Ask learners to put the crayons into groups of **2**. Each group of **2** should be put into a cup.
- Ask: **How many cups with two crayons have you made?** (1)
- Ask: **Is there a remainder?** (Yes – one crayon is left over.)
- Discuss the grouping activities with the class – do they see that you group the items into a given group size and then count how many groups you find and check whether or not there is a remainder.

Activity 2: Learners work in groups

- Take the learners outside.
- Divide them into groups of **five**, and give each group **four** hoops, or draw **four** large circles in the sand. (Not all the hoops/circles will be used each time.)
- Ask the learners to stand in groups of **2**. Each group of **2** must go in a hoop.
- Ask: **How many groups of 2 learners do you have?**
- Ask: **Why is one person not standing in a hoop?** (We can't split a group of **5 learners** equally into **2** hoops – there is **one** left over.)
- Ask: **So what must we do with the one that is left over?** (Let learners problem solve, and provide a variety of suggestions like, **He can sit out for this activity/He can count to check that we did it right**/etc. It is important to not ignore the remainder. It must be acknowledged, so that learners get used to saying **5** grouped into **2s** is **2** with one left over.)
- Repeat with groups of **1**. Ask learners how many hoops/circles of one child each can they make. (**Four** hoops of **one** child with **one** child left over.)
- Repeat with **3** hoops and groups of **1**.

4. Classwork activity (25 minutes) (See next page)

5. Homework activity (5 minutes) (See next page)

6. Reflection on lesson

Lesson 37: Grouping

Classwork

1. Look at the counters. How many bags can you make?
- a) Bags with two counters? ○ ○ ○ ○ (2 bags)
 - b) Bags with one counter? ○ ○ ○ ○ (4 bags)
 - c) Bags with three counters? ○ ○ ○ ○ ○ (1 bag)
 - d) Bags with four counters? ○ ○ ○ ○ (1 bag)

2. Draw the bags of counters.
- a) (

○ ○

○ ○

)
 - b) (

○

○

○

○

)
 - c) (

○ ○ ○

 ○ ○)
 - d) (

○ ○ ○ ○

)

3. Draw this table into your book:

	How many groups of:	Draw the groups	Write the number:
a)	1 can you make? ● ● ● ● ●	(●) (●) (●) (●) (●)	(5)
b)	2 can you make? ● ● ●	(● ●) ●	(1)
c)	2 can you make? ● ● ● ●	(● ●) (● ●)	(2)
d)	3 can you make? ● ● ●	(● ● ●)	(1)
e)	4 can you make? ● ● ● ● ●	(● ● ● ●) ●	(1)

Homework

	How many groups of:	Draw the groups:	Write the number:
a)	1 can you make? ● ● ●	(●) (●) (●)	(3)
b)	2 can you make? ● ● ● ● ●	(● ●) (● ●) ●	(2)
c)	3 can you make? ● ● ● ●	(● ● ●) ●	(1)

LESSON 38: SHARING

Teacher's notes

CAPS topics: 1.2 Count forwards and backwards, 1.16 Mental mathematics, 1.9 Grouping and sharing leading to division

Lesson vocabulary: Share, forwards, backwards, equal sharing, sharing, grouping, whole numbers, remainder

Prior knowledge:

Learners should have been taught how to:

- Solve problems (story sums) involving equal sharing with whole numbers up to 10 and with answers that may include remainders.

Concepts:

- Practically solve problems involving equal sharing and grouping with whole numbers up to 5 and with answers that may include remainders

Resources: Counters, crayons

DBE workbook activities relevant to this lesson:

- DBE worksheet 29 (pp. 62 and 63)

Assessment: Refer to the tracker for today's formal/informal oral, practical or written assessment activity.

Remediation:

- Give learners **2** cups and **4** counters. Ask them to share the counters between the cups (**two**).
- Give learners **2** cups and **8** counters. Ask them to share the counters between the cups (**four**).
- Repeat with other numbers.

Enrichment: See enrichment activity cards – learners can use any cards from the back of this book.

1. Mental mathematics

1.1 Counting (5 minutes)

Learners use a number board to count forwards and backwards in ones to a maximum of 20. Tell learners to start at different numbers and count on from there.

1.2 Recall and strategies (10 minutes)

Write numbers 1 up to 5 on the board. Ask: **Which is more: 2 or 3? What can you tell me about 4 and 5?**

Which is less: 3 or 2?, etc.

2. Correction/reflection on homework (15 minutes)

Reflection/remediation based on previous day's work/homework.

3. Lesson content – concept development (30 minutes)

This is the second lesson of the term on division. The focus of this lesson is sharing division. In this kind of division objects are divided among a given number of people/etc. and learners have to find out how many items being shared, each person will get. The questions given should involve sharing where there is no remainder and also where there is a remainder so that learners realise that there could be a remainder when division takes place right from the start.

In sharing division the key idea is the number of people (etc.) among whom the items must be shared and the questions are *How many items will each person get?* and *Will there be a remainder?*

Activity 1: Whole class activity

- Give each pair of learners **four** crayons.
- Ask them to share the crayons between them in their pairs.
- Ask: **How many crayons do you each have? (2)**
- Ask: **Why don't some of you have 3 and others only 1?** (That would not be fair/That would not be sharing/ Sharing means we all have to have the same amount.)
- Ask: **How did you share the crayons?**
- **What did you do?** (We went **1** for you, **1** for me... until we were finished sharing)
- Get learners to share **6** crayons and **2** crayons in their pairs.
- Discuss the sharing.

Activity 2: Learners work in pairs

- Learners remain in their pairs with their crayons.
- Give each pair of learners **5** crayons.
- Ask them to share the crayons between them in their pairs.
- Ask: **How many crayons do you each have? (2 and 3/2 and 2, and there is one left over.)**
- Ask: **Why are there different answers?**
- **Why is this one different to sharing 4 crayons?** (We can't share **5** equally – there is **one** left over.)
- Ask: **So what must we do with the one that is left over?** (Let learners problem solve and provide a variety of suggestions like: **Throw it away/Give it to someone who does not have any crayons/Break it in half/etc.** It is important to not ignore the remainder. It must be acknowledged, so that learners get used to saying. **Five shared between 2 is 2 with one left over.**)
- Get learners to share **3** crayons and **7** crayons in their pairs.
- Discuss the sharing.

Activity 3: Learners work in groups

- Repeat Activity 1 and 2, but tell learners to share the crayons between the **4** learners in a group.
- Tell learners to share **8** crayons and **4** crayons, asking the questions from Activity 1.
- Tell learners to share **6** crayons and **10** crayons, asking the questions from Activity 2.

4. Classwork activity (25 minutes) (See next page)

5. Homework activity (5 minutes) (See next page)

6. Reflection on lesson



Term 1 Lesson 38: Sharing

Classwork

- Share these counters – make a drawing of what you do:
 - between two learners (○ ○) (○ ○)
 - between four learners (○) (○) (○) (○)
 - between two learners (○ ○) (○ ○) ○
 - between three learners (○) (○) (○) ○ ○
- There are 4 apples. Share the apples between Thabo and Ben.
How many apples will they each get? Draw a picture to show your working.
(○ ○) (○ ○) (2 apples each)
- There are 4 sweets. Share the sweets between Mary, Lebo and Thuli.
How many sweets will they each get? Draw a picture to show your working.
(○) (○) (○) (1 sweet each with one left over)
- There are 3 cars. Share the cars between Sipho and John.
How many cars will they each get? Draw a picture to show your working.
(○) (○) ○ (1 car each with one left over)

Homework

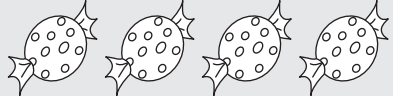
- Count the sweets.

-  (4)
-  (6)
-  (5)

- Share the sweets between two friends

- How many sweets does each friend get? (2 sweets)

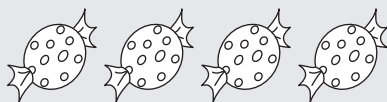

- How many sweets does each friend get? (3 sweets)



- How many sweets does each friend get? (2 sweets with one left over)



LESSON 39: PASSING TIME

Teacher's notes

CAPS topics: 1.1 Count objects, 1.16 Mental mathematics, 4.1 Time

Lesson vocabulary: Time, longer than, shorter than, faster than, slower than, yesterday, today, tomorrow, short time, long time

Prior knowledge:

Learners should have been taught how to:

- Talk about things that happened during the day and things that happened during the night.
- Sequence events that happened to them during the day.
- Order regular events from their own lives.

Concepts:

- Order regular events from own lives
- Compare lengths of time using language e.g. longer, shorter, faster, slower
- Sequence events using language such as **yesterday, today, tomorrow**

Resources: Box, stones, sequence pictures (e.g. the sequence of activities from waking up to getting to school), events pictures (e.g. eating breakfast and brushing teeth)

DBE workbook activities relevant to this lesson:

- DBE worksheet 16 (pp. 34 and 35)

Assessment: Refer to the tracker for today's formal/informal oral, practical or written assessment activity.

Remediation: Give the learners a set of pictures showing the routine from waking up in the morning to getting to school. Discuss these pictures with the learners. Ask them to put them in the correct sequence.

Enrichment: See enrichment activity cards – learners can use any cards from the back of this book.

1. Mental mathematics

1.1 Counting (5 minutes)

Introduce learners to numbers by using number rhymes, songs and games. For example:

One little, two little, three little monsters; four little, five little, six little monsters seven little, eight little, nine little monsters; ten of them can't scare me!

1.2 Recall and strategies (10 minutes)

Match the cards with the same number of objects. Order the cards. Example:

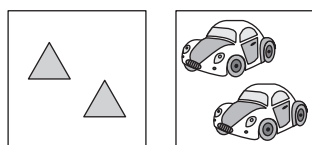

2. Correction/reflection on homework (15 minutes)

Reflection/remediation based on previous day's work/homework.

3. Lesson content – concept development (30 minutes)

In this lesson you introduce some vocabulary that is used in the topic of time. It is important that you use all of the different words – time words are abstract. You should also allow them the opportunity to say the words themselves. The activities that follow are planned to give learners the opportunity to experience intervals of time and to think about differences in timing/time taken for certain things to be done.

Activity 1: Whole class activity

- Ask: **What did you do yesterday after school?**
- Ask: **What will you do today after school?**
- Ask: **What will you do tomorrow after school?**
- Discuss the time it takes to do these things.

Activity 2: Whole class activity

- Take the learners outside to the school field.
- Learners stand in pairs next to each other and run a race.
- Ask each pair: **Who ran faster?**
- **Who ran slower?**
- **Who took a longer time?**
- **Who took a shorter time?**

Activity 3: Whole class activity

- Take the learners back into the class.
- Put up two pictures on the board, e.g. a child eating and a child brushing his/her teeth.
- Ask: **Does it take you longer to eat your breakfast or to brush your teeth?**
- Discuss other common activities with the class in relation to the time they take to get done.

Activity 4: Learners work in pairs – optional

- Ask learners to tell the person next to them about something they did yesterday, something they did today, and something they will do tomorrow.
- They should talk to each other about how long these things take to get done.

4. Classwork activity (25 minutes) (See next page)

5. Homework activity (5 minutes) (See next page)

6. Reflection on lesson

Term 1 Lesson 39: Passing time

Classwork

1. Draw a picture to show which takes a longer/shorter time.

	Compare	A longer time	A shorter time
a)	Walking to the shop <i>and</i> Driving to the shop	(Various drawings)	(Various drawings)
b)	Making a cup of tea <i>and</i> Making dinner	(Various drawings)	(Various drawings)
c)	Drawing one square <i>and</i> Drawing lots of squares	(Various drawings)	(Various drawings)

2. Draw a picture of something you take a long time to do.

(Various drawings)

3. Draw a picture of something you take a short time to do.

(Various drawings)

Homework

1. Draw something:

a) you did yesterday (Various drawings)

b) you did today (Various drawings)

c) you will do tomorrow. (Various drawings)

LESSON 40: TELLING TIME

Teacher's notes

CAPS topics: 1.16 Mental mathematics, 4.1 Time

Lesson vocabulary: Time, days of the week, months of the year, birthday, yesterday, today, tomorrow, morning, afternoon, night, early, late, longer, shorter, faster, slower

Prior knowledge:

Learners should have been taught how to:

- Talk about things that happen during the day and things that happen during the night.
- Sequence things that happen to them during the day.
- Order regular events from their own lives.

Concepts:

- Talk about the passing of time: compare lengths of time, sequence events, describe when something happens, identify the sequence of days of the week and months of the year, place birthdays on the calendar

Resources: Birthday chart (e.g. 12 coloured balloons), days of the week vocabulary cards, months of the year vocabulary cards

DBE workbook activities relevant to this lesson:

- DBE worksheet 32 (pp. 68 and 69)

Assessment: Refer to the tracker for today's formal/informal oral, practical or written assessment activity.

Remediation: In groups, learners practise a rhyme for the days of the week and months of the year. You make up your own rhymes.

Enrichment: See enrichment activity cards – learners can use any cards from the back of this book.

1. Mental mathematics

1.1 Counting (5 minutes)

Learners use a number board to count forwards and backwards in ones to a maximum of 20. Ask learners to start at different numbers and count on from there.

1.2 Recall and strategies (10 minutes)

Write numbers 1 up to 5 on the board. Ask: **Which is more: 2 or 3?** (3) **What can you tell me about 4 and 5?** (5 is more than 4/4 is less than 5) **Which is less: 3 or 2?** (2), etc.

2. Correction/reflection on homework (15 minutes)

Reflection/remediation based on previous day's work/homework.

3. Lesson content – concept development (30 minutes)

Activity 1: Whole class activity

- Stick the birthday chart balloons on the board.
- Ask learners when their birthdays are.
- Write or stick learners' names on the balloons.
- Ask: **What do you notice about the birthdays in our class?** (We have lots of birthdays in April/There are no birthdays in January/etc.)
- Use the birthday chart to guide you and ask questions like:
- **How many more birthdays are there in (November) compared to (June)?**
- **How many less birthdays are there in (February) than in (May)?**
- **Which month has the least birthdays?**
- **Which month has the most birthdays?, etc.**

Activity 2: Learners work in groups

- Ask learners to discuss the days of the week in their groups.
- Ask learners to identify an interesting event for each day (e.g. We tell our news on a Monday; We go to singing on a Tuesday; We have assembly on a Wednesday, etc.).

Activity 3: Learners work in groups

- Ask learners to discuss the months of the year in their groups.
- Ask learners to identify an interesting event for each month (e.g. My mom's birthday is in January/Valentine's day is in February/etc.)

4. Classwork activity (25 minutes) (See next page)

5. Homework activity (5 minutes) (See next page)

6. Reflection on lesson

Term 1 Lesson 40: Telling time

Classwork

1. Write the days of the week in order.

Wednesday Friday Saturday Monday
Sunday Tuesday Thursday

(Monday, Tuesday, Wednesday, Thursday, Friday, Saturday, Sunday)

(Some learners may suggest starting the week on Sunday)

2. Draw a picture of what you did on Sunday.

(Various drawings)

3. Write the months of the year in order.

March December July January May

September February October June

August April November

(January, February, March, April, May, June, July, August, September, October, November, December)

4. Draw a picture of something that happens in one of the months.

(Various drawings)

Homework

Use the words below to help you fill in the missing words. Draw a picture for each one. (Various drawings)

July January September December

- a) I start school in _____ (January).
b) It is cold in _____ (July).
c) Flowers start blooming in _____ (September).
d) It is very hot in _____ (December).