



**NATIONAL  
SENIOR CERTIFICATE**

**GRADE 11**

**NOVEMBER 2022**

**ELECTRICAL TECHNOLOGY:  
DIGITAL ELECTRONICS  
MARKING GUIDELINE  
(EXEMPLAR)**

**MARKS: 200**

---

This marking guideline consists of 13 pages.

---

**INSTRUCTIONS TO MARKERS**

1. All calculations with multiple answers imply that any relevant, acceptable answer should be considered.
2. Calculations
  - 2.1 All calculations must show the formulae.
  - 2.2 Substitution of values must be done correctly.
  - 2.3 All answers **MUST** contain the correct unit to be considered.
  - 2.4 Alternative methods must be considered, provided that the correct answer is obtained.
  - 2.5 Where an incorrect answer could be carried over to the next step, the first answer will be deemed incorrect. However, should the incorrect answer be carried over correctly, the marker has to re-calculate the values, using the incorrect answer from the first calculation. If correctly used, the candidate should receive the full marks for subsequent calculations.
  - 2.6 Markers should consider that learners answers may deviate slightly from the marking guideline depending on how and where in the calculation rounding off was used.
3. These marking guidelines are only a guide with model answers.
4. Alternative interpretations must be considered and marked on merit. However, this principle should be applied consistently throughout the marking session at ALL marking centres.

**QUESTION 1: MULTIPLE-CHOICE**

- 1.1 1.1 B ✓ (1)
  - 1.2 A ✓ (1)
  - 1.3 C ✓ (1)
  - 1.4 C ✓ (1)
  - 1.5 D ✓ (1)
  - 1.6 D ✓ (1)
  - 1.7 B ✓ (1)
  - 1.8 A ✓ (1)
  - 1.9 A ✓ (1)
  - 1.10 D ✓ (1)
  - 1.11 A ✓ (1)
  - 1.12 C ✓ (1)
  - 1.13 D ✓ (1)
  - 1.14 B ✓ (1)
  - 1.15 C ✓ (1)
- [15]**

**QUESTION 2: OCCUPATIONAL HEALTH AND SAFETY**

- 2.1 2.1.1
    - Seating position ✓
    - Standing position
    - Regular movement
    - Organisation of work (Any 1 x 1) (1)
  - 2.1.2
    - Temperature ✓
    - Lighting
    - Reflection and glare
    - Humidity
    - Noise
    - Space (Any 1 x 1) (1)
  - 2.2 Inadequate lighting leads to decreased visibility and movement ✓ which could lead to injury to yourself or others. ✓ (2)
  - 2.3 It protects the worker ✓ from unnecessary or avoidable hazards. ✓ (2)
  - 2.4 They are warning signs ✓ that make people aware of potential hazards in an area. ✓ (2)
  - 2.5 Regulations are necessary to control the conditions under which work is done ✓ in order to protect everyone in the workplace. ✓ (2)
- [10]**

**QUESTION 3: TOOLS AND MEASURING INSTRUMENTS**

- 3.1
- Clean regularly to remove any build-up of dust or dirt. ✓
  - Check that connecting leads are in good working order. ✓
  - Store safely in a dry place when not in use. ✓
- (3)

3.2 3.2.1  $V_{\max} = V/\text{div} \times \text{no. of divisions} \checkmark$   
 $= 5 \times 3 \checkmark$   
 $= 15 \text{ V} \checkmark$

(3)

3.2.2  $T = T/\text{div} \times \text{no. of divisions}$   
 $= 2 \times 10^{-3} \times 5 \checkmark$   
 $= 10 \times 10^{-3} \text{ s} = 10 \text{ ms} \checkmark$   
 $f = \frac{1}{T}$   
 $= \frac{1}{10 \times 10^{-3}} \checkmark$   
 $= 100 \text{ Hz} \checkmark$

(4)

**[10]****QUESTION 4: LOGICS**

4.1

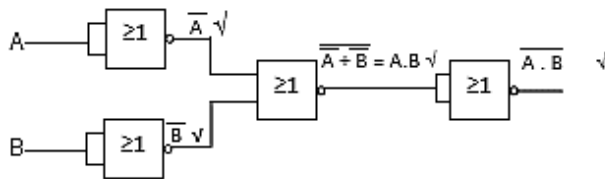

✓ Drawing correct (4)

4.2 4.2.1

A	B	X	
0	0	0	✓
0	1	1	✓
1	0	1	✓
1	1	1	✓

(4)

4.2.2  $X = \bar{A}.B \checkmark + A.\bar{B} \checkmark + A.B \checkmark$

(3)

4.2.3  $\bar{A}B + A\bar{B} + AB = B(A + \bar{A}) + A\bar{B} \checkmark$   
 $= B + A\bar{B} \checkmark$   
 $= A + B \checkmark$

(2)

4.2.4

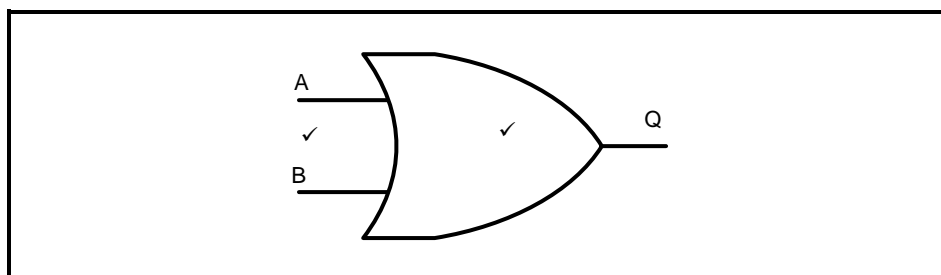

(2)

4.3  $\bar{A}.B.\bar{C} + \bar{A}.B.C + \bar{A}.\bar{B}.C = \bar{A}(B.\bar{C}) \checkmark + \bar{A}(B.C) \checkmark + \bar{A}(\bar{B}.C) \checkmark$   
 $= \bar{A}(B + C) \checkmark$   
 $= \bar{A}B + \bar{A}C \checkmark$  (5)

4.4 The Product of Sum notation is where the Boolean expression is made up of a number of sum terms, separated by a product sign.  $\checkmark$   
 $Q = (A + B).(A + C).(B + C) \checkmark$   
 The Sum of Product notation is where the Boolean expression is made up of a number of product terms, separated by a sum sign.  $\checkmark$   
 $Q = A.B + A.C + B.C \checkmark$  (4)

4.5 4.5.1  $Q = \overline{AB + \bar{B}C + C\bar{D}} \checkmark$   
 $Q = \overline{\overline{AB}.\overline{\bar{B}C}.\overline{C\bar{D}}} \checkmark$  (2)

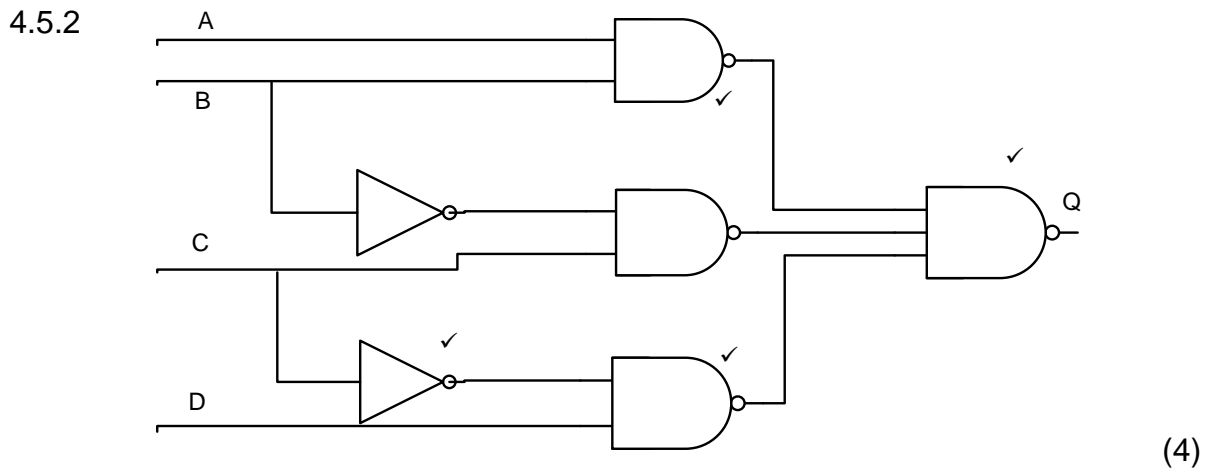

4.6

$\checkmark$	$AB$	$A\bar{B}$	$\bar{A}B$	$\bar{A}\bar{B}$
$C$	0	0	0	1 $\checkmark$
$\bar{C}$	1 $\checkmark$	1 $\checkmark$	1 $\checkmark$	0

$Q = A \checkmark$  (7)

4.7

INPUTS		OUTPUTS	
A	B	SUM $\checkmark$	CARRY $\checkmark$
0	0	0	0 $\checkmark$
0	1	1	0 $\checkmark$
1	0	1	0 $\checkmark$
1	1	0	1 $\checkmark$

(6)

- 4.8
- Logic High ✓
  - Logic Low ✓
  - Pulses ✓
  - Line tri-stated ✓
- (4)
- 4.9 Break the line extending across the variables ✓ and change the sign ✓ that connected those two variables under the original line. ✓
- (3)

**[50]****QUESTION 5: WAVEFORMS**

- 5.1
- Magnetic field ✓
  - Electric field ✓
- (2)

5.2

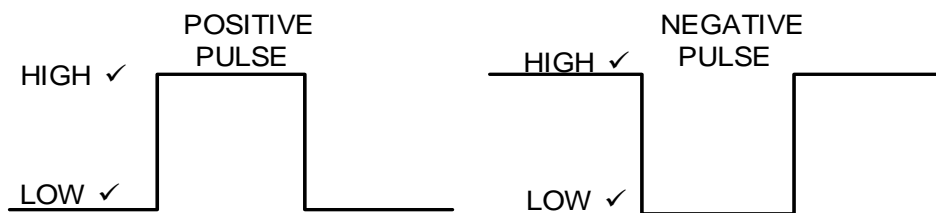

(4)

- 5.3
- 5.3.1 The time it takes for a pulse to change from a low state to a high state. ✓ It is measured between the 10% and 90% points of the completed pulse. ✓
- (2)
- 5.3.2 The relationship between the high time ✓ and the low time ✓ of a pulse.
- (2)
- 5.3.3 The continuous train ✓ of regular square wave pulses. ✓
- (2)

5.4 5.4.1

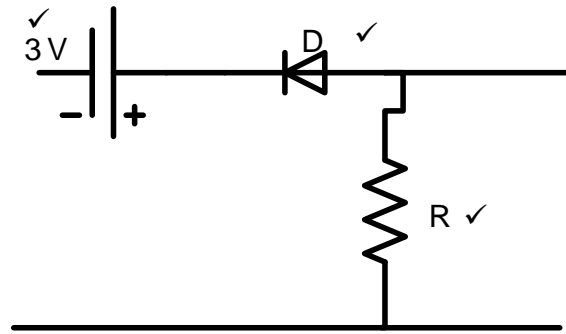

Circuit correct ✓

(4)

5.4.2

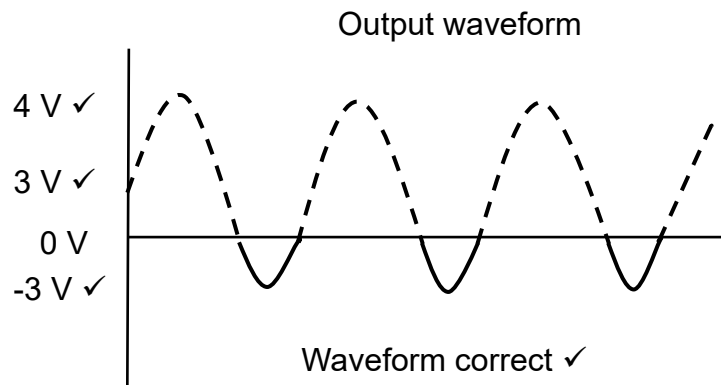

(4)

$$\begin{aligned}
 5.5 \quad V_{peak} &= \frac{V_{RMS}}{0,707} \text{ V } \checkmark \\
 &= \frac{12,8}{0,707} \checkmark \\
 &= 18,1 \text{ V } \checkmark
 \end{aligned}$$

(3)

$$\begin{aligned}
 5.6 \quad T &= \frac{1}{f} \text{ sec } \checkmark \\
 &= \frac{1}{2750} \checkmark \\
 &= 0,36 \text{ msec } \checkmark
 \end{aligned}$$

(3)

$$\begin{aligned}
 5.7 \quad \text{Form factor} &= \frac{RMS}{AVE} \checkmark \\
 &= \frac{12,8 \times 0,707}{12,8 \times 0,636} \checkmark \checkmark \\
 &= 1,11 \checkmark
 \end{aligned}$$

(4)

[30]

**QUESTION 6: RLC CIRCUITS**

6.1 The current leads the voltage. ✓ (1)

6.2 The inductive reactance will increase. ✓ (1)

6.3

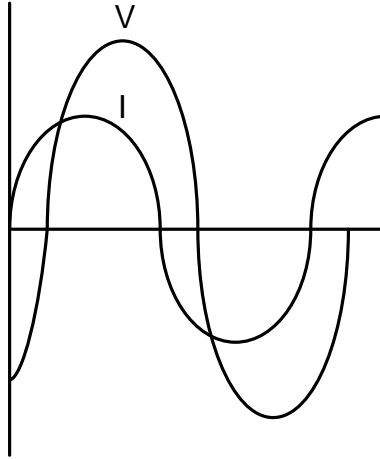

Shape of voltage waveform larger than current waveform. ✓  
Phase difference showing current leading voltage ✓

(2)

6.4 It is the ratio ✓ of the real power to the apparent power in a circuit. ✓ (2)

6.5 The increase in frequency will cause a decrease in the capacitive reactance. ✓ This will cause a decrease in the impedance of the RC circuit, ✓ which will cause the current to increase. ✓ (3)

6.6  $\cos \theta = \frac{P}{S}$   
 $P = S \cos \theta$  ✓  
 $= 5 \times 0,75$  ✓  
 $= 3,75 \text{ W}$  ✓ (3)

6.7 6.7.1  $X_C = \frac{1}{2\pi fC}$  ✓  
 $= \frac{1}{2 \times \pi \times 100 \times 75 \times 10^{-6}}$  ✓  
 $= 21,22 \Omega$  ✓ (3)

6.7.2  $Z = \sqrt{R^2 + (X_L - X_C)^2}$  ✓  
 $= \sqrt{22^2 + (31,43 - 21,22)^2}$  ✓  
 $= 24,25 \Omega$  ✓ (3)

6.7.3  $I = \frac{V}{Z}$  ✓  
 $= \frac{110}{24,25}$  ✓  
 $= 4,54 \text{ A}$  ✓ (3)



$$\begin{aligned} 6.7.4 \quad S &= VI \checkmark \\ &= 110 \times 4,54 \checkmark \\ &= 498,97 \text{ VA} \checkmark \end{aligned} \tag{3}$$

$$\begin{aligned} 6.7.5 \quad X_L &= 2\pi fL \\ L &= \frac{X_L}{2\pi f} \checkmark \\ &= \frac{31,43}{2 \times \pi \times 100} \checkmark \\ &= 0,05 \text{ H} = 50 \text{ mH} \checkmark \end{aligned} \tag{3}$$

$$\begin{aligned} 6.7.6 \quad \cos \theta &= \frac{P}{S} \checkmark \\ &= \frac{400}{498,97} \checkmark \\ &= 0,8 \checkmark \end{aligned} \tag{3}$$

**[30]**

**QUESTION 7: SEMICONDUCTOR DEVICES**

7.1 When P-type and N-type materials are joined, holes of the P-type and electrons of the N-type combine to form covalent bonds. ✓ The electrons diffuse and occupy the holes in the P-type material. A small region of the N-type near the junction loses electrons and behaves like intrinsic semiconductor material. ✓ In the P-type, a small region get filled up by holes and behaves like an intrinsic semiconductor material. ✓ This thin intrinsic region is called the depletion region, since it is depleted of charge and offers high resistance. ✓ (4)

7.2 In simple voltage regulators. ✓ (1)

7.3 '+' on anode, '-' on cathode ✓

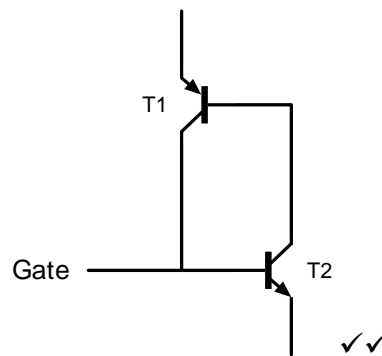

'+' pulse on the gate switches TR2 on causing collector of TR2 to become more negative. ✓

This switches TR1 on, its collector going positive which keeps TR2 on even though the '+' pulse on gate has been removed. ✓

Current will continue to flow until either the supply is removed between the anode and cathode, or the current falls below the holding current. ✓ (6)

7.4 The Q-point on the load line is the point at which DC bias is provided to the transistor ✓ to ensure that it operates, ✓ depending upon the class of the transistor amplifier. ✓ (3)

7.5

- Diode must be removed from the circuit before testing. ✓
- Diode should be tested in both directions and it should only give a reading in one direction and it is acceptable. ✓ (2)

7.6

- Cut-off ✓
- Active ✓
- Saturation ✓ (3)

7.7

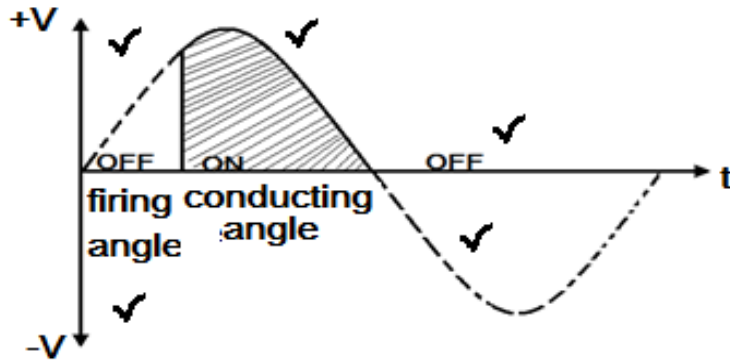

(5)

7.8

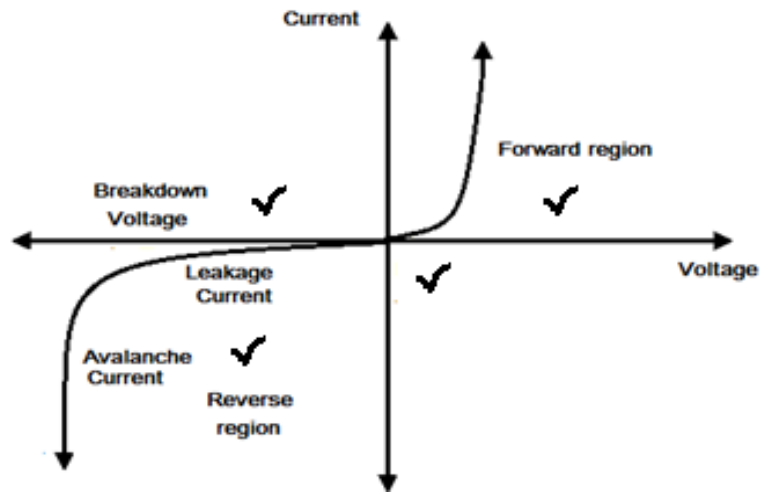

(4)

7.9

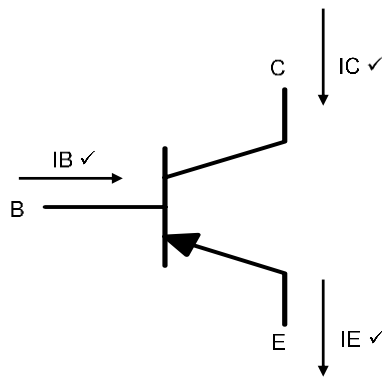

(4)

7.10 7.10.1

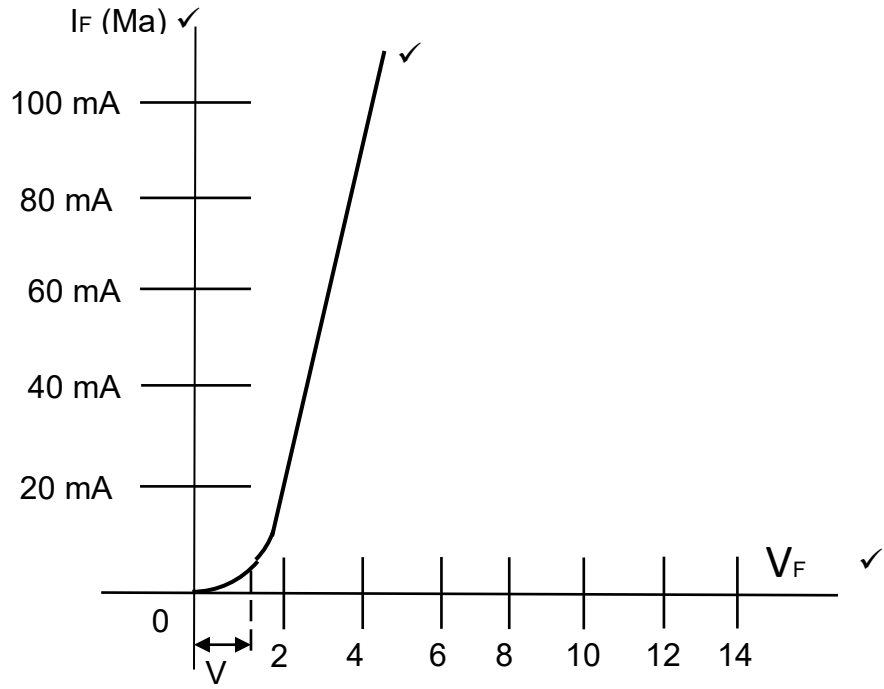

(3)

7.10.2

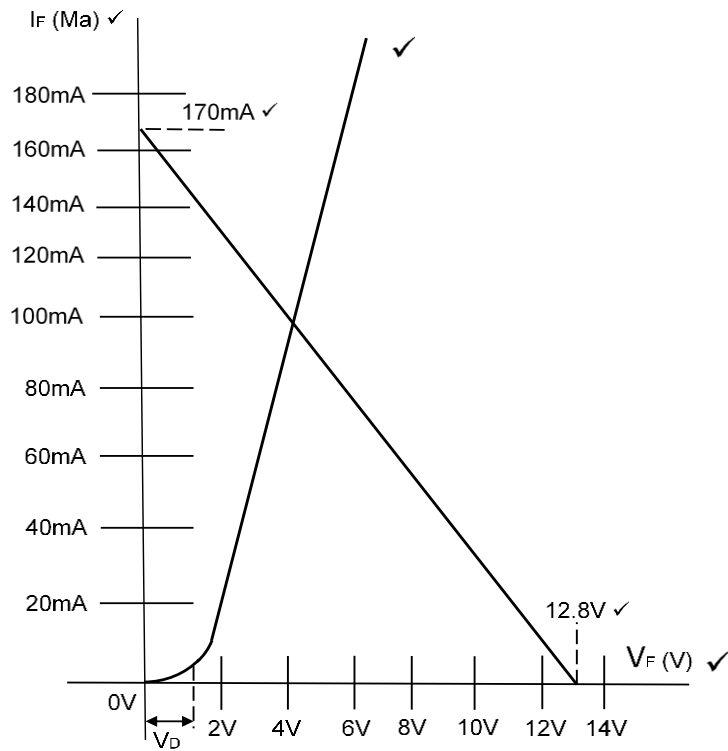

(5)  
[40]

**QUESTION 8: SENSORS AND TRANSDUCERS**

8.1 The ability of certain crystal materials to generate an electric charge ✓ across the opposite faces when the material is subjected to mechanical stress. ✓ (2)

8.2 A sensor is a device that detect or senses ✓ and reacts to and measure physical quantities ✓ while a transducers changes energy ✓ from one form to another. ✓ (4)

8.3 The brighter the light on the surface, the lower the resistance. ✓ The darker the light on the surface, the higher the resistance. ✓ (2)

8.4 This device interconnects two electrical circuits ✓ transferring electrical signals via light. ✓ (2)

8.5

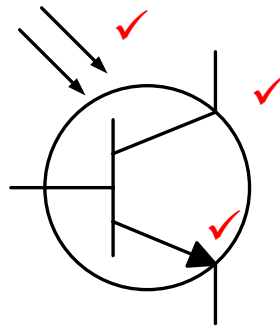

(3)

8.6 Negative Temperature Coefficient will have a decrease in electrical resistance, ✓ as the temperature of the device increases. ✓ (2)

**[15]**

**TOTAL: 200**