



## TOM NEWBY SCHOOL EXAMINATION



<b>Subject</b>	<b>MATHEMATICS</b>	<b>Examiner/s</b>	<b>MISS KLEMP/ MR PHILLIPS/ MRS FOURIE</b>
<b>Date</b>	<b>5 June 2018</b>	<b>Total marks</b>	<b>100</b>
<b>Duration</b>	<b>2 HOURS</b>		
<b>Grade</b>	<b>7</b>	<b>Moderator</b>	<b>MRS FOURIE</b>
<b>Special instructions/ Equipment</b>	<ol style="list-style-type: none"> <li>1. Write your name, surname and class on the question paper and answer sheet.</li> <li>2. Read through each question carefully and follow the instructions.</li> <li>3. <b>NO</b> calculators.</li> <li>4. Check the mark allocation for each question.</li> <li>5. You will need to use your protractor, pencil, pen and ruler.</li> <li>6. <b>GOOD LUCK</b></li> </ol>		
<p>This assessment has been compiled using notes and information contained in the Tom Newby School resource material. The marking memorandum has been compiled accordingly. While alternative responses will be given due acknowledgement, the official memorandum will be considered a priority document to ensure uniformity of marking.</p>			

<b>Name:</b>	<b>Surname:</b>	<b>Class:</b>
--------------	-----------------	---------------

### **QUESTION 1 – Multiple Choice**

**[13]**

Write the correct letter next to the corresponding number.

1. If the distance between two lines never change, they are:

- |                       |             |     |
|-----------------------|-------------|-----|
| a) Perpendicular      | b) Parallel |     |
| c) Intersecting lines | d) Rays     | (1) |

2. An isosceles triangle has:

- |                      |                   |     |
|----------------------|-------------------|-----|
| a) Three equal sides | c) No equal sides |     |
| b) Two equal sides   | d) Not a, b or c  | (1) |

3. 9 347 879 rounded off to the nearest 1 000 is?

- |              |              |     |
|--------------|--------------|-----|
| a) 9 348 000 | c) 9 348 300 |     |
| b) 9 347 380 | d) 9 350 000 | (1) |



**QUESTION 2**

**[13]**

Write down the answers only.

1. What value does the digit 6 have in 329,765?

\_\_\_\_\_

(1)

2. Simplify  $\frac{21}{56}$  \_\_\_\_\_

(1)

3. Use the shape below to answer the questions that follow:

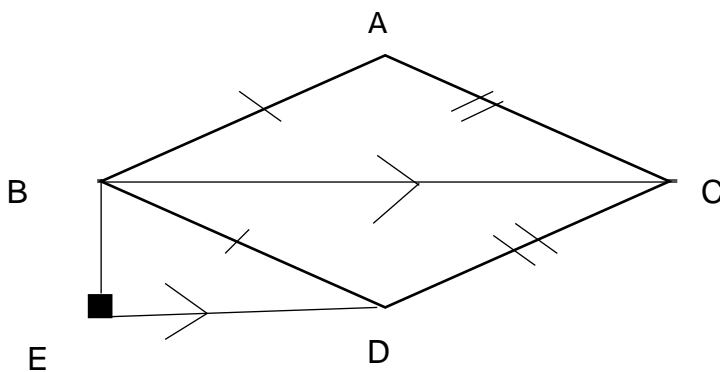

Complete by naming a line:

- a)  $AB \perp$  \_\_\_\_\_

(1)

- b)  $BC \parallel$  \_\_\_\_\_

(1)

- c)  $BE \perp$  \_\_\_\_\_

(1)

4. List the composite numbers smaller than 20 that are multiples of 3. (2)

\_\_\_\_\_

5. What is 25% of 3 hours and 20 minutes? (2)

\_\_\_\_\_

\_\_\_\_\_

6. Use your protractor to measure the size of:

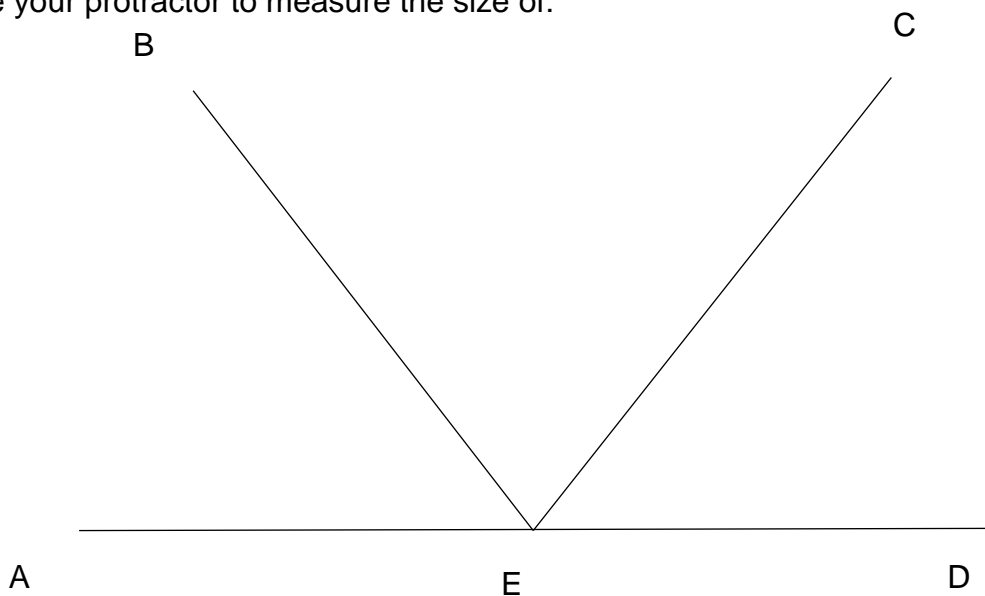

a) Angle AEB \_\_\_\_\_ (1)

b) Angle BED \_\_\_\_\_ (1)

6. Fill in < ; > or =

a)  $\frac{4}{7}$    $\frac{3}{4}$  \_\_\_\_\_ (1)

b)  $\sqrt{121}$    $\sqrt[3]{1000}$  \_\_\_\_\_ (1)

### QUESTION 3

[17]

1. Write 1 650 as the product of its prime factors. (3)

(Use the ladder method)

\_\_\_\_\_

2. Fill in the missing numbers in the sequence:

$\frac{1}{3}$ ; \_\_\_\_\_; 3; 9; \_\_\_\_\_ (2)

3. Simplify the following ratio

24: 36: 60 (1)

4.  $\frac{4}{5} \times 3\frac{1}{3}$

(3)

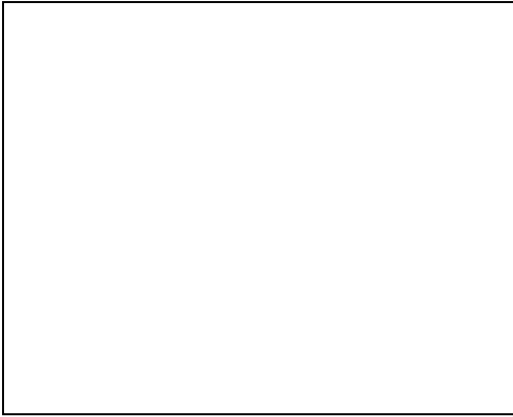

5.  $324,34 + 17,807 - 78,528$

(2)

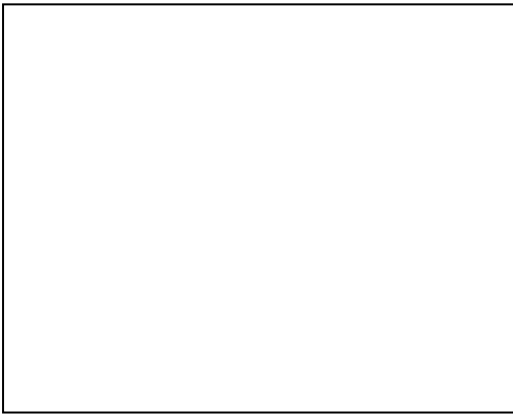

6.  $0,072 \div 12$

(1)



7. 108 Grade 7 learners watched a Soccer match. The ratio of boys to girls was 7:2.  
How many girls watched the match? (3)



8. A bank gives 7% interest a year. If I put R2 500 in a bank account, what amount will there be in the account after 1 year? (2)

**QUESTION 4****[18]**

1. Complete the table below:

	Simplified fraction	Decimal	Percentage
36 minutes of 3 hours	a	b	c
75cm of 5m	d	e	f

(6)

2. Calculate the following and write the answer in its simplest form:

a)  $4\frac{1}{4} + 1\frac{2}{3} - 2\frac{1}{6}$  (3)

b)  $2\frac{1}{4} \div 1\frac{2}{3}$  (3)

3. A company is planning a dinner for 125 people. The food is expected to cost R85 per person, and the drinks R39 per person. The cost of hiring the venue for the evening is R1 950. Calculate the total cost, for the company to host the dinner. Then calculate the cost per person. (Round off to the nearest Rand). **(6)**

**QUESTION 5****[19]**

1. Soccer balls cost R138,00 each. Joe wants to buy one, but he has only saved R98,55 so far. The shop is prepared to give him a 15% discount.
- a) Calculate how much the discounted price will be.

---



---



---



---

- b) Does Joe have enough money? If not, how much does he still need? (4)

---



---



---

2. Use the shape below, to answer the questions that follow:

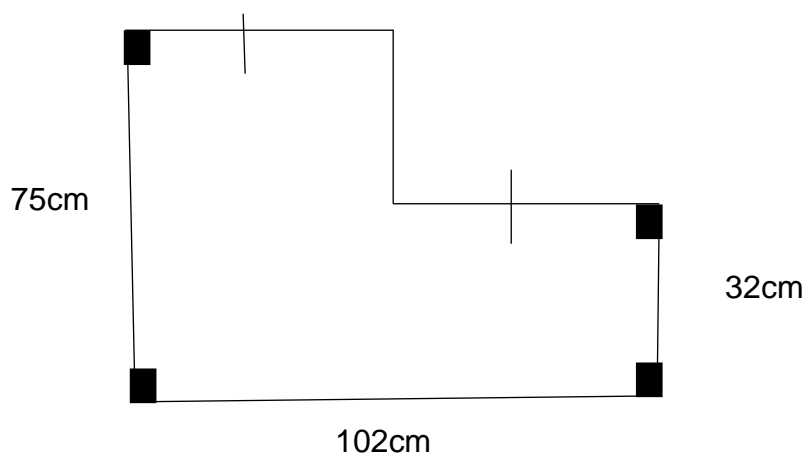

- a) Calculate the perimeter of the shape. (2)

---

---

---

- b) Convert the perimeter into meters. (1)

---

- c) Calculate the area of the shape. (3)

---

---

---

3. Calculate the volume of the prisms:

a)

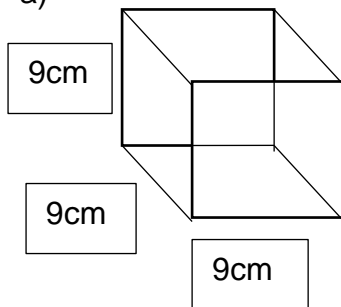

b)

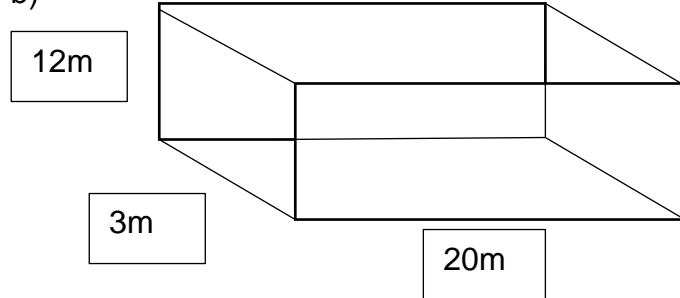

c)

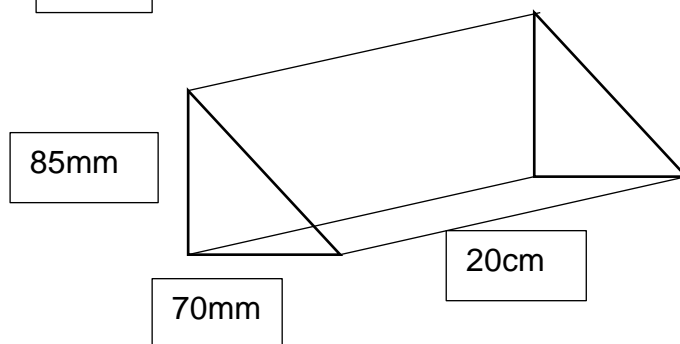



a)	b)	c)
----	----	----

(3 x 3 = 9)

**QUESTION 6 – (Show ALL calculations.)**

**[20]**

1. What number must be added to 23 489 to get 32 530?

(2)

---

---

---

2. What number exceeds 72 409 by 27 326?

(2)

---

---

---

3.  $20^2 - (\sqrt[3]{125} \times 62)$

(3)

---

---

---

---

4. Use your protractor and ruler:

a) Construct  $\triangle ABC$  with  $AB = 80\text{mm}$ ;  $\text{Angle } ABC = 50^\circ$  and  $BC = 65\text{mm}$ .

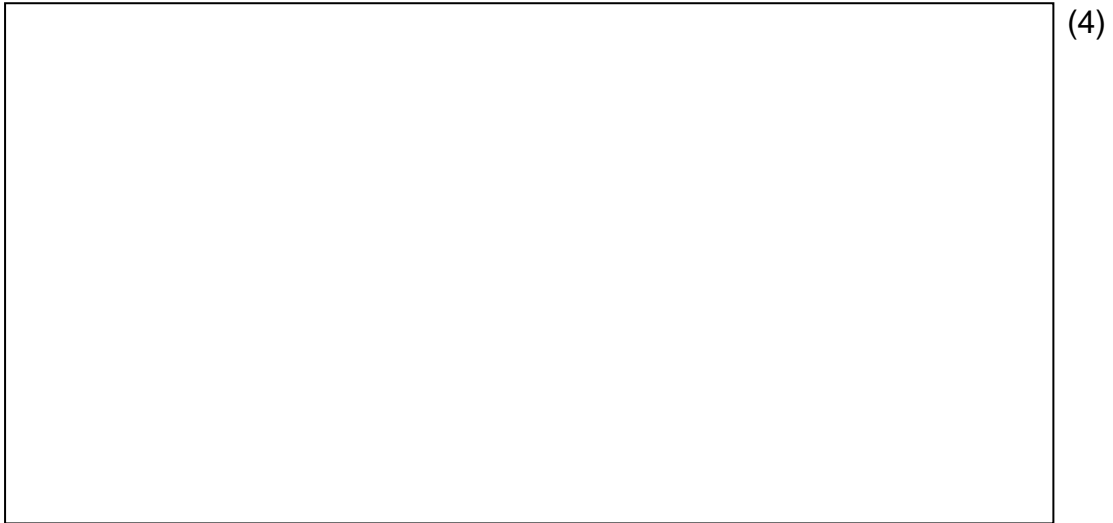

b) Measure angle ACB \_\_\_\_\_ (1)

5. Calculate the answer. Show ALL working out.

$2,79 \times 7,5$  (3)



6. Romy competed in a cross country race of 15km. She completed only  $\frac{2}{5}$  of the race.

What distance did Romy run? (1)

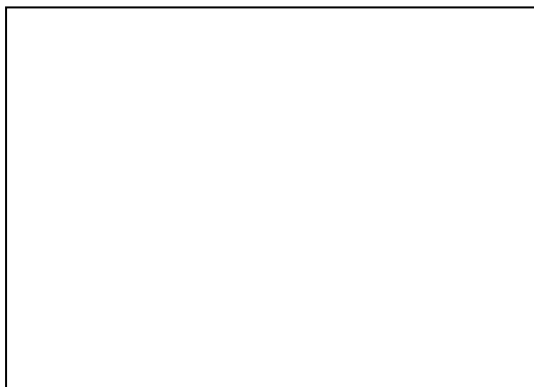

7. To open a coke bottle you have to turn the top 3 full turns.

- a) Through how many degrees do you have to turn the top in order to open the bottle? (2)



- b) What fraction would  $270^\circ$  be of the total number of degrees the top has to rotate in order to open the bottle? (2)



**Total: 100**